

PUBLICATION UPDATE BULLETIN

DATE: 03/16/84

This PUB:

Class Code: 4103

Base Documents: 729-0602-A and 729-0935-A

Previous Notice(s):None

This Publication Update Bulletin (PUB) documents the phase-lock-loop (PLL) adjustment procedure for the 210-8694/8794 board in the 2200LVP/SVP Disk Processing Unit (DPU). The adjustment procedure in this PUB supercedes the one in Section 11.3 of the Model 2200LVP Product Maintenance Manual (729-0602-A). This PUB also serves as an addendum to the 2200SVP Product Maintenance Manual (729-0935-A).

WANG

LABORATORIES, INC

ONE INDUSTRIAL AVENUE, LOWELL, MASSACHUSETTS 01851, TEL (617) 459-5000, TWX 710 343-6769, TELEX 94-7421

PRINTED IN U.S.A.

A. REQUIRED TOOLS/TEST EQUIPMENT

- PLL Adjustment Utility Program diskette (732-0009B)
- Oscilloscope
- DVM
- Small slot screwdriver
- Short length of jumper wire
- Operating System diskette
- One DSDD work diskette
- Two DSDD diskettes that were formatted in two different units other than the unit under test)

B. INITIAL DIAGNOSIS

This PLL adjustment procedure is presented in three parts. The CE must first determine the extent of the adjustment required and then perform the recommended procedure(s) as follows:

Adjustment Procedures 1, 2 and 3 must be performed to correct a major problem such as a Winchester disk drive completely out of adjustment, or lack of communication between the Disk Processing Unit (DPU) and either or both drives.

Adjustment Procedure 2 is used to "fine tune" the DPU in cases where communication does exist between the DPU and its drives; however, random errors may occur from time to time.

Adjustment Procedure 3 is the Verify Winchester While Suppressing Retries Test and the Alternate Sectors Test. These tests are presented to aid the CE in diagnosing problems associated with the Winchester disk drive itself.

CAUTIONS

1. Be certain the "reference" diskettes are error free. Whenever possible, use fresh diskettes from stock - do not use diskettes formatted in the field.
2. Diskette 732-0009B and Operating System 2.5 (or greater) will have a pre-written worst-case pattern on the inner two tracks for use in floppy drive adjustments. Do not write on these tracks.
3. Switch ac power OFF prior to removing/inserting any logic board from/into the unit.
4. The Operating System does not have to be loaded in to perform any of the steps given in Adjustment Procedure 1.
5. All references to test points, IC pins, potentiometers, etc. pertain to the 210-8694 board (see figure 1).
6. Wires inserted into plate-through holes are available on the noncomponent side of the board to connect the oscilloscope probe to when performing steps 7 and 8 of Adjustment Procedure 1.

C. ADJUSTMENT PROCEDURE 1 (Coarse Adjustment)

1. Using a jumper wire, connect TP1 (Test Point #1) to +0V (GND).
2. Set the DVM (or oscilloscope) controls to measure +4.00V dc.
3. Connect the DVM (or oscilloscope) ground probe to +0V (GND).
4. Connect the DVM (or oscilloscope) signal probe to L5 pin 1 or 2.
5. Adjust potentiometer R16 for a +4.00V dc indication.
6. Carefully remove the jumper wire from TP1.
7. Connect both oscilloscope probe ground leads to +0V (GND).
8. Connect oscilloscope Channel 1 (or A) probe to L8 pin 11 (phase detector reference clock).
9. Connect oscilloscope Channel 2 (or B) probe to L4 pin 6 (voltage controlled oscillator-VCO-output).

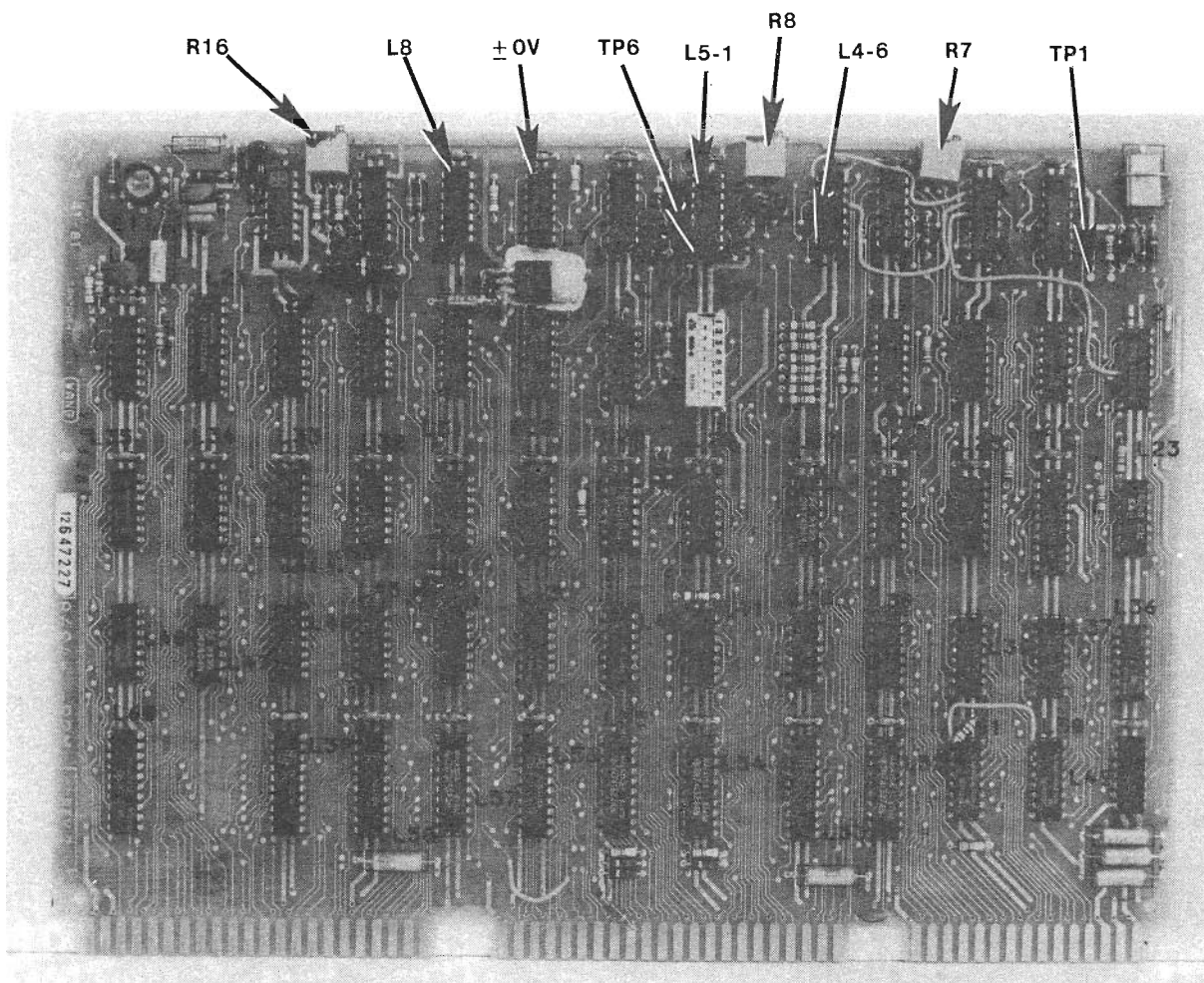

B-01311-FY84-1

FIGURE 1 WL NO. 210-8694 TEST POINTS AND POTENTIOMETERS

10. Set the oscilloscope controls as follows.

Display Mode: Alternate
Trigger source: Channel 1 (or A)
Trigger Mode: Normal (dc coupling)
Trigger Slope: Positive
Time Base: 0.1 usec/div
Vertical Sensitivity: 2V/div
Input Coupling: dc

11. Adjust potentiometer R7 (Winchester drive adjustment) as follows:

CAUTION

The shaft of potentiometer R7 may be secured tight with Glyptol. Do not try to remove the Glyptol; instead gently rotate the shaft of R7 back and forth to loosen it.

- a. Turn R7 completely counterclockwise (as evidenced by the indent "click" heard once during each rotation of R7 when it is at that stop).

NOTE

It may require as many as 20 turns of R7 to reach the indent.

- b. Turn R7 slowly clockwise until the VCO output signal (Channel 2 or Channel B) is stable--not free running.
- c. Continue adjusting R7 clockwise until all the VCO output pulses are centered with respect to the phase detector reference clock pulses (see figure 2). When this condition occurs, the PLL is "locked". When the output pulses are centered, the VCO output pulse period will be approximately 0.115 usec (figure 2).

NOTE

Figure 3 shows an incorrect VCO output signal. Note that the higher frequency of the VCO output in the figure results in an extra pulse (ten instead of nine) in the VCO output.

- d. If necessary, repeat step 11 several times to ensure proper adjustment.

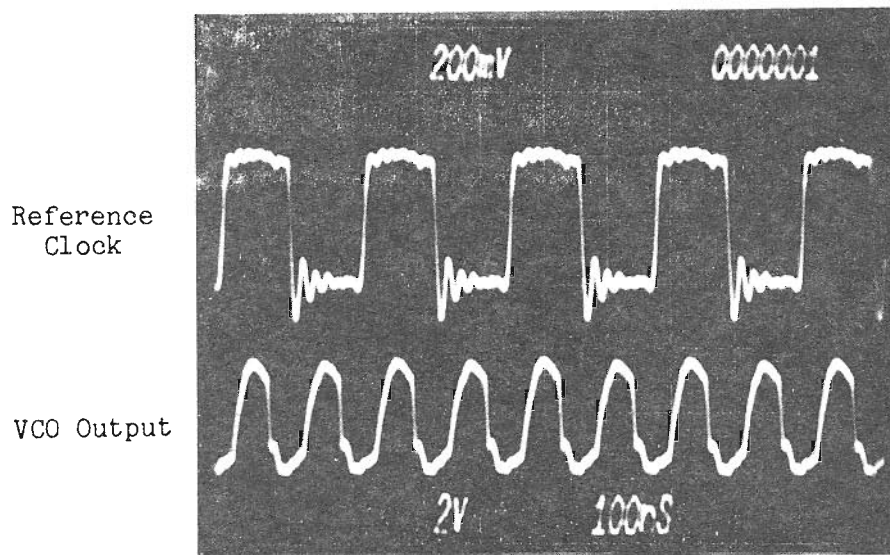

FIGURE 2 PLL CORRECTLY ADJUSTED FOR WINCHESTER DISK DRIVE

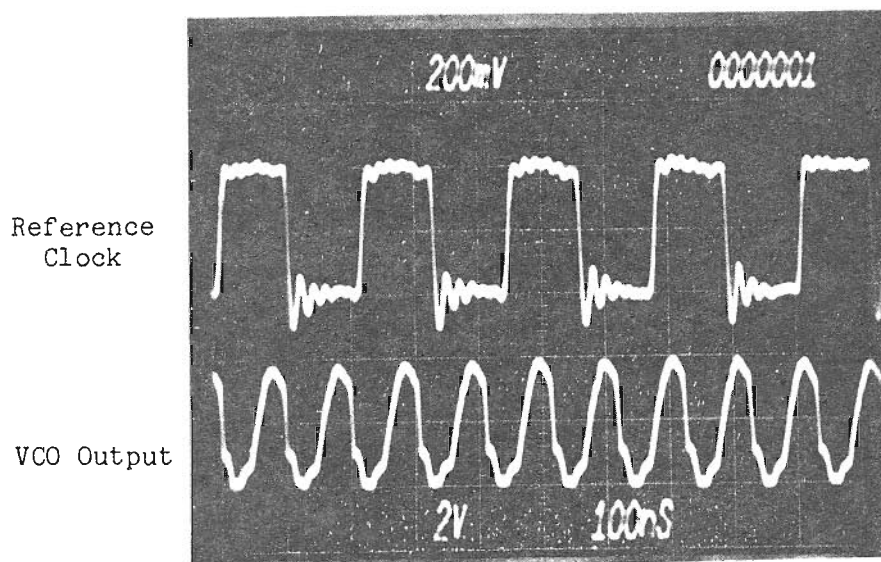

FIGURE 3 PLL INCORRECTLY ADJUSTED FOR WINCHESTER DISK DRIVE

12. Verify that the adjustment is correct by connecting a jumper from TP6 to +0V (GND) and then removing the wire. This momentarily selects the diskette drive frequency. The PLL should "lock back up" on the Winchester disk drive frequency (figure 2) when the jumper is removed as indicated by the VCO output automatically returning to a stable, not free-running state. If the PLL does not "lock up" (figure 4), continue adjusting R7 in the clockwise direction until the conditions in step 11 are met and the PLL "locks up".

NOTE

If Necessary, repeat step 12 several times to ensure proper adjustment.

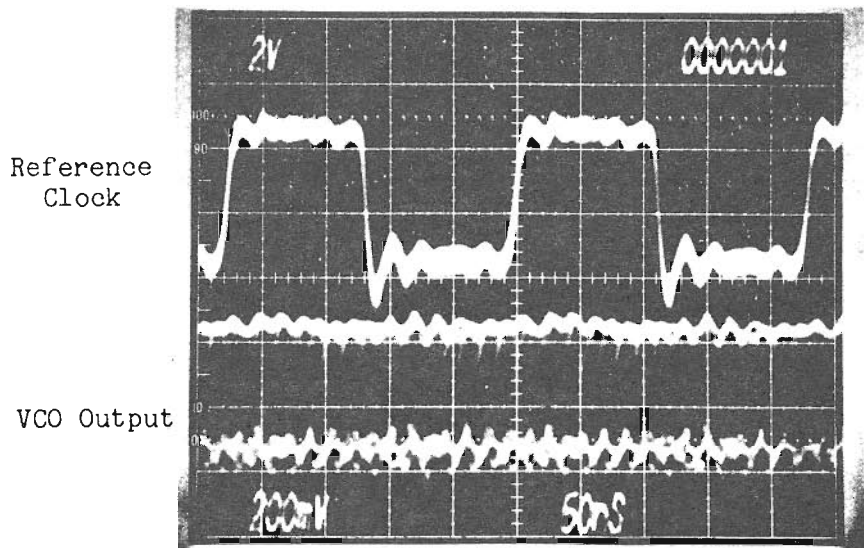

FIGURE 4 PLL NOT "LOCKED"

13. Again verify that the adjustment is correct by setting the CPU ac power switch OFF and then back ON. After setting the power ON, note the actions of the actuator damper on the Winchester disk drive. (The damper is a 3-inch cylinder mounted on the narrow side of the drive and distinguished by a yellow CAUTION sticker). The actuator should restore the heads to track 0 and then position the heads at the last track. If any retries occur, that is a restore operation and re-seek to the last track, continue adjusting R7 in the clockwise direction until the conditions in steps 11 and 12 are met and no retries occur as stated above.
14. Select the diskette drive frequency by connecting a jumper between TP6 and +0V (GND).
15. Slowly adjust potentiometer R8 (diskette drive adjustment) until the leading edge of the VCO output pulse (Channel 2) occurs 0.075 usec after the leading edge of the phase detector reference clock as shown in figure 5. Figures 6 and 7 show incorrect VCO output signals.
16. Carefully remove all jumpers. Power the system down.

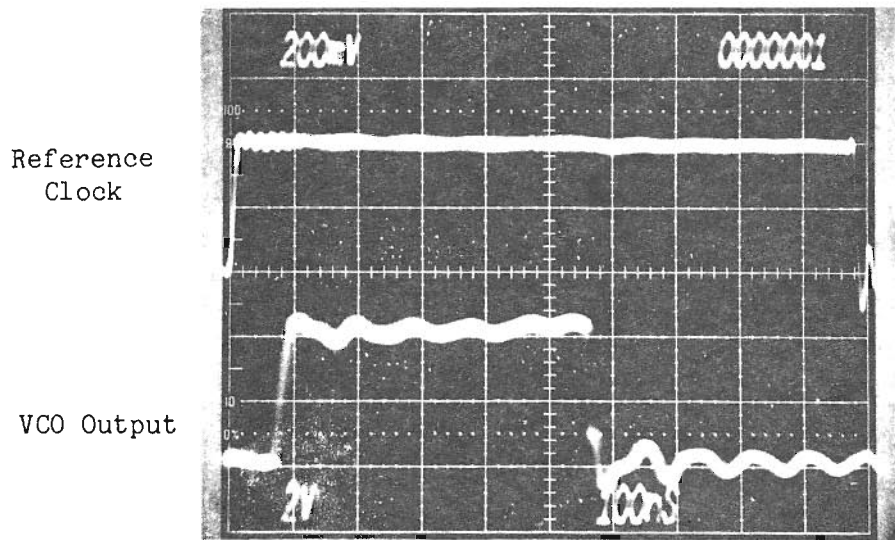

FIGURE 5 PLL CORRECTLY ADJUSTED FOR DISKETTE DRIVE

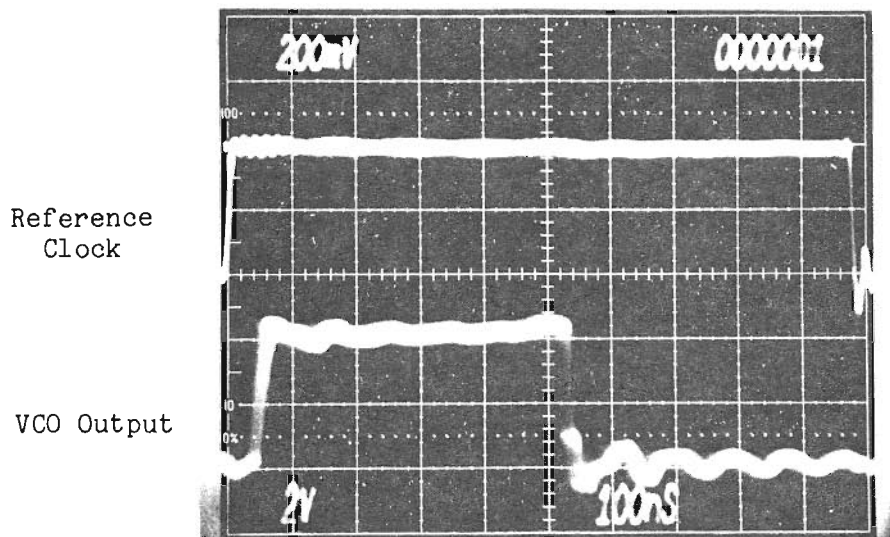

FIGURE 6 PLL INCORRECTLY ADJUSTED FOR DISKETTE DRIVE

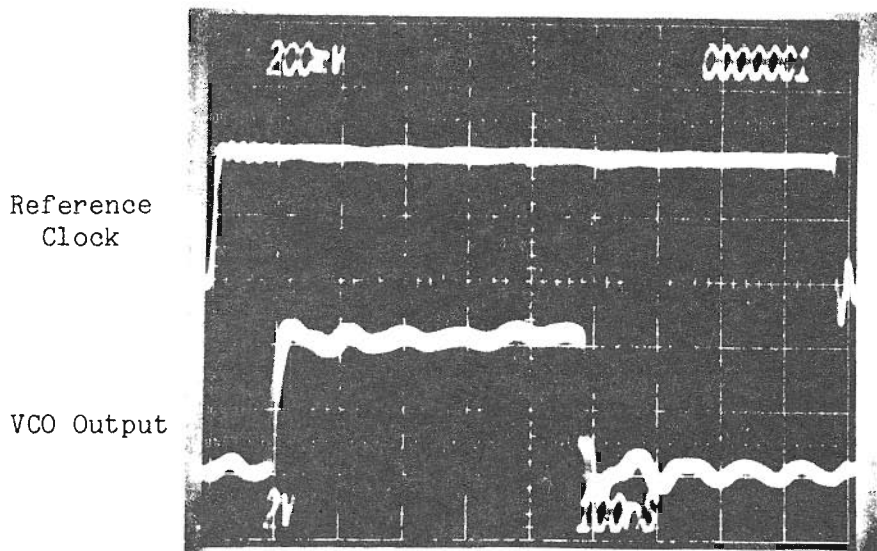

FIGURE 7 PLL INCORRECTLY ADJUSTED FOR DISKETTE DRIVE

D. ADJUSTMENT PROCEDURE 2 ("Fine Tuning")

1. Power the system down for approximately 30 seconds and then power it back up.
2. Insert an Operating System (OS) diskette into the DSDD drive, load the OS, and then remove the diskette.

CAUTION:

BEFORE CONTINUING WITH THE "FINE TUNING" ADJUSTMENT PROCEDURE, BACKUP ALL CUSTOMER DATA RESIDING ON THE WINCHESTER DISK DRIVE.

3. Insert a PLL adjustment utility program diskette 732-0009A (or B) into the DSDD drive.
4. Enter the following routine on the workstation keyboard to load and run the utility program. If running Utility 732-0009A, remove the diskette from the drive. If running Utility 732-0009B, leave the diskette in the drive. Observe the display shown at the top of the next page.

```

SELECT DISK B10
(RETURN)
LOAD RUN
(RETURN)

```

LVP PHASE LOCK LOOP PROGRAM

KEY SF' 16 TO RETURN TO MENU

SF'0 - FORMAT PLATTERS
 SF'1 - ADJUST FLOPPY
 SF'2 - ADJUST WINCHESTER
 SF'3 - WRITE FLOPPY INNER TRACKS WITH HEX (0B6DB6)
 SF'4 - WRITE FLOPPY INNER TRACKS WITH HEX (015AA5)
 SF'5 - WRITE FLOPPY INNER TRACKS WITH HEX (0B6DB6)(015AA5)
 SF'6 - WRITE WINCHESTER INNER TRACKS WITH HEX (0B6DB6)(015AA5)
 SF'7 - VERIFY WINCHESTER SUPPRESSING RETRIES.
 SF'8 - ALTERNATE SECTORS TEST

STOP KEY DESIRED SPECIAL FUNCTION KEY

: _

5. While observing the screen, select Special Function Key 6 (SF'6) to write on inner tracks of the Winchester. The message below appears quickly during the time that the worst-case data pattern is being written on the last two (inner) tracks of the disk.

 WRITING WORST CASE PATTERN FROM LOCATION xxxxx TO LOCATION xxxxx

6. Observe that after the data is written, the primary menu is again displayed on the screen.
7. Select SF'2 from the primary menu.
8. Key RETURN in response to the following prompt.

LVP PHASE LOCK LOOP PROGRAM

KEY SF'16 TO RETURN TO MENU

KEY RETURN WHEN READY TO ADJUST WINCHESTER

The program will now initiate a continuous read operation on the last two tracks of the disk and display a single period (.) upon successful completion of each read operation (partial program shown on the following page). If an error occurs, no retries are performed, and an error message is displayed instead of a period.

LVP PHASE LOCK LOOP PROGRAM

KEY SF'16 TO RETURN TO MENU

ADJUSTING WINCHESTER.....

9. Adjust potentiometer R7 to the midpoint of its "error-free range" as follows:
 - a. Rotate R7 until only dots appear on the screen. Allow at least one line of dots to appear without any errors.
 - b. Rotate R7 counterclockwise until errors are observed. Then rotate R7 clockwise stopping at the point that errors subside. Allow at least one line of dots to appear without any errors.
 - c. Count the number of half-turns and rotate R7 clockwise until errors are observed.
 - d. Count the number of half-turns and rotate R7 counterclockwise until the errors subside.
 - e. Subtract the number of half-turns counted in step d from that in step c. If this difference is less than three half-turns (1-1/2 turns), replace the board.
 - f. Divide the difference recorded in step e by two. Turn R7 counterclockwise this number of half-turns.

NOTE

Adjustment of the PLL for the
 Winchester Drive is now complete.

10. Key SF'16 to return to the primary menu.
11. If running Utility 732-0009A, Insert a 2.5 (or higher) operating system diskette into the DSDD drive.
12. Select SF'1 from the primary menu.
13. Key RETURN in response to the following prompt.

LVP PHASE LOCK LOOP PROGRAM

KEY SF'16 TO RETURN TO MENU

MOUNT TEST PLATTER IN FLOPPY
 KEY RETURN TO CONTINUE

The program will now initiate a continuous read operation on the last two (inner) tracks of the diskette and display a period (.) upon successful completion of each read operation (partial program shown on screen display below). If an error occurs, no retries are performed and an error message is displayed instead of a period.

LVP PHASE LOCK LOOP PROGRAM

KEY SF'16 TO RETURN TO MENU

ADJUSTING FLOPPY.....

14. Adjust potentiometer R8 to the midpoint of its "error-free range" as follows:
 - a. Rotate R8 until only dots appear on the screen. Allow at least one line of dots to appear without any errors.
 - b. Rotate R8 counterclockwise until errors are observed. Then rotate R8 clockwise stopping at the point that errors subside. Allow at least one line of dots to appear without any errors.
 - c. Count the number of half-turns and rotate R8 clockwise until errors are observed.
 - d. Count the number of half-turns and rotate R8 counterclockwise until the errors subside.
 - e. Subtract the number of half-turns counted in step d from that in step c. If this difference is less than three half-turns (1-1/2 turns), replace the board.
 - f. Divide the difference recorded in step e by two. Turn R8 counterclockwise this number of half-turns.
15. Key SF'16 to return to the main menu.
16. Insert a blank or scratch work diskette into the DSDD Drive.
17. Re-run the adjustment utility program selecting SF'0 from the primary menu to format the work diskette. Observe that the following menu is displayed after SF'0 is keyed.

LVP PHASE LOCK LOOP PROGRAM

KEY SF'16 TO RETURN TO MENU

FORMAT WHICH PLATTER? (F - FIXED OR R - REMOVABLE)

CAUTION

DO NO CONTINUE THIS PROGRAM IF CUSTOMER DATA RESIDES ON THIS DISK. PLEASE INSTALL A SCRATCH FLOPPY DISK.

- 18. Enter R an then key RETURN to format the diskette.

When the format operation is complete, the program automatically writes a worst case data pattern on the last two inner tracks of the diskette. (An option is available from the primary menu to write worst case data on the inner tracks without having to format the diskette.)

- 19. Select SF'1 from the primary menu. Observe the following prompt.

```
LVP PHASE LOCK LOOP PROGRAM
KEY SF'16 TO RETURN TO MENU
MOUNT TEST PLATTER IN FLOPPY
KEY RETURN TO CONTINUE
```

- 20. Key RETURN and observe following prompt.

```
LVP PHASE LOCK LOOP PROGRAM
KEY SF'16 TO RETURN TO MENU
ADJUSTING FLOPPY.....
.....
```

- 21. Allow the program to run a minimum of 15 minutes and observe two full screens of dots. If an error occurs before two full screens are filled up with dots, repeat step 14 to re-adjust potentiometer R8.

NOTE

If errors still occur after a second adjustment of R8, troubleshoot the disk system.

- 22. To test diskette interchangeability, obtain two known good diskettes formatted and written on from other systems (not the system under test) known to be operating properly.
- 23. Insert one diskette into the test system and run the VERIFY check on it using the sequence given below. Repeat for the second diskette.

```
VERIFY R (0, 3873)
(RETURN)
```

24. No errors should be listed on the screen. If any are, repeat step 14. If any are listed after the second adjustment, troubleshoot the disk system.

NOTE

Adjustment of the PLL for the
DSDD Drive is now complete.

E. ADJUSTMENT PROCEDURE 3

This adjustment procedure consists of two separate tests designed to help the CE diagnose Winchester disk drive problems. The first is the Verify Winchester Suppressing Retries Test and the second is the Check Alternate Sector Test.

The Winchester Suppressing Retries test is used where intermittent I93 and I96 errors occur and a standard verify test does not show any bad sectors. The Winchester Suppressing Retries test will produce a dot on the CRT each time the Winchester drive makes a complete verification (one pass) of the disk surface. A bad sector is indicated if the same sector address occurs more than three times in 25 passes. If a sector address is suspected of being bad, a disk reformat is required.

The Check Alternate Sector Test is used in two ways. First to verify that a marginal sector does get an alternate sector assigned after formatting. Second to determine if a Winchester drive has an excessive number of alternate sectors. If a disk surface has in excess of 25 alternate sectors, a phase-lock-loop adjustment along with a reformat should be performed.

The step-by-step procedure for executing the Winchester Suppressing Retries Test and the Alternate Sectors Test is as follows:

1. Load Utility Program 732-0009B.
2. Select Special Function #7 and allow the program to run a minimum of 30 minutes.
3. Observe that a dot appears on the screen each time one verification pass of the Winchester drive is completed.
4. Record all errors reported. If the same error (sector address) is reported more than three times in 25 test passes (25 dots), the CE should:
 - a. Perform steps 1 through 9f of Adjustment Procedure 2.
 - b. Backup all customer data.
 - c. Reformat the Winchester.

5. Select SF'16 to return to the main menu. Select Special Function #8 (Alternate Sector map) and observe following prompt:

```

WINCHESTER ALTERNATE SECTOR MAP DISPLAY
KEY RETURN FOR MAIN MENU
DRIVE ADDRESS D
    
```

6. Input the drive address (D11, D12, D21, D22, D31 or D32).
7. Key RETURN and observe the alternate sector map for listing of bad sectors (sector appearing 3 or more times is considered bad) as follows:

ALTERNATE MAP FOR PLATTER D11

WANG SECTOR #	WINCHESTER				
	CYLINDER	HEAD	SECTOR	START BYTE	END BYTE

(Bad Sectors)

- .
- .
- .
- .
- .

END OF THE LIST - HIT ANY KEY TO RUN AGAIN

8. Carefully verify that any sector address (error) reported three or more times in step 4 (Special Function #7) is also reported in the Alternate Sector map (after re-formatting Winchester drive).

NOTE

Other addresses not reported three or more times in SF'7 may appear in the Alternate Sector map.

9. Re-run steps 1 through 4 to verify correct Winchester Drive operation.

NOTE

No error should be listed more than two times on the screen. If any error is listed more than twice after the second adjustment, troubleshoot the disk system.

PRODUCT SERVICE NOTICE

DATE : 2/17/81

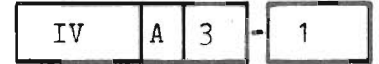

CLASSIFICATION 2200 SYSTEMS

CATEGORY MAINFRAMES

PRODUCT/APPL. VP/LVP/MVP/SVP

SEQUENCE # 1

TITLE:

CHANGES AND ADDITIONS TO MODEL 2200LVP
PRODUCT MAINTENANCE MANUAL, WL# 729-0602 (IV.A.3)

This PSN contains information concerning the following topics:

- A. Setting the device address switch on the WL# 210-7694 2200/Disk Interface board (3-board DPU--Disk Processing Unit).
- B. PROM numbers and loading scheme for the different versions of the WL# 210-7696-X Microcomputer/Memory board (3-board DPU).
- C. Setting Switchbank 1 (SW1) on the WL# 210-7696-X Microcomputer/Memory board (3-board DPU).
- D. Disk drive models supported on the LVP.
- E. Power requirements and environmental specifications.
- F. Control Memory address assignment on the WL# 210-7588-1A board.
- G. 2200LVP troubleshooting hints.
- H. SA850/851 DSDD Diskette Drive alignment PROM.
- I. Modifications to the 3-board DPU.
- J. New 8600-series DPU boards.

IV.A.3-1

- A. Figure 8-13, WL# 210-7694 2200/Disk Interface (DPU), on page 8-11 is incorrect. The HEX values of the individual switches in the device address switchbank (SW1) are reversed--switch #1 is HEX 80 and switch #8 is HEX 01. (See figure below.)

HEX VALUE	ON
80	----- 1
40	----- 2
20	----- 3
10	----- 4
8	----- 5
4	----- 6
2	----- 7
1	----- 8

- B. Figure 8-15, WL# 210-7696-A Microcomputer/Memory (DPU), on page 8-13 is incorrect. The PROM numbers and loading scheme are as follows.

LOCATION	210-7696-A (4 OR 8 MB WINCHESTER)	210-7696-B (2 OR 8 MB WINCHESTER)
L29	378-4220	378-4220
L28	378-4221	378-4221
L27	378-4222	378-4222
L26	378-4223	378-4230

- C. Figure 8-15, WL# 210-7696-A Microcomputer/Memory (DPU), on page 8-13 is incorrect. The settings for switchbank SW1 are as follows. (If the revision levels of the PROM's on the 210-7696-X board are R5 or higher, switch #3 must be OFF; otherwise, switch #3 must be ON. See item I in this PSN.)

NOTE: 1 = ON and 0 = OFF.

WL# 210-7696-A (4 or 8 MB Winchester Disk Drive):

<u>CONFIGURATION</u>	<u>SWITCHES</u>							
	<u>1</u>	<u>2</u>	<u>3</u>	<u>4</u>	<u>5</u>	<u>6</u>	<u>7</u>	<u>8</u>
Diskette drive only (for test purposes only)	1	1	0	1	1	0	1	1
4 MB Winchester only (for test purposes only)	1	1	0	0	1	1	1	1
8 MB Winchester only (for test purposes only)	1	0	0	1	1	1	1	1
4 MB Winchester and diskette drive	1	1	0	0	1	0	1	1
8 MB Winchester and diskette drive	1	0	0	1	1	0	1	1

↑

SW. 3 OFF FOR RS PROM OR HIGHER
ON 96 BOARD

↓

WL# 210-7696-B (2 or 8 MB Winchester Disk Drive):

<u>CONFIGURATION</u>	<u>SWITCHES</u>							
	<u>1</u>	<u>2</u>	<u>3</u>	<u>4</u>	<u>5</u>	<u>6</u>	<u>7</u>	<u>8</u>
Diskette drive only (for test purposes only)	1	1	0	1	1	0	1	1
2 MB Winchester only (for test purposes only)	1	1	0	0	1	1	1	1
8 MB Winchester only (for test purposes only)	1	0	0	1	1	1	1	1
2 MB Winchester and diskette drive	1	1	0	0	1	0	1	1
8 MB Winchester and diskette drive	1	0	0	1	1	0	1	1

- D. The disk drive models supported on the LVP are incorrectly stated on page 1-3. The supportable drive models are 2260B/BC/C and 2270A.
- E. The power requirement given on page 1-9 is incorrect. The proper figure is 383 Watts not 230 Watts. Also, a dedicated power line is recommended for the LVP CPU.
- The temperature specification given on page 1-9 is incorrect. The recommended temperature range is 60° to 80°F (15° to 27°C).
- F. Figure 12-1, Control Memory Diagnostic Error Interpretation, on page 12-24 is incorrect. The bottom two rows of RAM's are addresses HEX 0000-3FFF and the top two rows are HEX 4000-7FFF.
- G. Add the following troubleshooting information to Section 12.

Error indication: Flashing light on diskette drive door.

- a) Replace WL# 210-7696 CPU board.
- b) Replace WL# 210-6793-1 CPU board.

Error indication: I93 or I96 from the Winchester disk drive.

- a) Replace WL# 210-7694 DPU board.
- b) Replace WL# 210-7695-A DPU board.
- c) Replace Winchester drive.

Error indication: I93 or I96 from the DSDD diskette drive.

- a) Replace media.
- b) Replace WL# 210-7694 DPU board.
- c) Replace WL# 210-7695-A DPU board.
- d) Replace diskette drive.

NOTE:

Check all switch settings and power supply voltages prior to running any diagnostic tests.

- H. An alignment PROM (WL# 378-4252) is available to allow the Customer Engineer to perform any required adjustments on a diskette drive whenever BASIC-2 cannot be loaded. Documentation explaining how to use the alignment PROM is also available and should be received with the PROM when the PROM is ordered. Add this information to Section 11.
- I. Extensive modifications have been made to the WL# 210-7694, WL# 210-7695-A, and WL# 210-7696-A, -B DPU boards. Make any changes to the LVP manual, concerning the following information, where appropriate.

Logistical Information

To facilitate the updating of existing 2200LVP units, the Logistics Department is developing a DPU "swap" procedure. Basically, a set (one for each customer and/or field unit supported) of completely updated DPU boards will be sent to Branch Offices now supporting 2200LVP units--the old boards will be returned to the Home Office. When the Logistics Department finalizes the "swap" procedure, they will supply each Branch Office concerned with the exact details. DO NOT CALL THE LOGISTICS DEPARTMENT CONCERNING THIS MATTER!

All newly manufactured 2200LVP units (i.e., shipped after 11/18/80) will contain the updated DPU boards.

Technical Information

The E-REV levels of the updated boards have been set back to "1".
 The numbers of the ECO's that result in this resetting of the E-REV level are: 16884 on the 210-7694 board, 16885 on the 210-7695-A, and 16886 on the 210-7696-A, -B.

The updated boards can be recognized by the following distinguishing features.

210-7694: L5 contains an IC socket
 L8 is a 74S74
 L9 is a 74LS04
 Potentiometers are gyp tolled

210-7695: L37 contains a 74S32

210-7696: PROM's are R5
 L8 is a 74LS04
 L19 is a 74LS04

With these latest ECO's incorporated:

-- A change must be made to the WL# 210-7698 CPU/DPU Motherboard.
Only units with serial numbers 1000-1043 require this ECO; units with serial numbers above 1043 have the change incorporated. The procedure for modifying the motherboard follows.

1. Set the CPU ac power switch off.
2. Remove the CPU chassis cover and all DPU circuit boards.
3. On the component side of the motherboard, cut the etch that joins connector 2 pin 8 of the 210-7695 board slot to the disk and diskette drive fingerboard connectors 1 and 2 pins 2 (ref: FIGURE 1).
4. On the non-component side of the motherboard, add a wire from the disk and diskette fingerboard connectors 1 and 2 pins 2 to connector 3 pin 6 of the 210-7695 circuit board slot.

5. Run a disk/diskette diagnostic to check for correct operation of the unit, and then reinstall boards and cover.

-- Switch 3 of switchbank SW1 on the WL# 210-7696-A (-B) board must be set OFF. (See item C in this PSN.)

-- The total available sectors on the DSDD Diskette Drive is 3874 (sector addresses 0-3873) plus one track (the first track on side 0) of single-density. The available sectors provide storage for 998,400 bytes of data. These figures reflect the change in tracks/surface from 77 to 75.

-- Formatting time for the Winchester Disk Drive is approximately 13 minutes.

-- Formatting time for the DSDD Diskette Drive is approximately 2 minutes.

-- The PLO adjustment is no longer to be performed in the field. The potentiometers will be glyptalled after the adjustment has been performed by manufacturing or a repair depot.

J. All ECO's applicable to the 7600-series DPU boards have been incorporated into the artwork of the boards, which is the normal procedure; however, three new part numbers have been generated for these updated boards. The new boards have been given 8600-series numbers, that is, 210-8694, 210-8695-A, and 210-8696-A, -B. These new boards are electrically identical to the existing 7600-series boards; therefore, they are completely interchangeable. All switch settings and PROM loadings for the 8600-series boards are also the same as for the updated 7600-series.

One new feature is available with the 8600-series boards. Four (4) diagnostic error interpretation LED's have been added to the WL# 210-7696-A, -B board providing visibility into the power-on diagnostic. Refer to documentation category IV.C.1 for detailed information concerning the DPU power-on diagnostic and the error messages displayed on the LED's.

PRODUCT SERVICE NOTICE

DATE : 3/30/81

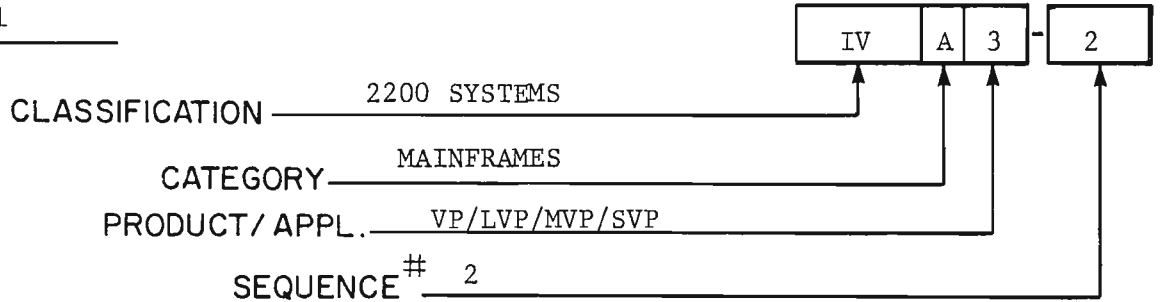

TITLE:

CORRECTION TO STATEMENT D IN PSN IV.A.3-1

Statement D in PSN IV.A.3-1 concerning disk drive models supported on the LVP has caused some confusion in the field. This PSN is written to clear up any misunderstandings that may have resulted from that statement.

The 2280 (Phoenix) CMD is the optional disk drive sold for, and supported by, the 2200 LVP. The 2260B/BC/C and 2270A drives are supported on the 2200 LVP only if these drives are part of a 2200 system being UPGRADED to an LVP. This provides the user with the option of keeping these drives rather than purchasing a 2280 CMD if additional off-line storage is needed. The 2260B/BC/C and 2270A drives are NOT available as purchasable options on the 2200 LVP.



PRODUCT SERVICE NOTICE

DATE : 3/18/82

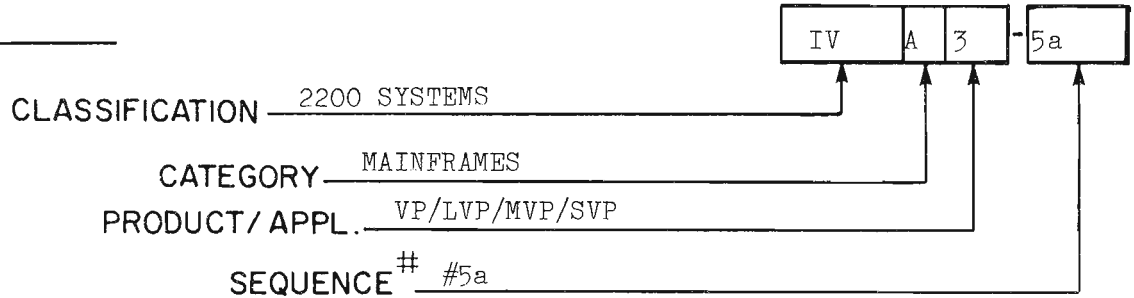

TITLE:

2200LVP/SVP: WP# 210-7694/8694 PLL ADJUSTMENT

This Notice documents the adjustment procedure for the phase-locked loop (PLL) on the WL# 210-7694 or WL# 210-8694 board in the 2200LVP/SVP Disk Processing Unit (DPU). This adjustment procedure supercedes that given in Model 2200LVP Product Maintenance Manual, WL# 729-0602 (IV.A.3.M), Section 11.

A. REQUIRED TOOLS/TEST EQUIPMENT

- PLL adjustment utility program diskette (WL# 732-0009A).
- Oscilloscope.
- Small slot screwdriver.
- Short length of jumper wire.
- Operating System diskette.
- One DSDD work diskette.
- Two DSDD diskettes that were formatted in different units (other than the unit under test).

B. ADJUSTMENT PROCEDURE (ref: FIGURE 1)

NOTE:

- a) Be certain the "reference" diskettes are error free.
(Use fresh new diskettes whenever possible)
 - b) Switch ac power OFF prior to removing/inserting any logic board from/into the unit.
 - c) The Operating System does not have to be loaded to perform steps 1-15 below.
 - d) All references to test points, IC pins, potentiometers, etc. pertain to the 210-7694/8694 board.
 - e) Wires inserted into plate-through holes are available on the noncomponent side of the board to connect the oscilloscope probe to when performing steps 2, 7, and 8.
 - f) Steps 1-15 below are only a preliminary adjustment; steps 16-34 constitute the final adjustment.
-
- 1. Using a jumper wire, connect TP1 (Test Point #1) to +0V.
 - 2. Connect the oscilloscope Channel 1 probe to L5 pin 1 or 2.
 - 3. Connect the oscilloscope ground lead to +0V.
 - 4. Set the oscilloscope controls such that a +4.0V dc level can be observed.
 - 5. Adjust potentiometer R16 until a +4.0V dc level is observed.
 - 6. Carefully remove the jumper wire from TP1.
 - 7. Connect the oscilloscope Channel 1 probe to L8 pin 11 (phase detector reference clock).
 - 8. Connect the oscilloscope Channel 2 probe to L4 pin 6 (voltage controlled oscillator--VCO--output).
 - 9. Set the oscilloscope controls as follows.

Display Mode: Alternate
Trigger Source: Channel 1
Trigger Mode: Normal (dc coupling)
Trigger Slope: Positive
Time Base: 0.1 usec/div
Vertical Sensitivity: 2V/div
Input Coupling: dc

NOTE: TP6 IS L6-9 ON 210-7694 BOARD

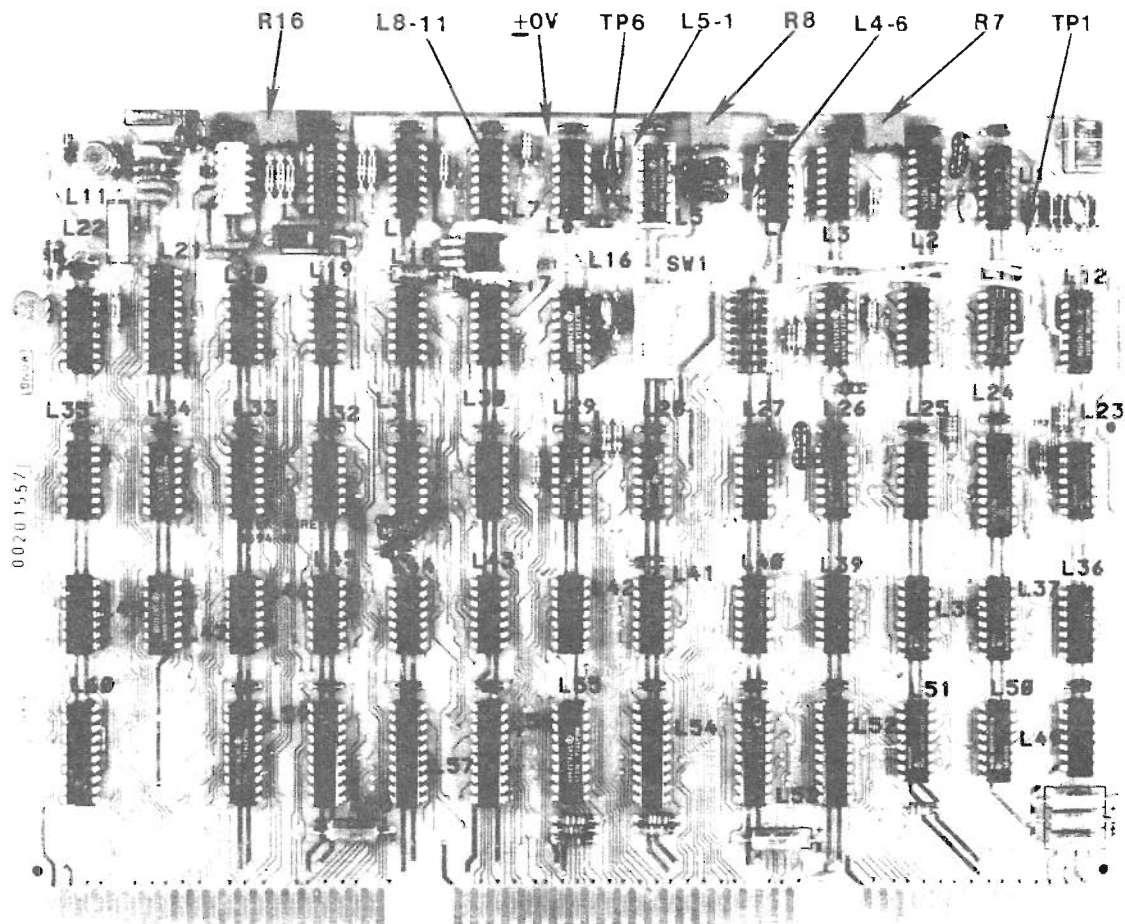

FIGURE 1 WL NO. 210-8694 TEST POINTS AND POTENTIOMETERS

10. Turn potentiometer R7 (Winchester drive adjustment) completely counterclockwise, and then slowly adjust R7 clockwise until the VCO output signal (Channel 2) is stable--not free running. Continue adjusting R7 until all the VCO output pulses are centered with respect to the phase detector reference clock pulses (ref: FIGURE 2). When this condition occurs, the PLL is said to be "locked". When the output pulses are centered, the signal will have a period of approximately 0.115 usec (ref: FIGURE 2). FIGURE 3 shows an incorrect VCO output signal. Note that the higher frequency of the VCO output in the figure results in an extra pulse (ten instead of nine) in the VCO output.

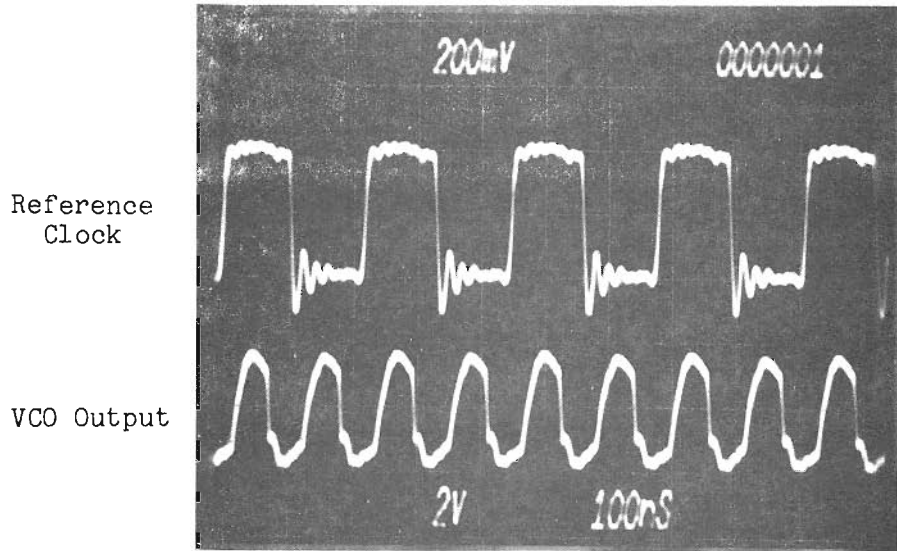

FIGURE 2 PLL CORRECTLY ADJUSTED FOR WINCHESTER DISK DRIVE

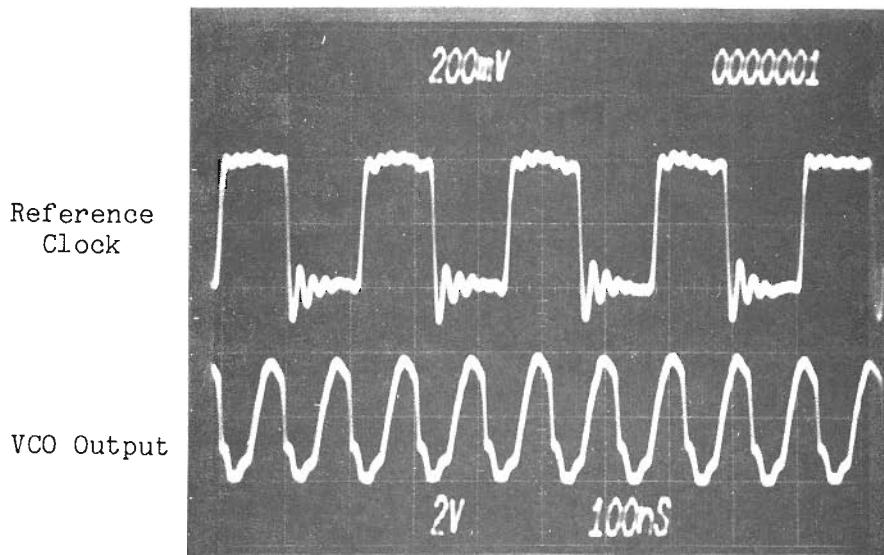

FIGURE 3 PLL INCORRECTLY ADJUSTED FOR WINCHESTER DISK DRIVE

11. NOTE: Perform this step several times to ensure proper adjustment.

Verify that the adjustment is correct by connecting a jumper wire from TP6 on the 210-8694 board or L6-9 on the 210-7694 board to $+0V$ and then removing the wire. This momentarily selects the diskette drive frequency. The PLL should "lock back up" on the Winchester disk drive frequency when the jumper is removed. That is, the VCO output should automatically return to a stable, not free-running, display. If the PLL does not "lock up" (ref: FIGURE 4), continue adjusting R7 in the clockwise direction until the conditions in step 10 are met and the PLL "locks back up" as stated above.

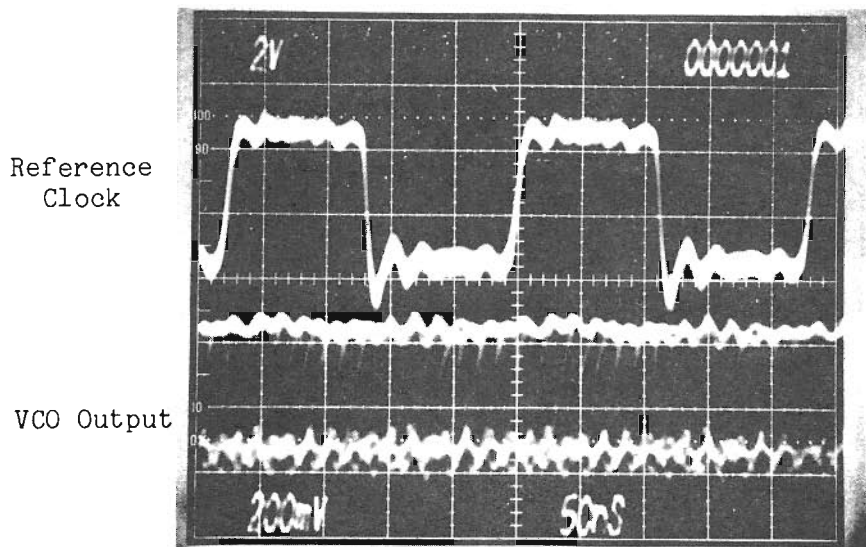

FIGURE 4 PLL NOT "LOCKED"

12. NOTE: Perform this step several times to ensure proper adjustment.

Again verify that the adjustment is correct by setting the CPU ac power switch OFF and then back ON. After setting the power ON, note the actions of the actuator damper on the Winchester disk drive. (The damper is distinguished by the yellow CAUTION sticker that is on it.) The actuator should restore the heads to track 0 and then position the heads at the last track. If any retries occur, that is a restore operation and reseek to the last track, continue adjusting R7 in the clockwise direction until the conditions in steps 10-11 are met and no retries occur as stated above.

13. Using a jumper wire, connect TP6 on the 210-8694 board or L6-9 on the 210-7694 board to $+0V$. (This selects the diskette drive frequency.)

14. Slowly adjust potentiometer R8 (diskette drive adjustment) until the leading edge of the VCO output pulse (Channel 2) occurs 0.075 usec after the leading edge of the phase detector reference clock (ref: FIGURE 5). FIGURE 6 and FIGURE 7 show incorrect VCO output signals.

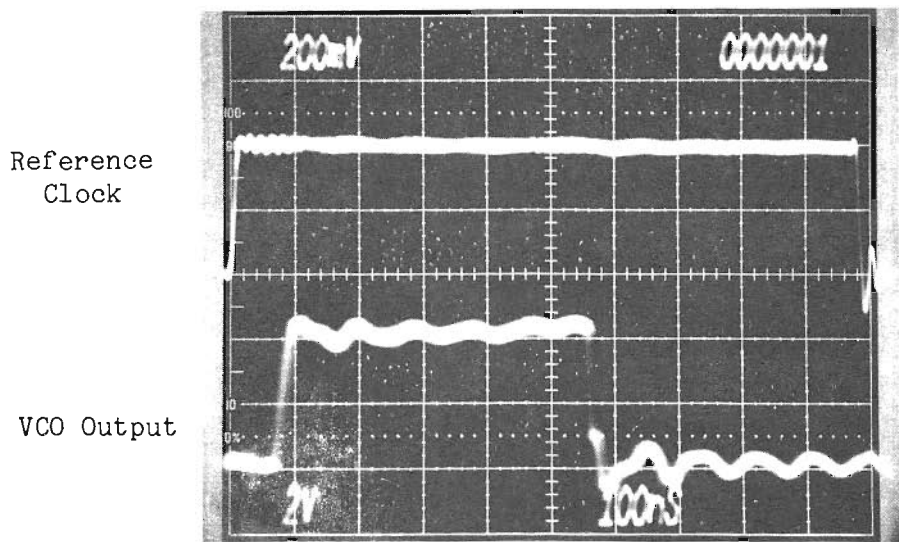

FIGURE 5 PLL CORRECTLY ADJUSTED FOR DISKETTE DRIVE

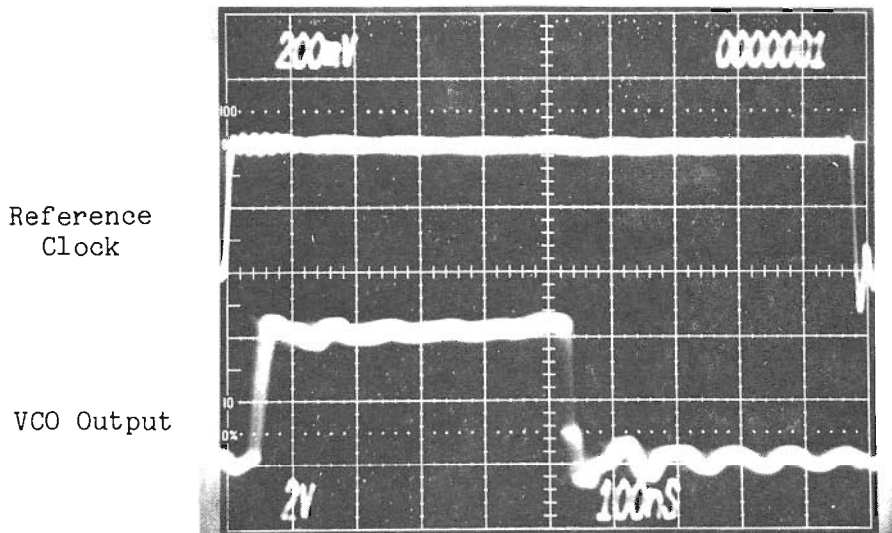

FIGURE 6 PLL INCORRECTLY ADJUSTED FOR DISKETTE DRIVE

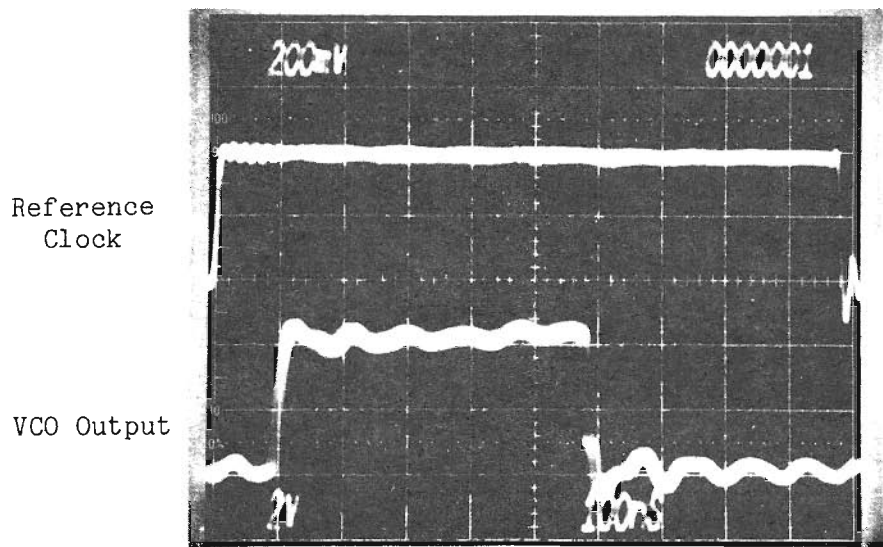

FIGURE 7 PLL INCORRECTLY ADJUSTED FOR DISKETTE DRIVE

15. Carefully remove the jumper wire from TP6.
16. Insert an Operating System (OS) diskette into the DSDD drive, load the OS, and then remove the diskette.

CAUTION:

BEFORE CONTINUING WITH THE FINAL ADJUSTMENT PROCEDURE THAT FOLLOWS, BACKUP ALL CUSTOMER DATA THAT RESIDES ON THE WINCHESTER DISK DRIVE. THE FOUR INNER MOST TRACKS OF THE DISK WILL BE WRITTEN ON.

17. Insert a PLL adjustment utility program diskette (WL# 732-0009A) into the DSDD drive.
18. Enter the following on the workstation keyboard to load and run the utility program, and then remove the diskette.

```

SELECT DISK B10
(RETURN)
LOAD RUN
(RETURN)

```

19. Select Special Function Key 6 (SF'6) to write on inner track of Winchester.

LVP PHASE LOCK LOOP PROGRAM

KEY SF' 16 TO RETURN TO MENU

- SF'0 - FORMAT PLATTERS
- SF'1 - ADJUST FLOPPY
- SF'2 - ADJUST WINCHESTER
- SF'3 - WRITE FLOPPY INNER TRACKS WITH HEX (0B6DB6)
- SF'4 - WRITE FLOPPY INNER TRACKS WITH HEX (015AA5)
- SF'5 - WRITE FLOPPY INNER TRACKS WITH HEX (0B6DB6)(015AA5)
- SF'6 - WRITE WINCHESTER INNER TRACKS WITH HEX (0B6DB6)(015AA5)
- SF'7 - VERIFY WINCHESTER SUPPRESSING RETRIES.

STOP KEY DESIRED SPECIAL FUNCTION KEY

The program writes a worst case data pattern on the last four tracks of the disk. The following message is displayed on the screen while the data pattern is being written.

WRITING WORST CASE PATTERN FROM LOCATION xxxxx TO LOCATION xxxxx

After the data is written, the primary menu returns to the screen.

20. Select SF'2 from the primary menu.

21. Key RETURN in response to the following prompt.

LVP PHASE LOCK LOOP PROGRAM

KEY SF'16 TO RETURN TO MENU

KEY RETURN WHEN READY TO ADJUST WINCHESTER

The program initiates a continuous read operation on the last track of the disk and displays a period (.) upon successful completion of each read operation (see following screen display). If an error occurs, no retries are performed and an error message is displayed instead of a period.

LVP PHASE LOCK LOOP PROGRAM

KEY SF'16 TO RETURN TO MENU

ADJUSTING WINCHESTER

.....
.....

NOTE:

The following three steps adjust R7 to the midpoint of what can be called the "error-free range".

- 21. Adjust potentiometer R7 in one direction (either direction) until a read error occurs.
- 22. While counting the number of turns of the potentiometer shaft, adjust R7 in the opposite direction until a read error occurs. (The errors will disappear and then return when the other limit is reached.)
- 23. Divide the number of turns counted by two and then adjust R7 in the original direction the number of turns calculated.

Adjustment of the PLL for the Winchester drive is now complete.

- 24. Insert a work diskette into the DSDD drive.
- 25. Re-run the adjustment utility program selecting SF'0 from the primary menu to format the work diskette.

The following menu is displayed after SF'0 is keyed.

LVP PHASE LOCK LOOP PROGRAM

KEY SF'16 TO RETURN TO MENU

FORMAT WHICH PLATTER? (F - FIXED OR R - REMOVABLE)*

NOTE:

DO NO CONTINUE IF CUSTOMER DATA RESIDES ON THIS DISK.
PLEASE INSTALL SCRATCH FLOPPY DISK...

- 26. Enter R an then key RETURN to format the diskette.

When the format operation is complete, the program automatically writes a worst case data pattern on the last four tracks of the diskette. (An option is available from the primary menu to write worst case data on the inner tracks without having to format the diskette.)

- 27. Select SF'1 from the primary menu.
- 28. Key RETURN in response to the following prompt.

```
LVP PHASE LOCK LOOP PROGRAM  
KEY SF'16 TO RETURN TO MENU  
  
MOUNT TEST PLATTER IN FLOPPY  
KEY RETURN TO CONTINUE
```

The program initiates a continuous read operation on the last four tracks of the diskette and displays a period (.) upon successful completion of each read operation (see screen display below). If an error occurs, no retries are performed and an error message is displayed instead of a period.

```
LVP PHASE LOCK LOOP PROGRAM  
KEY SF'16 TO RETURN TO MENU  
  
ADJUSTING FLOPPY  
.....  
.....
```

NOTE:

The following three steps adjust R8 to the midpoint of what can be called the "error-free range".

- 29. Adjust potentiometer R8 in one direction (either direction) until a read error occurs.
- 30. While counting the number of turns of the potentiometer shaft, adjust R8 in the opposite direction until a read error occurs. (The errors will disappear and then return when the other limit is reached.)

31. Divide the number of turns counted by two and then adjust R8 in the original direction the number of turns calculated. Select SF'5 (Write inner track on floppy). Then select SF'1 again and readjust R8 if needed.

32. VERIFY two diskettes that were formatted in different units (other than the test unit) to ensure board interchangeability.

VERIFY R (0, 3873)
(RETURN)

Adjustment of the PLL for the diskette drive is now complete.

PRODUCT SERVICE NOTICE

DATE : 11/20/81

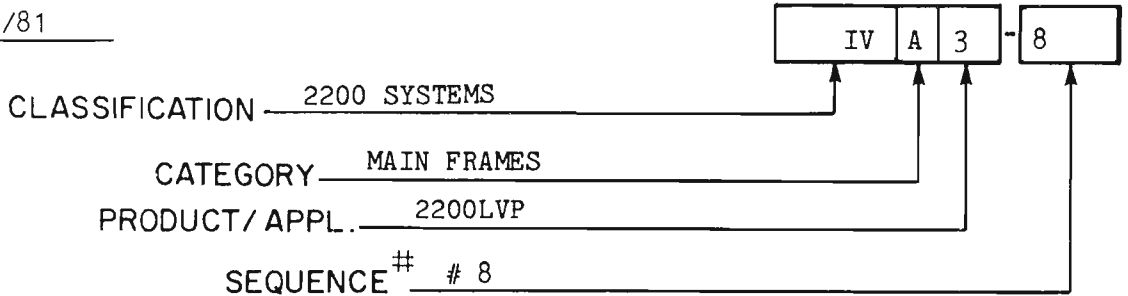

TITLE:

INSTALLATION OF OPTION 'C' INTO 2200LVP SYSTEM

SCOPE

This PSN describes the field implementation of Memory Option C into the 2200LVP CPU. A finalized version of this document will be published as an addendum to the Model 2200LVP Product Maintenance Manual, class coded (IV.A.3-M). A minor update change to the present class code will result when supplied with Option C addendum. The 2200LVP system designation changes to 2200LVPC.

GENERAL DESCRIPTION

The control and data (user) memories in the present 2200LVP Systems have a maximum control memory size of 32K and data memory of 256K. Option C upgrades the present 2200LVP System by increasing the available memory to 64K and 512K respectively. Option C provides the increased control memory size necessary to support both the 2200 COBOL and BASIC-3 languages. Included with Option C is a multiuser operating system with disk volume and file management capabilities, 2200 COBOL and BASIC-3. The Option C updated LVP CPU's have seven I/O slots for peripheral controller boards. The updated 2200LVP will be known as 2200LVPC CPU.



FIELD INSTALLATION KITS

Field Equipment Upgrades

Option C field installation kits for LVP systems are ordered by the following part numbers:

WL# 205-5028	50Hz	LVP to LVPC	Kit# UJ-5028
WL# 206-5028	60Hz	LVP to LVPC	Kit# UJ-5028

The LVPC kit contains a completely new card cage assembly with motherboard. The old card cage is removed from the LVP cabinet and replaced with the new. Existing reusable PCBs in the old card cage are removed and installed in the new card cage. New and upgraded PCBs shipped with the kit are installed to complete the new complement of boards for Option C.

The additional number of new and/or updated (PCBs) shipped in the LVPC field kit will fill the PCB complement of each LVPC.

New Factory Orders

Option C will be factory-installed on new LVPC systems per customer request prior to shipment to the field. These new systems with the desired peripherals will be shipped to a site for installation. The CE will install the new system including all necessary cabling, initial turn on and start-up. The CE will also be responsible for verifying the operation by running the new diagnostics.

Special Tools and Test Equipment

None required other than the standard items provided in the Wang CE tool kit.

FUNCTIONAL DESCRIPTION

Motherboard

A modified motherboard for 2200LVPC systems has additional slots for three more printed circuit boards. These slots will be used for two new Data (user) Memory boards and the new Extended Memory Controller (EMC) board for maximum memory. The motherboard, which is physically mounted on the card cage, has a new part number. Listed below are the new units needed to complement the LVPC systems.

1. LVPC Card Cage/Motherboard assy. (Seven I/O slots-50/60Hz).270-0467
2. One (1) Extended Memory Controller.....210-7796
3. One (1) Instruction Counter (replaces 210-6790).....210-7797

Data Memory

In order to increase the Data (User) Memory from 256K to 512K, another address bit was added. This bit is SL5 which originates on the Logibloc Registers and I/O Board 210-6793-1. This bit is set in register L46, inverted via L39-10 and presented to the motherboard as signal *PA2 at connector pin 19₂. This change (ECO #17388) is transparent to all existing 2200 motherboards.

Control Memory

Additional address decoding is also required for the increased size of control memory from 32K to 64K. To accomplish this, the address selection bits *MS1-*MS8 which were on the Instruction Counter (IC) board 210-6790, are now decoded on the new Extended Memory Controller (EMC) board (210-7796).

Instruction Counter

The new Extended Instruction Counter board 210-7797 is similar to the 210-6790 Instruction Counter except that memory select signals *MS1-*MS8 are decoded off the board. To do this, IC12-IC14 Instruction Counter bits are buffered via L58 on the EIC 210-7797 board and brought out as CI12-CI14. In addition, IC15 from register L48 is NANDed with *SWITCH at L53 producing signal *ROMS. Refer to figure below.

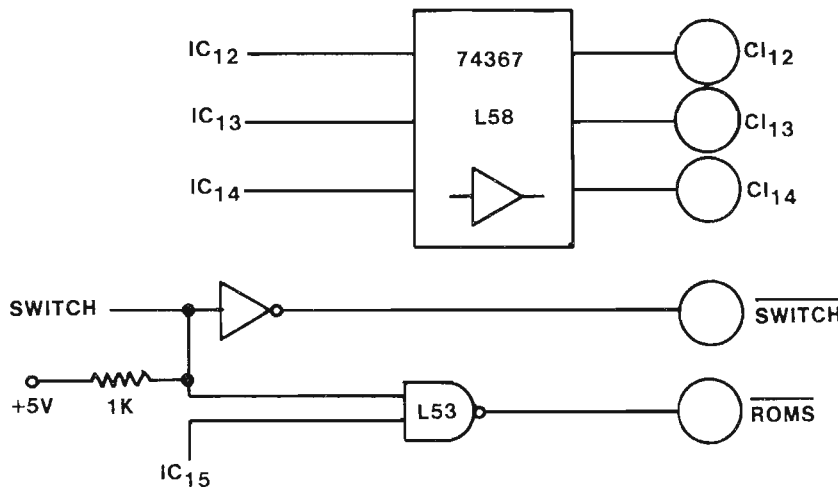

These four bits are then decoded by L12 and L4 on the Extended Memory Controller 210-7796 board as Memory Select address bits. The Instruction Counter board will only work on Extended Memory 2200 Systems. All other 2200 Systems require the use of the 210-6790 board.

Extended Memory Controller

The Extended Memory Controller board 210-7796 will perform the memory selection for both the Data and Control memory.

a. Data Memory

512K of Data Memory is structured as four 128K pages (4 separate memory boards) labelled Data Memory DM1, DM2, DM3 and DM4. These pages are selected on the Extended Memory Controller board as follows:

<u>*PA2</u>	<u>*PA1</u>	<u>SELECTION BIT</u>	<u>MEMORY SIZE</u>
0	0	*4PG	128K
0	1	*3PG	256K
1	0	*2PG	384K
1	1	*1PG	512K

IV.A.3-8

b. Control Memory

The CI12-CI14 bits and *ROMS bit (CI15) from the Instruction Counter board 210-7797 are used to decode either the lower or upper 32K of Control Memory. The lower 32K (labelled CML) is selected by *ROMS being OFF and the upper 32K (labelled CMU) by *ROMS being ON. The first 4K of upper memory is dedicated to the system bootstrap.

The bootstrap section of memory is addressed by having CI12-CI14 OFF and *ROMS (CI15) ON. Memory is configured as shown in the following figure.

Line Sketch of Memory

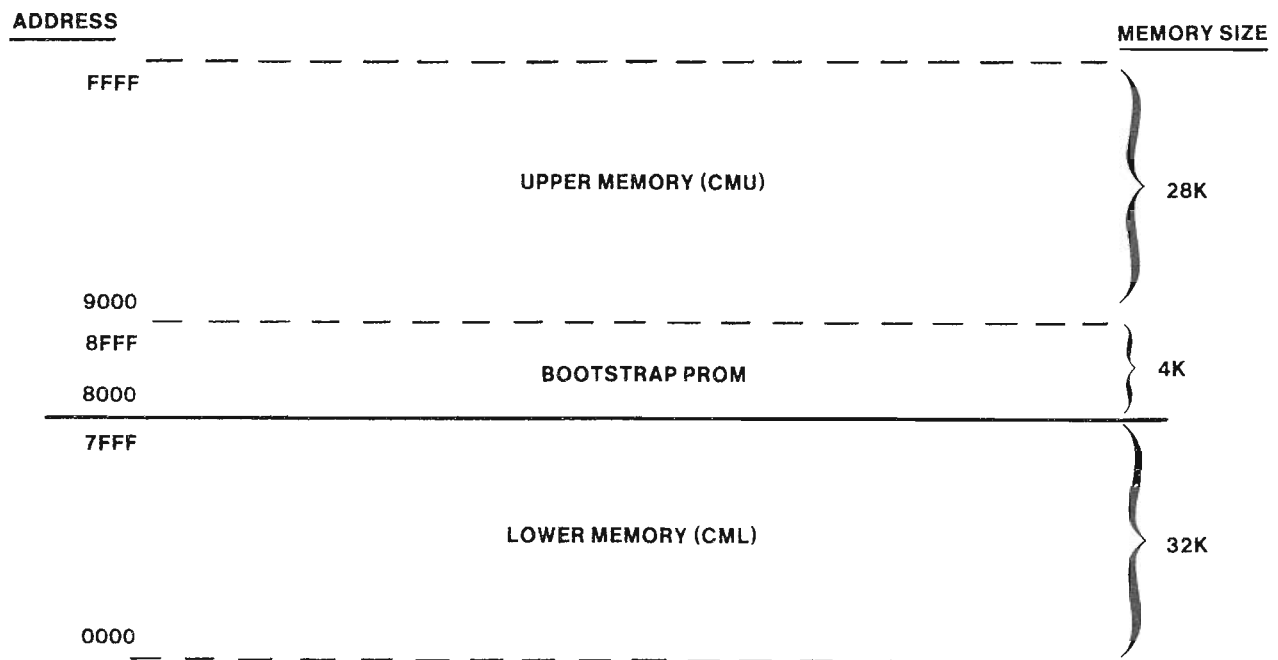

Removal of LVP Chassis

- Be sure the power is turned OFF. ON-OFF switch is on the front panel of the LVP cabinet. Unplug the power cable.
- Remove the top cover of the cabinet for access internally by removing the two screws from the rear-underneath sides of the top cover using a 5/16" nut driver (99-10). Lift the top cover out of the two snap locks and set it aside.
- Remove the lower back panel that covers the rear of the power supply by removing four (4) hex head screws with nut driver (99-10).
- Disconnect the Power Supply Harness (WL #220-1428) connector which attaches to the 6-pin Mat 'N' Lock connector on the power supply.
- Disconnect the Power Supply Harness (WL# 220-1427) which attaches to the 10-pin Molex connector on the power supply.

- f. Remove cable assembly (220-1405) connector from the bottom of the motherboard (J2).
- g. Remove the three ribbon connectors from the top edge of the motherboard (connectors 1, 2 and 3) that attach to the disk drives.
- h. Unplug cable assembly (220-1425) from fixed power supply cable connector that supplies power to the cooling fan.
- i. Disconnect cable assembly (220-1423) connector to front panel indicators.
- j. Remove card cage cover on CPU chassis. Remove existing PCBs and carefully set them aside for installation in the new chassis.
- k. Remove four screws from the rear of each corner of the CPU chassis using nut driver (99-10). Lift the chassis and remove it from the cabinet and set the chassis aside.

LVP CPU Chassis Replacement

- a. Replace the new CPU chassis with the original four screws and tighten with the nut driver (99-10). See figures 1, 2 and 3.
- b. Reconnect power connectors in steps 4, 5, 8, and 9 except for cable assembly 220-1405 which connects to J2 of the motherboard (dc power and control harness to disk drive).
- c. Plug in cabinet power cable and push power switch to ON. Be sure both cooling fans are operating and free from obstructions. Measure dc voltages at test points on motherboard 210-7799. Test points are accessible from circuit board side of the I/O section. If all voltages are present (not adjusted); turn power OFF.
- d. Complete cabling-up by plugging the cable assembly 220-1405 into J2 of the new motherboard and replace the ribbon cables on the top edge connectors of the new motherboard. The fixed disk drive has two ribbons that attach to connector 2 (50 pin) and connector 3 (20 pin) and the floppy disk drive ribbon attaches to connector 1 (50 pin).
- e. Insert all boards (reusable and new boards from the kit) into the proper connectors as illustrated in figure 4. Insert one I/O terminal controller for the data entry workstation 2236DE. The workstation will be used for checking the CPU.
- f. Turn power ON and adjust operating voltages within the tolerances specified in table 1 using a digital voltmeter. Use test points on motherboard. Refer to figure 5 for location of adjustment controls on the power supply.
- g. Bring system up and load diagnostics for testing the new chassis assembly.

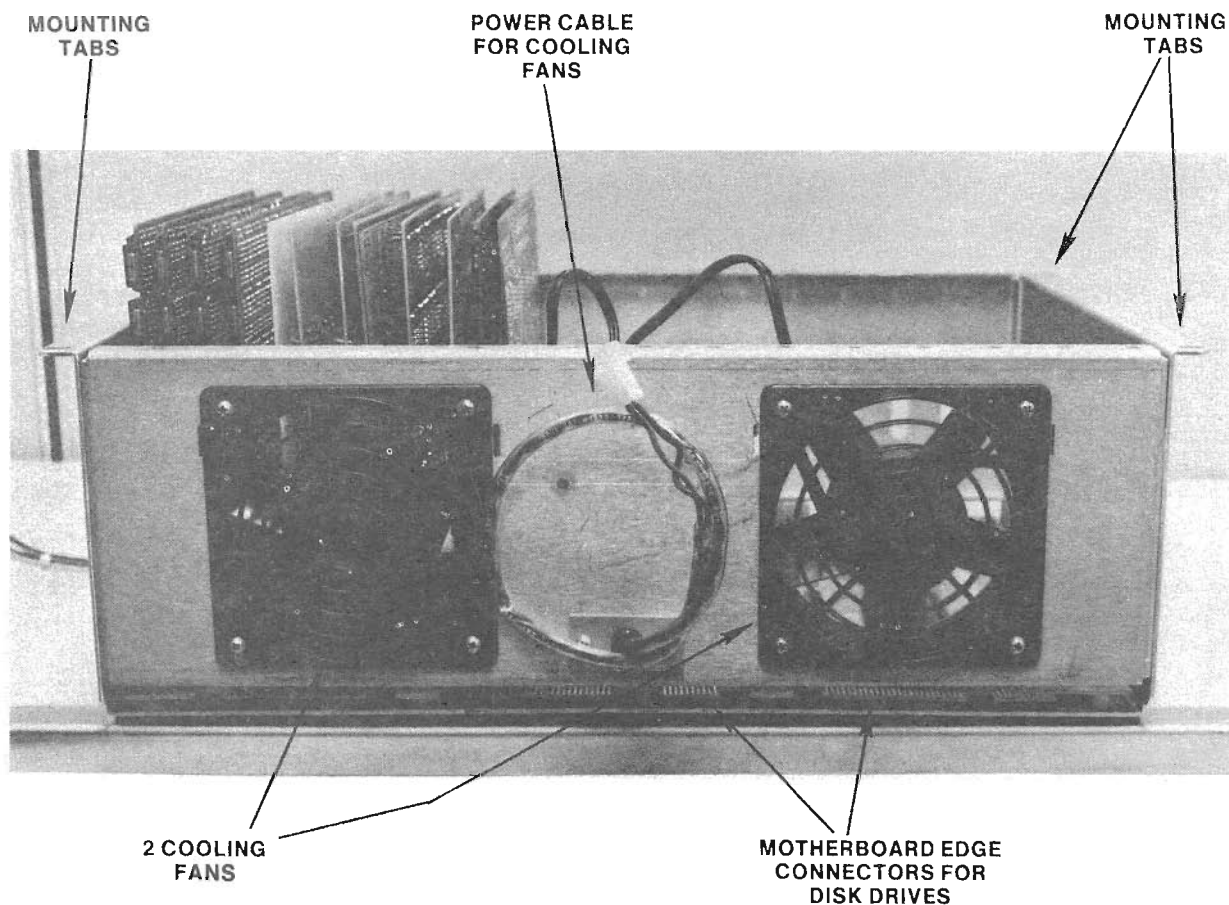

**FIGURE 1 TOP VIEW OF LVPC CARD CAGE
(NOTE TWO COOLING FANS)**

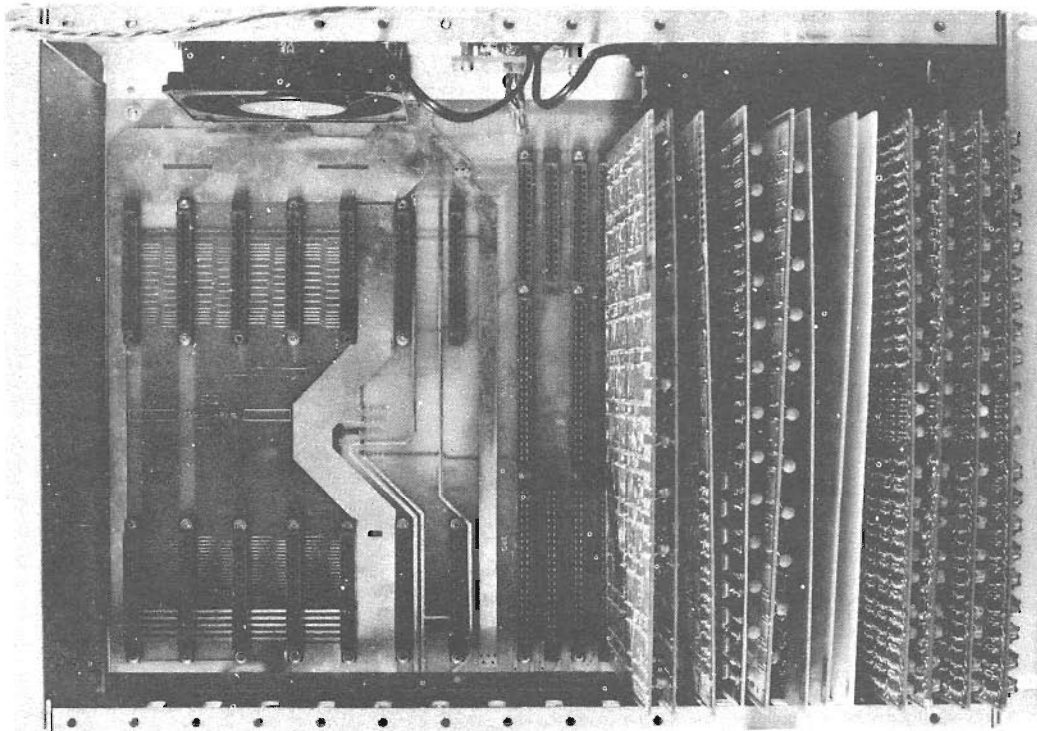

**FIGURE 2 FRONT VIEW OF CARD CAGE (LVPC)
(CIRCUIT BOARDS INSTALLED)**

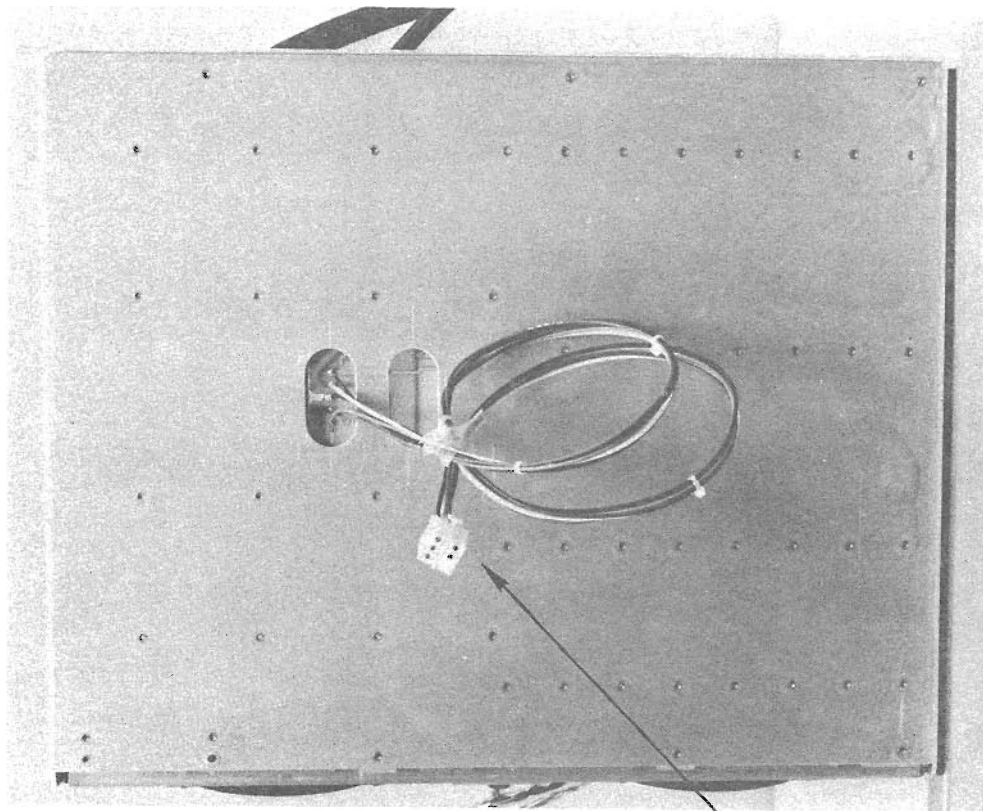

FROM POWER CABLE
FOR CARD CAGE
MOTHERBOARD
TO POWER
LIGHT

FIGURE 3 REAR VIEW OF CARD CAGE (LVPC)

NOTE

2200 CPU Diagnostics are currently available to the field. WL# 702-0138 is a single sided diskette and WL# 732-0010 is a double sided diskette. They will be used to diagnose problems for both LVP and LVPC systems.

- h. Power system down and insert the remaining I/O controller boards and connect all peripherals. Check all peripherals for proper operation.
- i. Power system down and replace all covers and panels.
- j. Power up system, load system software and perform final checks.

LVPC SYSTEM CONFIGURATION

LVPC card cage boards are inserted into slots on the new motherboard as configured in figure 4 below.

I/O	8	8	8	6	6	6	7	6	7	7	7	7	7	7
I/O	6	6	6	7	7	7	7	7	5	5	7	5	5	5
I/O	9	9	9	9	9	9	9	8	8	8	9	8	8	8
I/O	4	6	5	3	2	1	7	9	8	8	6	7	7	7

FIGURE 4 CIRCUIT BOARD LAYOUT

LVPC VOLTAGE ADJUSTMENTS

Refer to figure 5 for location of voltage adjustment potentiometers located on the rear of the power supply unit. The lower rear panel of the 2200LVP provides access holes to the voltage adjustment controls. Adjust voltages within the specifications listed in table 1.

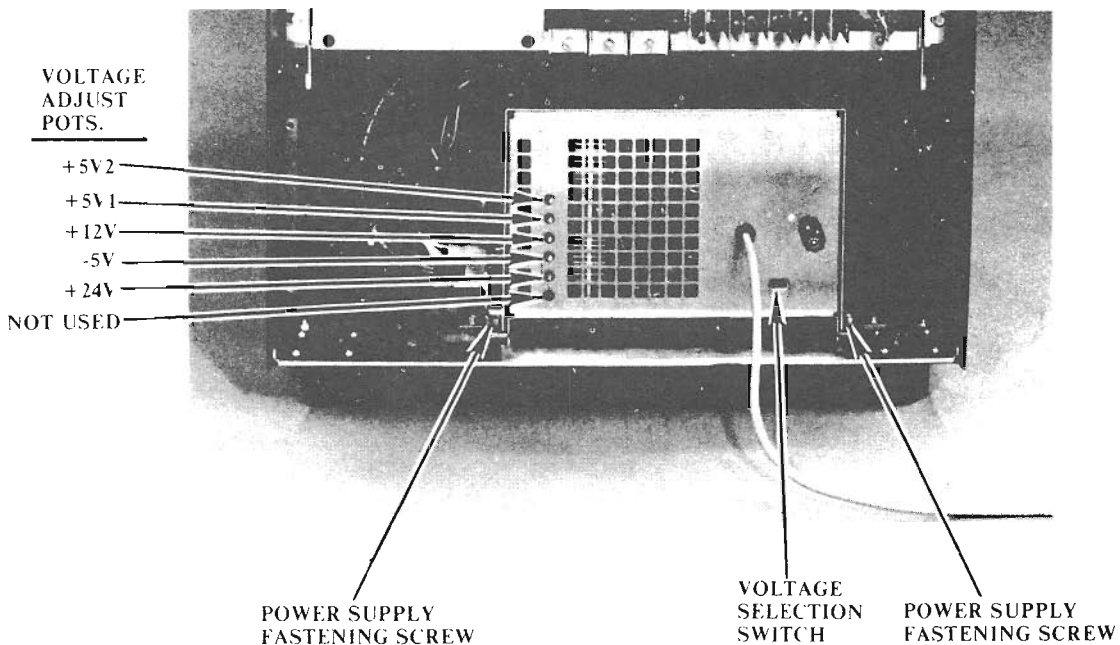

FIGURE 5 POWER SUPPLY UNIT

TABLE 1 DC VOLTAGE SPECIFICATIONS

<u>VOLTAGE</u>	<u>LIMITS</u>
+5V1*	+4.95 to +5.05 Volts
+5V2**	+4.95 to +5.05 Volts
+12V	+11.95 to +12.05 Volts
+24V	+21.60 to +26.40 Volts
-5V	-4.95 to -5.05 Volts
-12V***	-11.50 to -12.50 Volts

* If +5V1 drops below +4.7Vdc, +24V will be shut off.

** +5V2 supplies voltages for the four additional I/O slots--total seven(7).

*** -12V is not adjustable

CIRCUIT BOARD COMPLEMENT (LVPC)

	<u>EXTENDED MEMORY LVPC (7 I/O Slots)</u>
Interface, Fixed Floppy Microcomputer & Memory	210-8694
Fixed Floppy Disk Cntlr Register	210-8696
ALU	210-8695/210-8705
Stack Board	210-6793-1
Ext. Instruction Counter	210-6792
Memory Interface Bd.	210-6791
32K x 24 Bit Cntl. Mem.	210-7797
32K x 24 Bit Cntl. Mem.	210-6789
Extended Mem. Cntlr.	210-7588-1
128K x 9 Bit Data Mem.#1	210-7588-1
128K x 9 Bit Data Mem #2	210-7796
128K x 9 Bit Data Mem #3	210-7587-3
128K x 9 Bit Data Mem #4	210-7587-3
Power Supply Regulator	210-7587-3
	210-7397 (Replaces 210-6797)

DISPOSITION OF LVP CARD CAGE UNITS

Disposition of each exchanged LVP card cage requires an Equipment Transfer form WL# 700-4067B for return of exchanged equipment. The disposition of these units pertains to domestic 2200 systems only.

Return to: WANG SALVAGE OPERATIONS
51 Middlesex Street
North Chelmsford, Mass. 01863.

If the serial number sticker is missing on the card cage, return it to RDB 6854. If the unit has a sticker serial number return to RDB 6852.

Any overseas disposition of replaced LVP card cage assemblies must be coordinated with Wang International.

LIST OF SCHEMATICS FOR 2200LVP OPTION 'C'

1. 210-7796 EXTENDED MEMORY CONTROLLER (No. of sheets 2)
Used with both 2200MVP/LVP Systems
2. 210-7797 EXTENDED INSTRUCTION COUNTER (No. of sheets 4)
Used with both 2200MVP/LVP Systems
3. 210-7799 EXTENDED MEMORY MOTHERBOARD (No. of sheets 2)
Used only with 2200LVP Systems

"THIS DRAWING AND THE DATA SHOWN THEREON ARE THE CONFIDENTIAL PROPERTY OF AND ARE PROPRIETARY TO WANG LABORATORIES, INC. THIS DRAWING AND THE DATA SHOWN THEREON MAY NOT BE MADE PUBLIC WITHOUT THE WRITTEN CONSENT OF WANG LABORATORIES, INC. IF FOR ANY REASON THIS DRAWING IS PERMITTED BY WANG TO LEAVE THE PHYSICAL CUSTODY OF THE COMPANY, IT IS RETURNABLE UPON THE DEMAND OF WANG LABORATORIES, INC."

DO NOT SCALE

COMPONENT	TYPE	W.L. PART NO.
R2	4.7K 1/4W 10%	330-3047
C1-8	.047UF 100V	300-1962
C3A	82 pf 500V	300-1082
C9,10	15 UF 20V(T)	300-4022

I.C. LOCATION	TYPE	W.L. PART NO.
L1, 6-10, 16-18	SPARE	
L2,3	74367	376-0176
L4,12	7442	376-0008
L5,11	74LS32	376-0211
L13	74LS155	376-0158
L14	74LS04	376-0180
L15	74LS08	376-0153

TYPE	I.C. LOCATION	SPARE
74LS04	L14	4
74LS08	L15	2
74LS32	L11	2

MNEMONICS	COORD
1PG	IA8
2PG-4PG	IA8
CI12-CI14	IG7
DMCE	IA10
DMPAO	IA9
LE	IC11
MSIL-MS8L	IF1
MSIU	IG10
MS2U-MS8U	ID1
PA0	IE11
PA1-PA2	IF1
PROMS	IA4
ROMS	IG5
R/W1, R/W2	ID11
R/W1 DM1-R/W1 DM4	IA9
R/W2 DM1-R/W2 DM4	IA9
SWITCH	IG3

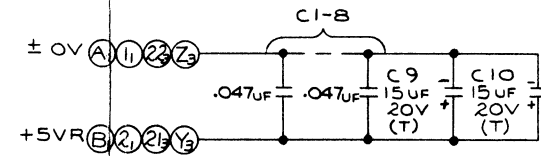
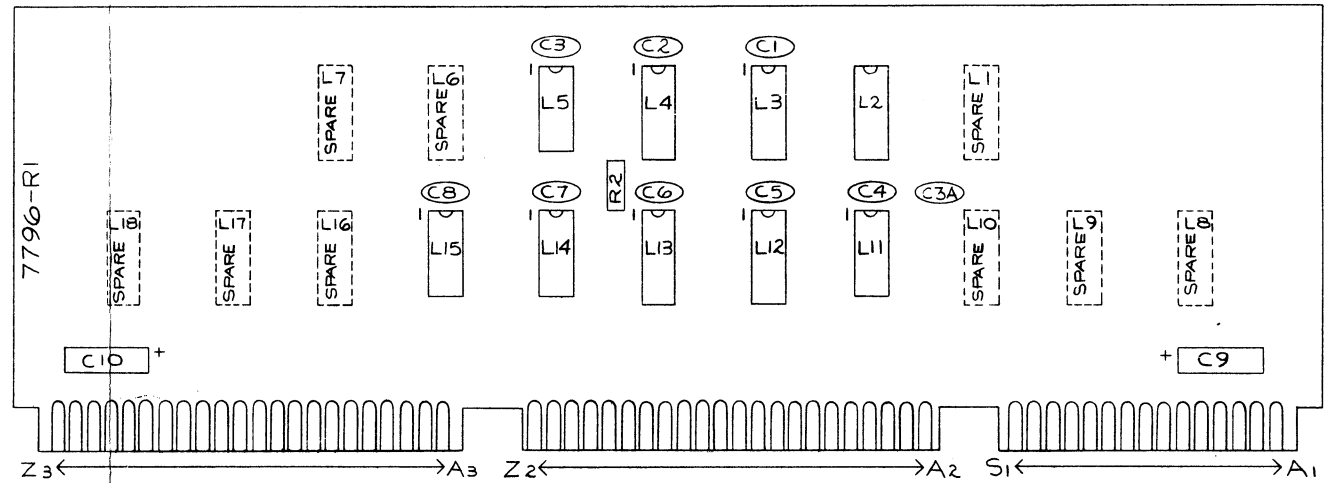
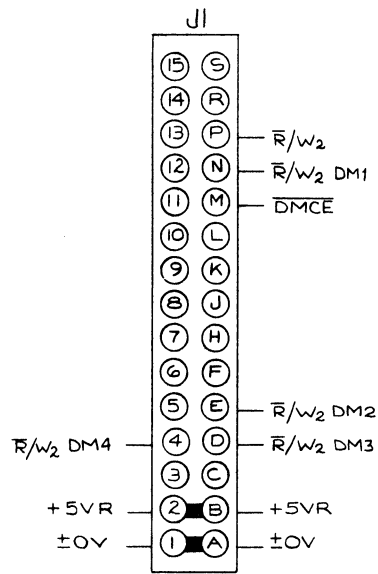
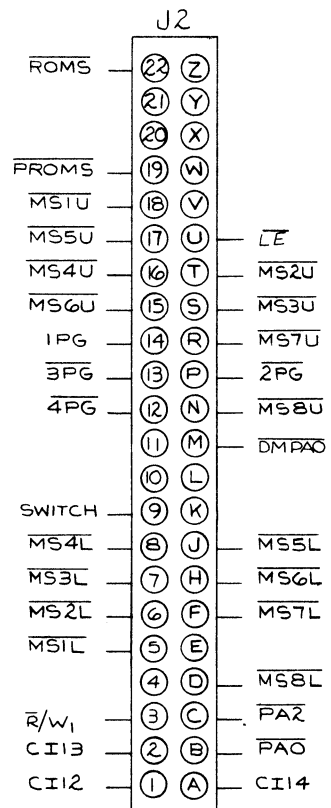
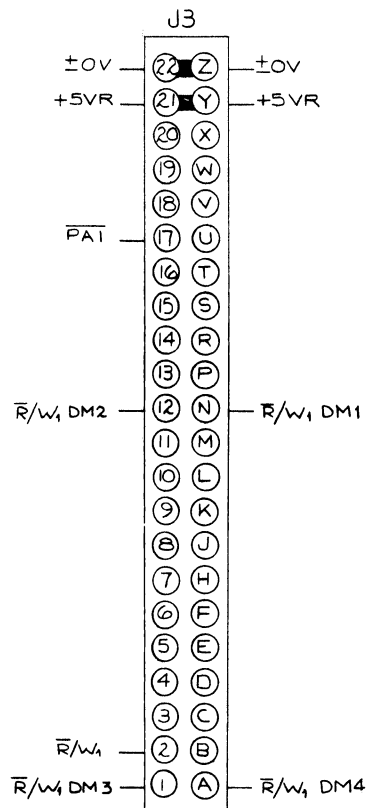

E-REV
O

REV	DATE	BY	APP'D
1	6-3-81	JED	
2	10-81	WAC	
3	1-5-81	WAC	
4	1-5-81	WAC	
5	1-5-81	WAC	
6	1-5-81	WAC	
7	1-5-81	WAC	
8	1-5-81	WAC	
9	1-5-81	WAC	
10	1-5-81	WAC	

WANG LABORATORIES, INC. LOWELL, MASS. U.S.A.		BY DWG: B. Chaffin	DATE 12-10-82	APPROVED BY E ENGR: S. J. G.	DATE 1/17/81
MATERIAL 7X		MODEL NO. 2200 LVP/MVP		TITLE EXTENDED MEMORY CONTROLLER	
FINISH 7X		TOL. EX. AS NOTED .XX ± .XXX ± ANG. ± FINISH		210-7796 D 7796 1	
SCALE 7X		SHT 2 OF 2		WANG PART NUMBER 7796	

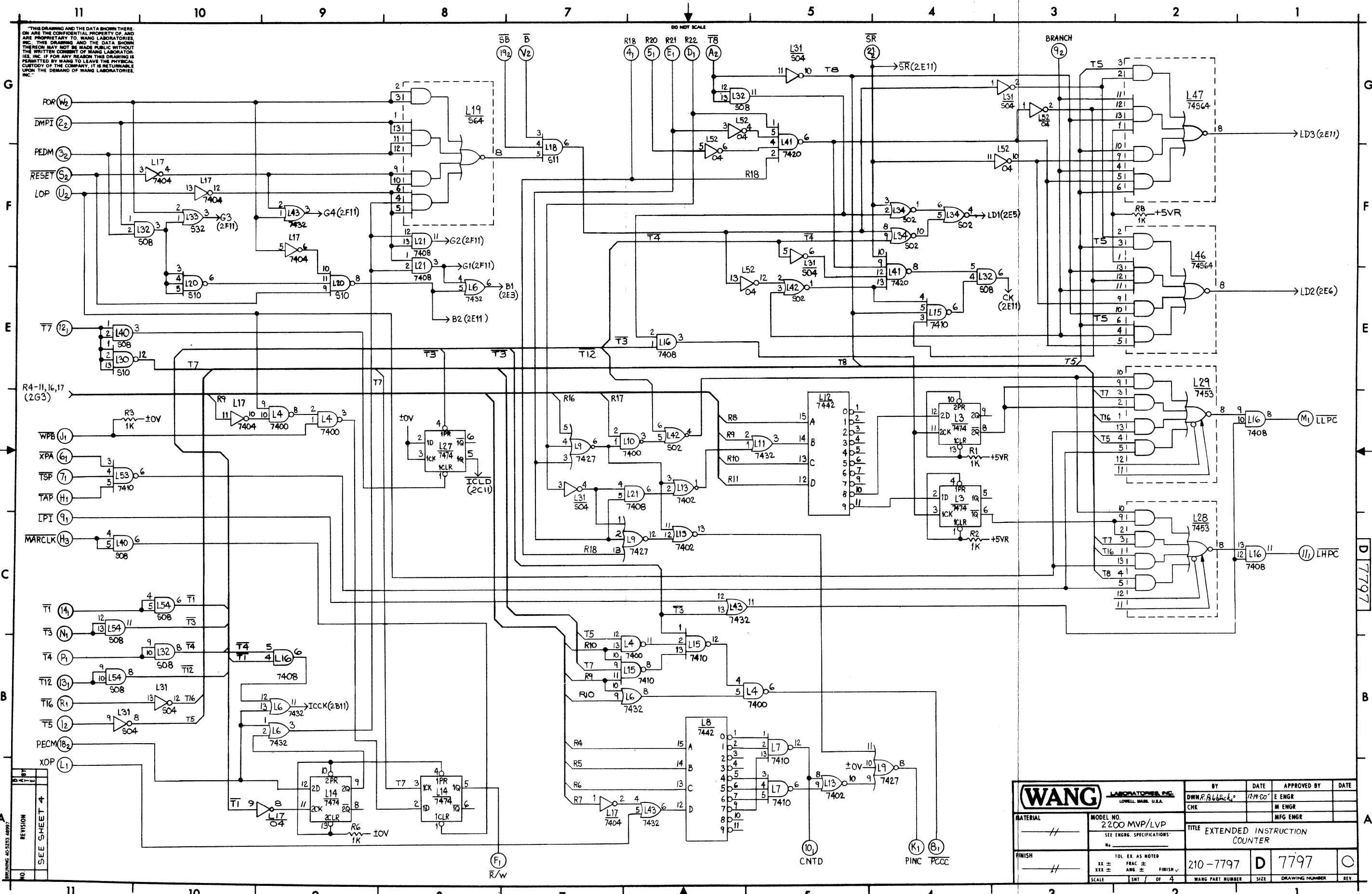

THIS DRAWING AND THE DATA SHOWN THEREON ARE THE CONFIDENTIAL PROPERTY OF, AND ARE PROPRIETARY TO, WANG LABORATORIES, INC. THE DRAWING AND THE DATA SHOWN THEREON MAY NOT BE MADE PUBLIC WITHOUT THE WRITTEN CONSENT OF WANG LABORATORIES, INC. IF FOR ANY REASON THIS DRAWING IS PERMITTED BY WANG TO LEAVE THE PHYSICAL CUSTODY OF THE COMPANY, IT IS RETURNABLE UPON THE DEMAND OF WANG LABORATORIES, INC.

NO.	REVISION	BY	DATE

SEE SHEET 4

WANG LABORATORIES, INC. LOWELL, MASS. U.S.A.		BY DWM/RAL/BRK	DATE 12/19/60	APPROVED BY E ENGR	DATE
MATERIAL //	MODEL NO. 2200 MVP/LVP	CHK		MFG ENGR	
SEE ENGR. SPECIFICATIONS		TITLE EXTENDED INSTRUCTION COUNTER			
FINISH //	TOL. EX. AS NOTED XX ± FRAC ± FINISH √ XXX ± ANG ±	210-7797	D	7797	
SCALE SMT / OF 4	WANG PART NUMBER	SIZE	DRAWING NUMBER	REV.	

11 10 9 8 7 6 5 4 3 2 1

THIS DRAWING AND THE DATA HEREIN THEREON ARE THE PROPERTY OF WANG LABORATORIES, INC. AND ARE LOANED TO YOU BY WANG LABORATORIES, INC. FOR YOUR USE ONLY. YOU SHALL NOT REPRODUCE OR TRANSMIT THIS DRAWING OR THE DATA HEREIN IN ANY MANNER WITHOUT THE WRITTEN CONSENT OF WANG LABORATORIES, INC. IF YOU ARE NOT AN EMPLOYEE OF WANG LABORATORIES, INC. YOU SHALL RETURN THIS DRAWING TO WANG LABORATORIES, INC. UPON THE DEMAND OF WANG LABORATORIES, INC.

DO NOT SCALE

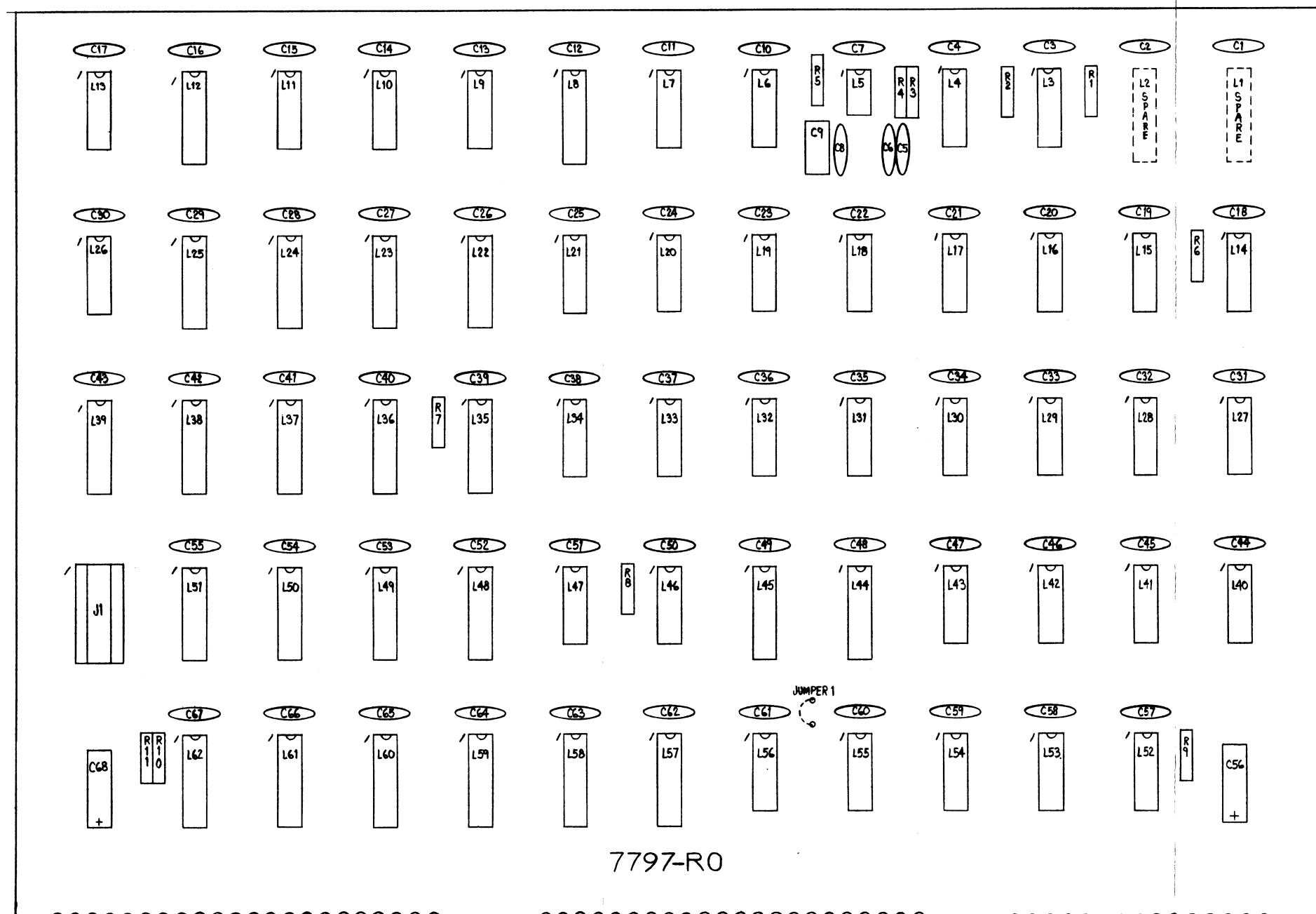

NO.	REV.	DATE	BY
REVISION			
SEE SHEET 4			

WANG LABORATORIES, INC. LOWELL, MASS. U.S.A.		BY DWN R. Blubinski	DATE 12-31-80	APPROVED BY E ENGR	DATE
MATERIAL		MODEL NO. 2200MVP/LVP		TITLE EXTENDED INSTRUCTION COUNTER	
FINISH		TOL. EX. AS NOTED XX ± FRAC ± XXX ± ANG. ± FINISH		210-7797	7797
SCALE 1/8" = 1"		SMT 3 OF 4		WANG PART NUMBER	REV.

11 10 9 8 7 6 5 4 3 2 1

THIS DRAWING AND THE DATA SHOWN THERE ON ARE THE CONFIDENTIAL PROPERTY OF, AND ARE PROPRIETARY TO, WANG LABORATORIES, INC. THIS DRAWING AND THE DATA SHOWN THEREON MAY NOT BE MADE PUBLIC WITHOUT THE WRITTEN CONSENT OF WANG LABORATORIES, INC. IF FOR ANY REASON THIS DRAWING IS PERMITTED BY WANG TO LEAVE THE PHYSICAL CUSTODY OF THE COMPANY, IT IS RETURNABLE UPON THE DEMAND OF WANG LABORATORIES, INC.

DO NOT SCALE

I.C. LOCATION	TYPE	W.L. PART NO.
L1,2	SPARE	---
L3,14,27	7474	376-0006
L4,10	7400	376-0002
L5	555	376-0126
L6,11,43	7432	376-0093
L7,15,53	7410	376-0003
L8,42	7442A	376-0008
L9	7427	376-0125
L13	7402	376-0016
L16,21	7408	376-0081
L17,52	7404	376-0010
L18	74S11	376-0237
L19,46,47	74564	376-0201
L20,30	74S10	376-0238
L22-25,35-38	74153	376-0048
L26,41	7420	376-0004
L28,29	7453	376-0057
L31	74S04	376-0197
L32,40,54	74S08	376-0200
L33	74S32	376-0205
L34,42	74S02	376-0199
L39,48-51	74191	376-0203
L44,45	74157	376-0082
L55,56	7493	376-0011
L57,58	74367	376-0176
L59-62	74161	376-0094

COMPONENT	TYPE	W.L. PART NO.
R1-3, 6-11	1K, 1/4W, 10%	330-3010
R4	2.2K, 1/4W, 10%	330-3022
R5	390Ω, 1/4W, 10%	330-2039
C1-4, 7, 10-55, 57-67	.047μf	300-1966
C5	.0033μf	300-1909
C6, 8	.01μf, 25V	300-1903
C9	1000pf, (M)	300-5006
C56, 68	15μf, 20V (T)	300-4022
J1	6 PIN I.C. SKT.	376-9005

MNEMONICS	COORD.	MNEMONICS	COORD.
B	1G7	T1	1C11
BRANCH	1G3	T3	1C11
CAO-11	2B-C1	T4	1B11
CI12-14	2A6	T5	1B11
CNTD	1A5	T7	1E11
DMP1	1G11	T8	1G6
ICCO-15	2A7-10	T12	1B11
LHPC	1C1	T16	1B11
LLPC	1D1	TAP	1D11
LOP	1F11	TSP	1D11
LPI	1C11	TPI	2C11
ICO-IC15	2A5	WPB	1D11
MARCLK	1C11	XOP	1A11
PECC	1A4	XPA	1D11
PECM	1B11		
PEDM	1F11		
PINC	1A4		
PDR	1G11		
R2-17	2G8-10		
R18, 20-22	1G6		
R/W	1A7		
RAO-5	2D1		
REF	2C11		
ROMS	2F1		
RESET	1F11		
REFCLK	2C11		
SB	1G8		
SR	1G5		
SO-7	2G6-7		
SWITCH	2F1		
SWITCH	2G2		

TYPE	I.C. LOCATION	SPARES
7400	L10	1
7402	L13	1
74S02	L34	1
	L42	2
7408	L21	1
74S08	L54	1
	L40	2
7410	L7	1
	L53	1
74S10	L30	2
	L20	1
74S11	L18	2
7432	L11	2
	L43	1
74S32	L33	3
7474	L27	1
74367	L58	1

NO.	REVISION	DATE	BY
1	ORIGINATED PER DIV. E1000 APP'D. MGR. 1-23-81	1-23-81	KBP

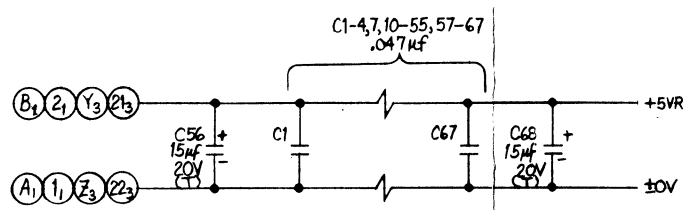
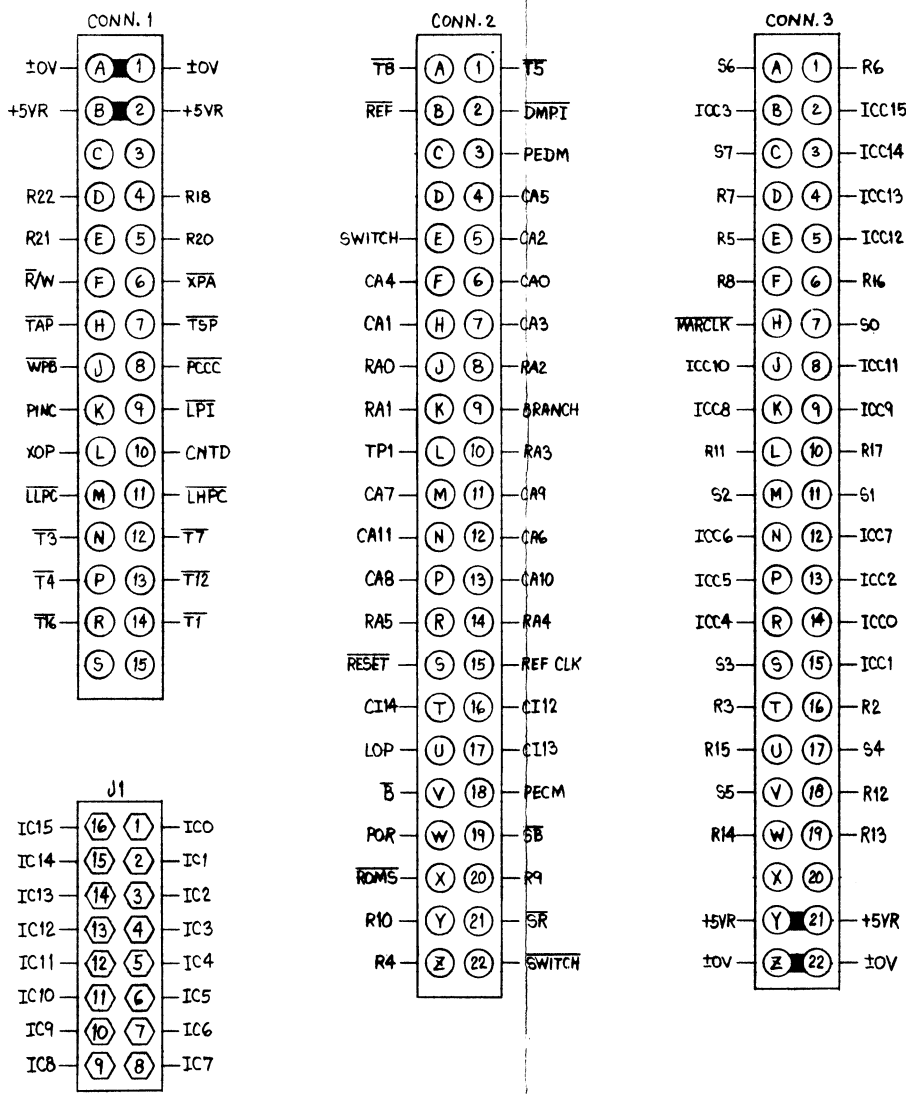

E-REV
0

WANG LABORATORIES, INC. LOWELL, MASS. U.S.A.		BY DWN R. Blahush	DATE 3-1-81	APPROVED BY E ENGR D. Dally	DATE 1-23-81
MATERIAL	MODEL NO. 2200MVP/LVP	TITLE EXTENDED INSTRUCTION COUNTER			
FINISH	TOL. AS NOTED XX ± XXX ±	210-7797	D	7797	0
SCALE 1/8" = 1"	SHEET 4 OF 4	WANG PART NUMBER	SIZE	DRAWING NUMBER	REV.

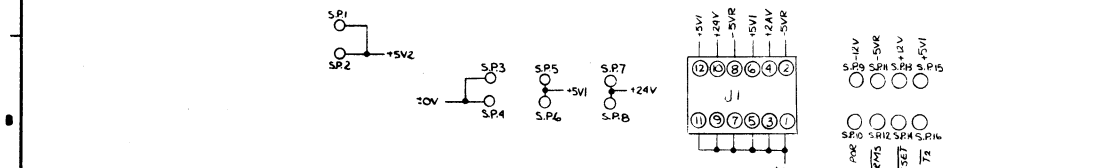
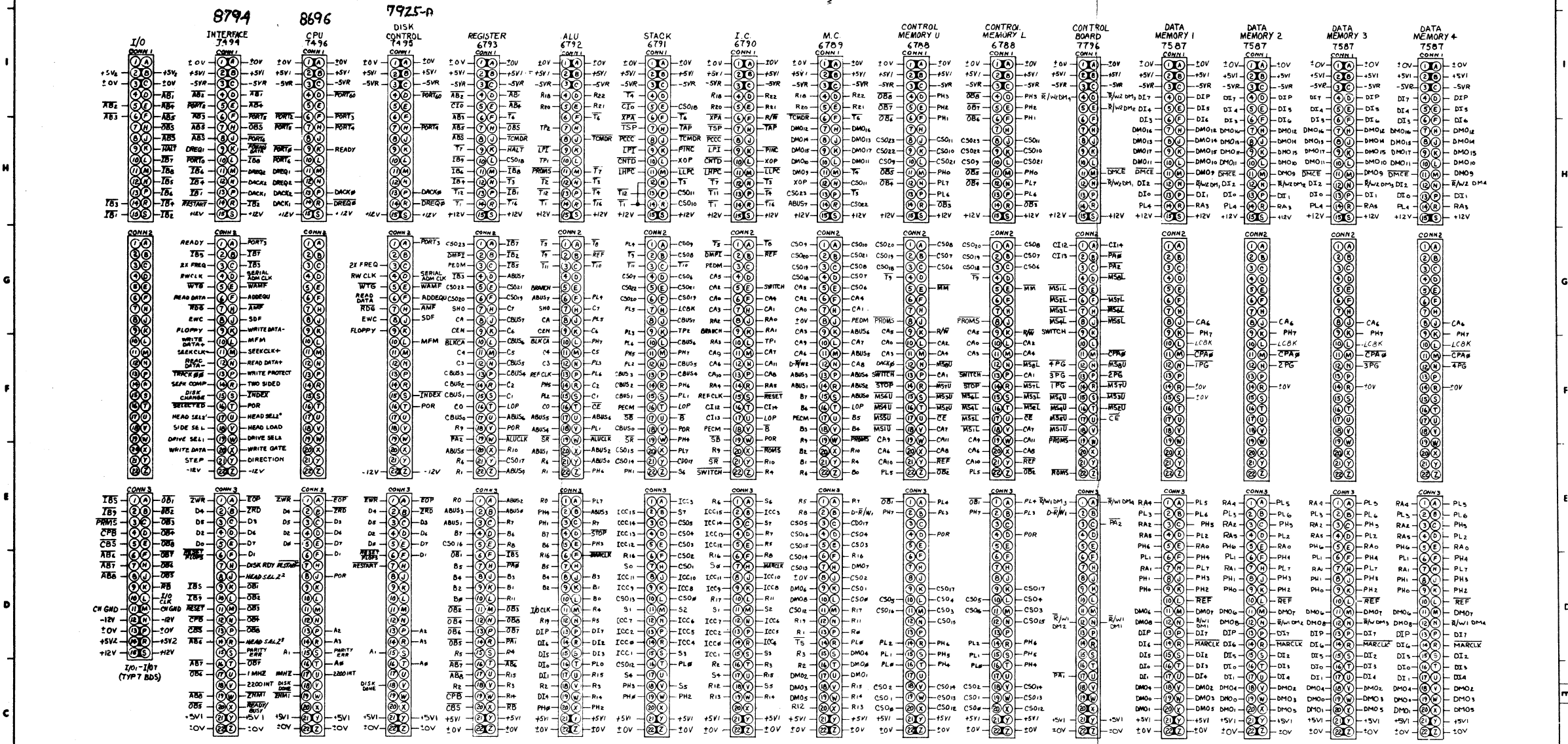
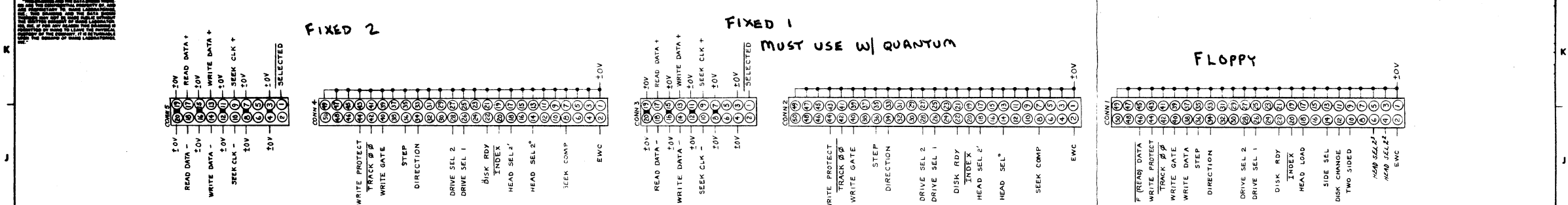

COMPONENT	TYPE	WL PART NO
J1	12 PIN HEADER	654-1172
J2-23, 53-59	30 PIN CONN	350-0011
J24-37	44 PIN CONN	350-0039
J38-52	44 PIN CONN	350-0021

WANG LABORATORIES, INC.		BY	DATE	APPROVED BY	DATE
MATERIAL	MODEL NO. LVP	DWN	3-11-81	E ENGR	
FINISH	TITLE	CHK		M ENGR	
	EXTENDED MEMORY MOTHERBOARD			MFG ENGR	
	210-7799				
	7799				

PRODUCT SERVICE NOTICE

DATE : 7/11/80

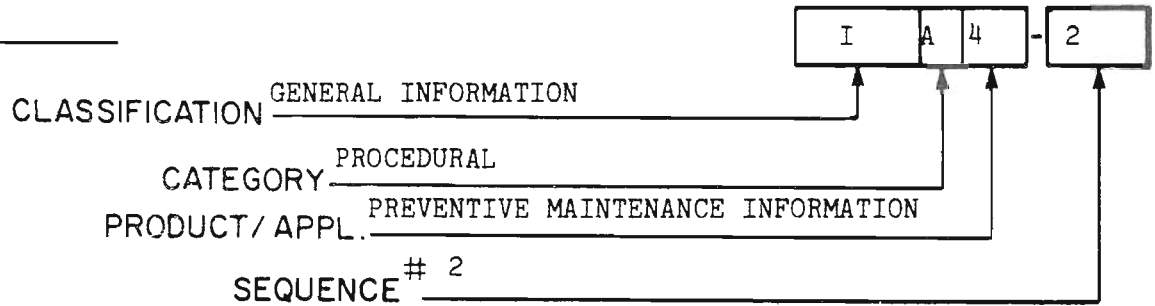

TITLE:

MODEL 2200LVP/SVP CPU PREVENTIVE MAINTENANCE

To ensure trouble-free operation, the 2200LVP/SVP must have periodic preventive maintenance, consisting of inspection, cleaning, and adjustments. The PM procedures are given in this PSN.

The following preventive maintenance routines should be performed once every six to twelve months. This preventive maintenance schedule assumes a clean operating environment and a normal operating time during the standard five-day, 40-hour weeks. A dusty environment or any substantial increase in system operating time will require that the preventive maintenance be scheduled at closer intervals. In addition, these preventive maintenance routines should be performed during each unscheduled service call.

1. Turn the CPU ac power switch OFF.
2. Check the unit cooling fan for proper operation.



I.A.4-2

3. Use a soft-bristle brush and a vacuum cleaner (WL #726-9518) to remove dust from the inside of the CPU.

4. Ensure that the 2200LVP/SVP is kept up-to-date by verifying and installing all required ECN's (ref: Mandatory Update Bulletin, CE #03-0085--I.B.0).

5. Turn the CPU ac power switch ON.

6. Check the CPU power supply voltages according to the procedure given in SECTION 11 of Model 2200LVP Maintenance Manual, IV.A.3.M, and in Addendum One to that same manual (SVP documentation). Adjust if necessary.

CAUTION:

Before making any adjustments, be certain that the measuring instruments are properly calibrated, and then test the item. Adjustments, particularly electrical adjustments, should be performed only when the parameter measured proves to be out of tolerance. Do not make electrical or mechanical adjustments indiscriminately.

7. Perform all preventive maintenance measures for the DSDD Diskette Drive (ref: documentation category III.A.11), and the Fixed-Disk Drive (ref: documentation category III.A.12).

8. Run the LVP/SVP diagnostics referenced in SECTION 9 of Model 2200LVP Maintenance Manual, IV.A.3.M, and in Addendum One to that same manual, as needed, to confirm proper operation of the CPU circuitry.

9. Use a mild detergent and a soft cloth or sponge to remove dirt and grime from the CPU cabinetry. Do not use abrasive or corrosive chemicals.

Handwritten:
 Bud Kumbal
 Keith Costen
 Mark McCarty
 CJK ✓

PRODUCT SERVICE NOTICE

DATE: 1/15/82

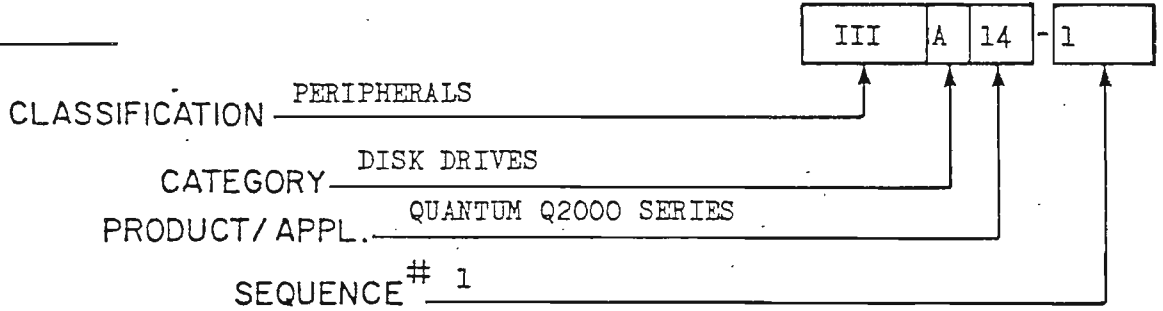

TITLE:

2200 LVPC QUANTUM DISK DRIVE INTERFACE INSTALLATION

Large watermark: ADVANCE COPY

SCOPE

This PSN describes the installation of the Quantum Disk Drive Interface into a 2200 LVPC. The 2200 LVPC is a 2200 LVP upgraded by installation of Memory Option C to increase its maximum control memory from 32K to 64K and its data memory from 256K to 512K. The Quantum Disk Drive Interface will allow the 2200 LVPC to communicate with the following drives:

<u>Quantum Drive</u>	<u>Storage</u>	<u>AC Req.</u>	<u>Part Number</u>
Q2020	20 mBytes	60 Hz	278-4024
Q2020	20 mBytes	50 Hz	278-4024-1
Q2040	40 mBytes	60 Hz	278-4025
Q2040	40 mBytes	50 Hz	278-4025-1

RELATED DOCUMENTATION

- a. PSN 729-1028 (class code IV.A.3-8) describes the installation of Memory Option C to upgrade a 2200 LVP into a 2200LVPC.
- b. The Quantum Q2000-Series OEM vendor manual provides installation, operation, and maintenance information for the Quantum Disk Drive interfaced to the 2200 LVPC.

CHESTER KASPRZAK
 RDB 3105



PARTS REQUIRED

The only part required for implementation of the Quantum LVP Interface is one Fixed/Floppy Interface PCB (P/N 210-8794).

TOOLS AND TEST EQUIPMENT REQUIRED

No special tools or test equipment are required to install this option. The standard items provided in the Wang CE tool Kit will suffice.

INSTALLATION PROCEDURE

- a. At the 2200 LVPC, set the power ON/OFF switch to OFF. Remove the AC power cord from the wall outlet.
- b. Remove the top cover of the 2200 LVPC cabinet by first removing the two screws from the rear-underneath sides of the top cover using a 5/16-inch nut driver (99-10). Lift the top cover out of the two snap locks and set it aside.
- c. Remove the 210-8694 PCB from the LVPC card cage. The 210-8694 PCB is located next to the I/O connectors (see figure 1).
- d. Insert the new 210-8794 Fixed/Floppy Interface PCB into the slot closest to the I/O connectors.
- e. Connect the Quantum Disk Drive to the existing connectors on the 2200 LVPC cable harness. QUANTUM DISK DRIVE MUST BE CABLED TO CONN 2+3, FIXED 1, & NOT CONN 4+5, FIXED 2.
- f. Install the top cover of the 2200 LVPC cabinet.
- g. Connect the ac power cable to the wall outlet and set the ac power ON/OFF switch to ON.

DISPOSITION OF 210-8694 PCB

Return the 210-8694 PCB to the Branch level stock area.

QUANTUM DRIVE BELT - 726-2602

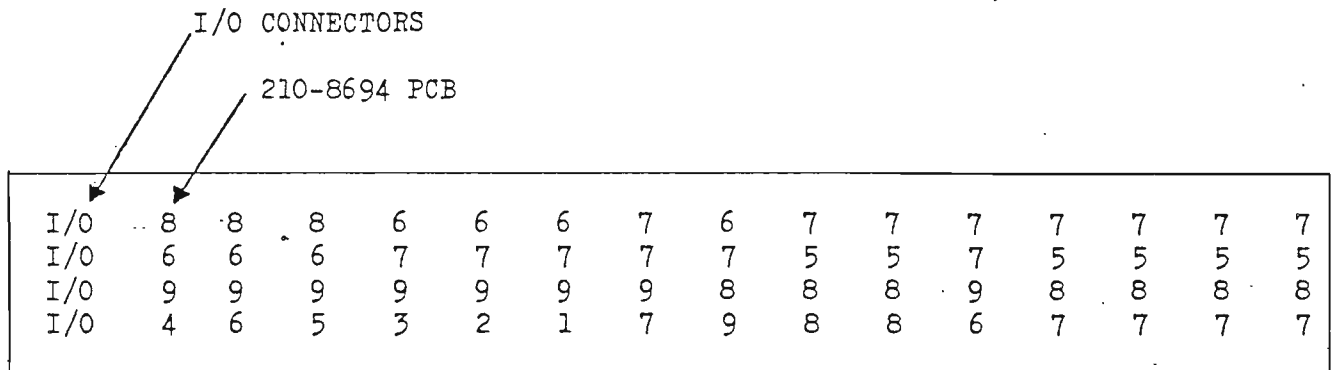

Figure 1. 2200 LVPC Motherboard Layout

PRODUCT SERVICE NOTICE

DATE : 7/11/80

CLASSIFICATION 2200 SYSTEMS

CATEGORY INTERFACE

PRODUCT/APPL. I/O CONTROLLERS

SEQUENCE # 1

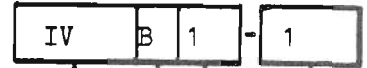

TITLE:

MODEL 2236MXD (WL #177-3236-1) MULTIPLEXER/CONTROLLER

This PSN contains information concerning the Model 2236MXD Multiplexer/Controller board. The information is divided into the following categories.

1. GENERAL DESCRIPTION
2. PROM LOADING
3. SWITCH SETTINGS
4. INSTALLATION
5. SYSTEM INTERCONNECTION
6. DIAGNOSTICS
7. TROUBLESHOOTING
8. HARDWARE THEORY OF OPERATION

Other documentation categories referenced in this PSN are:

CPU Power Supply Voltage Adjustments -- IV.A.3
System Interconnection -- III.D.1, IV.A.3, and IV.B.1
Diagnostics -- IV.A.3 (MVP), and IV.C.1 (LVP)
Theory of Operation -- III.D.1

1. GENERAL DESCRIPTION

The Model 2236MXD Multiplexer/Controller is the standard terminal input/output interface for the 2200LVP/MVP product line. The 2236MXD controller is capable of supporting up to four 2236D/DE terminals. As of the date of this PSN, one 2236MXD controller can be installed in an LVP system, and up to three 2236MXD controllers can be installed in an MVP system with Operating System Release 1.9 (WL #701-2294K) or higher.

The 2236MXD controller handles I/O operations between a 2236D/DE terminal and CPU, and acts as a buffer for data transmitted between the terminal and the LVP/MVP CPU. With the controller managing these tasks, the CPU is free--under the control of the Operating System--to execute a program and to monitor the operations of other system peripherals. Communication between the 2236MXD controller and each 2236D/DE terminal is asynchronous, full-duplex, with line speeds selectable from 300 to 19.2K baud. Specifically, communication speeds of 300, 600, 1200, 2400, 4800, 9600, and 19.2K baud are supported by the 2236MXD controller. A terminal can be connected to a controller locally at distances of up to 2000 feet via direct cabling, or the terminal can be located in more remote locations using a telecommunications link. Such flexibility is possible, due to the fact that 2236MXD controllers and 2236D/DE terminals are compatible to the EIA RS-232-C and CCITT V.24 standards for telecommunications.

The 2236MXD (WL #177-3236-1) consists of two circuit boards (occupying only one CPU I/O slot): a WL #210-7290-1A motherboard containing the terminal interface electronics, and a WL #210-7291-D (or a newer version WL #210-7591-A) daughterboard containing the 8080-based microprocessor electronics.

2. PROM LOADING

The firmware for the 2236MXD is contained on the WL #210-7291-D (or WL #210-7591-A) board and consists of the following four PROM's (ref: FIGURE 1):

<u>PROM #</u>	<u>WL #</u>	<u>210-7291-D</u> <u>LOCATION</u>	<u>210-7591-A</u> <u>LOCATION</u>
1	378-2140R6	L32	L27
2	378-2141R6	L17	L26
3	378-2142R6	L16	L25
4	378-2143R6	L15	L24

NOTE: PROM revisions should be R6 or above.

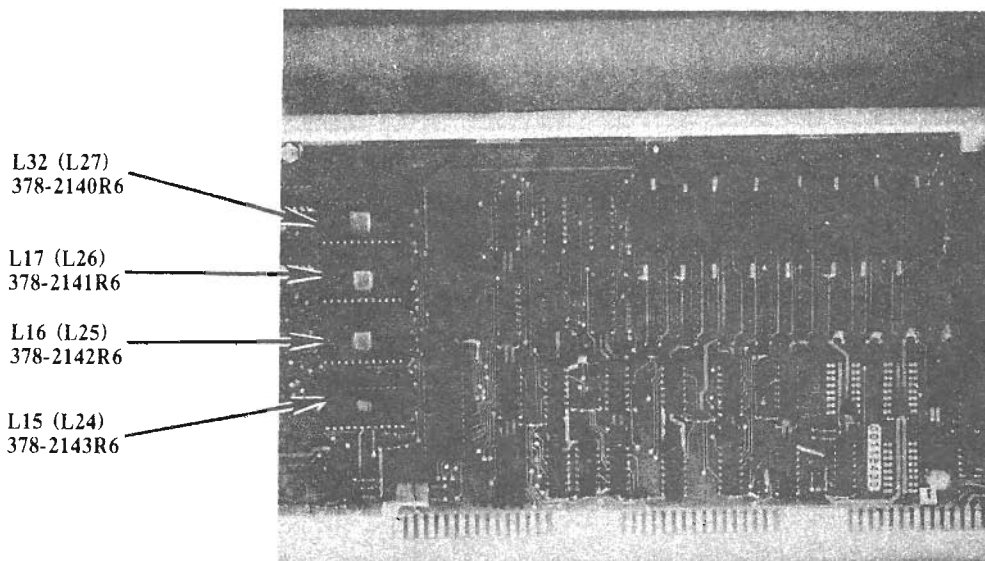

**FIGURE 1 WL NO. 210-7291-D (210-7591-A) DAUGHTERBOARD
FOR 2236MXD I/OCONTROLLER**

3. SWITCH SETTINGS

The 2236MXD address is set by means of a five-section switchbank (SW1) located on the WL #210-7290-1A board (ref: FIGURE 2). For systems with a single 2236MXD, set the controller address switches to HEX(00); that is, all five switches in the bank must be OFF. In systems using two 2236MXD controllers, set the address switches of the primary controller (the one with the "system console" connected to channel #1) to HEX(00)--all switches OFF. Set the address switches of the other controller to HEX(40)--switch #1 is ON; all others are OFF. If a third 2236MXD is used, set the address switches of that controller to HEX(80)--switch #2 is ON; all others OFF.

DEVICE ADDRESS	SWITCH SETTINGS*				
	S-1	S-2	S-3	S-4	S-5
HEX(00)	0	0	0	0	0
HEX(40)	1	0	0	0	0
HEX(80)	0	1	0	0	0

* 0 = OFF; 1 = ON.

Note that the physical device address set on the controller is not the address specified in a program for access to the 2236D/DE terminal CRT, keyboard, or local printer. The programmable device addresses for all terminals are: 005 for a CRT; 001 for a keyboard; and 204 for a local printer. The Operating System translates these programmable addresses into the appropriate physical controller addresses.

For baud rate selection, there are three, 8-section switchbanks (SW2-SW4) located on the WL #210-7290-1A board (ref: FIGURE 2). These switches comprise four groups of six switches each, with each group corresponding to a channel. The switches in each group are labeled for the specific baud rates (ref: FIGURE 3). Only one switch in any group of six may be ON at any one time. If a terminal is not attached to a channel, the switch settings for that channel are irrelevant. A 2236D/DE terminal and its associated 2236MXD I/O port must have identical baud rate selections. Any local or remote modems must also be set to the same baud rate as the terminal and controller.

NOTE:

The 4800 switch is used for both 4800 and 19.2K baud.
For these rates, the selected rate depends on the
position of jumper A13, located between IC's L18 and
L19 (ref: FIGURE 3).

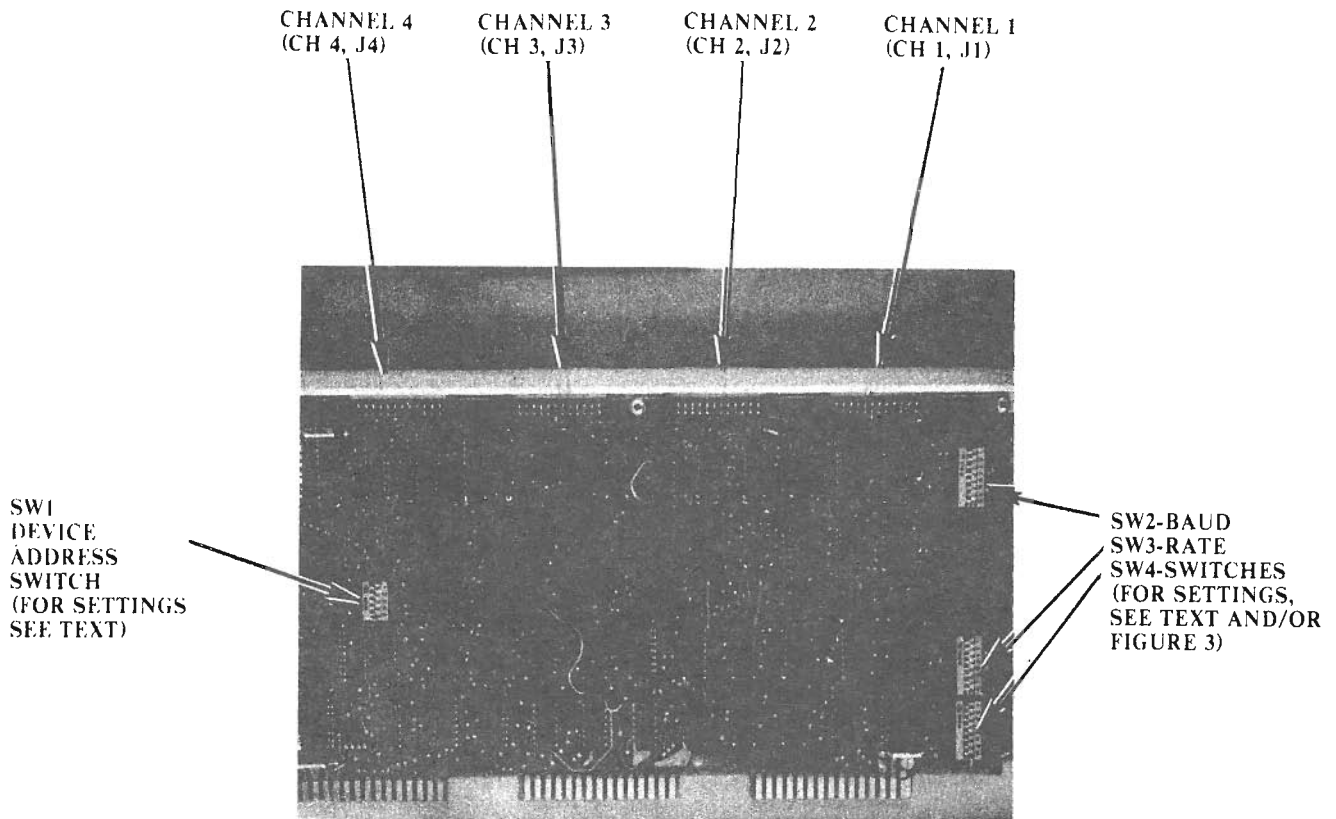

**FIGURE 2 WL NO. 210-7290-1A MOTHERBOARD
FOR 2236MXD I/O CONTROLLER**

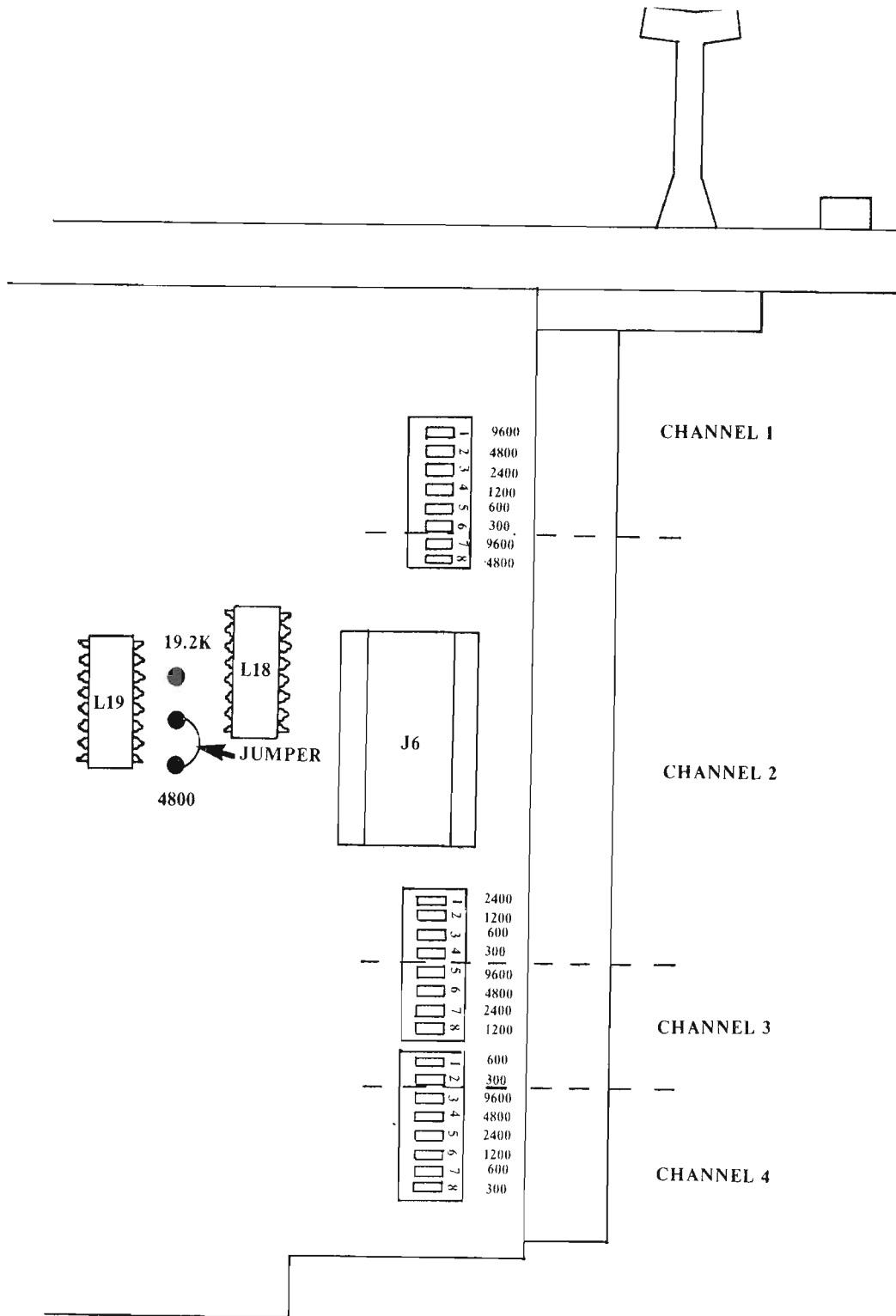

FIGURE 3 BAUD RATE SWITCH IDENTIFICATION

4. INSTALLATION

The 2236MXD can be installed in any available I/O slot in the 2200LVP/MVP CPU. Be certain to turn the CPU power off before installing the controller. Prior to inserting the board in any unit, ensure that all switches are set correctly (see Section 3). Also check to see that the fingerboard connectors are clean.

If additional 2236MXD controllers are being added to a system (upgrading the system), be certain to recheck and adjust, if necessary, the CPU power supply voltages after the boards have been installed. Refer to documentation category IV.A.3 for CPU voltage adjustment procedures.

5. SYSTEM INTERCONNECTION

Any combination of local, extended local, and remote connection may be used. However, the 2236D/DE terminal connected to channel #1 of the first MXD controller (device address HEX(00)) should be positioned relatively close to the CPU because that terminal acts as the "system console" for "Master Initialization" whenever the system is powered up. Allowable connection specifications (distance and baud rate) for the terminal relative to the CPU (and MXD controller) are as follows:

- a) LOCAL - for distances up to 25 ft (7.6 m) transmission rates of 19.2K baud are available with four-wire direct connection, using a Wang-supplied cable. (This is the standard configuration).
- b) EXTENDED LOCAL - for distances from 25 ft to 2000 ft (610 m) optional cables in up to 100 ft (30.5 m) increments provide extended local direct connection at speeds of up to 19.2K baud.
- c) REMOTE - for distances greater than 2000 ft (610 m) and line speeds up to 19.2K baud, asynchronous full-duplex, RS232C-compatible modems must be used to provide the communication link.

Distances up to 5 miles (8 km): short-haul modems using private (point-to-point) 4-wire connection between modems may be employed.

Distances exceeding 5 miles (8 km): telephone lines, capable of handling many users, provide the dial-up connection between two modems.

Optional cables for modem connections to Wang equipment are available in 12 ft (3.7 m), 25 ft (7.6 m), and 50 ft (15.2 m) lengths.

Refer to PSN IV.B.1-4 for I/O cable part numbers and connection information. Also refer to documentation categories III.D.1, and IV.A.3 for additional information concerning system interconnection.

6. DIAGNOSTICS

There is no special diagnostic for testing the 2236MXD controller. The BASIC-2 Language Diagnostic should be used to check out the MXD. Refer to documentation category IV.A.3 for diagnostic operating procedures on an MVP system, or to documentation category IV.C.1 for diagnostic operating procedures on an LVP system.

7. TROUBLESHOOTING

To determine whether a transmission failure is due to the 2236MXD or a terminal that is connected to it, the Customer Engineer should swap cables (at the MXD) between a working channel and the malfunctioning channel. If the problem remains with the same MXD channel, the 2236MXD is bad; if the problem moves with the suspected terminal to the different MXD channel, the terminal is bad.

8. HARDWARE THEORY OF OPERATION

Refer to Module Repair Guide No. 3.2 (III.D.1) for general and detailed theory of operation.

PRODUCT SERVICE NOTICE

DATE : 7/11/80

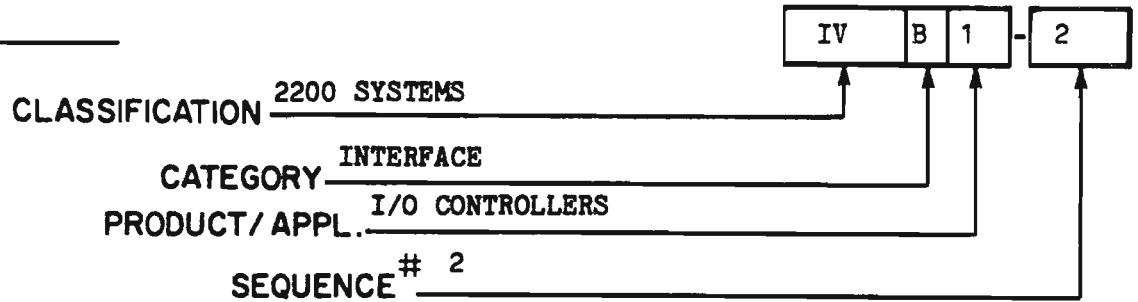

TITLE:

MODEL 22C32 (WL #212-3012) TRIPLE CONTROLLER

This PSN contains information concerning the Model 22C32 Triple Controller. The information is divided into the following categories.

1. GENERAL DESCRIPTION
2. SWITCH SETTINGS
3. PROM LOADING
4. INSTALLATION
5. SYSTEM INTERCONNECTION
6. DIAGNOSTICS
7. HARDWARE THEORY OF OPERATION

Other documentation categories referenced in this PSN are:

CPU Power Supply Voltage Adjustments -- IV.A.3
System Interconnection -- III.D.1, IV.A.3, and IV.B.1
Diagnostics -- IV.A.3 (VP/MVP), and IV.C.1 (LVP)
Theory of Operation -- III.D.1



1. GENERAL DESCRIPTION

The Model 22C32 Triple Controller is an I/O option available for the 2200VP/LVP/MVP product line, and is capable of supporting a 2236D/DE terminal, any 2200 series disk drive, and a printer.

The disk and printer portions of the 22C32 controller logic are similar to existing disk and printer interface controllers (22C12 and 22C13 disk controllers excluded).

The terminal portion of the 22C32 controller logic handles I/O operations between a 2236D/DE terminal and CPU, and acts as a buffer for data transmitted between the terminal and the VP/LVP/MVP CPU. With the controller managing these tasks, the CPU is free--under the control of the Operating System--to execute a program and to monitor the operations of other system peripherals. Communication between the terminal and the controller is asynchronous, full-duplex, with a fixed baud rate of 19.2K. The terminal can be connected to the controller locally at distances of up to 2000 feet via direct cabling, or the terminal can be located in more remote locations using a telecommunications link. Such flexibility is possible, due to the fact that 22C32 controller and 2236D/DE terminals are compatible to the EIA RS-232-C and CCITT V.24 standards for telecommunications.

Because the terminal portion of the 22C32 can operate along with one (2200LVP application), two or three 2236MXD multiplexers/controllers (2200MVP application), which support up to four 2236D/DE terminals each, an LVP system with a 22C32 can support a maximum of five 2236DE terminals, and an MVP system with a 22C32 can support a maximum of thirteen 2236D/DE terminals. (See the following chart.)

A VP system with a 22C32 can support one 2236D/DE terminal (replacing the 2226 console).

NOTE:

Only one 22C32 can be installed in any system.

PRESENT ALLOWABLE SYSTEM CONFIGURATIONS

2200 CPU	<u>VP</u>	<u>LVP</u>	<u>MVP</u>
No. of 22C32 Controllers	1	1	1
No. of 2236MXD Controllers	0	1	1, 2, or 3
No. of Terminals in System	1	5	5, 9, or 13

The 22C32 triple controller (WL #212-3012) consists of two circuit boards (occupying only one CPU I/O slot): a WL #210-7515 motherboard containing the printer and disk interface electronics, and a WL #210-7516A daughterboard containing the Z80-based 2236D/DE interface electronics.

2. SWITCH SETTINGS

The address of the terminal portion of the 22C32 is selected by means of a five-section switchbank (SW1) located on the WL #210-7515 board (ref: FIGURE 1). The chart below shows the proper switch settings for one, five, nine, and thirteen-terminal systems.

<u>NUMBER OF TERMINALS</u>	<u>SWITCH SETTINGS*</u>					<u>DEVICE ADDRESS</u>
	<u>S-5</u>	<u>S-4</u>	<u>S-3</u>	<u>S-2</u>	<u>S-1</u>	
One	0	0	0	0	1	HEX(00)
Five**	0	1	0	0	1	HEX(40)
Nine***	1	0	0	0	1	HEX(80)
Thirteen****	1	1	0	0	1	HEX(C0)

* 0 = OFF; 1 = ON. S-1 is the terminal enable switch--it is always set ON; S-2 through S-5 are the terminal device address switches.

** One 2236MXD and one 22C32 (LVP and MVP systems)

*** Two 2236MXD's and one 22C32 (MVP system only)

**** Three 2236MXD's and one 22C32 (MVP system only)

Note that the physical terminal address set on the controller is not the address specified in a program for access to the 2236D/DE terminal CRT, keyboard, or local printer. The programmable device addresses for all terminals are: 005 for a CRT; 001 for a keyboard; and 204 for a local printer. The Operating System translates these programmable addresses into the appropriate physical terminal addresses.

IV.B.1-2

Both the printer and disk addresses are switch-selectable by means of two 8-section switchbanks (SW2 and SW3) located on the WL #210-7515 board (ref: FIGURE 1). SW2 selects the printer address (normally HEX 215 or 216) and SW3 selects the disk address (normally HEX 310, 320 or 330). Refer to PSN IV.B.1-3 for the proper setting of these device address switches.

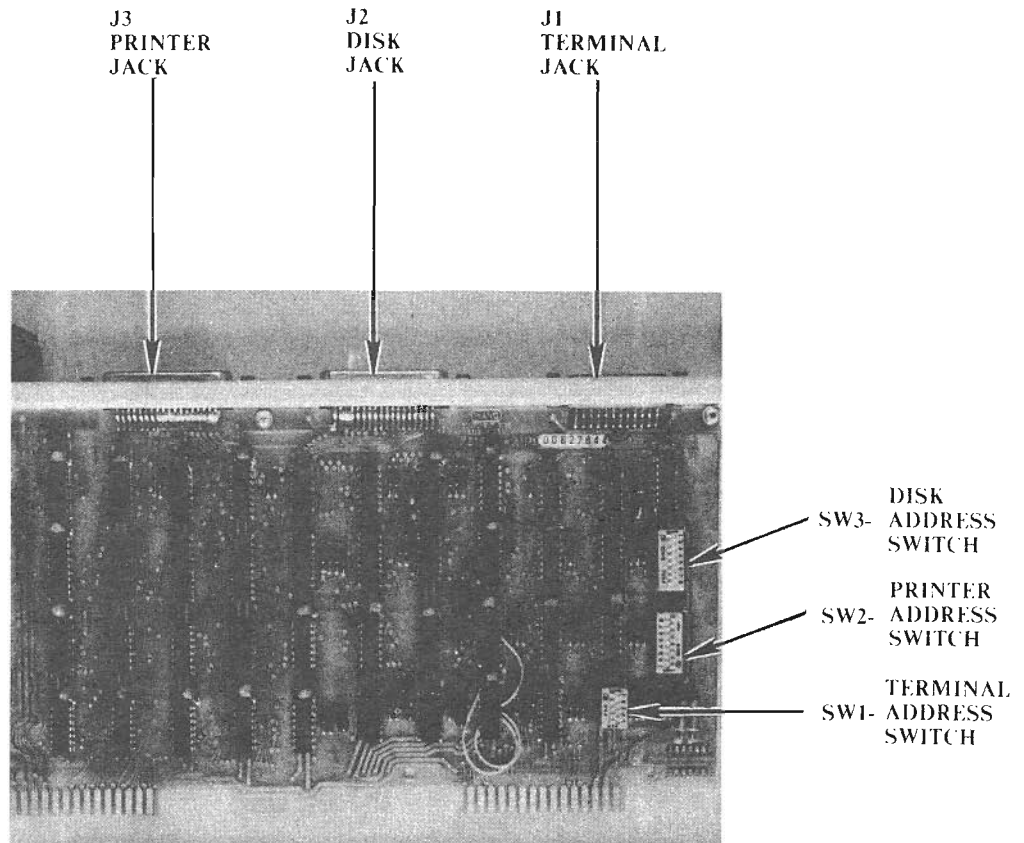

**FIGURE 1 WL NO. 210-7515 MOTHERBOARD
FOR 22C32 I/O CONTROLLER**

3. PROM LOADING

The firmware for the terminal portion of the 22C32 is contained on the WL #210-7156A board and consists of two PROM's: #1 (WL #378-4092) in location L17, and #2 (WL #378-4093) in location L18 (ref: FIGURE 2).

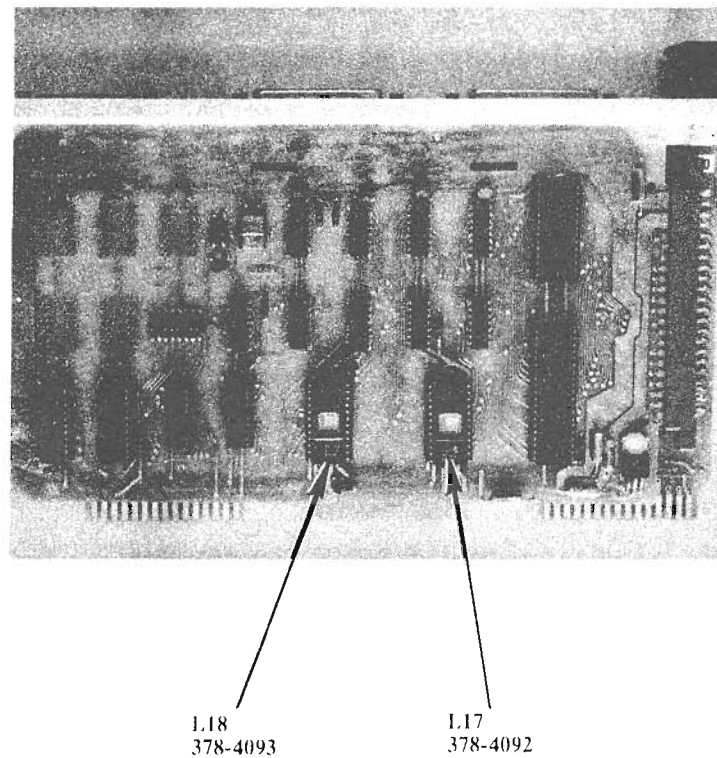

**FIGURE 2 WL NO. 210-7156-A DAUGHTERBOARD
FOR 22C32 I/O CONTROLLER**

4. INSTALLATION

The 22C32 can be installed in any available I/O slot in the 2200VP/LVP/MVP CPU. Be certain to turn the CPU power off before installing the controller. Prior to inserting the board in any unit, ensure that all switches are set correctly (see Section 2).

If the 22C32 controller is being added to an existing system, be certain to recheck and adjust, if necessary, the CPU power supply voltages after the board has been installed. Refer to documentation category IV.A.3 for CPU voltage adjustment procedures.

5. SYSTEM INTERCONNECTION

Terminal Portion

Any combination of local, extended local, and remote connection may be used. Allowable connection specifications (distance and baud rate) for the terminal relative to the CPU (and 22C32 controller) are as follows:

- a) LOCAL - for distances up to 25 ft (7.6 m) transmission rate of 19.2K baud is available with four-wire direct connection, using a Wang-supplied cable. (This is the standard configuration).
- b) EXTENDED LOCAL - for distances from 25 ft to 2000 ft (610 m) optional cables in up to 100 ft (30.5 m) increments provide extended local direct connection at a speed of 19.2K baud.
- c) REMOTE - for distances greater than 2000 ft (610 m) and a line speed of 19.2K baud, asynchronous full-duplex, RS232C-compatible modems must be used to provide the communication link.

Distances up to 5 miles (8 km): short-haul modems using private (point-to-point) 4-wire connection between modems may be employed.

Distances exceeding 5 miles (8 km): telephone lines, capable of handling many users, provide the dial-up connection between two modems.

Optional cables for modem connections to Wang equipment are available in 12 ft (3.7 m), 25 ft (7.6 m), and 50 ft (15.2 m) lengths.

Refer to PSN IV.B.1-4 and documentation categories III.D.1, and IV.A.3 for additional information such as I/O cable part numbers and connection information.

Disk and Printer Portions

Refer to PSN IV.B.1-4 and the appropriate disk/printer documentation category for information concerning system interconnection.

6. DIAGNOSTICS

Terminal Portion

There is no special diagnostic for testing the terminal portion of the 22C32 controller. The BASIC-2 Language Diagnostic should be used to check out the 22C32. Refer to documentation category IV.A.3 for diagnostic operating procedures on an VP/MVP system, or to documentation category IV.C.1 for diagnostic operating procedures on an LVP system.

Disk and Printer Portions

Refer to the appropriate disk/printer documentation category for diagnostic operating procedures.

7. HARDWARE THEORY OF OPERATION

Refer to Module Repair Guide No. 3.2 (III.D.1) for general and detailed theory of operation for the terminal portion of the controller.

Bill H, Phil B Fy - / Jan C

WANG FIELD CHANGE ORDER

FCO NO.
1045

Equipment Affected VP, LVP, MVPA, MVPC

Class Problem Only FCO Kit # 728-0063 Page 1 of 7

Org. Code 4103 (IV.A.3) FCO Doc. # 729-1325 Approval Date: DEC 28 1983

Est. Install. Time 20 Minutes Ref. ECO # 27336

1. REASON FOR CHANGE

A thin fan is required in the I/O section of the chassis to accomodate the increased length of the MXE board.

2. DESCRIPTION OF CHANGE

The fan in the I/O section of the chassis is replaced by a thinner fan (400-1029).

3. DOCUMENTATION AFFECTED

N/A

4. PREREQUISITE (S)

This change is required only in units with the longer MXE board.

5. INSTALLATION PROCEDURE

Determine the correct instruction set needed to complete the fan installation by checking the list below:

- Step A Use for VP models
- Step B Use for MVP models
- Step C Use for LVP models
- Steps D-E All models

Tech Ops <i>12/27/83</i> <i>Michael Wiley</i>	Logistics <i>12-28-83</i> <i>Karen Falumbo</i>	Originator <i>12/27/83</i> <i>Mary Kealey</i>	FCO Coordinator <i>John Prosko 12/28/83</i>
--	---	--	--

A. Refer to Figure 1. Replace the fan in the I/O section of the VP chassis as follows:

1. Power down unit. Remove AC power plug from wall outlet.
2. Remove the I/O controllers from the motherboard and CPU cards as needed.
3. Disconnect fan cord from old fan (400-1009).
4. Remove the old fan from the chassis. Save the four lock nuts to secure the new fan to the chassis in Item 5 below.
5. Install the new fan (400-1029) on the side panel of the chassis. Hold the fan against the inside of the side panel. When properly placed, the air flow indicator on the fan is at the top of the unit. Secure the fan using four new screws (650-3327) and the four lock nuts saved from Item 4 above.

NOTE: The air flow from the fan blows out of the chassis.

6. Connect the fan cord to the fan.
7. Replace the I/O controllers in the unit and CPU cards if removed. Proceed to Step D below.

B. Refer to Figure 2. Replace the fan in the I/O section of the MVP chassis as follows:

1. Power down unit. Remove AC power plug from wall outlet.
2. Remove the I/O controllers from the motherboard and CPU cards as needed.
3. Disconnect fan cord from old fan.
4. Remove the old fan from the chassis. Save the four lock nuts to secure the new fan in Item 5 below.
5. Install the new fan (400-1029) on the side panel of the chassis. Hold the fan against the inside of the side panel. When properly placed, the air flow indicator on the fan is at the top of the unit. Secure the fan using four new screws (650-3169) and the four lock nuts saved from Item 4 above.

NOTE: The airflow from the fan blows out of the chassis.

6. Connect the fan cord to the new fan.
7. Replace the I/O controllers and CPU cards if removed. Proceed to Step D below.

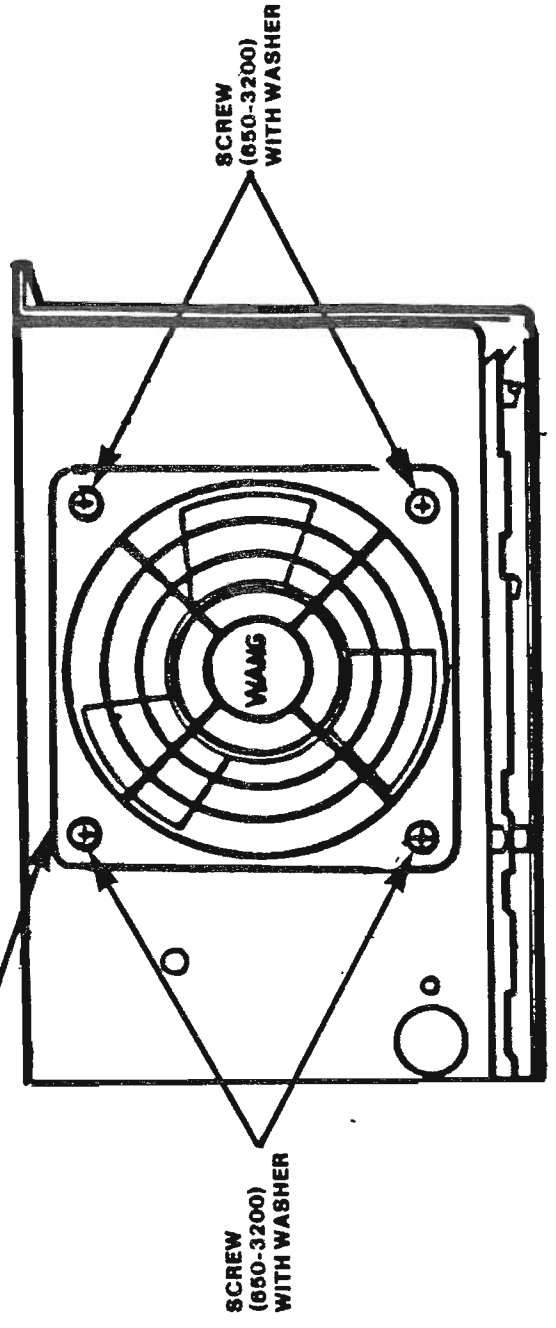
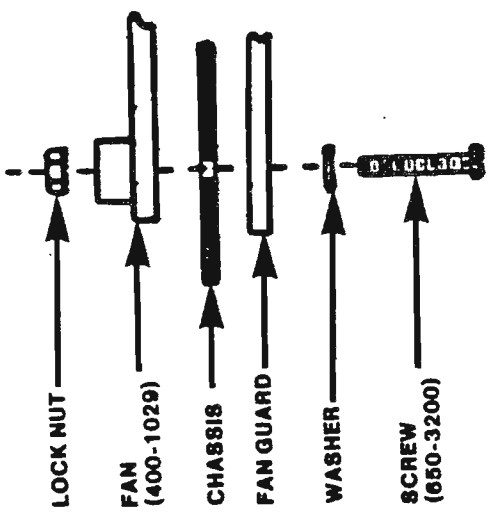
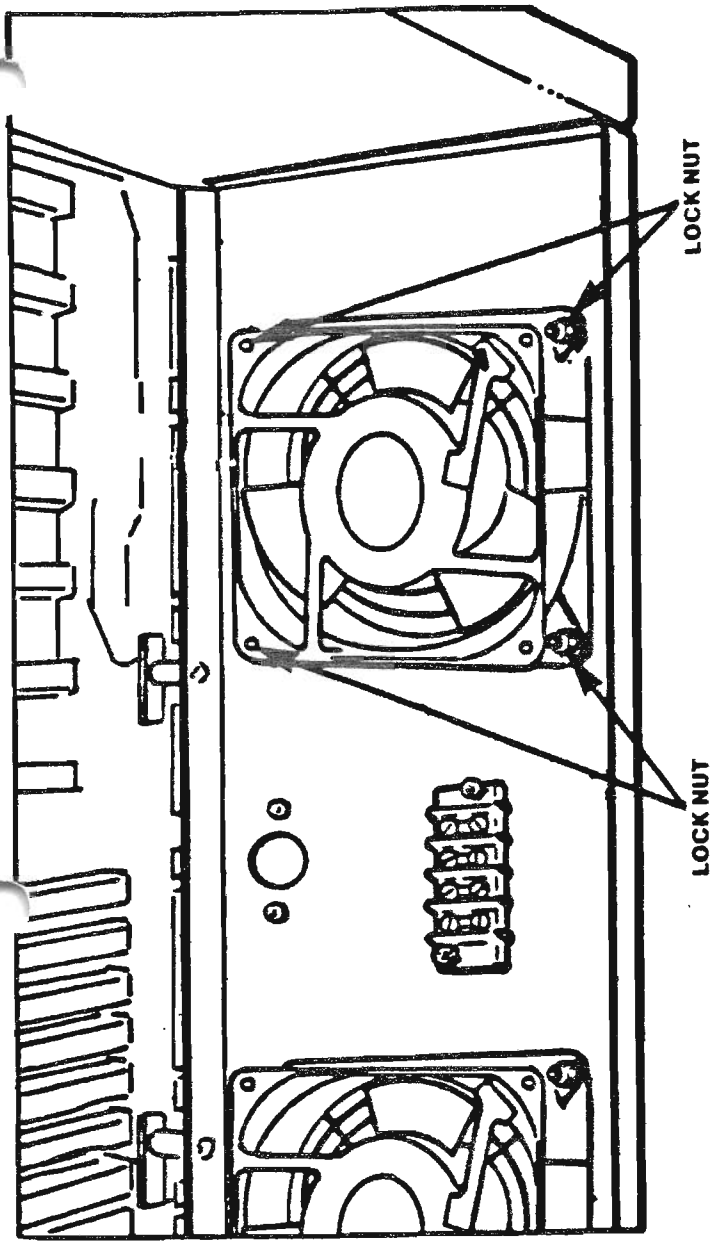

FIGURE 3 LVP FAN INSTALLATION

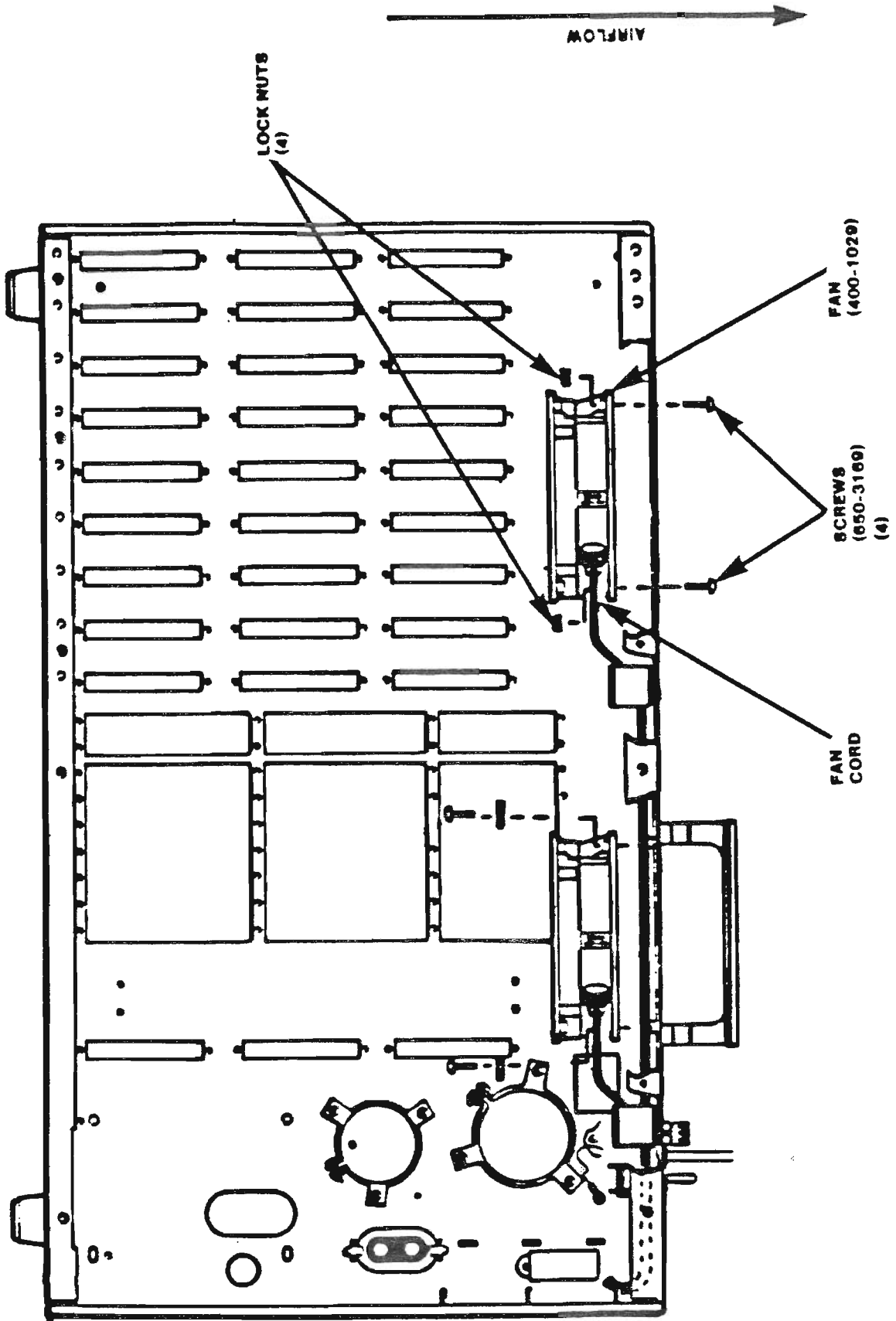

FIGURE 2 MVP FAN INSTALLATION

6. CHECK-OUT PROCEDURE

- A. Power up unit. Observe normal operation of the fan. Air flow blows from the inside to the outside of the chassis.
- B. Run the appropriate Diagnostic or System Exerciser listed below:

<u>System</u>	<u>Part #</u>	<u>Titles</u>	<u>Rev #</u>
VP	702-0138A	2200 CPU Diagnostics	11B4
MVP	702-0138A	2200 CPU Diagnostics	11B4
LVP	732-0002B	LVP/SVP System Exerciser	61B4

7. FCO KIT PARTS LISTING

KIT #728-0063

<u>Item</u>	<u>Qty</u>	<u>Item Description</u>
729-1325	1	FCO Document 1045
400-1029	1	Fan, Tube Axial
650-3327	4	Screw
650-3169	4	Screw
650-3200	4	Screw

8. FCO KIT AVAILABILITY DATE

FCO Kit# 728-0063 will be available January 9, 1984. To obtain the kit, place a routine order through the Logistics Order Processing system.

9. REMOVED PARTS DISPOSITION

Discard the removed fan and unused screws.

10. MISCELLANEOUS

This FCO does not apply to 2200 LVP Short Card Cage (with 3 I/O slots), 279-0572-TW, because the longer MXE board is not an option in this unit.

WANG

FIELD CHANGE ORDER

FCO NO.
1035

Equipment Affected 2236 MXD I/O Controller (2200 LVP, 2200 MVP)
 Class Problem Only FCO Kit# 728-0046 Page 1 of 4
 Org. Code VI.B.1 (4201) FCO Doc. # 729-1297 Approval Date: **MAY 23 1983**
 Est. Install. Time 30 Minutes Ref. ECO # 26937

1. REASON FOR CHANGE

To prevent intermittent system hangups.

2. DESCRIPTION OF CHANGE

Two capacitors are added to 210-7591 PCB of the 2236 MXD I/O controller.

3. DOCUMENTATION AFFECTED

N/A

4. PREREQUISITE (S)

N/A

Boston

WANG LABS INC. RDB 31 26
 BURLINGTON, MA (Qty 1)
 ATTN: Branch Manager, C.E.

5. INSTALLATION PROCEDURE

- A. Ensure power is off.
- B. Remove 2236 MXD I/O controller from 2200 system.
- C. Refer to Figure 1. Solder a 390 pf cap (300-1390) from L6 pin 13 to ground at L6 pin 7 on 210-7591-A PCB assembly.
- D. Add a 30 uf cap (300-3009) from Q2 pin 2 to ground on 210-7591-A PCB assembly.
 - 1. Solder the negative lead of the 30 uf cap (300-3009) to the etch leading to Q2 pin 2 as shown in Figure 1.
 - 2. Solder the positive lead of the 30 uf cap (300-3009) to the negative lead of C4 and to the etch leading to same as shown in Figure 1.
- E. Place E-Rev 1 sticker on 210-7591-A PCB assembly.

Tech Ops <i>Killes Curran</i> 5/20/83	Logistics 5/20/83 <i>Kevin Sanders</i>	Originator <i>Mary Keedy</i> 5/20/83	FCO Coordinator <i>John Prorby</i> 5/20/83
---	--	---	---

- F. Replace 2236 MXD I/O controller in 2200 system.
- G. Perform Check-out procedure described below in Section 6.
- H. Document installation of FCO by completing a Call Report or Activity Report.

6. CHECK-OUT PROCEDURE

Run the appropriate 2200 system check-out listed below:

<u>System</u>	<u>Diagnostic</u>
LVP	System Exercisor 732-0002B Rev 61B4
MVP	Peripheral Diagnostic 702-0079 Rev 1.0

7. FCO KIT PARTS LISTING

KIT #728-0046

<u>Item</u>	<u>Qty</u>	<u>Item Description</u>
729-1297	1	FCO #1035 Document
300-1390	1	390 pf Cap
300-3009	1	30 uf Cap
615-1283-1	1	E-Rev 1 Sticker

8. FCO KIT AVAILABILITY DATE

FCO Kit #728-0046 will be available June 6, 1983. It can be obtained by placing a routine order through Logistics Order Processing System.

9. REMOVED PARTS DISPOSITION

N/A

10. MISCELLANEOUS

N/A



FIELD CHANGE ORDER

FCO NO.
1005A

Equipment Affected 2200 SVP/LVP
 Class NEXT CALL FCO Kit # *(-A)728-0013-A Page 1 of 6
 Org. Code IV.A.3. FCO Doc. # *729-1091-A Approval Date: MAR 9 1983
 Est. Install. Time ONE HOUR Ref. ECO # *22452, 26044

ASTERISK (*) INDICATES CHANGE

* This FCO supersedes FCO 1005

1. REASON FOR CHANGE

- A. An I93 error would occur when copying across an alternate sector on a Shugart Winchester Disk.
- B. The Data Processing Unit (DPU) would not pass power-up diagnostics when its switches were set to floppy only.
- * C. Floppy door will unlock after 5 seconds of non-use.
- * D. A format error found within the alternate sector during a FORMAT DISK operation is now recovered by the software.

2. DESCRIPTION OF CHANGE

- * A. To update EPROM's of the 210-8696-A with 378-4220-R9 (L29), 378-4221-R9 (L28), 378-4222-R9 (L27) and 378-4223-R9 (L26) EPROM's.
- * B. To update EPROM's of the 210-8696-B with 378-4220-R9 (L29), 378-4221-R9 (L28), 378-4222-R9 (L27) and 378-4230-R9 (L26) EPROM's.

NOTE: The EPROM # for L26 is different depending on disk capacity.

3. DOCUMENTATION AFFECTED

N/A

4. PREREQUISITE (S)

The 210-8696-A/-B should be at E-Rev 0 before installation of this change.

Tech Ops <i>John Riley 3/3</i>	Logistics <i>John Proctor 3/3</i>	Originator <i>John Proctor 3/3</i>	FCO Coordinator <i>John Proctor 3/3</i>
-----------------------------------	--------------------------------------	---------------------------------------	--

5. INSTALLATION PROCEDURE

CAUTION:

THIS CHANGE INVOLVES DEVICES THAT CAN BE DEGRADED OR DESTROYED BY ELECTRO-STATIC DISCHARGE (ESD). TO INSURE OPTIMUM/RELIABLE EQUIPMENT OPERATION IT IS REQUIRED THAT TECHNICAL SUPPORT PERSONNEL DISCHARGE THEMSELVES BY PERIODICALLY TOUCHING THE CHASSIS GROUND PRIOR TO AND DURING THE HANDLING OF SUCH DEVICES.

- A. Ensure power is off. Remove the 2200 circuit board cover.
- B. Remove the 210-8696 board. (See Section 10 - MISCELLANEOUS)
- C. 210-8696-A Procedures
 - o Remove EPROM's of the 210-8696-A in locations L29, L28, L27 and L26.
 - * o Replace with updated EPROM's - 378-4220-R9 (L29), 378-4221-R9 (L28), 378-4222-R9 (L27) and 378-4223-R9 (L26).
- D. 210-8696-B Procedures
 - o Remove EPROM's of the 210-8696-B in locations L29, L28, L27 and L26.
 - * o Replace with updated EPROM's - 378-4220-R9 (L29), 378-4221-R9 (L28), 378-4222-R9 (L27) and 378-4230-R9 (L26).
- E. Note the locations of pin 1 and ensure that the EPROM legs are securely seated in the socket.
- F. Reinsert the 210-8696-A/-B board into the 2200 unit.
- G. Run check-out procedures. (See Section 6)
- H. Turn off power and reassemble circuit board cover to original configuration.
- I. Document installation of the upgrade by properly completing a Call Report or Activity Report.

210-8696-A
R1
FCO 1005A

FCO #1005A

8696-R:

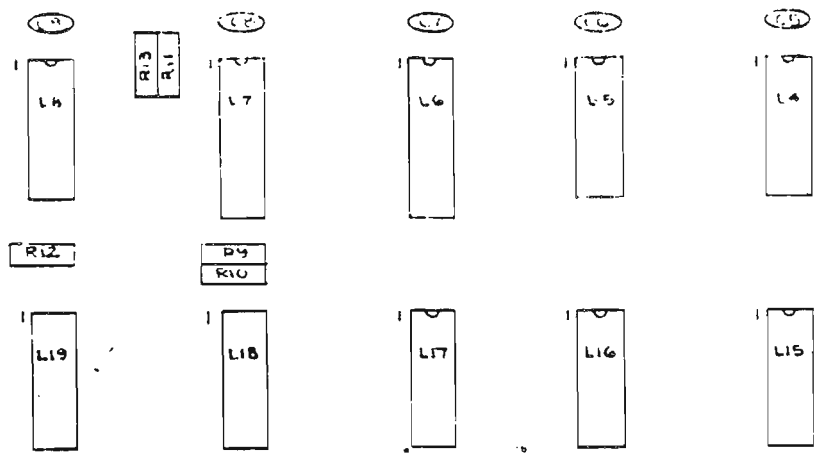

NOTE THE LOCATIONS OF PIN 1

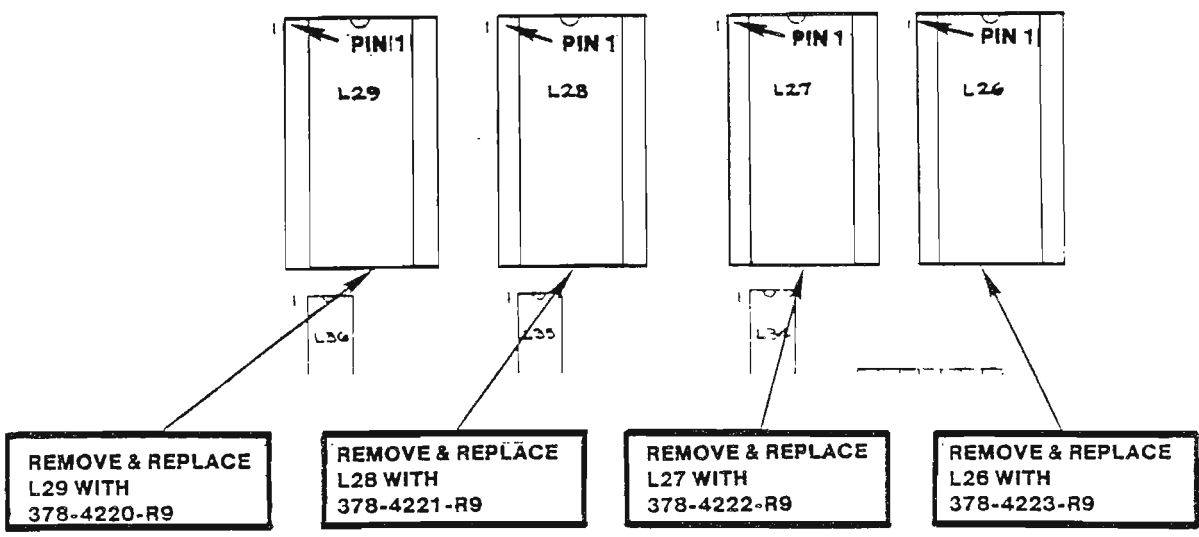

210-8696-B
R1
FCO 1005A

FCO #1005A

8696-R1

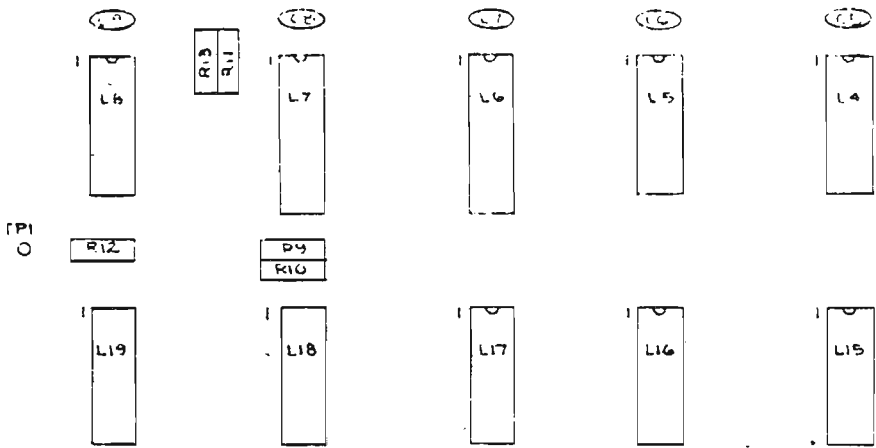

NOTE THE LOCATIONS OF PIN 1

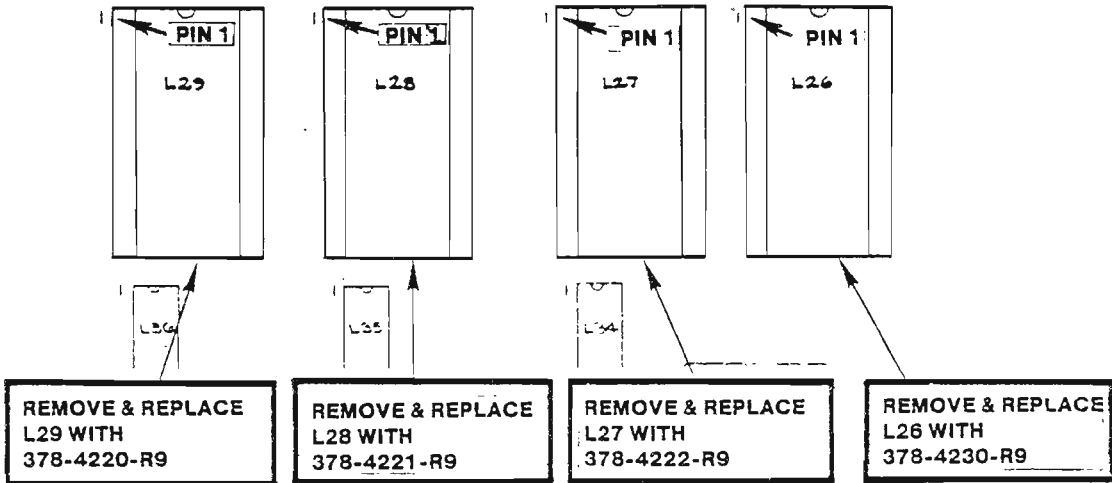

6. CHECK-OUT PROCEDURE

- A. Turn on the 2200 unit and ensure that the DPU has passed its power-up diagnostics. (All four LED's of the 210-8696 board will be "off".)
- B. Run the LVP/SVP disk exerciser (WL# 732-0008A).

7. FCO KIT PARTS LISTING

- * 210-8696-A (Kit# 728-0013-A)

Item #	Item Description
729-1091-A	FCO# 1005A
378-4220-R9	2716 EPROM
378-4221-R9	2716 EPROM
378-4222-R9	2716 EPROM
378-4223-R9	2716 EPROM

- * 210-8696-B (Kit# 728-0015-A)

Item #	Item Description
729-1091-A	FCO# 1005A
378-4220-R9	2716 EPROM
378-4221-R9	2716 EPROM
378-4222-R9	2716 EPROM
378-4230-R9	2716 EPROM

8. FCO KIT AVAILABILITY DATE

- * FCO Kit#'s 728-0013-A and 728-0015-A will be available March 21, 1983. They can be obtained by placing a routine order through the Logistics Order Processing system.

9. REMOVED PARTS DISPOSITION

Recycle removed EPROM's through your FSC.

10. MISCELLANEOUS

- A. There are two versions of the 210-8696 board, (-A) and (-B). The 210-8696-A is used with the 4, 8, 16 and 32 Meg Winchester Drives. The 210-8696-B is used only with the 2 Meg Shugart Winchester Disk Drives.

* B. FCO 1005A pertains primarily to units that experience the problems noted in Section 1, paragraphs C and D. R9 PROM's should be installed in units that:

- 1) still have R7 PROM's installed
- 2) exhibit problems noted in Section 1, paragraphs C and D

It is not necessary to upgrade units with R8 PROM's unless it is experiencing the problems noted in Section 1, paragraphs C and D.

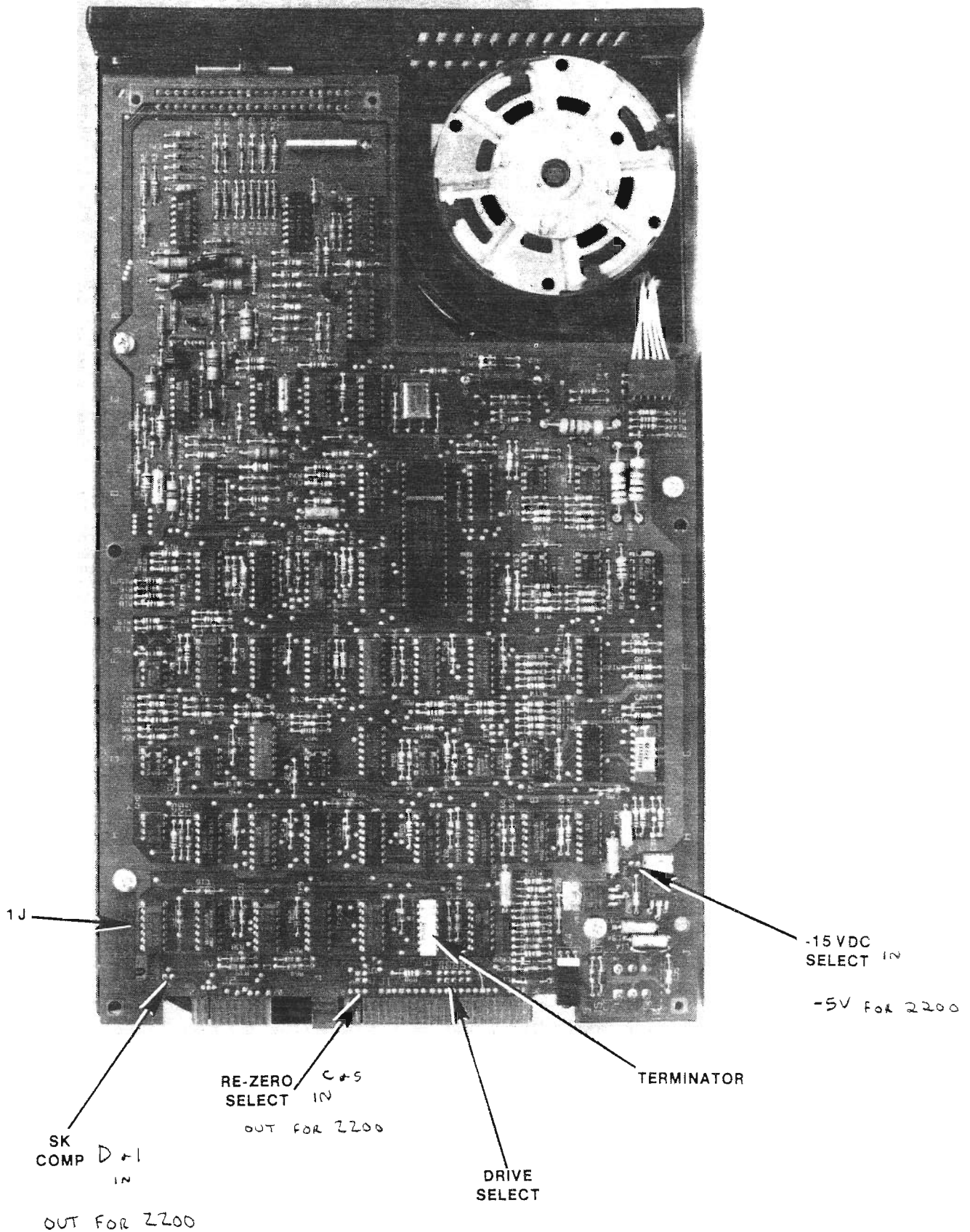

Figure 5-29. Quantum Drive Jumper Options

LVPCQuantum Drive

ONLY SUPPORTED ON LVPC.

The new Quantum Disk Drive is now in the field. The drive comes in 2 models, a 16 meg and a 32 meg. The 2 cables from the Quantum should connect to the middle 2 connectors on top of the motherboard. (red wire is pin 1)

FIXED 1, CONN 2+3. FORMAT PROB W/ FIXED 2, CONN 4+5.

MODEL	PLATTERS	ADDRESSING	PART NUMBER
Q2020 (16 Meg)	2	310,320,330 sectors 0 to 65407	278-4024
Q2040 (32 Meg)	4	D11,D21, or D31 sectors 0 to 65407 D12,D22, or D32 sectors 0 to 65407	278-4025

The drive is shipped with 2 locks, one on the actuator and one on the spindle. Both locks are found on the side opposite the PC board.

Spindle Lock

Loosen 11/32 hex nut, rotate away from pulley and tighten. (do not rotate pulley)

Actuator Lock

Unlock by turning with a straight edge screwdriver counterclockwise as far as it will go which is approximately 1/4 turn.

When power is turned on to the Quantum under proper operation, the heads should raise up, lower down, raise again in 5 or 6 stepping motions, and once again lower. This can be seen by looking down through the glass between the spindle motor and the PC board.

The 16 meg Quantum is addressed as any single fixed disk would be and takes approximately 30 minutes to format. The 32 meg Quantum is addressed the same way the first two fixed surfaces of a Phoenix would be addressed. Using address 310 as selected by the 94 board, the 32 Meg Quantum would be addressed by using D11 and D12 and each address requires 30 minutes to format. All Quantum addresses should be formatted upon installation.

DPU Boards for the Quantum

-210-7694/210-8694/210-8794 (next to I/O connectors)

The 210-8794 should be used with all Quantums and must be used to access both addresses of the 32 meg. The 210-8694 could be used for test purposes or with the 16 meg temporarily but should be at E-REV 3. A 210-7694 might also possibly be used but should be the equivalent of an 8694 E-REV 3. The 76 series boards are being phased out.

The 94 contains the device address switch. 4 on=310, 3 on=320, and 3 and 4=330.

The 94 board also has the pots on it for the PLL adjustment and the new PLL adjustment diskette, 732-0009A, is needed with the Quantum.

-210-7696/218-8996 (middle board of DPU)

The 210-8696 with R8 proms should be used. Do not use R7 or R6 proms as these proms have a known problem. R5 proms may work but you might not be able to access the second address on the 32 meg. The 7696 will probably work the same but you should try to stay with the 86 series.

The switch bank on the 96 board identifies what disk drives are installed and should be set as follows:

Switches	#1, #5, #7	Always On
	#3	Always Off
	#6	On=No Floppy, Off=Floppy installed ^{IN R}
	#2, #4, #8	All On=No Fixed Drive
		2 and 8 On=2 meg or 4 meg Winchester
		4 and 8 On=8 meg Winchester
		2 and 4 On=16 Meg Quantum
		4 On=32 Meg Quantum
		8 ON = FLOPPY IN FIXED

-210-7695/210-8695/210-7925 (next to 6793-1 board)

The 210-7925 should be used with all Quantums and is mandatory to access both addresses on the 32 meg. Again a 210-8695 or even possibly a 7695 with at least R2 proms at L1 and L2 should work as a temporary fix or for test purposes. The 7925 board also corrects a possible I93 problem that may occur with the 8695.

In conclusion the DPU for the Quantum should consist of a 210-8794, a 210-8696 with R8 proms, and a 210-7925 although other combinations may work.

2200

LVP/SVP

Proms on 8696 Board

Proms on the 8696 board are now at revision R8. Revision R5 may still be used but do not use R6 or R7. A new phase Lock Loop Diskette is needed with the R8 proms as the older version PLL diskette, part number 732-0009, will not operate properly with the Winchester. The new PLL alignment disk is part number 732-0009A.

LVP/SVPCompatibility Problem Between Single And Three Board DPU's

A compatibility problem has been found between the single board DPU (210-7890A) and the three board DPU. Platters created on the three board DPU will give intermittent I93 and I96 errors when read by the single board. Until the problem is resolved by R & D, all platters to be used with the single board DPU will need to be formatted and written by the single board DPU. With a two floppy drive system, this usually can be easily done by formatting a new disk and copying the platter created by the three board DPU onto it. If you have this problem, please call the District.

Single Board DPU PLL Adjustment (210-7890A)

While in the idle state monitor TP2 (lower test point between L11 and L12) and adjust pot for a 500 nanosecond duty cycle. Power on and off and insure signal remains steady.

Scope Settings: CH 1 at 2V/Div to TP2 of 7890A
 Trig. CH 1 Normal DC + .1 msec/Div

To check out, format a platter, write the worst case test pattern on it using the PLL program, SF key 5 for R and SF 6 for F, and verify that pattern, SF key 1 for R and SF 2 for F, but do not adjust unless it fails. If using a two floppy unit, swap platters between the drives and again using SF 1 and 2. Finish testing with a copy and 10-15 minutes of random R/W. Use PLL adjustment disk 732-0009A.

Three Board DPU PLL Adjustment

To do a proper adjustment of the phase lock loop a PLL adjustment disk is needed, Part # 732-0009A, and a platter formatted on an aligned and properly adjusted drive with a worst case test pattern on it. This will be your master disk.

1. Ground TP1 of the 94 board and, while monitoring L5 pin 1 or 2, adjust the left most pot (connectors down, component side) for 4V. If system was in use, record previous voltage reading.
2. Load PLL adjustment program, insert master disk, select "Adjust Floppy," and adjust center pot midway between each end where it starts to error.
3. Once centered, let run for a full screen of dots.
4. Insert a good scratch disk, select number 5, and write worst case test pattern on floppy.
5. Select "Adjust Floppy" and again adjust center pot midway between each end where it starts to fail. If there is not at least one full turn between erroring points, there is something wrong and intermittent errors will probably result. One and a half turns or more is very good. Again get a full screen of dots without errors.
6. If 4 volts was off, the Quantum or Winchester should be formatted, then select SF 6 and write the worst case test pattern on the fixed. No data is disturbed by writing or verifying the worst case test pattern.
7. Select "Adjust Winchester" and center right most pot (connectors down, component side) between each end where errors start to occur. Must get at least one full error free turn and a full screen of dots. "Winchester," as referred to in the PLL program, is misleading as it really should say fixed because it will also work with a Quantum or fixed floppy.

** If these adjustments are found off all disks created by that drive should be reformatted. On every LVP and SVP installation, these adjustments should be checked or whenever experiencing disk errors.

LVP/SVP

No Mount System Platter Message With Power On

A recent TAC Newsletter has reported a problem with no "Mount System Platter" message with power on due to the new Shugart Winchester Drives (only one board mounted on drive). This could be tested by removing the I/O cables from the Winchester and powering on.

This problem should be correctable by a second or third power on. R and D is working on the problem and the drive should not be replaced unless the problem is very persistent and requires a number of power ons to work properly.

Heat Related I93's and I96's

There have been frequent heat problems that have arisen with the 210-7694/8694 DPU boards in the SVP/LVP systems. The symptoms are:

I93 or I96 when trying to read or write to the disks, especially the DSDD floppy drives. Ususally, leaving off the card cage cover would resolve this problem.

There is a known fix for this. IC 'L5', which is the pluggable chip on the 7694, 8694, is a plastic coated chip which is heat sensitive. We now have a ceramic chip which can withstand the heat in the card cage. The identifying numbers on these chips are as follows:

Plastic - 745124	WPN 376-0273
Ceramic - 745124	WPN 376-0273-1

If you are experiencing this problem, please notify the District office before replacing chips or boards.

MVP/LVPWorkstations Intermittently Hanging Up

If you have a customer experiencing an intermittent problem with workstations hanging up it may be because of R7 proms being used with the 210-7591 daughterboard on the MUX D board. Try downgrading the R7 proms to R6 or replacing the 210-7591 with the 210-7291 daughterboard. This is a temporary fix.

NOTE: The 2236DW Workstations requires R7 proms and the 210-7591 board so you can not make these changes if the customer has DW terminals.



Option C

Option C which allows up to 64K Control Memory and 512K Data Memory has recently been made available on MVP and LVP CPU's. The extra control memory is necessary to support COBOL and BASIC-3.

With both the MVP and LVP a new motherboard is required and in the case of the MVP a-chassis as well. The new motherboards have 7 I/O slots.

On all CPU's with option C, 2 new boards are required to handle the increased memory. The new Extended Instruction Counter Board, 210-7797, replaces the 6790 and the new Extended Memory Controller Board, 210-7796, is installed between the 2 Control Memory Slots and the 4 data memory slots.

For proper operation of Option C the following list should be helpful.

1. MVP must have MVPC chassis with motherboard (7 I/O slots) 270-0465
LVP must have LVPC card cage/motherboard ass'y(7 I/O slots) 270-0467
2. MVPC must have a 210-7397 regulator which will not come with upgrade.
3. MVPC/LVPC must have the Extended Memory Controller Board, 210-7796 (inserted in slot between 2 control memory slots and 4 data memory slots).
4. MVPC/LVPC must have the new Instruction Counter Board 210-7797 (replaces the 210-6790 board)
5. MVPC/LVPC with data memory greater than 256K must have a 210-6793-1 updated to at least E-REV 4.
6. 
 only 1 Control Memory Board is needed; it must be installed in control memory slot #2 next to the 210-7796 boards.
210-7588 AT LEAST 6 REV 3
7. MVPC/LVPC with data memory greater than 256K must have a 210-6789 board with at least R4 proms. (R3 may work but might have some bugs)

R3 OK

8. MVPC/LVPC with 64K control memory or greater than 256K of data memory must use software release MVP 2.3 to utilize the added memory.
9. The 210-6790 must be at least E-REV 5 and the 210-6791 must be at least E-REV 3 to support greater than 64K data memory.
10. All LVPs use +5V2 for any I/O slot after the first 3 I/O slots. This voltage can be measured at connector J3 pins 1 and 3 on the regulator board or pin B, of the I/O connectors.

MVPC/LVPC

CONTROL AND DATA MEMORY ERRORS WITH 512K

There is a possible problem with MVPC/LVPC with 512K Memory. Most common symptoms are:

PECM AA XXXX or PEDM AA XXXX

and removing the fourth memory board eliminates the problem. As long as the fourth slot is empty any 3 of the boards work fine.

Problem appears to be sensitivity with the 6791 board and trying several 6791's may produce a working solution.

R&D is working on the problem now.

INTERMITTENT PARITY ERRORS (PEDM) WITH C CHASSIS

If experiencing intermittent parity errors with a C chassis, updating the 6791 board to a 6791-1 might help. Although any board in the CPU can cause a PEDM, a problem has been found with some 6791 boards which updating should correct. To upgrade from a 6791 to a 6791-1 change the 4 chips at L38, L39, L40, and L41 to Fairchilds. The 6791 board must be at least an E-REV 3 to be used in a LVPC. All C chassis should have the 6791-1 board.

Fairchild Chip - 376-0203-1

Fairchild chips can be identified by the letter F on them followed by the number 74191 PC.

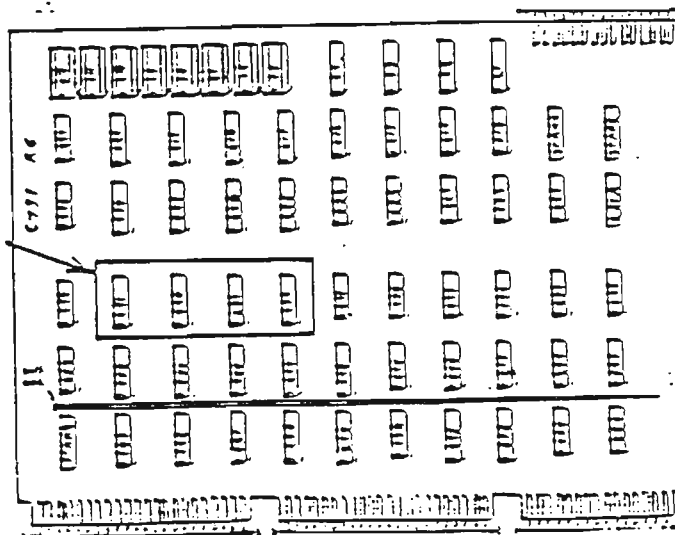

LVP/MVP

HANG UP PROBLEM WITH MUXD CONTROLLER

A legitimate solution has been found for terminals hanging up using the MUXD board with 210-7591 daughterboard and R7 proms. Previously the solution was to either downgrade the proms or the daughterboard if both weren't needed for 2200 Word Processing.

The fix involves installing two capacitors on the 210-7591 PCA (see picture)

1. Add a 390 pf capacitor (WLI 300-1390) between L6-pin 13 and plus/minus 0 volts. (use L6 pin 7 for +/- 0V)
2. Add a 35uf capacitor (WLI 300-3009), negative side to Q2 - pin 2 (-5V output) and positive side to plus/minus 0V. (use Q2 pin 1 for +/- 0V).

Another aid in eliminating intermittent hangups may be to insert the MUX D Board into the first I/O slot closest to 210-6793 board of the CPU section. After insertion, adjust 12 volts at the last I/O slot to approximately 12.1 volts. 12 volts can be adjusted at connector 3, bottom connector, of I/O slot, pin 15. (bottom pin). Ground reference is pin 13 (3rd from bottom).

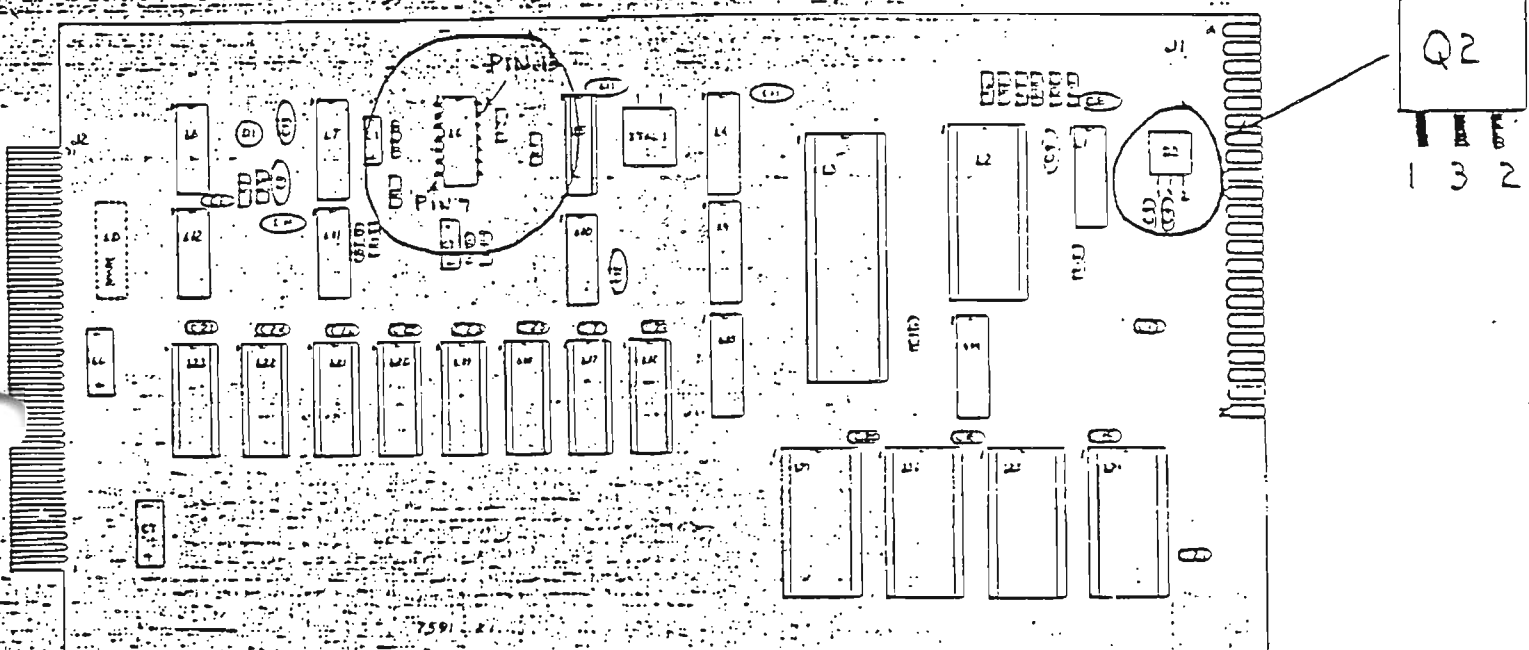

INTERMITTENT PARITY ERRORS (PEDM) WITH C CHASSIS

If experiencing intermittent parity errors with a C chassis, updating the 6791 board to a 6791-1 might help. Although any board in the CPU can cause a PEDM, a problem has been found with some 6791 boards which updating should correct. To upgrade from a 6791 to a 6791-1 change the 4 chips at L38, L39, L40, and L41 to Fairchilds. The 6791 board must be at least an E-REV 3 to be used in a LVPC. All C chassis should have the 6791-1 board.

Fairchild Chip - 376-0203-1

Fairchild chips can be identified by the letter F on them followed by the number 74191 PC.

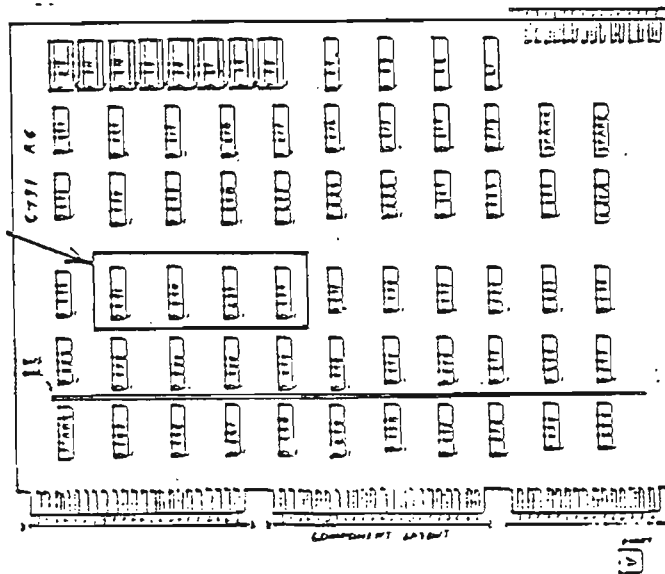

MVP/LVP

2236MXE CONTROLLER 212-3022

The 2236MXE Terminal Controller has recently hit the field and will support 2236D, DE, DW and 2336DW terminals. The controller has its own 48K of RAM to allow it to perform several functions previously performed by the CPU. Some of the enhancements provided with this controller are:

1. "Time of Day" clock circuitry (optional battery back-up).
2. Baud Rate for each port switch and software selectable.
3. 8K prom provides bootstrap functions, power up diagnostics, and remote diagnostics.
4. Ability to set any terminal as Primary User.

With initial power on, the power on diagnostics will be run, which takes about 6 seconds and checks the majority of the MXE hardware. While this is taking place an LED at the top of the external edge is lit and if there are no problems the LED will go out after the 6 seconds.

To use the MXE board however, MVP 2.4 operating system is necessary as otherwise when RUN is keyed from the LOAD MVP/LOAD diagnostic menu the system will just hang up. Thanks to Tim Coughlin of the Providence office for his help with this information.

Switch settings

	Switch Bank 1			
# of MXE	1	2	3	4
First	off	off	off	off
Second	on	off	off	off
Third	off	on	(off	off)
			(not used)	

HARDWARE SWITCH SETTINGS

BAUD RATE	SWITCH 3				SWITCH 2			
	PORT 1		PORT 2		PORT 3		PORT 4	
	1	2	3	4	5	6	7	8
110	OFF	OFF	OFF	OFF	OFF	OFF	OFF	OFF
134.5	ON	OFF	OFF	OFF	ON	OFF	OFF	OFF
150	OFF	ON	OFF	OFF	OFF	ON	OFF	OFF
200	ON	ON	OFF	OFF	ON	ON	OFF	OFF
300	OFF	OFF	ON	OFF	OFF	OFF	ON	OFF
600	ON	OFF	ON	OFF	ON	OFF	ON	OFF
1200	OFF	ON	ON	OFF	OFF	ON	ON	OFF
UNDEFINED	ON	ON	ON	OFF	ON	ON	ON	OFF
2400	OFF	OFF	OFF	ON	OFF	OFF	OFF	ON
UNDEFINED	ON	OFF	OFF	ON	ON	OFF	OFF	ON
4800	OFF	ON	OFF	ON	OFF	ON	OFF	ON
UNDEFINED	ON	ON	OFF	ON	ON	OFF	ON	ON
9600	OFF	OFF	ON	ON	OFF	OFF	ON	ON
19,200	ON	OFF	ON	ON	ON	OFF	ON	ON
BINARY	1	2	4	8	1	2	4	8
	L S D			M S D	L S D			M S D

2336DW ERGO TERMINAL
PART NUMBERS AND SWITCH SETTINGS

The new Ergo Workstation is out in the field and is basically the same as a 2236DW with the added Ergo features of tilting screen and detachable keyboard. Local terminals on MVP/LVP may be a maximum of 2000' while on VP/SVP maximum local distance is 50'. The controller board for these terminals must have it's proms up to current standards to support these terminals.

1. MUX D daughterboard - 210-7591A R7 proms 378-2140/41/42/43
2. Triple controller daughterboard - 210-7516A R1 proms 378-4092/93
3. Triple controller daughterboard - 210-7816A R1 proms 378-2591/2449/50/51
4. SVP controller board - 210-7789A R1 proms 378-4092/93

Parts List

- Terminal Control Board 210-7743A (should have following proms - 378-5080R1, 378-6013R4, and 378-6014R4)
- Standard Keyboard 725-2637
- Expanded Keyboard 725-2652 (identified by uppercase characters on numeric keypad)
- 12" Monitor Board 210-7456
- 12" Tilting CRT Assembly 270-0633
- Power Supply 270-0734
- KEYBOARD CABLE 220-1246

The first Ergo terminals released on the 2200 product line were actually repackaged 2236DE/DW's using the same 7592 board. The model number on this unit should be 2886. There seems to have been some mislabeling with model numbers with some 2336DW's being labeled 2886.

Switch Settings

Use odd parity, 8 data bits

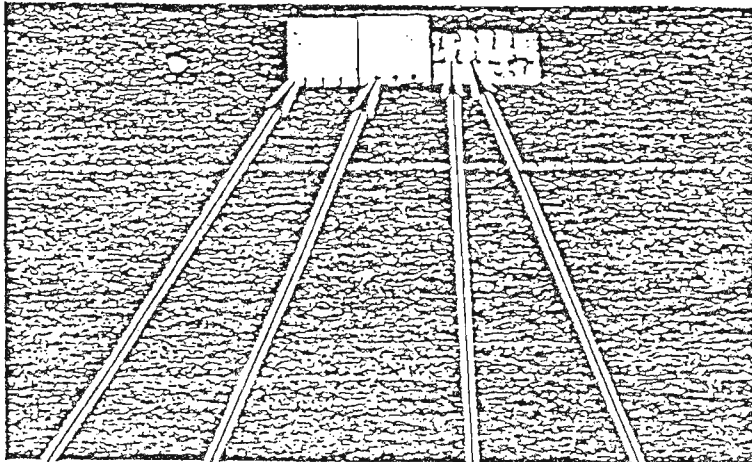

CLICKER
POT

SPEAKER
POT

SW1

SW2

UP	DOWN
EVEN PARITY	ODD PARITY

UP	DOWN
8 DATA BITS	7 DATA BITS

SWITCH			BAUD RATE
3	4	5	
DOWN	DOWN	DOWN	300
DOWN	DOWN	UP	600
DOWN	UP	DOWN	1200
DOWN	UP	UP	2400
UP	DOWN	DOWN	4800
UP	DOWN	UP	9600
UP	UP	DOWN	19.200



LABORATORIES, INC.

2236 110X D - FOR 17.2 K

SWITCH SET AT 4800 + JUMP
BETWEEN L18 + L19 FROM A - B
FOR 4800 FROM A - C

2236DE .BAUD RATE SWITCHES

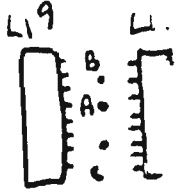

SWITCH NUMBER					PARITY	DATA BITS	BAUD RATE	
5	4	3	2	1				
	OFF	OFF	ON	OFF	OFF	NONE	8	19.2K
X	OFF	OFF	ON	OFF	ON	ODD	8	19.2K
	OFF	OFF	ON	ON	OFF	EVEN	7	19.2K
	OFF	OFF	ON	ON	ON	ODD	7	19.2K
	OFF	ON	OFF	OFF	OFF	NONE	8	9600
X	OFF	ON	OFF	OFF	ON	ODD	8	9600
	OFF	ON	OFF	ON	OFF	EVEN	7	9600
	OFF	ON	OFF	ON	ON	ODD	7	9600
	OFF	ON	ON	OFF	OFF	NONE	8	4800
X	OFF	ON	ON	OFF	ON	ODD	8	4800
	OFF	ON	ON	ON	OFF	EVEN	7	4800
	OFF	ON	ON	ON	ON	ODD	7	4800
	ON	OFF	OFF	OFF	OFF	NONE	8	2400
X	ON	OFF	OFF	OFF	ON	ODD	8	2400
	ON	OFF	OFF	ON	OFF	EVEN	7	2400
	ON	OFF	OFF	ON	ON	ODD	7	2400
	ON	OFF	ON	OFF	OFF	NONE	8	1200
X	ON	OFF	ON	OFF	ON	ODD	8	1200
	ON	OFF	ON	ON	OFF	EVEN	7	1200
	ON	OFF	ON	ON	ON	ODD	7	1200
	ON	ON	OFF	OFF	OFF	NONE	8	600
X	ON	ON	OFF	OFF	ON	ODD	8	600
	ON	ON	OFF	ON	OFF	EVEN	7	600
	ON	ON	OFF	ON	ON	ODD	7	600
	ON	ON	ON	OFF	OFF	NONE	8	300
X	ON	ON	ON	OFF	ON	ODD	8	300
	ON	ON	ON	ON	OFF	EVEN	7	300
	ON	ON	ON	ON	ON	ODD	7	300

MVP/LVP & VP/SVP OPERATING SYSTEM RELEASE 2.2/2.4

The following is the memo and marketing release on the new MVP/LVP operating system release 2.2, and the new VP/SVP operating system release 2.4.

One of the new features is the CPU identification number. This number is contained in the PROMs located on the 210-6789 PCB. The PROM numbers and location are as follows:

L27	378-2045-R3
L28	378-2046-R3
L29	378-2047-R3

These PROMs were updated to R3 in MUB release #19, dated April 30, 1981.

If your customer is using a vendor's software package that is software protected, and the 210-6789 PCB becomes defective and must be replaced, these PROMs must be removed from the defective PCB and installed on the new PCB. Failure to do so will result in the inability to run the vendor's software protected programs.

A new numeric function, #ID, returns the CPU identification number. Each 2200 CPU is assigned a number (a random integer between 1 and 65535) at the time of manufacture. Machines produced prior to the implementation of this feature return a value of 0, but such machines can be field upgraded to have non-zero #ID's. CPU ID's are not guaranteed to be unique, but it is highly unlikely two given machines will have the same number.

This function allows software to tell one CPU from another. The ability to distinguish one CPU from another is useful in restricting software to specific installations and in telling one CPU from another when disk multiplexers are used.

LVPC

R1 Motherboard Problems

There has been a problem found with 210-7799 R1 motherboard causing intermittent errors. Apparently a lot of ECN work has been done to these boards and it has been found that the associated wires may be getting crimped. A problem possibly aggravated by removing and inserting the PC boards. This problem first appeared to be loose connectors but this proved false.

If you do have a R1 motherboard that is suspected of problems please check the ECN wiring for crimps and shorts, as some time may be saved troubleshooting. The 210-7799R2 motherboards do not have jumpers on them to cause this problem.

QUANTUM DISK DRIVES

COMPATIBILITY ACROSS PRODUCT LINES

Before installing a replacement Quantum Drive into a VS-25 or VS-45, check the following to insure compatibility:

1. Quantum Drives with PCB's at Rev. E or above this Rev. are compatible with OIS/LVP/VS-25/VS-45 systems.
2. If a drive from stock has a PCB with a lower Rev. (below Rev. E) it cannot be used on the VS-25 or VS-45, but can be used in the OIS and LVP.

NOTE: Board below Rev. E can be identified by the IC 7438 missing at location 1J.

QUANTUM DISK DRIVES

SELF DIAGNOSTICS

Every Quantum Disk Drive has a built in self diagnostic which can be used to troubleshoot the drive without destroying any customer data that may be present on the disk. The diagnostic is a seek test and does not verify the R/W circuitry. Proceed as follows:

- Step #1: Disconnect the Wang cables connected to the drive in positions J2 and J3.
- Step #2: Put jumper (E4) in place on the main PCB.
- Step #3: Turn Wang System "ON", drive uses the power for the logic and for the motor.

If the diagnostic jumper (E4) is in place the processor starts the diagnostic "seek program". This program commands the actuator to a seek pattern mode by using an internal track number register to monitor track position. The self-diagnostic implements an algorithm to access different tracks.

This pattern checks all possible length seeks plus checks for seek errors on every other seek (whenever the arm is at track zero).

When an error occurs in the self-diagnostic mode, "READY" is dropped and the arm returns to the inner crash stop under spring power, media will continue rotating. The drive is left in this state until jumper E4 is removed. While E4 is still installed, an error code is latched in the 74LS374 at location 7E. The three least significant bits in this register are used to hold a binary-encoded error number. Five different error codes exist. These are:

Error Number	IC 7E			REASON FOR ERROR
	Pin 19	Pin 5	Pin 2	
1	0	0	1	No servo detected
2	0	1	0	Seek error in diagnostic (the micro processors internal cylinder address register does not agree with the track zero flag. Either track zero is present and the CAR is not zero, or the CAR is zero, but track zero is false).
3	0	1	1	No track crossing occurred in 15 ms during the slow speed seek mode.
4	1	0	0	No track crossing occurred in 2.5 ms during the high speed seek mode.
5	1	0	1	Drive did not seek to targeted track.

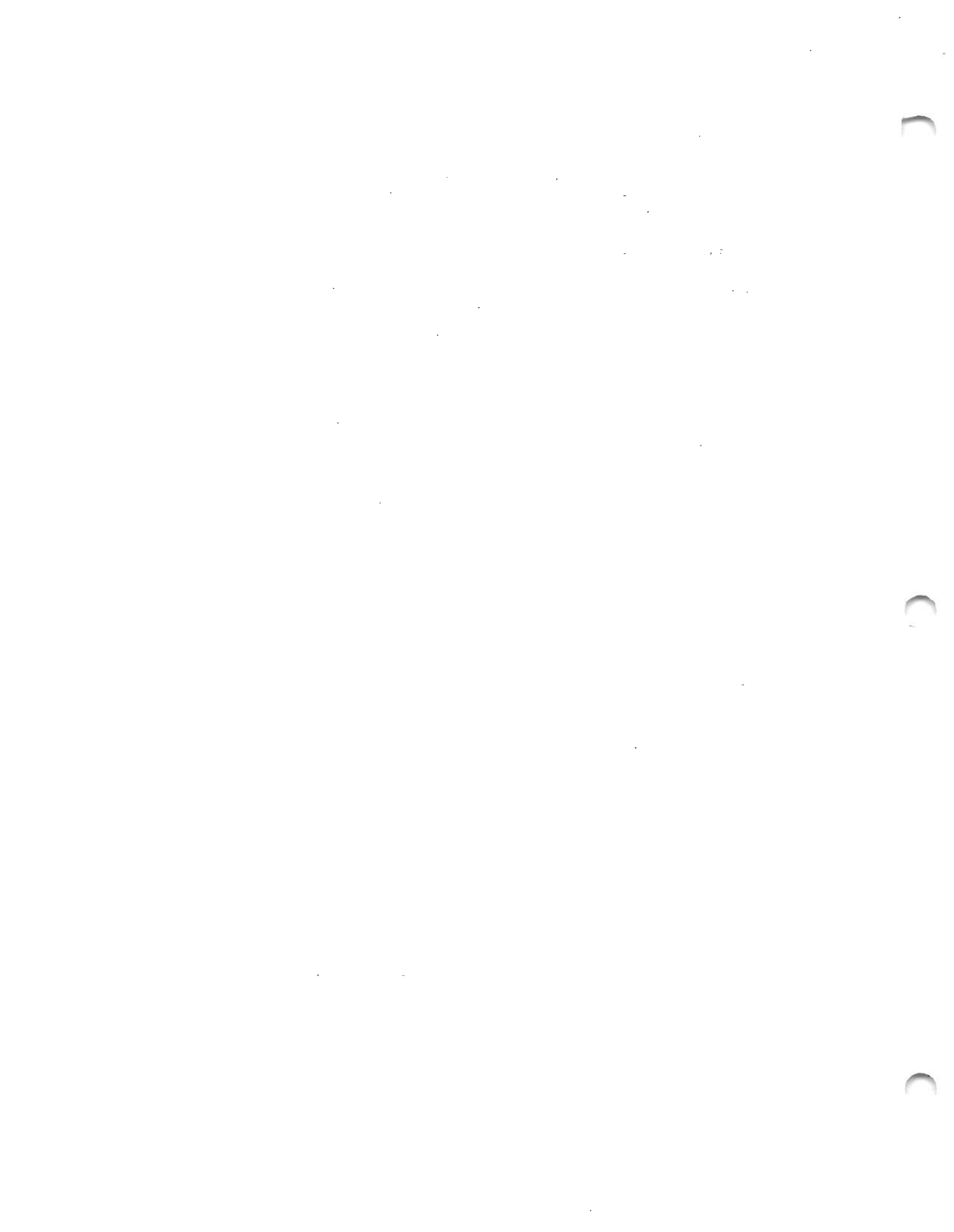

2336DE/DW ERGO TERMINALS

PROBLEM KEYING RESET WITH SYSTEM LOADED AS VP

There has been a problem found with the 2336 Ergo Terminals where if the system is loaded as a VP keying reset will cause "INIT" to be printed on the screen.

This only happens with MUXD controllers as the MUXE works ok. Home office is aware of the problem.

If this problem is encountered do not attempt to fix it as it is normal and anyone with a MUX D controller would normally be loading their system as an MVP.

Thanks to Gabe Moran of Burlington North and Dan Dwyer of Brockton for their assistance with this information.

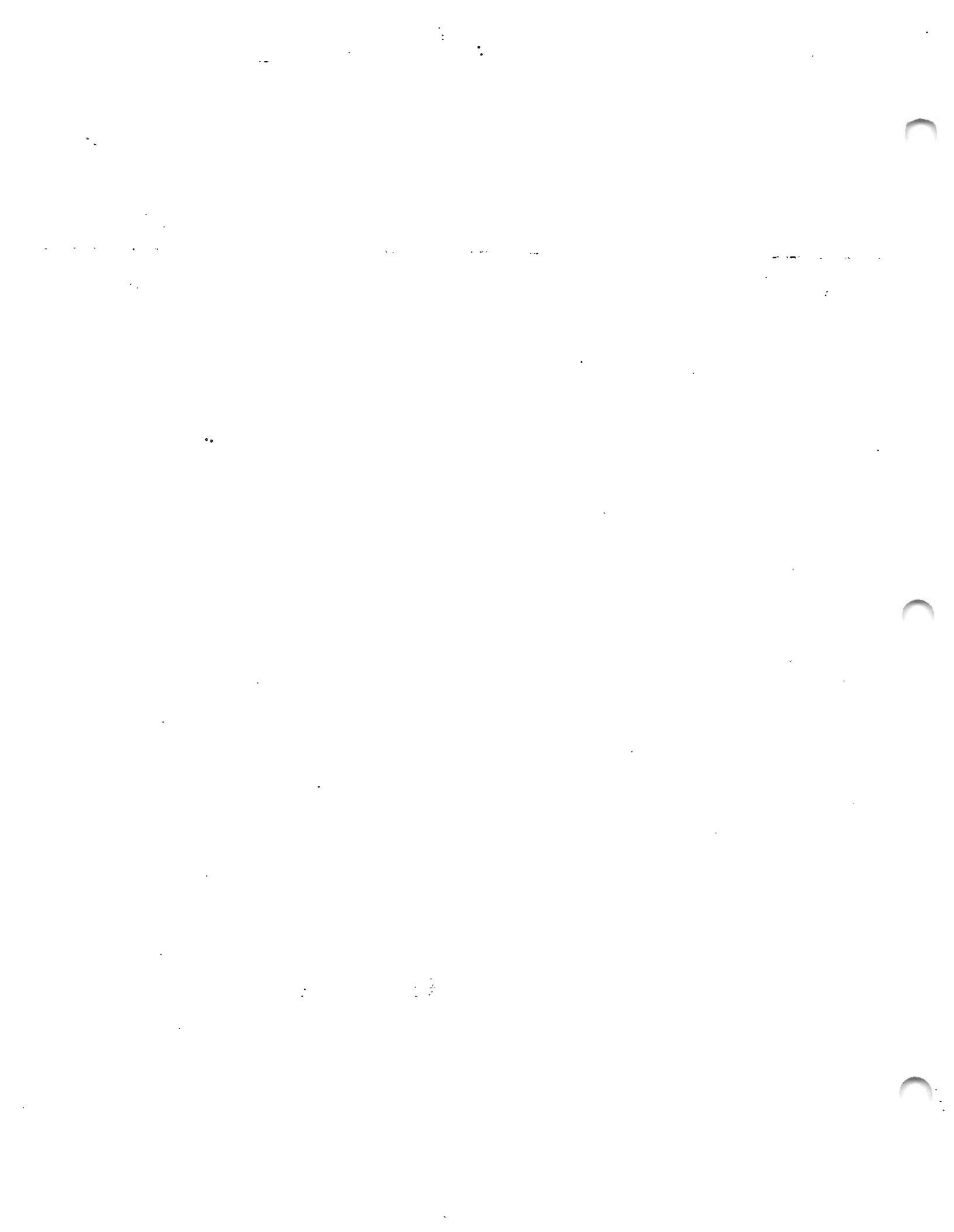

LVP/SVP

NEW STYLE CASING FOR WINCHESTER DRIVE

The 8 meg Winchester drive, # 278-4014, is electronically the same for OIS and 2200 LVP use. The case however is different. The "OIS" casing will not fit in a LVP chassis without a bracket which is supposed to be shipped with the drive. The bracket can be ordered under P/N 452-0190.

Thanks to Fran Staffieri and Lynn Eldridge for this information.

2200

LVP

FAN CHANGE

The fans currently used with the LVP have a shroud which restricts air flow to boards not directly under the fan. To increase the air flow and to allow the unit to run cooler thereby increasing the life of the boards, skeleton fans should be installed, especially in hotter environments.

Skeleton Fan - 400-1011

DSDD SHUGART SA850/851

CORRECTION FOR JUMPER SETTINGS

In District Newsletter #18 there was a mistake in jumper settings of the DSDD Shugart. Under section "B. Unique Jumpers for 2200 LVP/SVP" the last statement is incorrect. It should read pin 8 of IC-3E instead of pin 2 of IC-3E. Please make that correction.

If these jumpers are not correct you could experience problems that look like software. One problem encountered was anytime a formatted floppy disk was listed any removable disk listed thereafter would show "INDEX SECTORS=00000" as the heads were not actually loading. Listing the fixed disk or powering off and on would correct the symptom. However a clear would not and a \$INIT"SYSTEM" and an attempt to reload the operating system would give an I92.

This drive appeared to be the unit shipped with the LVP so beware. The problem also created havoc trying to run the recover routine but ran R/W tests and formatted fine.

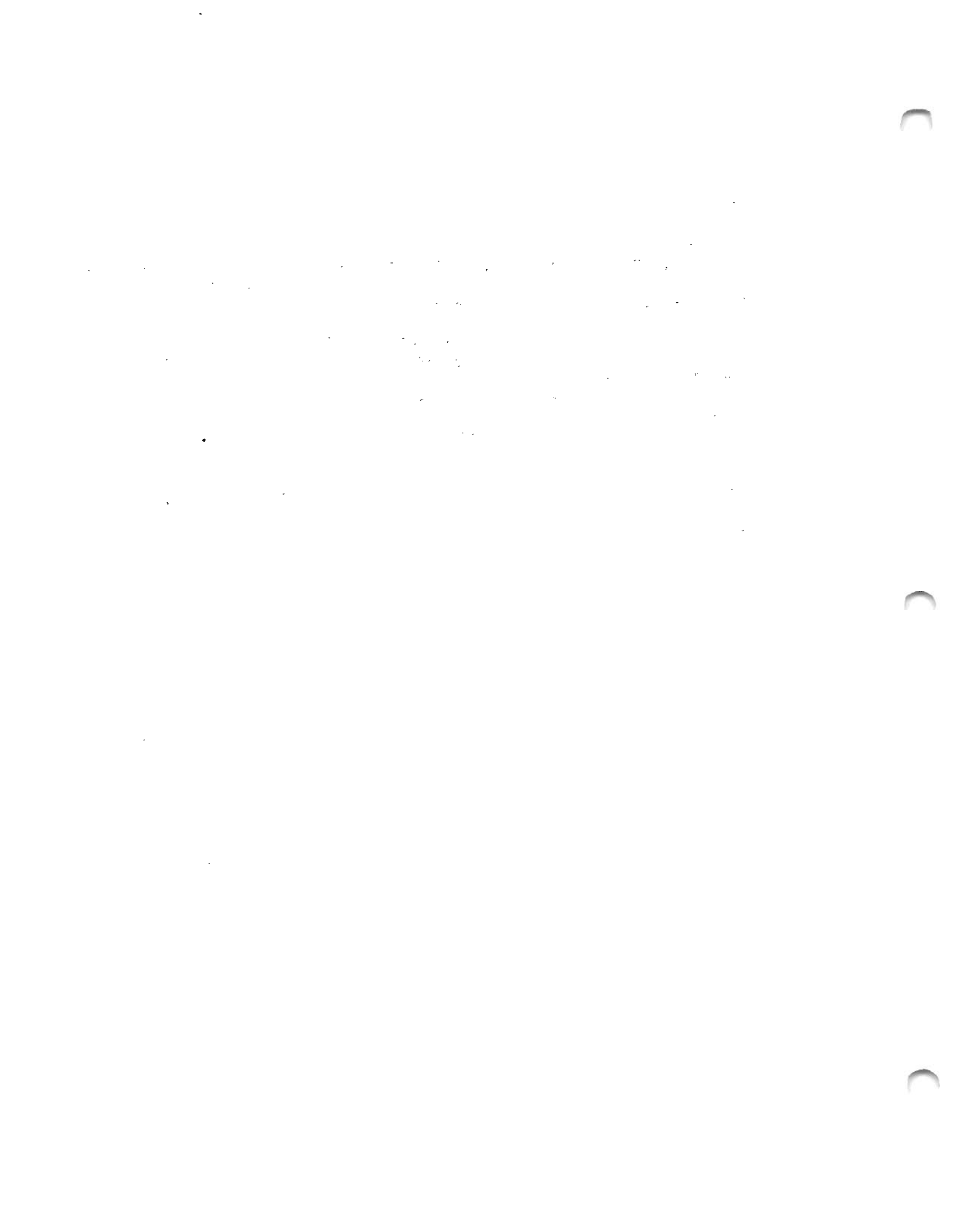

LVP/SVP

MASTER DISK AVAILABLE FOR 3 BOARD DPU ADJUSTMENT

Release 2.5 of the Basic-2 multi-user operating system for the LVP/MVP and the SVP with option W has been released for distribution. The diskette part numbers are as follows: 701-2294S (SSSD) and 731-0058B (DSDD).

Part number 731-0058B for DSDD drives has a unique data pattern on the innermost tracks for the phase lock loop adjustment. This data pattern can't be reproduced in the field. This diskette should never be formatted nor have another data pattern written to the innermost tracks. Should this happen or the diskette become non-operational a replacement diskette will have to be ordered.

This diskette is to be used as your "Master Disk" when adjusting the PLL on the 3 board DPU as described in the following procedure taken from District Newsletter # 25. There is a limited quantity of these disks in the Boston District. If needed immediately call Mike Bahia in the Boston office, Telephone # 423-2588, or otherwise order from Software Literature Control.

THREE BOARD DPU PLL ADJUSTMENT

To do a proper adjustment of the phase lock loop a PLL adjustment disk is needed, part # 732-0009A and a platter formatted on an aligned and properly adjusted drive with a worst case test pattern on it. This will be your master disk.

1. Ground TP1 of the 94 board and, while monitoring L5 pin 1 or 2, adjust the left most pot (connectors down, component side) for 4V. If system was in use, record previous voltage reading.
2. Load PLL adjustment program, insert master disk, select " Adjust Floppy," and adjust center pot midway between each end where it starts to error.
3. Once centered, let run for a full screen of dots.
4. Insert a good scratch disk, select number 5 and write worst case test pattern on floppy.
5. Select "Adjust Floppy" and again adjust center pot midway between each end where it starts to fail. If there is not at least one full turn between erroring points, there is something wrong and intermittent errors will probably result. One and a half turns or more is very good. Again, get a full screen of dots without errors.

THREE BOARD DPU PLL ADJUSTMENT, CONT'D

6. If 4 volts was off, the Quantum or Winchester should be formatted, then select SF 6 and write the worst case test pattern on the fixed. No data is disturbed by writing or verifying the worst case test pattern.
7. Select "Adjust Winchester" and center right most pot (connectors down, component side) between each end where errors start to occur. Must get at least one full error free turn and a full screen of dots. "Winchester," as referred to in the PLL program, is misleading as it really should say fixed because it will also work with a Quantum or fixed floppy.

** If these adjustments are found off all disks created by that drive should be reformatted. On every LVP and SVP installation, these adjustments should be checked or whenever experiencing disk errors.

IV.A.3 - 2200 SYSTEMS-MAINFRAMES-VP/MVP/LVP CPU'S.

TOPIC: MVP/LVP MUX "D" BOARD

As stated in District Newsletter #13 the combination of R7 proms with the 210-7591 Daughterboard may be causing a hanging problem with the system. Recent feedback indicates a more dominant symptom, ~~namely that the screens~~ ^{SCREENS} may be blanking out. The solution is to either downgrade the proms to R6 or downgrade the daughterboard to a 210-7291.

Area has informed us that you can now again order R6 proms.

It may have, however, been incorrectly stated that both the R7 proms and the daughterboard are needed to run WP with the 2236DW terminal. At one site, that was experiencing the blanking out problem, the proms were downgraded to R6 and the customer was able to run WP on the 2236DW terminal without any problems. Please have your ~~respect~~ customer test out his WP utility before you leave the customer's site if you have downgraded the MUX "D" board.

Thanks to Mike Genest of the Portland Office for his input into this problem

TOPIC: LVP MOLEX CONNECTORS

It has been found on several LVP systems that bad connections thru the Molex connector have been creating problems. The problem is a result of the female connection ^{OR} spreading and making poor contact with the male portion of the connector. This can be corrected by closing the female connector with a small pair of needle nose pliers. It is to your advantage to inspect and repair these connectors as it may save you time and problems at a future date

These connectors are used on the heat sink and to apply AC and DC to the internal disk drives.

Two of the problems that were experienced recently were:

1. No access to the Winchester Drive
2. Winchester head vibrates and the floppy drive light continually blinks with power on.

2200_LVE_Disk_Processing_Unit
 Z696_P.C.B._Configuration_switches

SWITCH_SW1_SETTINGS

	QEE	ON		
DIAGNOSTIC LEVEL		(*)	1	
(1004) 8 MEG.	(**)		2	4 MEG. (1002)
DIAGNOSTIC LEVEL		(*)	3	
(1002) 4 MEG.		(**)	4	8 MEG. (1004)
(NOT USED)	(SET TO ON)	()	5	(NOT USED)
FLOPPY	(***)		6	NO FLOPPY
(NOT USED)	(SET TO ON)	()	7	(NOT USED)
NO CERTIFY		(****)	8	CERTIFY

(*) For the present D.P.U. Power-Up Diagnostics, switches 1 & 3 must be in the ON position.

(**) Switches 2 & 4 indicate whether there is a 4 Meg., 8 Meg., or NO Fixed disk drive in the system.

NOTE 1:

Switches 2 & 4 both in the ON position is an ILLEGAL condition - ERROR_I91 will occur

NOTE 2:

Placing switches 2 & 4 both in the QEE position will inform the D.P.U. that there is NO Fixed disk drive. This is an effective means of disabling the Power Up diagnostic tests of the Fixed drive allowing the system to be brought up off the Floppy drive if the Fixed drive fails and there is not replacement drive available.

() Switches_5_A_Z are NOT used but, are normally set to the ON position.

(***) Switch_6 is used to inform the 7696 Microprocessor whether there is a Floppy Disk drive in the unit. ON - NO FLOPPY OFF - FLOPPY

NOTE:

Placing switch_6 in the ON position will tell the D.F.U. that there is NO Floppy disk drive. This is an effective means of disabling the Power Up diagnostic tests of the Floppy allowing the system to be brought up off the Fixed drive if the Floppy drive fails and there is not replacement drive available.

(****) Switch_8 is normally set to on to certify the Fixed disk during a format disk operation.

REASSIGNS BAD SECTORS
DURING FORMAT

IMPORTANT

If there is NOT an operational Floppy disk drive in the system or Switch 6 is not in the ON position indicating to the D.F.U. that there is NO Floppy in the system, the 2200 will not load the Operating System off of the Fixed Drive due to the detected failure.

This section explains the procedure for adjusting the phase-locked loop in the Disk Processing Unit (DPU). This adjustment should be checked whenever a disk read/write problem is suspected.

1. Check and adjust (if necessary) the CPU power supply voltages (ref: Section 11.2), and then turn the CPU ac power switch OFF.
2. Remove the cabinet top cover, and the CPU chassis cover (ref: Section 11.4).

NOTE:

Do not place the 210-7694 2200/Disk Interface board on an extender board when performing this adjustment.

3. Using a jumper wire, connect L8 pin 3 on the 210-7694 board to +0V (ref: FIGURE 11-2).
4. Connect the Channel 1 probe of the oscilloscope to L5 pin 1 or 2 on the 210-7694 board (ref: FIGURE 11-2).
5. Set the oscilloscope such that a +3.0V dc level can be observed. Be sure to ground the oscilloscope probe.
6. Turn potentiometers R7 and R8 on the 210-7694 board to their midrange points, and turn potentiometer R16 on the 210-7694 board fully counterclockwise (ref: FIGURE 11-2).
7. Turn the CPU ac power switch ON.
8. Adjust R16 until a +2.5V to +3.0V (preferably +3.0V) dc level is observed (ref: FIGURE 11-2A). Some oscillation (noise) may be noticed. Adjust R16 until the oscillation is minimized and the dc level is between +2.5V and +3.0V. (Lowering the dc level reduces the amount of oscillation.)
9. Carefully remove the jumper wire from L8 pin 3.

10. Connect the oscilloscope external trigger probe to S_2 (INDEX) on the 210-7594 board (ref: FIGURE 11-2). (S_2 can be reached on the circuit side of the motherboard.)

11. Set the oscilloscope as follows:
 - Trigger Source: External
 - Trigger Mode: Normal (DC)
 - Trigger Slope: Negative
 - Time Base: 100 usec/div
 - Vertical Sensitivity: 2V/cm
 - Input Coupling: DC
 - Ground Reference Point: Center Line

12. Insert an Operating System (O.S.) diskette into the DSDD drive, and depress RESET on the system console.

13. Depress SF'01 on the system console to load the O.S. from B10 (removable disk).

14. While watching the system console screen, adjust R8 until the "Loading BASIC-2" prompt is observed (if it is not already). Repeat steps 12 and 13 as needed.

15. If the O.S. will not completely load, fine tune R8 until a waveform similar to FIGURE 11-2F is observed. (Repeat steps 12 and 13 as needed.) FIGURES 11-2E and 11-2G show typical waveforms when R8 is turned too far counterclockwise (FIGURE 11-2E) or too far clockwise (FIGURE 11-2G).

NOTE:

It may be helpful to listen to the diskette retries (heads stepping back to track 0 on a reseek) while trying to load the O.S. By fine tuning R8 to reduce the number of retries, the O.S. should load. Continue adjusting R8 until the O.S. does load.

16. After the O.S. is loaded, remove the O.S. diskette, and enter the following program on the system console:

```
10 VERIFYF(X,X):PRINT".":GOTO 10
```

where X = 8127 if the the Fixed-Disk Drive is 2MB
= 16319 if the Fixed-Disk Drive is 4MB
= 32639 if the Fixed-Disk Drive is 8MB

17. Depress RETURN, RUN, RETURN to load and run the verify program. (The program verifies the last sector on the Fixed-Disk Drive, and prints a "period" on the system console when the operation is completed. An ERROR message will be displayed if a read error is detected.)
18. Adjust R7 until a waveform similar to FIGURE 11-2C is observed. Adjust R7 until noise is minimized, as in FIGURE 11-2C. FIGURES 11-2B and 11-2D show typical waveforms when R7 is turned too far counterclockwise (FIGURE 11-2B) or too far clockwise (FIGURE 11-2D).

NOTE:

If R7 is adjusted properly, FIGURE 11-2C will be observed, and the "periods" (.) from the verify program in step 16 will be displayed at a constant rate of speed. If R7 is turned in either direction (CW or CCW) until a verify ERROR occurs, either FIGURE 11-2B or 11-2D will be observed (dependent on direction). Watching the rate at which the "periods" (or the "ERRORs") are being displayed may help in setting R7 correctly. It may be helpful to purposefully create errors (by turning R7 to its extremes) in order to see what the waveform (noise) looks like when R7 is maladjusted.

19. When it appears that R7 is adjusted properly, change the oscilloscope Vertical Sensitivity to 1V/cm.

20. Carefully (slightly) turn R7 in both directions (CW and CCW) taking note of the exact amplitudes where the signal starts to become noisy. (There will be about a .6V difference between the amplitudes.) Adjust R7 such that the waveform amplitude is in the middle of this .6V range.
21. After R7 is set properly, verify the entire fixed disk to ensure complete operation of the DPU.

CAUTION:

If R7 appears to be adjusted properly (ref: FIGURE 11-2C), yet verify ERRORS still occur, the fixed-disk drive--or the disk sector that is being verified--is probably bad. Verify some other sectors on the fixed-disk to determine whether the drive or the platter is bad.

22. Insert a known-good, formatted diskette into the DSDD drive, and then enter the following program on the system console.

```
10 VERIFYR(3977,3977):PRINT".";:GOTO 10
```

23. Depress RETURN, RUN, RETURN to load and run the verify program. (The program verifies the last sector on the DSDD Diskette Drive, and prints a "period" on the system console when the operation is completed. An ERROR message will be displayed if a read error is detected.)
24. Set the oscilloscope Vertical Sensitivity to 2V/cm.
25. Adjust R8 until a wave form similar to FIGURE 11-2F is observed. Adjust R8 until noise on the waveform is slight, as in FIGURE 11-2F. FIGURES 11-2E and 11-2G show typical wave forms when R8 is turned too far counterclockwise (FIGURE 11-2E) or too far clockwise (FIGURE 11-2G). (It may be possible to adjust R8 such that a waveform that has less noise than the one shown in FIGURE 11-2F is obtained. However, errors may occur at this setting due to the fact that in order to obtain this "noiseless" waveform, the adjustment of the loop will actually be too close to the "noise limit"--the point where the clean waveform begins to break up).

NOTE:

If R8 is adjusted properly, FIGURE 11-2F will be observed, and the "periods" (.) from the verify program in step 22 will be displayed at a constant rate of speed. If R8 is turned in either direction (CW or CCW) until a verify ERROR occurs, either FIGURE 11-2E or 11-2G will be observed (dependent on direction). Watching the rate at which the "periods" (or the "ERRORS") are being displayed may help in setting R8 correctly. Again, it may be helpful to purposefully create errors (by turning R8 to its extremes) in order to see what the waveform (noise) looks like when R8 is maladjusted.

26. After R8 is set properly, verify the entire diskette to ensure complete operation of the DPU.

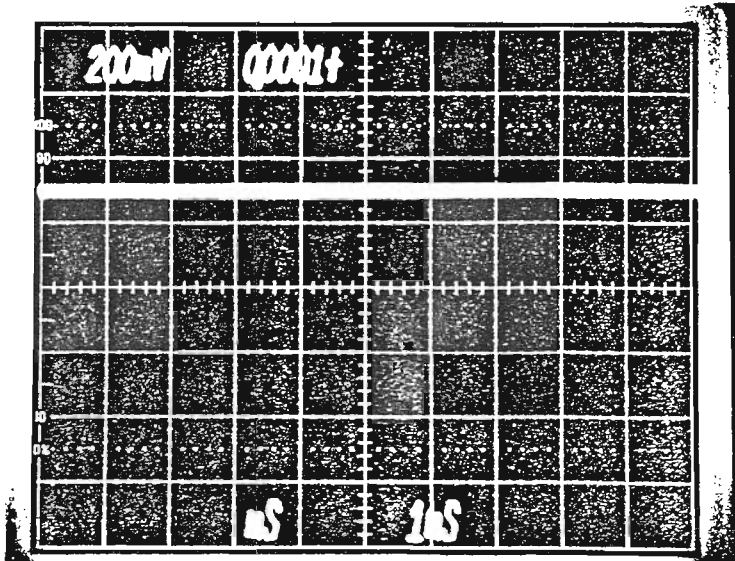

A

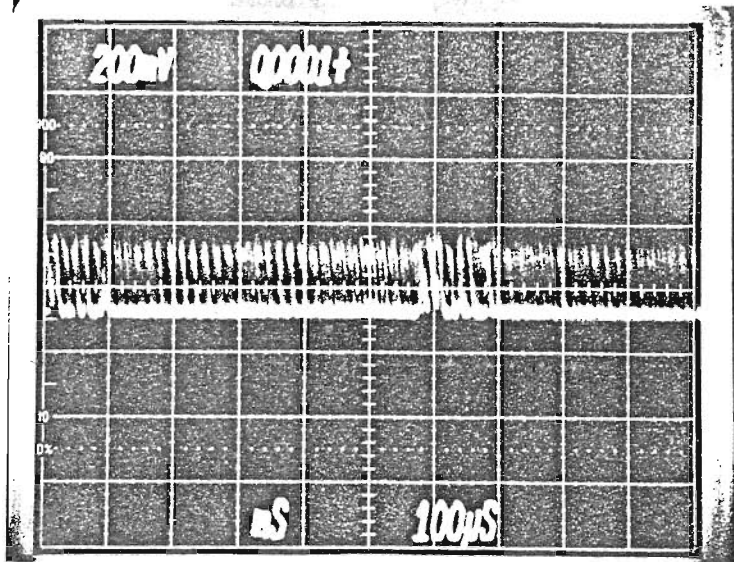

B

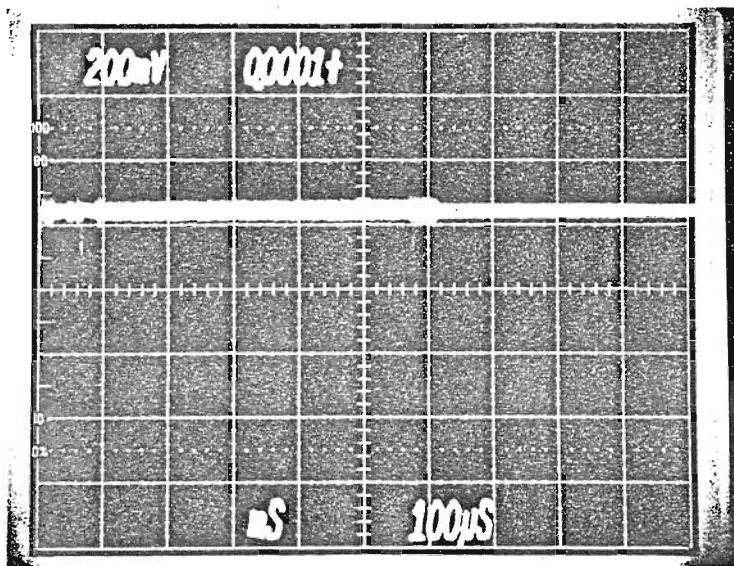

C

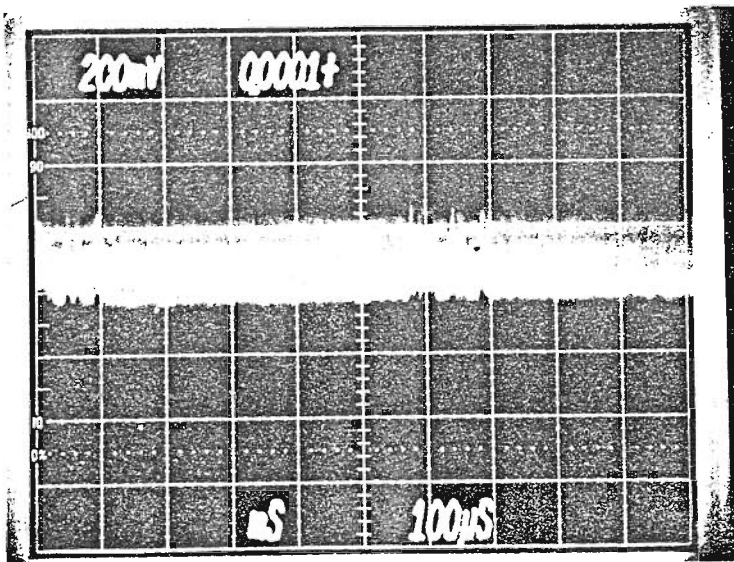

D

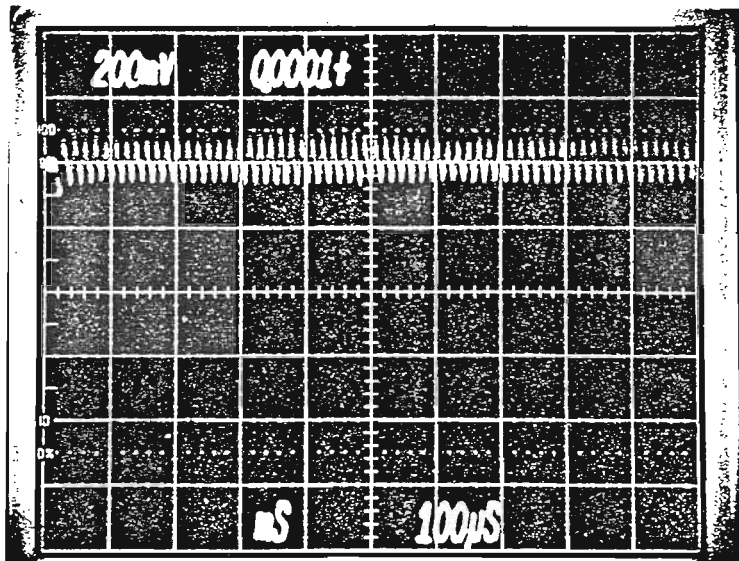
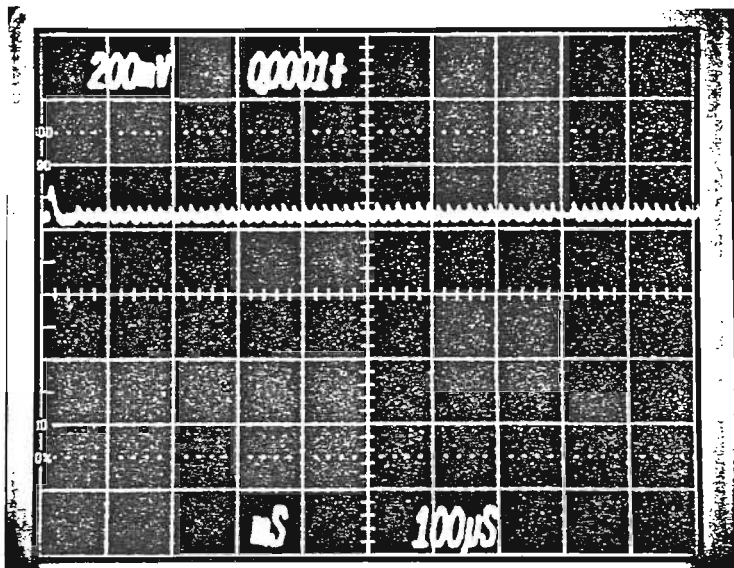
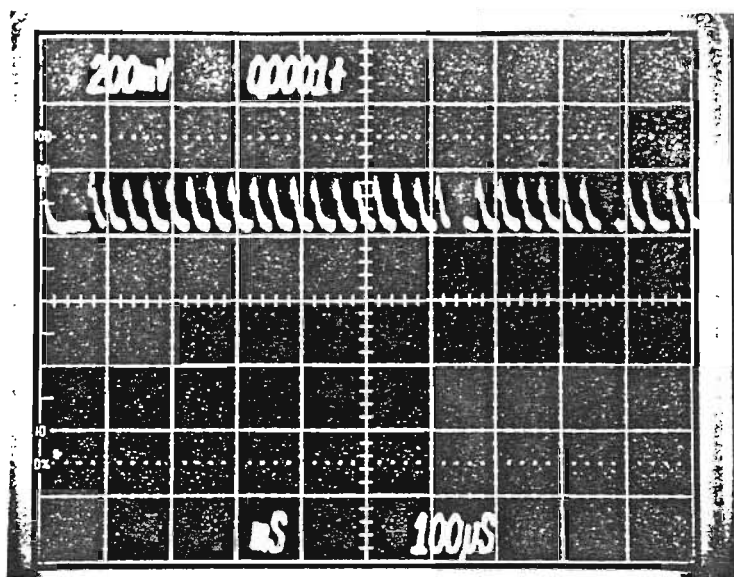

OUTER HEAD - SECTORS 0-25

I.

Index/Sector Adjustment

a. Insert Alignment Diskette (W.L.I. #726-1922).

b. Verify sector 60 (Track 1) on DSDD Floppy drive.

Example: 10 VERIFY T/B10(60,60): GOTO 10

c. Depress RESET.

d. Connect jumper lead from ground to point "C" on Disk Drive P.C.B. to load R/W Head.

e. Sync oscilloscope, external negative, on IP12 (-INDEX). Set time base to 50 μ sec/division.

f. Connect one probe to IP1 and the other to IP2. Ground probes to the P.C.B.. Set the inputs to AC. Add and invert channel B (2). Set vertical deflection to 500 mV/division.

g. Observe the timing between the start of the sweep and the data pulse. This should be 200 \pm or \pm 100 μ sec. If the timing is not within tolerance, continue on with the adjustment. Refer to Figure 1.

h. Loosen the holding screw in the Index Transducer until the transducer is just able to be moved.

i. Observe the timing, adjust the Transducer until the timing is 200 \pm or \pm 100 μ sec. Insure that the transducer assembly is against the registration surface on the base casting.

j. Tighten the holding screw.

k. Recheck the timing.

l. Verify sector 3960 (Track 76) and reverify that the timing is 200 \pm or \pm 100 μ sec.

Example: 20 VERIFY T/B10(3960,3960): GOTO 20

SINGLE DENSITY CYLINDER 0-26 SECTORS
DOUBLE DENSITY CYLINDER 1-52 SECTORS

TRK ϕ - SECTOR 10

TRK 1 - SECTOR 60

OUTER HEAD TRK 38 - SECTOR 2000

TRK 76 - SECTOR 3960

INNER HEAD TRK 2 - SECTOR 120

TRK 38 - SECTOR 2020

1 - 26 - 97
2 - 18 - 129

II.

Head Radial Alignment

- a. Insert Alignment Diskette (W.L.I. #726-1922).
- b. Verify sector 2000 (Track 38) on DSDD Floppy drive.

Example: 30 VERIFY T/B10(2000,2000): GOTO 30

- c. Depress RESET when R/W Head is at Track 38.
- d. Connect jumper lead from ground to point "C" on Disk Drive P.C.B. to load R/W Head.
- e. Sync oscilloscope, external negative, on IP12 (-INDEX). Set time base to 20 msec/division.
- f. Connect one probe to IP1 and the other to IP2. Ground probes to the P.C.B.. Set the inputs to AC. Add and invert channel B (2). Set vertical deflection to 100 mv/division.
- g. The amplitude of the lobes must be within 70% of each other. If the lobes do not fall within this specification continue on with the procedure (Refer to Figure 2).
- h. Loosen the two mounting screws, which hold the motor plate to the support bracket (refer to Figure 3).
- i. Move the plate, by rotating the eccentric adjusting screw.
- j. When the lobes are of equal amplitude, tighten the motor plate mounting screws (refer to Figure 2).
- k. Check the adjustment by stepping off track and returning. Check in both directions and readjust as required.
- l. Whenever the Head Radial Alignment has been adjusted the Track 00 detector adjustment must be checked. (Paragraph III)

III.

Track 00 Detector

- a. Check Head Radial Alignment and adjust if necessary before making this adjustment.
- b. Insert known QQQQ diskette
- c. Connect oscilloscope probe to IE26. Set vertical deflection to 1_v/division and sweep to continuous (Auto).
- d. Verify sector 60 (Track 1) on DSDD Floppy drive

Example: 50 VERIFY T/B10,(60,60): GOTO 50

- e. Depress RESET
- f. If IE26 is NOT high (+5V), loosen screw holding Track 00 detector assembly and move the assembly toward the spindle until TP26 goes high.
- g. Verify sector 120 (Track 2).

Example: 60 VERIFY T/B10,(120,120): GOTO 60

- h. Depress RESET. TP26 should go low (0V). Adjust the detector assembly toward the actuator assembly if TP26 is NOT low (0V).
- i. Check the adjustment by verify sectors 60 and 120 and checking to see that TP26 goes high at sector 60 and low at sector 120.

8/25/80 JRC

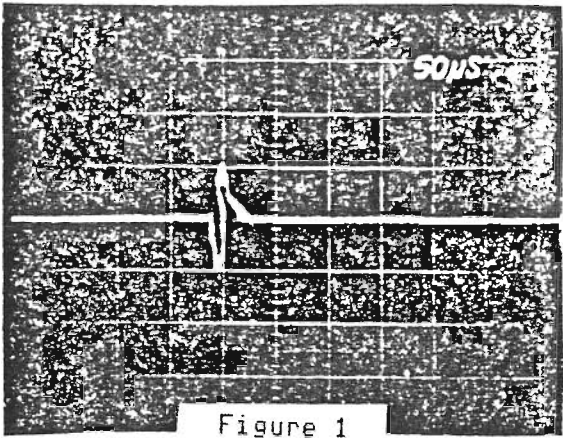

Figure 1

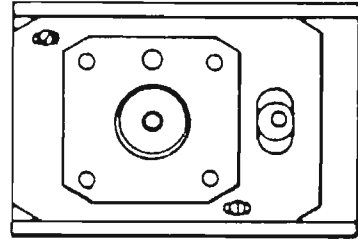
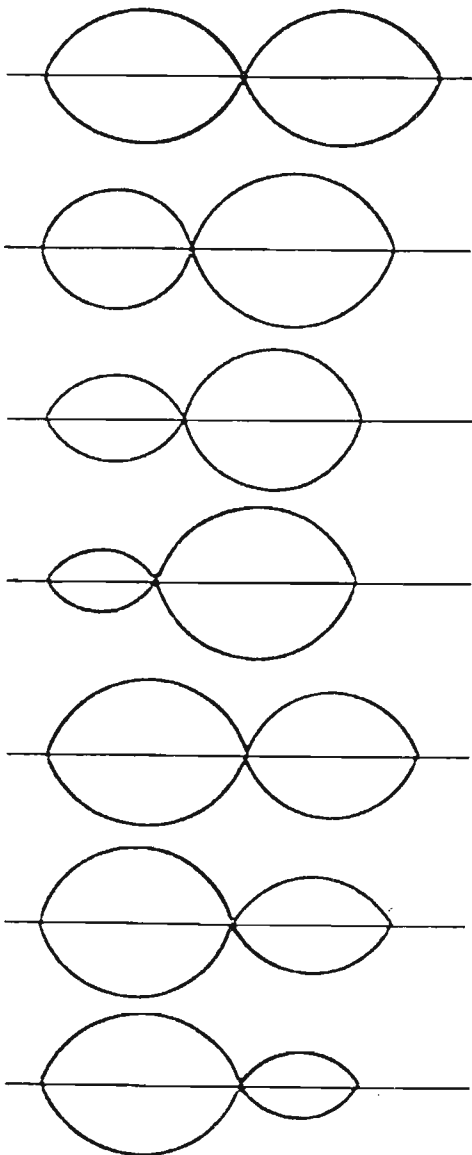

Figure 3 HEAD RADIAL ALIGNMENT



EVEN AMPLITUDE (100%), ON TRACK

LEFT 80% OF RIGHT, +1 MIL OFF TRACK TOWARD TK 0

LEFT 60% OF RIGHT, +2 MIL OFF TRACK TOWARD TK 0

LEFT 40% OF RIGHT + 3 MIL OFF TRACK TOWARD TK 0

RIGHT 80% OF LEFT, -1 MIL OFF TRACK TOWARD 76

RIGHT 60% OF LEFT, -2 MIL OFF TRACK TOWARD 76

RIGHT 40% OF LEFT, -3 MIL OFF TRACK TOWARD 76

Figure 2 HEAD RADIAL ALIGNMENT

Chet Kasprzak



LABORATORIES, INC.

RECEIVED BY

MEMORANDUM

APR 01 1982

CHET KASPRZAK

TO: Area Technical Operations Managers
FROM: Michael Riley
DEPT: 2200 Product Support
DATE: March 24, 1982
SUBJECT: A Partial Fix for the LVP's I-93 Problems

*KC
475
DMS
Bad Kinball
Mark McHale
Keith Toste
Mark Waller
FYI*

R & D has released three (3) ECO's that eliminate most of the I-93 problems plaguing the LVP's. These changes will cure about 80% of the problems and the other 20% require the new 210-7925 board.

ECO 21696 changes the Nanocode PROM (L1) on the 210-8695 and (L2) on the 210-7925 board. The PROM changes how the data is written on the disk and solves most of the Tom software problems.

ECO 21697 changes the max count time out to 128 from 160 on the 8694 and 8794. Working in conjunction with the Nanocode PROM, the reliability of the LVP is good.

The last ECO is 22452. This changes the firmware from R7 to R8. R7 PROMs have a known problem when trying to write over an alternate sector on a Shugart Winchester drive.

*John Forbes
Please identify
this
recurring
of L*

This is NOT the complete recommended fix for the LVP's I-93 problem. The 210-7925 board is required to make this fix 100% complete. For the next six months or so Logistics is going to keep the 210-7925 on restricted use. The ONLY way the field will be able to acquire the board is to open a TAC call and this will put the customer on the waiting list for the board. Spares will not be made available until all customers have reserved their DPU fix. If a customer has a problem with an installed 210-7925 board, a P-1 request with the customer name is required to get a new board. (Logistics is tracking shipment by customer name.)

Please do not order a 210-7925 board if you do not have a bad one to return. By using the system that was set up for you the customer's LVP problem will be fixed.

Regards,
Michael Riley
Michael Riley
Product Support Engineer

MR/ar/0097A

cc: Frank Andreano
Earl Emerick
John Bucsi

CUSTOMER ENGINEERING
TECHNICAL ASSISTANCE CENTER
NEWSLETTER

#20316

III.A.14

QUANTUM Q-2000 SERIES (8" WINCHESTER) DRIVES

TOPIC: GENERAL INFORMATION ON THE QUANTUM

The Quantum requires approximately 30 minutes to format one platter. The 32 Meg Quantum (Q-2040) has two platters, so to format both platters, it will require at least one hour.

The platters in the 32 Meg Quantum should be accessed in the same way as the platters are for the 2280 Phoenix. Select either D11 or D12 to access the individual platter. If the drive address (310, 320, etc.) is used for the 32 Meg Quantum, only one platter will be accessed, thus limiting you to 16 Meg of storage.

The Quantum drives that are being sent out ARE NOT FORMATTED and must be formatted before they can be used. Some drives may have 20 to 30 tracks formatted, but the drive must be re-formatted before the system can be released for customer use. Also note if the drive is a 32 Meg, both platters must be formatted.

TOPIC: 210-8696 SWITCH SETTINGS

The LVP-C uses the Quantum Winchester. The switch settings for the 210-8696 PCA are:

Switch Settings	#2	#4	#8	
	1	1	1	No Fixed Drive
	1	0	1	Small Fixed-
				210-8696-B = 2-Meg Shugart
				210-8696-A = 4-Meg Shugart
	0	1	1	8-Meg Fixed Shugart
	1	1	0	16-Meg Fixed Quantum
	0	1	0	32-Meg Fixed Quantum

Switch Number #6

1 = No Floppy installed

0 = Floppy installed

Switch Number #3 = OFF

All other switches should be in the 'ON' position.

(1 = ON; 0 = OFF)

CUSTOMER ENGINEERING
TECHNICAL ASSISTANCE CENTER
NEWSLETTER

#20309

IV.A.3

2200 SYSTEMS-MAINFRAMES-VP/MVP/LVP CPU'S.

TOPIC: MEMO ON 2200 OPTION C

Below is a reprint of a memo written by Gary Loper, ATS in the Central Area. The memo deals with information needed to properly install/service the 2200 option "C".

SUMMATION OF LVP OPTION C WITH QUANTUM DRIVES

1. For Data Memory greater than 256K, the 210-6793-1 must have ECO #17388 incorporated, bringing the E-Rev to 4.
2. The 210-6790 is replaced with a 210-7797.
3. A 210-7796 extended memory controller is installed between the Control Memory Boards and the Data Memory Boards.
4. If the Control Memory is not greater than 32K, (only one control memory board), it must be installed in the second slot. If it is installed in slot #1 a PECM 0001 FFFFFFF will result. (CM must be 64K for Cobol and Basic 3).
5. To run the Quantum Drives, ECO #20404D has been done on the LVP motherboard (7799). During installation refer to the TAC Newsletter #10292 for the Quantum shipping clamps and voltage checks.
6. The plus 5V2 volts I/O is now used for the last 4 I/O locations and can be measured at pin B of connector 1 at the I/O location.

Please become familiar with the PSN mentioned as soon as possible because many of these units are being shipped now and numerous other units are being upgraded.

If any questions arise, please don't hesitate to call.

CUSTOMER ENGINEERING
TECHNICAL ASSISTANCE CENTER
NEWSLETTER

#20615

IV.B.3

2200 SYSTEMS-INTERFACE-DISK MULTIPLEXER.

TOPIC: LVP/SVP DISK PROCESSING UNIT

The LVP/SVP has two DPU's in use in the field. The most common is the three board set 210-8694, 210-8696, and 210-7925, (replacing the 210-8695 in all new systems and in systems that have I-93/I-96 problems). This DPU is used in units that have a DSDD and a Winchester Drive.

The LVP option C with a Quantum Winchester Drive, requires a 210-8794 PCB. (Enables the access of the D12 platters on the 32M drive).

The PROMS on the 210-8696 board are to be upgraded to R8. They are available by FCO kit numbers 728-0013, (for the 210-8296A) and 278-0015, (for the 210-8296-B).

The 210-8694 must be upgraded to an E-REV 3 (ECO 21697). The depot repair centers are responsible for the upgrade.

The PLL adjustment (723-0009A Diskette) should be done any time I-93 or I-96 errors occur, and before the DPU is replaced.

The other DPU is the single board controller 210-7890, used in units that have only the DSDD diskette drives (one or two).

The LED is for power up diagnostic testing purposes. If the LED is lit the controller failed diagnostics.

The PROMS are to be upgraded to R2. They are available by FCO kit number 728-0012.

The 210-7890 controller sits in the same slot as the 210-8694 board.

CUSTOMER ENGINEERING
TECHNICAL ASSISTANCE CENTER
NEWSLETTER

#30111

III.A.14 (3108)

PERIPHERALS-DISK DRIVES-QUANTUM Q2000 SERIES 8"

TOPIC: QUANTUM DRIVE SELF DIAGNOSTICS

Any suspected drive can be exercised by the field engineer at the customer site. A drive that fails this test should be returned to the Repair Center.

Diagnostic Instructions:

CUSTOMER DRIVE CAN BE EXERCISED, DIAGNOSTIC WILL NOT DESTROY CUSTOMER INFORMATION. THE DIAGNOSTIC DOES NOT VERIFY THE R/W CIRCUITRY.

- Step #1: Disconnect the Wang cables connected to the drive in position J2 and J3.
- Step #2: Put jumper (E4) in place in the main PCB.
- Step #3: Turn Wang System "ON", drive uses the power for the logic and for the motor.

If the diagnostic jumper (E4) is in place the processor starts the diagnostic "seek program". This program commands the actuator to a seek pattern mode by using an internal track number register to monitor track position. The self-diagnostic implements an algorithm to access different tracks.

This pattern checks all possible length seeks plus checks for seek errors on every other seek (whenever the arm is at track zero).

CUSTOMER ENGINEERING
TECHNICAL ASSISTANCE CENTER
NEWSLETTER

#30111

III.A.14 (3108)

PERIPHERALS-DISK DRIVES-QUANTUM Q2000 SERIES 8"

TOPIC: QUANTUM DRIVE SELF DIAGNOSTICS (CONTINUED)

When an error occurs in the self-diagnostic mode, "READY" is dropped and the arm returns to the inner crash stop under spring power, media will continue rotating. The drive is left in this state until jumper E4 is removed. While E4 is still installed, an error code is latched in the 74LS374 at location 7E. The three least significant bits in this register are used to hold a binary-encoded error number. Five different error codes exist. These are:

Error Number	IC 7E			REASON FOR ERROR
	Pin 19	Pin 5	Pin 2	
1	0	0	1	No servos detected
2	0	1	0	Seek error in diagnostic (the micro processors internal cylinder address register does not agree with the track zero flag. Either track zero is present and the CAR is not zero, or the CAR is zero, but track zero is false).
3	0	1	1	No track crossing occurred in 15 ms during the slow speed seek mode.
4	1	0	0	No track crossing occurred in 2.5 ms during the high speed seek mode.
5	1	0	1	Drive did not seek to targeted track.

CUSTOMER ENGINEERING
TECHNICAL ASSISTANCE CENTER
NEWSLETTER

#30426

4103 (IV.A.3)

2200 SYSTEMS-MAINFRAMES-VP/MVP/LVP/SVP CPU'S.

TOPIC: GENERAL INFORMATION ON THE LVP/SVP DPU

The following information is being supplied in an attempt to keep the field updated on the latest microcode, and problem areas in the LVP/SVP DPU.

- 1) When doing the PLL adjustment on the 210-8696 PCA, you MUST have at least 1.5 turns on each pot (floppy & fixed) from error to error. This applies when doing the PLL to both the floppy and the fixed disk drives. If you cannot get 1.5 turns on both pots, the board should be returned as defective. Running the system with a PCA from which you cannot get 1.5 turns on both pots will result in intermittent I-93 errors.
- 2) The 2200 SVP/LVP DPU Microcode has been updated to revision R-9. When updating to R-9 Microcode, ORDER THE FCD KIT AND NOT THE INDIVIDUAL PROM'S.

The reason for change is:

- A. An I-93 error would occur when copying across an alternate sector on a Shugart Winchester Disk.
- B. The Data Processing Unit (DPU) would not pass power-up diagnostics when its switches were set to floppy only.
- C. The floppy door will unlock after 5 seconds of non-use.
- D. A format error found within the alternate sector during a FORMAT DISK operation is now recovered by the software.

The description of the changes are:

210-8696-A FCD kit # 728-0013-A

IC #	Location
378-4220-R9	L-29
378-4221-R9	L-28
378-4222-R9	L-27
* 378-4223-R9	L-26

210-8696-B FCD kit # 728-0015-A

IC #	Location
378-4220-R9	L-29
378-4221-R9	L-28
378-4222-R9	L-27
* 378-4230-R9	L-26

- * Please note that the PROM 378-4230-R9 is used only with the 2 Meg Winchester Drive. The PROM 378-4223-R9 is used with all other Winchester Drives.

CUSTOMER ENGINEERING
TECHNICAL ASSISTANCE CENTER
NEWSLETTER

#30426

4103 (IV.A.3)

2200 SYSTEMS-MAINFRAMES-VP/MVP/LVP/SVP CPU'S.

TOPIC: GENERAL INFORMATION ON THE LVP/SVP DPU (CONTINUED)

- 3) It has been reported that the 210-8696 DPU PCA has been shipped with the CPU chip at location L-30 being a Z80 chip and not a Z80-A. If you have an 2236 MXE controller which fails under heavy loads, check to insure the CPU chip is correct. If it is not a Z80-A, return the PCA as a defective board noting on the repair tag the problem.
- 4) The field has uncovered a problem using IBM formatted diskettes on an LVP. It seems a specific IBM disk format produces I-93 errors on the LVP and has only been seen using the 3741 option. The problem has been traced to a change in the way IBM formats each sector header.

To alleviate this problem, the customer should be certain he/she uses Wang "green label" diskettes. These diskettes have sector formats already on them. If reformatting is required, it must be done on the LVP. Any disk formatted on the 3741 system may cause I-93 errors on the LVP.

If problems arise where the customer is unable to live within these guidelines, please contact the area office with the customer's name, phone number, address and customer contact name. The Area will have the information forwarded to Corporate Customer relations for their direct dealing with the customer.

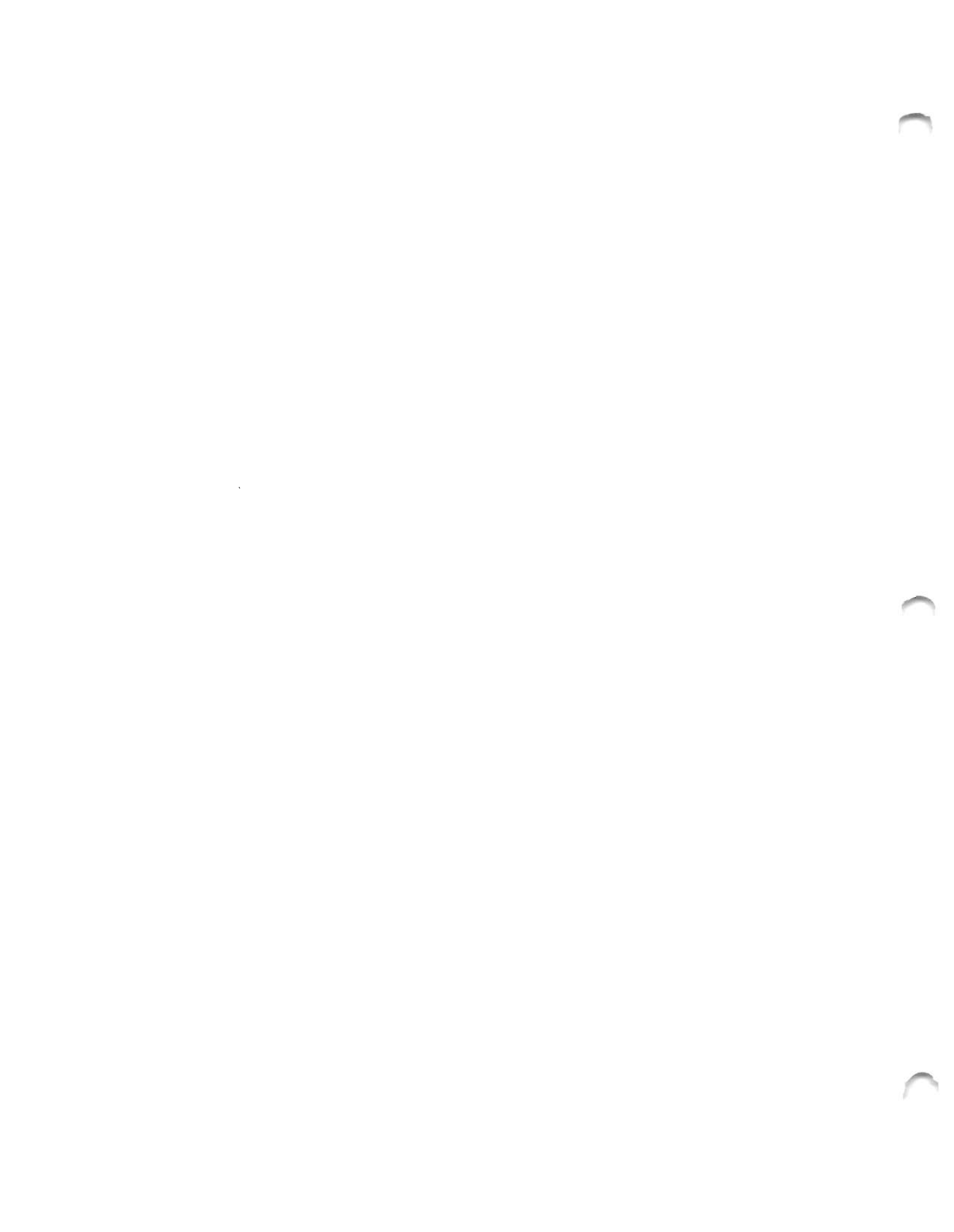

J. P. 110
DTS'S
DTS M.S.

BULLETIN

WANG

LABORATORIES, INC.

DATE: 4/19/84 ADMINISTRATIVE _____ TECHNICAL X NUMBER 245a

ORIGINATOR: Lattie Dean REVIEWED BY: John Howser

DISTRIBUTION: ATS X DTS/DTS X DM _____ ATOM X

ALL OFFICES X HOME OFFICE X EACH EMPLOYEE _____

SUBJECT: LVP/MVP System Check List PAGE 1 OF 4

/CAT 4103

This Bulletin supercedes Area Bulletin #245.
LVP/MVP SYSTEM CHECK LIST

RECEIVED

ON AN ESCALATION
ALWAYS REVIEW THE CUSTOMER FILE

APR 25 1984

1.

PCB's must be updated to current E Rev.

PCB #	Current E Rev	Must be at Least	Comments
210-6787-1	1	1	Old Data Memory
2106788	2	2	Old Control Memory
210-6797	3	2	Old Style Regulator
210-6789	0	0	R5 Proms
210-6791	3	3	DO NOT USE ON MVPC/LVPC
210-6790	7	6	
210-6791-1	0	0	Use-1, only 3rd row up chip 2-5 from left must be fairchild
210-6792	5	4	
210-6793-1	4	3	Must be E Rev 4 for expanded memory
210-7397	7	7	New type MVP/Reg
210-7397-1	2	2	Special, for use with old VP/MVP Chas.
210-6798	4	2	Need Rev 4 for 16K Ram
210-7587	1	1	
210-7588	3	3	
210-7588-1	3	3	
210-7887	7	7	SVP
210-7789A	3	3	SVP
210-7890	4	4	
210-7697	7	7	LVP Regulator
210-7797	0	0	LVPC/MVPC's EXT I/C COUNTER
210-7796	1	1	LVPC/MVPC's EXT MEM CONTROLLER
210-7925	2	2	LVP/SVP
210-8696A	0	0	R9 Proms
210-8694	3	3	LVP/SVP
210-8794	2	2	LVP/SVP
270-0467			LVPC CHASSIS OLD
270-0471			LVPC CHASSIS NEW
270-0889			LVPC POWER SUPPLY NEW ORDER
270-0616			FOR ALL LVP POWER SUPPLY OLD FOR LVP CHASSIS
270-0617			LVP POWER SUPPLY OLD FOR LVPC CHASSIS

210-7397 - There is a preliminary ECN to this regulator to raise the foldback point of the 12 Volt P/S.

Change R37 to 2.2K Pin 11 L9

Change C20 to 1 uf Pin 9 L9

THIS IS NOW STANDARD IN E REV 7 PCB'S

- X 2. On MVP's, the MXE's and MXD's must be installed next to the CPU. Change the fan over the I/O to a 400-1001 if more than 2 large controllers are installed. See TAC NL 30125, Section IV.A.3. Drill or knockout the old mounting so the fan will be as close to the frame as possible. NOTE: the xcelite 7/32 socket and handle placed off the stud will make the removal very easy.
3. On the LVPC, replace both fans with 400-1029.
4. Verify that the shields are connected on both ends of the RS232 cables. This shield must be grounded at the Terminal and the CPU Controller.
- X 5. Static proof all 2236D and 2236DE Terminals. A heavy duty staple gun and 1/4 inch uncoated staple makes for a much better job. The screws for the RS232 cable must be tight on both ends.
6. 2236DE's and DW's must be verified for all updates. The current Prom level for the 270-0753, 270-0817 is R5's.

2336DE
L9 - 6013 R5
L10 - 6079 R5

2336DW
L9 - 6013 R5
L10 - 6014 R5

2336DE
2336DW

210-7743C ,order # 270-0817
210-7743A ,order # 270-0753

The power supply in the 2336 is a high failure item. Do not overlook the P/S for intermittent problems isolated to one terminal.

7. On the MVP \pm 0 Volts should be tied to chassis ground.
- X 8. Verify with a scope that the LVP power supply ripple is within specification. See Atlanta Bulletin #237.
9. All cables must be tight at both the controller and device. Printers and 2280 DPU cables must be updated to a 220-0105-3. This cable has better shielding and has more noise immunity.
10. The MXD must be updated with the 2 caps if it has a 7591 Daughter board. See FOO 1035.
- 10a. THE MXE PCB 210-7874 MUST BE A E REV 1 EOO227550
11. The 2280 Phoenix must have the shielded DPU cables installed and the line filter installed in the DPU.

12. The DPU must be checked for ripple with a scope. The 20V 6000 uf caps are a high failure item.
13. The 2280 DPU E Rev's are:

	<u>E Rev</u>	<u>Comment</u>
210-7416	2	M.B
210-7421	3	
210-7422	4	
210-7423	4	R7 Prom (R8's are in beta testing)
210-7424	9	
210-7415	0	
210-7715	6	MUX
210-7717	2	MUX
210-7718	1	MUX

If a phoenix is the last drive in a chain, perform F00 1024A.

14. If there is a mag tape, the I/O cable must be grounded at the CPU and the tape unit. A 2280 DPU cable clamp with a short piece of wire can be used to ground it at the CPU to a controller thumbscrew.
15. On MVP's, verify that the 2 power transistors on the heat sink are 375-1072(2N5685), and not a 375-1048 (2N5301).
16. If there is a Band Printer then both the static kit (part #728-0006, PSN 111C10-4) and the cover latch kit (part #726-1702, refer to TAC NL 20209, Section III.C.10) must be installed if needed.
17. On MXD's verify continuity of Port 2 Pin 7 to the other 3 Ports. Should boards be missing a jumper to Pin 7 Port 2, it will cause intermittent problems on Port 2 only.
18. Anodized controller rails should be cleaned to insure good contact when thumb screws are tightened.
19. Chassis ground on 2236MXD not secure should go to Pin M, Section 3 to rail and RS232 Pin. (Active not resolved).
20. Pin 11, Section 3 of I/O section on LVP's not connected to chassis ground. (Active not resolved).
21. On LVP's the reference voltage on the 210-8694, 8794 must be set to exactly 4 Volts (WITH TP1 GROUNDED) with a range of at least 1 1/2 turns on the floppy and winchester VCO Pot.
22. Some MVPC update kits were shipped without the longer card support bracket to support the additional cards in a MVPC. The part number for this bracket is 270-0732. This bracket should be installed on the "next call", on any MVPC that does not already have it installed.

23. Some LVPC'S have been found to have the hot and neutral wire reversed in the power supply 270-0617. This can be verified at the A/C power cord for the Floppy or Winchester Drive.
24. On a MVP adjust the 12 volts for 12.1 volts measured at the controller the farthest from the power supply. Failure to do this could result in PEOM'S, PEDM'S and other intermittent problems.
25. Check lights and other intermittent problems on I/O devices can be caused by bad voltages in the CPU, always check voltages.
26. Always check ground rec on the wall for all devices.
27. Always install the latest release of VP/MVP software if working with a mystery problem.
28. A 44B track zero can be fine adjusted by the air filter screws. It is a good idea to check the track zero before and after changing a filter in the 44B.
29. A new LVP fan part number 400-1029 is about 1 inch thick. This fan is needed if you have a problem with a fan hitting the MXE. - FCO 1046
30. Don't forget there still are a lot of chassis in the field that have bad connectors.
31. Heat problem on LCP/LVPC? Make sure that the baffle is installed at the bottom of the front panel and foam rubber strip mounted under the chassis.

2200LVP

Listing of Catalog of Previous Diskette After Change Drives

Solution to this problem is to insure winchester is terminated,
not floppy, and that DC jumper on floppy is in.

M-E-M-O-R-A-N-D-U-M

TO: All Northeast Area DTS's

FROM: John Forbes

DATE: April 21, 1983

SUBJECT: IBM Diskette Usage On LVP

A problem has been found using IBM formatted disks on an LVP. Apparently certain IBM disk formats produce I-93 errors on the LVP when using the 3741 option. The cause was traced to a change in the way IBM formats each sector header.

To prevent or cure this problem, ensure that the customers use Wang green label diskettes. These diskettes have sector formats already on them. If reformatting is required, it must be done on the LVP. Any disk formatted on the 3741 system may cause I-93 errors on the LVP.

If problems arise where there is no way possible for the customer to live within these guidelines, please contact me with the customer's phone number, address and customer contact name. This information will be passed along to Frank Andreano, who will contact Customer Relations.

Any questions, please call.

Regards,

John Forbes
Area Technical Specialist

JF:0012L

BASIC-2 OPERATING SYSTEM RELEASE ANNOUNCEMENT

by 2200 R&D

BASIC-2 Release 2.5

All 2200 VP/SVP single-user systems should be updated to Release 2.5 of the single-user Operating System.

Diskette numbers are: 701-21180 for VP
701-0001C for SVP
701-8068G for minidiskettes
701-8069F "
701-8129B "

Corrected Anomalies

In the editor, a problem relating to pressing the ERASE key at the end of a LINPUT field has been corrected.

In the editor, a problem relating to recalling text lines while in non-edit mode on a 2236DW terminal has been corrected.

A problem with the INPUT statement has been corrected. Attempting to supply a value enclosed by quotes in response to an INPUT request would result in an error X73. Also, not supplying values for all variables in the INPUT statement variable list would occasionally result in an error X75.

Changes and Corrections - Release 2.4 to 2.5

@DAVFU The documentation displayed at the beginning of the utility has been changed to show the correct loading sequence for all VFU files created by the utility.

@MOVEFIL All keyboard entries have been made case-insensitive; entering lower case replies will no longer result in an incorrect response from the utility.

@BACKUP An erroneous message concerning the @BADSCTR file has been corrected.

@FORMAT The program has been changed to control the occurrence of all disk errors and to erase the 15 second message on the terminal correctly.

Diagnostics

The '@-backslash' file as well as '@A' diagnostic have been updated. They were made to update the field service diagnostic and to fix a problem with the cpu diagnostic.

BASIC-2 Release 2.3

Release 2.3 of the BASIC-2 Multi-Task Operating System has been issued to provide support for the additional memory banks available on the 2200MVPC and 2200LVPC units. Release 2.3 can run on 2200MVP, 2200LVP and 2200SVP as well. Release 2.3 includes the following features and enhancements to earlier versions of the operating system:

The operating system now provides up to 512K bytes of user memory available for 2200MVPC and 2200LVPC systems. The maximum number to terminals remains 13 and maximum number of partitions is still 16.

The Partition Generator (@GENPART) and Partition Status (@PSTAT) System Utilities now support 512K of memory.

Revised system diagnostics for testing control and user memory are provided.

Corrected Anomalies

On earlier versions of the operating system, the DSKIP and DBACKSPACE statements, specifying a number of sectors or BEG could cause Model 2230MXA/MXB Disk Multiplexer to enter "hog" mode, thus locking out other CPU's. These statements have been corrected for Release 2.3 to enable the disk controller only when it is necessary to read the disk.

User's who utilize \$GIO to "hog" and "unhog" the disk are cautioned that a similar problem may occur in their programs if the "unhog" command (CBS 00) is issued without waiting for READY. All user's are encouraged to utilize the \$OPEN and \$CLOSE statements when exclusive control of any device is required.

Changes to the System Platter

The following files have been changed since Release 2.2 . The purpose and operation of each utility remains the same:

@MVP	MVP Operating System and BASIC-2 Language Processor (Release 2.3)
@A	CPU Diagnostic
@B	Control Memory Diagnostic
@C	Data Memory Diagnostic
@-backslash	Field Service Diagnostics Menu
@P	User Diagnostics Menu
@GENPART	Partition Generator Utility
@PSTAT	Partition Status Utility
@INSTALL	System Installation Utility
@SYSFILE	System Configuration File

WANG

TECHNICAL SERVICE BULLETIN
SECTION: SoftWare Technical

NUMBER: SWT 5108 REPLACES: _____ DATE: 08/27/85 PAGE 1 OF 1
MATRIX ID. 4306 PRODUCT/RELEASE# 2200 IDEAS2/2.4
TITLE: Elimination of P56 error while running reports in IDEAS2.

PURPOSE:

To correct a problem with IDEAS2 in which an application could fail with a P56 error at line 418 in the IDEAS2 subroutines while running a report.

EXPLANATION:

When an IDEAS2 report finishes running, it first checks the key buffer for each of the files used in the report to make sure that no record has been left protected. If there is a discrepancy between the number of files listed in the application START program, and the number of files actually opened in the application, the P56 will occur when IDEAS2 checks the key buffer.

CORRECTIVE ACTION:

In IDEAS2 module IDS2SUB1, the fourth statement on line 418 is 'FOR V=1 TO LEN(E1\$())/56'. This statement should be changed to 'FOR V=1 TO LEN(STR(F1\$())/LEN(STR(F1\$(1))))'.

NUMBER: SWT 5109 REPLACES: _____ DATE: 08/27/85 PAGE 1 OF 1
MATRIX ID. 4306 PRODUCT/RELEASE# 2200 IDEAS2/2.4
TITLE: Eliminating extraneous STOP statement in IDEAS2 report driver

PURPOSE:

To inform the field about a STOP statement in IDEAS2 that is encountered when running an IDEAS2 report that uses level breaks.

EXPLANATION:

In release 2.4 of IDEAS2 there is a STOP statement that causes reports using level breaks to stop executing. The circumvention is to key 'CONTINUE', then 'RETURN', at which time the report will proceed.

CORRECTIVE ACTION:

Remove the STOP statement from line 1815 in IDEAS2 module IDS2PBX4.

GROUP: VS/2200 Software Support MAIL STOP: 0121A

COMPANY CONFIDENTIAL
WANG Laboratories, Inc.

TECHNICAL SERVICE BULLETIN
SECTION: SoftWare Technical

NUMBER: SWT 5106 REPLACES: _____ DATE: 08/27/85 PAGE 1 OF 1
MATRIX ID. 4335 PRODUCT/RELEASE# DATAMERGE 2.2
TITLE: 2200 DATAMERGE P56 ERROR CORRECTION

PURPOSE:

To correct a P56 ERROR which occurs in DATAMERGE record selection with some IDEAS 1 files.

EXPLANATION:

With some IDEAS 1 files DATAMERGE 2.2 will abnormally end with a P56 ERROR in line 4270 during record selection. To correct this problem, line number 4460 of the DATAMERGE program "LPIDSUBS" should be changed:

OLD:4460:::::IF D3[=C6 THEN 4480

NEW:4460:::::IF D3[C6 THEN 4480

where [is used to represent the "less than" symbol available in 2200 BASIC 2.

GROUP: VS/2200 Software Support MAIL STOP: 0115

COMPANY CONFIDENTIAL

WANG Laboratories, Inc.

CUSTOMER ENGINEERING
TECHNICAL ASSISTANCE CENTER
NEWSLETTER

#40605

3108

PERIPHERALS-DISK DRIVES-QUANTUM

TOPIC: NEW ACTUATOR LOCK IN THE QUANTUM 2000

An improvement has been made to the actuator lock to eliminate any possibility of the lock unlocking during high shock and vibration situations, specifically during shipment. The lock has also been changed to make it easier to turn. This will lower the risk of damage to the turn slot. A change in the procedure for unlocking the actuator is required. The new procedure is as follows:

1. Loosen the "lock screw" (a quarter turn should be sufficient).
2. Use the "turn slot" to rotate the lock to the unlocked position.
3. Tighten the lock screw.

Reverse the procedure to lock the actuator.

If the main turn slot is damaged the optional turn slot can be used to lock and unlock the drive.

1. Lock screw is located in the outside of the Actuator Lock.
2. Turn slot is the screw located in the center of the Actuator Lock.
3. Optional turn slot is a small rectangular hole located vertically from the turn slot.

CUSTOMER ENGINEERING
TECHNICAL ASSISTANCE CENTER
NEWSLETTER

#01007

IV.C.4

2200 SYSTEMS-SOFTWARE-OPERATING SYSTEMS

TOPIC: MVP/LVP OPERATING SYSTEM RELEASE 2.1

Release 2.1 of MVP/LVP Operating System is now available. Corrected anomalies are as follows:

1. If reset was pressed while a disk operation was in progress for that partition, error I-90 could result on a second partition that was waiting to access that disk.
2. Attempting to execute the MAX function of an alpha array did not generate an error.
3. A system crash could occur due to the illegal use of trailing minus signs in the PACK statement image if other programs were running in other partitions. The system inadvertently allowed the illegal syntax.
4. The Partition Status Utility, @PSTAT, could occasionally erroneously display the bank separation lines.
5. The Format Disk Platter Utility, @FORMAT, did not release (\$CLOSE) the disk after formatting.
6. The 2273 Vertical Format Control Utility, @2273VFU, did not treat bottom of form properly. The BOF was specified at the last printed line; but in fact, no data can be printed at the BOF line. BOF is now specified after the last line to be printed and can be omitted if there is not bottom of form skipover.

System Enhancements

1. MVP Basic-2 now supports the 2200 LVP as well as the 2200 MVP hardware.
2. The following new utilities are provided: @BACKUP, @RECOVER and @MOVEFIL.

ANG

LABORATORIES, INC.

CUSTOMER ENGINEERING
TECHNICAL ASSISTANCE CENTER
NEWSLETTER

#01125

A.3

2200 SYSTEMS-MAINFRAMES-VP/MVP/LVP CPU'S.

TOPIC: 2200 LVP/SVP WINCHESTER DISK/DSDO DISKETTE PROCESSING
UNIT.

LOGIC BOARDS: WL #210-7694
WL #210-7695-A
WL #210-7696-A (-B)

Extensive modifications have been made to the three DFU boards to correct all known problems.

Logistical Information

The DFU boards presently in use are functionally satisfactory. However, R & D has been able to provide several enhancements.

To facilitate the updating of existing 2200 LVP units, the Logistics Department is developing a DFU "swap" procedure. Basically, a set (one for each customer and/or field unit supported) of completely updated DFU boards will be sent to Branch Offices now supporting 2200 LVP units -- the old boards will be returned to the Home Office. When the Logistics Department finalizes the "swap" procedure, they will supply each Branch Office concerned with the exact details. DO NOT CALL THE LOGISTICS DEPARTMENT CONCERNING THIS MATTER!

All newly manufactured 2200 LVP units (i.e., shipped after 11/18/80) will contain the updated DFU boards.

Technical Information

The E-Rev levels of the updated boards have been set back to "1".

In the future, the ECN's will be incorporated into the artwork.

The following chart explains the loadings for the 7696.

7696-A

7696-B

L29 378-4220-R05	378-4220-R05
L28 378-4221-R05	378-4221-R05
L27 378-4222-R05	378-4222-R05
L26 378-4223-R05	378-4230-R05

ANG

LABORATORIES, INC.

CUSTOMER ENGINEERING
TECHNICAL ASSISTANCE CENTER
NEWSLETTER

#01125

A.3

2200 SYSTEMS-MAINFRAMES-VP/MVP/LVP CPU'S. (Continued)

TOPIC: 2200_LVP/SVP_WINCHESTER_DISK/DSDD_DISKETTE_PROCESSING
UNIT.

The following chart explains the loading for the 7695.

7695-A

L01 378-4224-R00
L02 378-4225-R00
L03 378-2560-R01

The R numbers are for this date only; the latest (highest)
R numbers should be used.

With these latest ECN's incorporated:

- Switch 3 of switchbank SW1 on the WL #210-7696-A (-B) board must be set DEF
- The total available sectors on the DSDD Diskette Drive is 3874 (sector addresses 0-3873). (Marketing Support will notify customers of this change.)
- Formatting time for the Winchester Disk Drive is approximately 13 minutes.
- Formatting time for the DSDD Diskette Drive is approximately 2 minutes.
- The PLD adjustment is no longer required. The potentiometers will be glyptolled after the adjustment has been performed in Manufacturing.

ANG

LABORATORIES, INC.

CUSTOMER ENGINEERING
TECHNICAL ASSISTANCE CENTER
NEWSLETTER

#01125

A.3
2200 SYSTEMS-MAINFRAMES-VP/MVP/LVP CPU'S.

TOPIC: MINIMIZING LVP DOWNTIME

Error indication:

Flashing light on floppy door.

- a.) Replace 96 card in CPU section
- b.) Replace 6793 card in CPU section

Error indication:

I93 or I96 from the fixed drive.

- a.) Replace 94 card in DPU section
- b.) Replace 95 card in DPU section
- c.) Replace fixed drive

Error indication:

I93 or I96 from floppy drive.

- a.) Replace media
- b.) Replace 94 card in the DPU section
- c.) Replace 95 card in the DPU section
- d.) Replace floppy drive

NOTE: Before any tests are run, switch settings (96)
and voltages should be checked.

CUSTOMER ENGINEERING
TECHNICAL ASSISTANCE CENTER
NEWSLETTER

#01216

IV.A.3

2200 SYSTEMS-MAINFRAMES-VP/MVP/LVP CPU'S.

TOPIC: 210-7696A & B

In reference to TAC Newsletter #00909, the part numbers for PC board 7696 are as follows depending on PROM loading.

PCB 210-7696-A

L29-378-4220 R (xx)
L28-378-4221 R (xx)
L27-378-4222 R (xx)
L26-378-4223 R (xx)

Use this configuration
for 4 or 8 MB Winchester
Drive LVP.

PCB 210-7696-B

L29-378-4220 R (xx)
L28-378-4221 R (xx)
L27-378-4222 R (xx)
L26-378-4230 R (xx)

Use this configuration
for 2 or 8 MB Winchester
Disk Drive LVP.

The 210-7696-A PCB can be changed to 210-7696-B or vice versa by changing PROM at location L26 with PROM part number described above. Care must be exercised when PROM is taken out and inserted in socket so as not to bend the pin or insert PROM upside down.

CUSTOMER ENGINEERING
TECHNICAL ASSISTANCE CENTER
NEWSLETTER

#10113

III.A.12

PERIPHERALS-DISK DRIVES-SHUGART SA-1000 8" WINCHESTER

TOPIC: ERRORS ON WINCHESTER DRIVES USED ON LVP - ECO.

If you are experiencing I-93 errors or format errors on the winchester drives, 278-4013 (-1 50 Hz), 278-4014 (-1 50 Hz) add an 820pf ceramic disk capacitor (WLI P/N 300-1820) in parallel with R83 (6.2K) on the control circuit board (larger board) between chip 7A₂ (LM311) and chip 8A (7438), approximate board coordinates 8A.

The capacitor should be adequately mechanically secured to the resistor lead (wrap capacitor leads around resistor leads) then solder together.

This ECO should also be done to all winchester drives in stock and drive PCB's (726-1902) before installing in systems.

The ECO should be done immediately to all winchester drives and PCB's in stock, and on a next-call basis or as required in the field.

This ECO eliminates noise on the trailing edge of the comparator output pulse, which in turn eliminates an undesired second index pulse from one shot 96LS02.

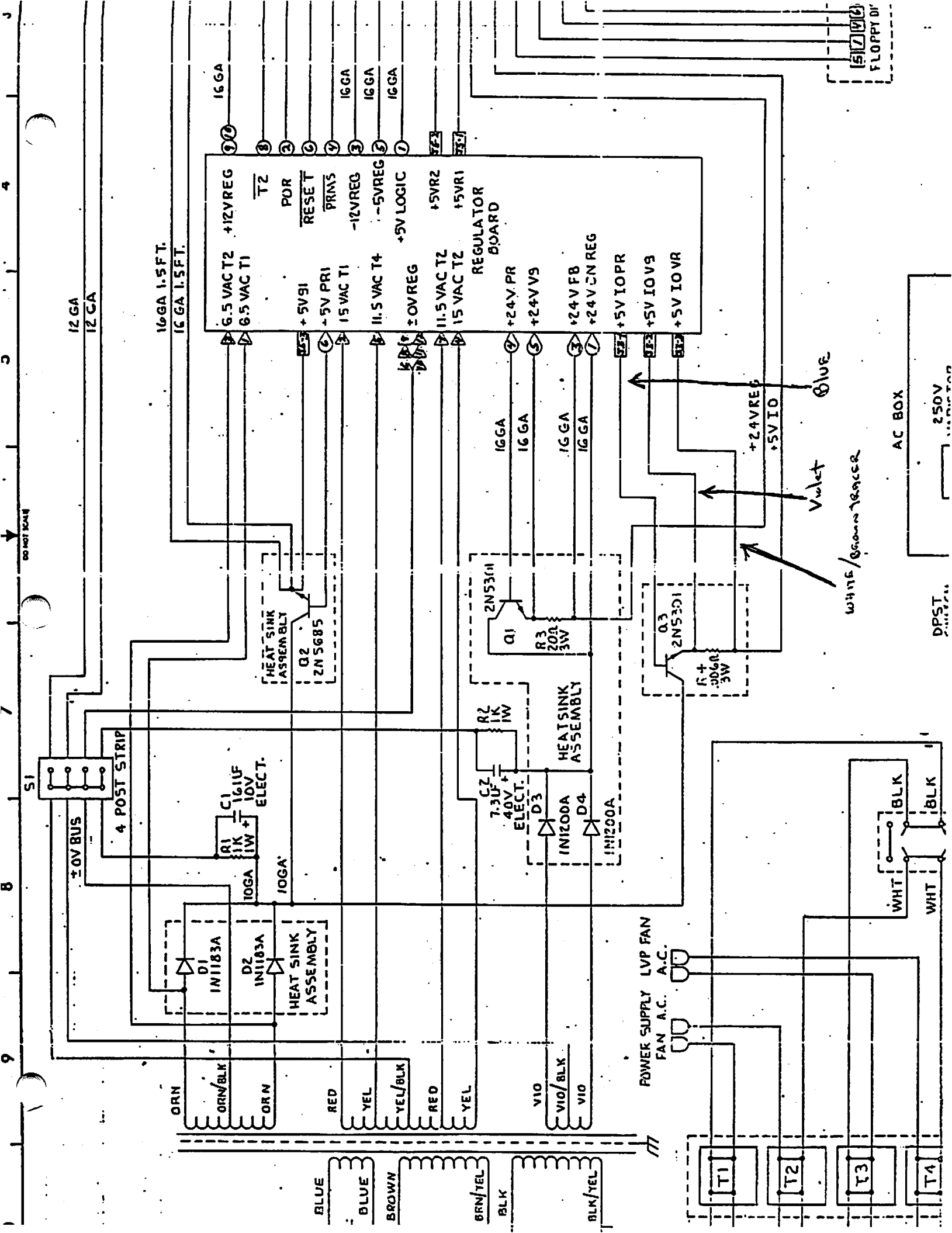

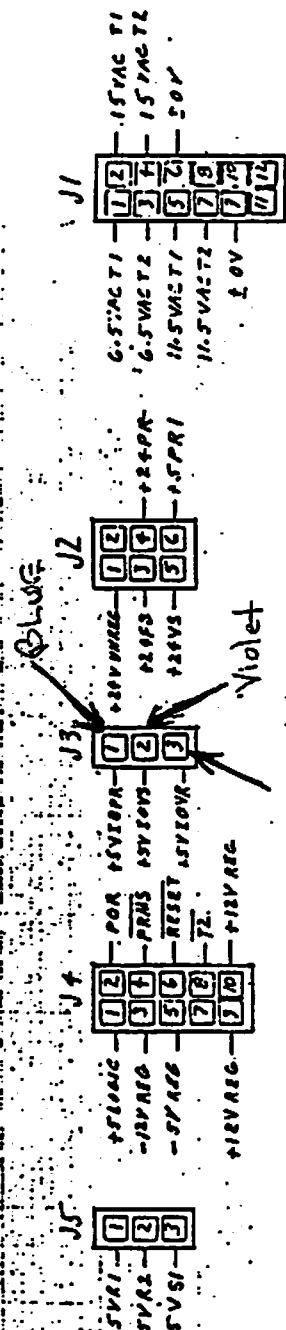

White/Brown traces

LOC. LOCATION	W.L. PART. NO.	TYPE
L2, 4, 6	376-0000	723
L3, 8	376-0240	LM339
L5	376-0074	LM741C
L7	376-0134	LM304
L10	376-0003	7474
	376-0020	7403

THE WHITE/BROWN TRACES AND BLUE WIRES ARE REVERSED

I.C. TYPE	LOCATION	PAIRS
LM339	L3	1
7403	L10	1
7474	L7	1

COMPONENT	W.L. PART. NO.	TYPE
R1, 13, 24, 43	380-3000	1/8W RESISTOR
R2	380-1001	5/8W DIODE
R3, 14, 16, 40, 53	380-2056	1W 250 OHM RESISTOR
R4, 5, 10	380-2129	1W 430 OHM RESISTOR
R5, 19	380-2111	1W 250 OHM RESISTOR
R7, 51, 60	380-2056	1W 250 OHM RESISTOR
R8	380-2129	1W 430 OHM RESISTOR
R9	380-2111	1W 250 OHM RESISTOR
R10, 11, 12, 23	380-2056	1W 250 OHM RESISTOR
R15, 17, 42, 50	380-2056	1W 250 OHM RESISTOR
R20, 41, 64, 66, 67, 68	380-2056	1W 250 OHM RESISTOR
R21, 34, 36, 37, 41	380-2129	1W 430 OHM RESISTOR
R22, 27, 29, 32, 65	380-2111	1W 250 OHM RESISTOR
R25	380-2056	1W 250 OHM RESISTOR
R26, 47	380-2129	1W 430 OHM RESISTOR
R27, 32, 51	380-2111	1W 250 OHM RESISTOR
R30	380-2056	1W 250 OHM RESISTOR
R31	380-2129	1W 430 OHM RESISTOR
R33	380-2111	1W 250 OHM RESISTOR
R35	380-2056	1W 250 OHM RESISTOR
R37	380-2129	1W 430 OHM RESISTOR
R44	380-2056	1W 250 OHM RESISTOR
R45, 48	380-2129	1W 430 OHM RESISTOR
R46, 42, 63	380-2111	1W 250 OHM RESISTOR
R54	380-2056	1W 250 OHM RESISTOR
R55	380-2129	1W 430 OHM RESISTOR
R56	380-2111	1W 250 OHM RESISTOR
R58, 59	380-2056	1W 250 OHM RESISTOR
R61	380-2129	1W 430 OHM RESISTOR
C5	375-1017	2W 2506A
C1, 2	375-1052	2W 6307
C3	375-1052	2W 6307
C4	375-1052	2W 6307
C6, 7, 8	375-1052	2W 6307
C9-12, 19-24, 27	375-1052	2W 6307
C14-17, 26	375-1052	2W 6307
C22	375-1052	2W 6307
C23	375-1052	2W 6307
C24	375-1052	2W 6307
C25	375-1052	2W 6307

CUSTOMER ENGINEERING
TECHNICAL ASSISTANCE CENTER
NEWSLETTER

#10113

IV.A.3

2200 SYSTEMS-MAINFRAMES-VP/MVP/LVP CPU'S.

TOPIC: LVP REGULATOR CARD (J-3 CONNECTOR)

5 volt connector clarification (J-3 on 210-7697, artwork R.1, R.2 and R.3). Some connectors were put on incorrectly.

Before applying power to a replacement regulator card (210-7697) check the mounting of the J-3 connector on the 7697 boards.

Looking at the component side, with the ground plane at the bottom and the adjustment pots on the right, J-3 is the vertically mounted three (3) pin connector closest to the diodes.

The following connections must be verified or modified (by mounting of the J-3 connector) for agreement with the following, viewed from the component side.

<u>REG. CARD</u>	<u>MATING CABLE (FROM HEAT SINK)</u>		
R-1 Artwork: correct way			
<u>Silk Screen</u>	<u>J-3 Connector Pins Viewed Inside Connector</u>	<u>Signal</u>	<u>Wire Color</u>
1	3	+5 V IO PR	Blue
2	2	+5 IO VS	Violet
3	1	+5 IO VR	White/Brown Tracer

R-2 and R-3 Artwork: correct way

<u>Silk Screen</u>	<u>J-3 Connector Pins Viewed Inside Connector</u>	<u>Signal</u>	<u>Wire Color</u>
1	1	+5 V IO PR	Blue
2	2	+5 V IO VS	Violet
3	3	+5 IO VR	White/Brown Tracer

If you are updating by replacement of a regulator card, check before applying power, and remount the J-3 connector on the regulator card if required. Otherwise, system damage may occur. It is recommended that spares should be checked.

CUSTOMER ENGINEERING
TECHNICAL ASSISTANCE CENTER
NEWSLETTER

#10120

IV.A.3

2200 SYSTEMS-MAINFRAMES-VF/VVP/LVP CPU'S.

TOPIC: LVP DEFECTIVE PARTS

Return all defective LVP parts through normal channels
(supersedes TAC Newsletter #00930, Topic: LVP Reminders,
Item 3. also supersedes TAC Newsletter #01209, Topic: Return of
Defective Winchester Drives, Item 1.)

CUSTOMER ENGINEERING
TECHNICAL ASSISTANCE CENTER
NEWSLETTER

#10120

IV.A.3

.2200 SYSTEMS-MAINFRAMES-UP/HVP/LVP CPU'S.

TOPIC: LVP DC CABLES: CAUTIONARY

Exercise care when removing or replacing the DC test plug/cable on the motherboard. This six (6) conductor cable could be confused with the drive(s) DC cable inadvertently.

CUSTOMER ENGINEERING
TECHNICAL ASSISTANCE CENTER
NEWSLETTER

#10127

IV.A.3

2200 SYSTEMS-MAINFRAMES-VP/MVP/LVP CPU'S.

TOPIC: LVP DPU SECTION UPGRADES

Technical Information

The E-REV levels of the updated boards have been set back to "1" via ECO's as of 11/18/80.

The updated boards can be recognized by the following distinguishing features (plus a "1" on the backside, circuit side of the board).

ECO

16884	210-7694:	L5 contains an IC socket L8 is a 74S74 L9 is a 74LS04 Potentiometers are glyptalled
16885	210-7695:	L37 contains a 74S32
16886	210-7696:	PROM's are R5 L8 is a 74LS04 L19 is a 74LS04

With these latest ECN's incorporated:

- Switch 3 of switchbank SW1 on the WL# 210-7696-A (-B) board must be set OFF.
- The total available sectors on the DSDD Diskette Drive is 3874 (sector 0-3873) plus one track (the first track on side 0) of single-density. The available sectors provide storage for 998,400 bytes of data. These figures reflect the change in tracks/surface from 77 to 75.
- Formatting time for the Winchester Disk Drive is approximately 13 minutes.
- Formatting for the DSDD Diskette Drive is approximately 2 minutes.
- The PLO adjustment is no longer required. The potentiometers will be glyptalled after the initial adjustment has been performed in Manufacturing.
- Initially, when first powered-up and/or reset is keyed, it is normal to have the Winchester drive do several TRK 00 seeks. After several minutes of operation, resets should not cause TRK 00 seeks.

CUSTOMER ENGINEERING
TECHNICAL ASSISTANCE CENTER
NEWSLETTER

#10127

IV.A.3

2200 SYSTEMS-MAINFRAMES-VP/MVP/LVP CPU'S.

TOPIC: LVP SYSTEM CHANGES

LVP systems and spares shipped after 11/18/80 have several new parameters (i.e. PLO adjustments need NOT be done in the field, sector addresses for the floppy are 0-3873).

For more information refer to Category IV.A.3, TAC Newsletters(s) #01125, Item (10) TOPIC: 2200 LVP/SVP Winchester Disk/DSDD Disk Processing Unit; plus, #01216, Item (3) TOPIC: 210-7696A and B.

CUSTOMER ENGINEERING
TECHNICAL ASSISTANCE CENTER
NEWSLETTER

#10127

III.A.12

PERIPHERALS-DISK DRIVES-SHUGART SA-1000 8" WINCHESTER

TOPIC: DRIVE MOUNTING HARDWARE

When replacing a Winchester drive, before you put the defective drive in a shipping container, check to see if the replacement drive has the required hardware.

There is a possibility that some drives were shipped without:

<u>ITEM</u>	<u>WLI P/N</u>
Shoulder Washer	653-0052
Belleville Spring Washer	653-0039
Phillips Screw	650-3200

So, if necessary, remove these parts from the defective drive and install them on the replacement drive.

If these parts are not installed, there will be no mounting on the front of the drive to the LVP frame.

CUSTOMER ENGINEERING
TECHNICAL ASSISTANCE CENTER
NEWSLETTER

#10217

IV.A.3

2200 SYSTEMS-MAINFRAMES-VP/MVP/LVP CPU'S.

TOPIC: POSSIBLE COMPATIBILITY PROBLEMS (210-7696-A/B)

Component Engineering has identified a possible problem area on the LVP uP and memory board (210-7696(A/B)).

There is a possibility that some 210-7696(A/B) boards may not be compatible with all DPU board sets.

The troublesome components are located at positions L34 and L35 on the board. They can be identified as being National Semi-Conductor LS257 IC's with the symbol of a star on the package.

We believe all the boards were identified and purged, but there is a possibility that a few of these boards may be in the field. In that case, IC's have to be replaced with another manufacturer's other than National Semi-Conductor's at the two above-mentioned locations.

CUSTOMER ENGINEERING
TECHNICAL ASSISTANCE CENTER
NEWSLETTER

#10217

IV.A.3

2200 SYSTEMS-MAINFRAMES-VP/MVP/LVP CPU'S.

TOPIC: 2200-LVP

Please be advised - Engineering has decided to incorporate the existing ECO's into the new artwork for the DPU boards. The new boards will be compatible with the existing boards. The new boards will be functionally equivalent to the old boards but, more aesthetically pleasing.

Present Boards		New Boards
210-7694	Interface	210-8694
210-7695-A	Disk Controller	210-8695-A
210-7696-A(A/B)	uP and Memory	210-8696-(A/B)

Category yet to be determined

2200 SVP

The 2200 SVP system is being released from Manufacturing. There is no training scheduled. The SVP will be supported by LVP experienced personnel. Preliminary documentation has been sent to ATOMS and ATS personnel. Final documentation should be available on or about February 23.



LABORATORIES, INC.

CUSTOMER ENGINEERING
TECHNICAL ASSISTANCE CENTER
NEWSLETTER

#10303

III.A.12

PERIPHERALS-DISK DRIVES-SHUGART SA-1000 8" WINCHESTER

TOPIC: WINCHESTER DRIVES USED ON LVE/SVE

R & D has determined that the head activator clip (452-2683-XB) used on the Winchester drive is no longer required during shipment. Winchester Drive P/N's - 278-4013, 278-4013-1, 278-4014 & 278-4014-1.

The heads should be positioned at the innermost sector.

	2MB_Drive	4MB_Drive	8MB_Drive
Innermost Sectors	8127	16319	32639

If it is possible to access the drive through the use of keyboard commands, use immediate mode statement:

VERIFY F (XXXXX, XXXXX) - EXECUTE. Where XXXXX = innermost sector.

If not responsive to keyboard commands, with power on let drive run for 2.0 minutes then manually rotate damper assembly clock-wise to position the track 00 flag at approximately 2 o'clock (track 00 detector as a reference is at 6 o'clock) - then power down.

Prior to removal from a system, the heads should be positioned at the innermost sector, the system powered down and the spindle lock attached (451-7054 and 650-3140) before being placed in the padded shipping container.

CUSTOMER ENGINEERING
TECHNICAL ASSISTANCE CENTER
NEWSLETTER

#10519

IV.A.3

2200 SYSTEMS-MAINFRAMES-VP/MVP/LVP CPU'S.

TOPIC: LVP DPU

There has been four "LED's" added to the 8696A version DPU card. These LED's are error displays for the internal DPU diagnostics.

The following is the description of these diagnostics and LED's:

1.0 TITLE

Power-up for the LVP or SVP Fixed/Floppy Disk Processing Unit (DPU).

2.0 REVISION/DATE

```

:-----:
:   Date:  November 6, 1980   :
: Documentation Release:  Rev. 1.3 :
: Software Release:         :
: Part Number:   378-4223R5, 4 or 8 meg Ver. :
:                   378-4230R5, 2 or 8 meg Ver. :
:-----:

```

3.0 REFERENCE DOCUMENTS

Hardware design specifications for LVP - SVP DPU

4.0 CONFIGURATION REQUIREMENTS

4.1 Hardware

The DPU Cards must be board numbers 8694, 8695 and 8696. If the original boards (7694, 7695 & 7696) are used, they must meet the following conditions:

210-7694 must have all ECO's up to and including 16884.*

210-7695 must have all ECO's up to and including 16885.*

210-7696 must have all ECO's up to and including 16886.*

CUSTOMER ENGINEERING
TECHNICAL ASSISTANCE CENTER
NEWSLETTER

#10519

IV.A.3

2200 SYSTEMS-MAINFRAMES-VP/MVP/LVP CPU'S.

TOPIC: LVP DPU (continued)

If the 7696, 7695 and 7694 boards are R0 or R1 they should be scrapped. Use only R2 boards in the 76 series.

4.2 Software

Three PROMs for 210-7695:

L1 = 378 - 4224 R00*
L2 = 378 - 4225 R00*
L3 = 378 - 2560 R01*

Four Firmware PROMs for 7696 Board:

L29 = 378 - 4220 R5*
L28 = 378 - 4221 R5*
L27 = 378 - 4222 R5*
L26 = 378 - 4223 R5 (4 or 8 meg Version and Diagnostic)*
L26 = 378 - 4230 R5 (2 or 8 meg Version and Diagnostic)*

*Note: These are considered minimum revision levels.

5.0 PROGRAM DESCRIPTION

This program is designed to check the DPU hardware during power-up to verify as much hardware as possible without reading, writing or formatting the disk media.

6.0 LOAD PROCEDURE

Place the four LVP/SVP DPU firmware PROMs into the 7696 board:

L29 = 378-4220R5,
L28 = 378-4221R5,
L27 = 378-4222R5,
L26 = 378-4223R5 or 378-4230R5.

CUSTOMER ENGINEERING
TECHNICAL ASSISTANCE CENTER
NEWSLETTER

#10519

IV.A.3

2200 SYSTEMS-MAINFRAMES-VP/MVP/LVP CPU'S.

TOPIC: LVP DPU (continued)

7.0 OPERATING INSTRUCTIONS

This diagnostic will automatically start from power on. If the program detects any errors, the SA850 LED will, unconditionally blink at a slow rate. The error code for the failing test will be displayed on the error LEDs on the 8696 board. The 7696 board has no error LED's. If the LEDs are not available, the ZEBUG may be used to see the error codes. To observe the error codes, after the SA850 LED starts blinking, depress the "DELETE" key on the ZEBUS. The error code will be in the "c" register. The bad bit will be in the "h" register if the Simplified Moving Inversions Test fails.

8.0 REVISION HISTORY

- 1.1 Changed error codes and error reporting. Deleted Protocol Test.
- 1.2 Explains error LEDs and new switch setting.
- 1.3 Corrected LED explanations and hardware.

9.0 MISCELLANEOUS

None

CUSTOMER ENGINEERING
 TECHNICAL ASSISTANCE CENTER
 NEWSLETTER

#10519

IV.A.3

2200 SYSTEMS-MAINFRAMES-VP/MVP/LVP CPU'S.

TOPIC: LVP DPU (continued)

1.0 Tests in this Program

Test Number (LED Code)

Bit No.	LED			
	3 ^{Top}	2	1	0 ^{Bottom}
1. Z80 CPU Tests	(0)	(0)	(0)	(1)
2. PROM Checksum Test	(0)	(0)	(1)	(0)
3. 2200 Status Register Test	(0)	(0)	(1)	(1)
4. Basic Parity Function Test	(0)	(1)	(0)	(0)
5. Parity Circuit Exerciser Test	(0)	(1)	(0)	(1)
6. DMA Tests	(0)	(1)	(1)	(0)
7. CTC Tests	(0)	(1)	(1)	(1)
8. Static Disk Status Register Test	(1)	(0)	(0)	(0)
9. 7695 Tests	(1)	(0)	(0)	(1)
10. Read/Write Frequency Clock Test	(1)	(0)	(1)	(0)
11. SA850 Tests	(1)	(0)	(1)	(1)
12. SA1000 Tests	(1)	(1)	(0)	(0)
13. Simplified Moving Inversions	(1)	(1)	(0)	(1)

NOTE: The SA1000 Test will wait 25 seconds for drive READY before an error indication is given. Striking RESET on the keyboard before the power up tests have passed or failed will cause the test to restart from the beginning.

2.0 Error Codes

The error codes will be stored in the "c" register of the Z80. A provision has been made in the program to output the error code to an LED display. The 8696 board will have four LED's in the upper left hand corner on the component side of the board. The codes sent to the LED's are exactly as shown in section 1.0 of appendix A. Viewing the 8696 card from its component side, but 0 is the left most LED (with edge connector down). An error code of all LED's "on" (1111) indicates a hard CPU failure.

Appendix B contains further information on the tests and meaning of error codes.

CUSTOMER ENGINEERING
TECHNICAL ASSISTANCE CENTER
NEWSLETTER

#10519

IV.A.3

2200 SYSTEMS-MAINFRAMES-VP/MVP/LVP CPU'S.

TOPIC: LVP DPU (continued)

7695 TESTS

- SUBTEST 1. THIS TEST CHECKS THE STATIC STATE OF THE CONTROLLER STATUS REGISTER WITHOUT THE BYTE COUNTERS INCREMENTING.
- SUBTEST 2. THIS TEST CHECKS THE FIFO AND SOME FIFO CONTROL LOGIC. THE TEST USES DMA TRANSFERS TO WRITE/READ/VERIFY DIFFERENT PATTERNS IN AND OUT OF THE FIFO.
- SUBTEST 3. THIS TEST CHECKS THE FORMAT ENABLE FLOP AND DISK DEVICE REQUEST. THE DISK DEVICE REQUEST IS USED FOR DISK DMA TRANSFERS.
- SUBTEST 4. THIS TEST CHECKS THE CONTROLLER ERROR FLAGS.
- SUBTEST 5. THIS TEST CHECKS FOR TRANSITIONS IN THE CONTROLLER STATUS REGISTER. THE BITS CHECKED ARE FROM THE LOW ORDER BYTE COUNTER AND THE DATA TRANSFER COMPLETE SIGNAL.
- SUBTEST 6. THIS TEST CHECKS THE DISK DONE INTERRUPT.

NOTE: THE SUBTESTS 3 - 6 ARE RUN FIRST WITH THE FIXED, THEN DOUBLE DENSITY AND FINALLY THE SINGLE DENSITY PROMS SELECTED.

ERROR CODE SENT TO THE 4 L.E.D.'S = BINARY "1001"

PROBABLE ORDER OF FAILURE : BOARD OR FAULT

1. 7695 OR PROMS ON 7695
2. 7696
3. 7695

CUSTOMER ENGINEERING
TECHNICAL ASSISTANCE CENTER
NEWSLETTER

#10519

IV.A.3

2200 SYSTEMS-MAINFRAMES-VP/MVP/LVP CPU'S.

TOPIC: LVP DPU (continued)

SA850 TEST

THIS TEST CHECKS THE FLOPPY DRIVE IF ONE IS ON THE SYSTEM AS INDICATED BY THE SWITCHES ON THE 7696 BOARD. THE TEST LOOKS FOR TRACK ZERO FROM THE FLOPPY DRIVE. IF THE DRIVE IS NOT AT TRACK ZERO, THE TEST WILL TRY TO RESTORE THE DISK. AFTER FINDING TRACK ZERO THE HEAD IS STEPPED IN ONE TRACK. TRACK ZERO IS CHECKED NOW TO BE OFF. IF TRACK ZERO IS OFF, THE TEST STEPS THE HEAD BACK ONE TRACK AND CHECKS AGAIN FOR TRACK ZERO.

ERROR CODE SENT TO THE 4 L.E.D.'S = BINARY "1011"

PROBABLE ORDER OF FAILURE : BOARD OR FAULT

1. 7694, SA850, SWITCHES OR CABLES.
2. 7696
3. 7695

CUSTOMER ENGINEERING
TECHNICAL ASSISTANCE CENTER
NEWSLETTER

#10519

IV.A.3

2200 SYSTEMS-MAINFRAMES-VP/MVP/LVP CPU'S.

TOPIC: LVP DPU (continued)

READ/WRITE FREQUENCY CLOCK TEST

THIS TEST CHECKS TO SEE IF THE BYTE COUNTER RUNS AT SINGLE DENSITY, DOUBLE DENSITY AND FIXED FREQUENCIES. THE FIXED FREQUENCY IS APPROXIMATELY 8.68 TIMES THE DD-FLOPPY FREQUENCY. THE TEST CHECKS THAT THE FIXED FREQUENCY IS GREATER THAN 8 TIMES THE DD-FLOPPY FREQUENCY. THE TEST ALSO CHECKS THAT THE SINGLE DENSITY FREQUENCY IS LESS THAN THE DOUBLE DENSITY FREQUENCY.

ERROR CODE SENT TO THE 4 L.E.D.'S = BINARY "1010"

PROBABLE ORDER OF FAILURE : BOARD OR FAULT

1. 7694 OR 7695
2. 7696

SA1000 TEST

THIS TEST CHECKS THE FIXED DRIVE IF ONE IS ON THE SYSTEM AS INDICATED BY THE SWITCHES ON THE 7696 BOARD. THE TEST LOOKS FOR DRIVE READY, INDEX PULSES AND TRACK ZERO. IF THE DRIVE IS NOT AT TRACK ZERO, THE TEST WILL TRY TO RESTORE THE DISK. AFTER FINDING TRACK ZERO THE HEAD IS STEPPED IN ONE TRACK. TRACK ZERO IS CHECKED NOW TO BE OFF. IF TRACK ZERO IS OFF, THE TEST STEPS THE HEAD BACK ONE TRACK AND CHECKS AGAIN FOR TRACK ZERO.

ERROR CODE SENT TO THE 4 L.E.D.'S = BINARY "1100"

PROBABLE ORDER OF FAILURE : BOARD OR FAULT

1. 7694, SA1000, SWITCHES OR CABLES
2. 7696
3. 7695

CUSTOMER ENGINEERING
TECHNICAL ASSISTANCE CENTER
NEWSLETTER

#10519

IV.A.3

2200 SYSTEMS-MAINFRAMES-VP/MVP/LVP CPU'S.

TOPIC: LVP DPU (continued)

CTC TESTS

- SUBTEST 1. TEST THE BASIC FUNCTIONS OF THE CHIP (CHANNEL 0-3). TEST THE DOWN COUNTER FOR EACH CHANNEL.
- SUBTEST 2. THIS TEST CHECKS THE ABILITY OF EACH CHANNEL TO EXECUTE INTERRUPTS WHILE IN TIMER MODE.

ERROR CODE SENT TO THE 4 L.E.D.'S = BINARY "0111"

PROBABLE ORDER OF BOARD FAILURE : BOARD OR FAULT

1. 7696 OR L37 (CTC CHIP)
2. 7694
3. 7695

STATIC DISK STATUS REGISTER TEST

THIS TEST CHECKS THE STATIC STATE OF THE DISK STATUS REGISTER WITHOUT ANY DISK DRIVES SELECTED.

ERROR CODE SEND TO THE 4 L.E.D.'S = BINARY "1000"

PROBABLE ORDER OF FAILURE : BOARD OR FAULT

1. 7694
2. 7696
3. CABLES OR DRIVE PROBLEMS
4. 7695

CUSTOMER ENGINEERING
TECHNICAL ASSISTANCE CENTER
NEWSLETTER

#10519

IV.A.3

2200 SYSTEMS-MAINFRAMES-VP/MVP/LVP CPU'S.

TOPIC: LVP DPU (continued)

PARITY CIRCUIT EXERCISER TEST

THIS TEST IS DESIGNED TO EXERCISE THE PARITY GENERATOR CIRCUIT.

ERROR CODE SENT TO L.E.D.'S = BINARY "0101"

PROBABLE ORDER OF BOARD FAILURE : BOARD

1. 7696
2. 7695 OR 7694

DMA TESTS

- SUBTEST 1. TEST THE BASIC POWER UP CONDITIONS OF THE CHIP AND BASIC FUNCTIONALITY OF THE DMA CHIP.
- SUBTEST 2. TEST FOR CHANNEL SELECT PROBLEMS.
- SUBTEST 3. TEST CHANNEL 0-3 CURRENT ADDRESS REGISTERS (CA) AND WORD COUNT REGISTERS (WC).
- SUBTEST 4. TEST THE DMA FOR BLOCK MOVES. THE TEST DOES AN 8K TO 8K MEMORY TRANSFER.

ERROR CODE SENT TO THE 4 L.E.D.'S = BINARY "0110"

PROBABLE ORDER OF BOARD FAILURE: BOARD OR FAULT

1. 7696 OR L25 (DMA CHIP)
2. 7694
3. 7695

CUSTOMER ENGINEERING
TECHNICAL ASSISTANCE CENTER
NEWSLETTER

#10519

IV.A.3

2200 SYSTEMS-MAINFRAMES-VP/MVP/LVP CPU'S.

TOPIC: LVP DPU (continued)

BASIC PARITY FUNCTION TEST

THIS TEST CHECKS THE CONTROLLERS ABILITY TO FORCE BAD PARITY.
FORCING BAD PARITY CHECKS THE PARITY GENERATOR, THE PARITY STATUS BIT
AND NON-MASKABLE INTERRUPTS.

ERROR CODE SENT TO THE 4 L.E.D.'S = BINARY "0100"

PROBABLE ORDER OF BOARD FAILURE : BOARD

1. 7696 OR 7694
2. 7695

SIMPLIFIED MOVING INVERSIONS TEST

THIS TEST IS A FAST YET VERY EFFECTIVE RAM VERIFICATION TEST.
THE TEST USES MOVING INVERSIONS RAM ACCESS PROCEDURE WITH A
SEMI-COMPLEMENT ADDRESSING SCHEME INSTEAD OF A ROTATING
INCREMENTING/DECREMENTING ADDRESSING SCHEME.

ERROR CODE SENT TO L.E.D.'S WILL NOT BE A CONSTANT CODE BUT
AS SHOWN BELOW:

1. L.E.D.'S = BINARY "1101"
2. DELAY
3. L.E.D.'S = BINARY REPRESENTATION OF BAD RAM
4. DELAY AND REPEAT

L46 = BINARY "0000"

L45 = BINARY "0001"

L44 = BINARY "0010"

L43 = BINARY "0011"

L42 = BINARY "0100"

L41 = BINARY "0101"

L40 = BINARY "0110"

L39 = BINARY "0111"

L38 = BINARY "1000"

PROBABLE ORDER OF FAILURE : BOARD OR FAULT

1. 7696 OR RAM(S) ON 7696
2. 7695 OR 7694

CUSTOMER ENGINEERING
TECHNICAL ASSISTANCE CENTER
NEWSLETTER

#10519

IV.A.3

2200 SYSTEMS-MAINFRAMES-VP/MVP/LVP CPU'S.

TOPIC: LVP DPU (continued)

Z80 CPU TEST

THIS TEST IS A GENERAL Z80 TEST. THE TEST CHECKS THE CONDITION CODE FLAGS, INTERNAL REGISTERS AND VARIOUS INSTRUCTIONS USED TO CHECK THE FLAGS AND REGISTERS. MOST CPU FAILURES PROBABLY WILL RESULT IN UNPREDICTABLE ERRORS.

ERROR CODE SENT TO THE 4 L.E.D.'S = BINARY "0001"

PROBABLE ORDER OF BOARD FAILURE : BOARD
1. 7696
2. 7695 OR 7694

PROM CHECK SUM TEST

THIS TEST PERFORMS A CHECK SUM ON THE 6K OF FIRMWARE PROM AND 2K OF DIAGNOSTIC PROM.

ERROR CODE SENT TO THE 4 L.E.D.'S = BINARY "0010"

PROBABLE ORDER OF BOARD FAILURE : BOARD
1. 7696 OR PROMS
2. 7695 OR 7694

2200 STATUS REGISTER TEST

THIS TEST CHECKS THE READ/WRITE BITS IN THE 2200 STATUS REGISTER.

ERROR CODE SENT TO THE 4 L.E.D.'S = BINARY "0011"

PROBABLE ORDER OF BOARD FAILURE : BOARD OR FAULT
1. 7696 OR 7694
2. 7695

CUSTOMER ENGINEERING
TECHNICAL ASSISTANCE CENTER
NEWSLETTER

#10519

IV.A.3

2200 SYSTEMS-MAINFRAMES-VP/MVP/LVP CPU'S.

TOPIC: LVP DPU (continued)

3.0 Switch Bank Settings

Switches #1 and #3 will be used to select the tests executed by the power-up program. If the hardware changes such that the visibility into the DPU increases or existing tests need to be changed, a new version of the power-up program will be released. Having the levels of tests run switch selectable, the Field Engineer can use an older ECN level board in with new boards just by changing the switch setting back to the revision of the older board. At the present time, the switch bank on the 7696 board must be set with switch #1 set to the "on" position. If the 7695 board has ECN #16545D implemented, set switch #3 to the "off" position. Otherwise, set switch #3 to the "on" position. Switch 1 and 3 "on" will be the setting for the oldest revision boards. Switch 1 "on" and 3 "off" will be the setting for properly updated 7695 boards. The new card set (8696, 8695, 8694) will have switch 1 "ON" and 3 "OFF" on the 8696 board.

NOTE: The Read/Write Frequency Test and Subtests 3 - 6 in the 7695 Tests, run only when switch #3 is "off".

CUSTOMER ENGINEERING
TECHNICAL ASSISTANCE CENTER
NEWSLETTER

#10721

III.A.0

PERIPHERALS-DISK DRIVES-GENERAL TECHNICAL (DISKS).

IDPIC: WINCHESTER MOTOR SHIPPING CLAMPS

The head clamp has been determined to have little impact in preventing damage to the Winchester drive during shipment and has been discontinued from use. No change has been made to the spindle clamp. Should a Winchester drive be received with the spindle clamp missing or not installed properly, notify Quality Assurance via normal feedback procedures.

CUSTOMER ENGINEERING
TECHNICAL ASSISTANCE CENTER
NEWSLETTER

#10929

III.A.14

PERIPHERALS-DISK DRIVES-SHUGART Q2000 WINCHESTER (8 INCH).

TOPIC: QUANTUM 8 INCH MEDIA FIXED DISK DRIVE

WANG LABORATORIES WILL SOON MAKE AVAILABLE, IN SEVERAL SYSTEM MODELS, THE QUANTUM 8 INCH MEDIA FIXED DISK DRIVE.

THE QUANTUM SERIES 2000 DISK DRIVE IS A RANDOM ACCESS STORAGE DEVICE WITH ONE, TWO, THREE, OR FOUR NON-REMOVABLE 8 INCH RIGID DISKS AS STORAGE MEDIA. EACH DISK SURFACE EMPLOYS ONE MOVABLE HEAD TO ACCESS THE 512 DATA TRACKS. THE FOUR MODELS OF THE Q2000 SERIES ARE Q2010, Q2020, Q2030, AND Q2040.

	<u>PLATTERS</u>	<u>MOVEABLE HEADS</u>	<u>STORAGE</u>
Q2010	1	10.66 MEGABYTE	2
Q2020	2	21.33 "	4
Q2030	3	32.00 "	6
Q2040	4	42.66 "	8

THE Q2000 SERIES DISK DRIVE IS SUPPLIED WITH AN ACTUATOR LOCK AND A SPINDLE LOCK FOR SHIPPING PROTECTION. THESE LOCKS MUST BE REMOVED BEFORE THE SYSTEM IS POWERED UP. FOLLOW THE STEPS BELOW FOR REMOVING THE LOCKS. PLEASE NOTE THAT IN SYSTEMS SHIPPED WITH THIS MODEL DRIVE, THE DRIVE MUST BE REMOVED FROM THE SYSTEM TO PERFORM THESE STEPS.

MOTOR LOCKING CLIP:

- A) STAND DRIVE ON EDGE TO UNLOCK DRIVE MOTOR.
- B) LOOSEN 11/32 INCH HEX NUT.
- C) ROTATE LOCKING CLIP AWAY FROM PULLEY. DO NOT ROTATE PULLEY.
- D) RETIGHTEN 11/32 INCH HEX NUT.

ACTUATOR LOCK:

UNLOCK ACTUATOR BY ROTATING THE ACTUATOR LOCK CCW AS FAR AS IT WILL GO (APPROX. 1/2 TURN). DO NOT FORCE. THE ACTUATOR LOCK IS LOCATED ON THE BOTTOM OF THE DRIVE.

CUSTOMER ENGINEERING
TECHNICAL ASSISTANCE CENTER
NEWSLETTER

#20316

III.A.14

QUANTUM Q-2000 SERIES (8" WINCHESTER) DRIVES

TOPIC: GENERAL INFORMATION ON THE QUANTUM

The Quantum requires approximately 30 minutes to format one platter. The 32 Meg Quantum (Q-2040) has two platters, so to format both platters, it will require at least one hour.

The platters in the 32 Meg Quantum should be accessed in the same way as the platters are for the 2280 Phoenix. Select either D11 or D12 to access the individual platter. If the drive address (310, 320, etc.) is used for the 32 Meg Quantum, only one platter will be accessed, thus limiting you to 16 Meg of storage.

The Quantum drives that are being sent out ARE NOT FORMATTED and must be formatted before they can be used. Some drives may have 20 to 30 tracks formatted, but the drive must be re-formatted before the system can be released for customer use. Also note if the drive is a 32 Meg, both platters must be formatted.

TOPIC: 210-8696 SWITCH SETTINGS

The LVP-C uses the Quantum Winchester. The switch settings for the 210-8696 FCA are:

Switch Settings	#2	#4	#8	
	1	1	1	No Fixed Drive
	1	0	1	Small Fixed-
				210-8696-B = 2-Meg Shugart
				210-8696-A = 4-Meg Shugart
	0	1	1	8-Meg Fixed Shugart
	1	1	0	16-Meg Fixed Quantum
	0	1	0	32-Meg Fixed Quantum

Switch Number #6

1 = No Floppy installed
0 = Floppy installed

Switch Number #3 = OFF

All other switches should be in the 'ON' position.
(1 = ON & 0 = OFF)

CUSTOMER ENGINEERING
TECHNICAL ASSISTANCE CENTER
NEWSLETTER

#20316

IV.A.3

2200 SYSTEMS-MAINFRAMES-VP/MVP/LVP CPU'S.

TOPIC: NEW DPU PROMS FOR THE 210-8696 PCA

The 210-8696 Microcomputer/Memory (DPU) PCA has had its PROMs upgraded to Revision R-8. The PROM loading is as shown below.

** Do NOT use R6 or R7 PROMS,*

Location	Old PROM Number	New PROM Number
L-29	378-4220-R*	378-4220-R8
L-28	378-4221-R*	378-4221-R8
L-27	378-4222-R*	378-4222-R8
L-26**	378-4223-R*	378-4223-R8
L-26**	378-4230-R*	378-4230-R8

* - This includes PROMs that are revision R-5, R-6, R-7, plus any revision older than R-5.

** - L-26 will be a 378-4223 on the 210-8696-A for either the 4 or 8 Meg Winchester.

L-26 will be a 378-4230 on the 210-8696-B for either the 2 or 8 Meg Winchester.

The PROM revision R-7, and above, requires a new PLL diagnostic diskette. The P/N of the new diskette is 732-0009A (reference the other entries in section IV.A.3 for TAC Newsletter #20316)

IV.A.3

2200 SYSTEMS-MAINFRAMES-VP/MVP/LVP CPU'S.

TOPIC: NEW "LEG LEVELERS" FOR THE 2200 LVP

The 2200-LVP's are being shipped with new, larger, casters which enable the LVP system to roll easily. With the new casters, the present screw down legs will not reach the floor when the customer tries to level the system in a permanent location. The new, longer levelers which should be used with the larger casters, may be ordered by WLI P/N 655-0284.

IV.A.3

2200 SYSTEMS-MAINFRAMES-VP/MVP/LVP CPU'S.

TOPIC: NEW PLL UTILITY DISKETTE - P/N 732-0009A

Please be aware that with the DPU PROMs being upgraded to R-8, the present PLL Utility Diskette, P/N 732-0009, will not operate when trying to do the PLL alignment on the Winchester. If your system has the R-7 or R-8 revision PROMs on the 210-8696 PCA, you must order the new PLL utility diskette. The WLI P/N for the new diskette is 732-0009A.

Please refer to the other entries in section IV.A.3 for TAC Newsletter #20316, for the PROM loading for the 210-8696 DPU PCA

CUSTOMER ENGINEERING
TECHNICAL ASSISTANCE CENTER
NEWSLETTER

#20518

IV.A.3

2200 SYSTEMS-MAINFRAMES-VP/MVP/LVP CPU'S.

TOPIC: LVP & SVP WILL NOT COME UP ON THE FIRST POWER-ON

There have been several reports of LVP's not coming up "ready" when they are first powered on. The problem is in the new Shugart Winchester Drives, (it has only one control board). R & D is working on the problem and will inform us of the fix.

Until the problem is fixed, the only solution is to power on the system a second time (this will give the disk additional time to pass power-up diagnostics).

Do not replace the Shugart Winchester Disk for this problem.

CUSTOMER ENGINEERING
TECHNICAL ASSISTANCE CENTER
NEWSLETTER

#21109

IV.B.1

2200 SYSTEMS-INTERFACE-I/O CONTROLLERS.

TOPIC: 22032 TRIPLE CONTROLLER - REAL TIME CLOCK

To run a real time clock on the triple controller, you must have

210-7816A daughter board.
with R1 proms.
Minimum E-REV 2.
MVP 2.4 software.

CUSTOMER ENGINEERING
TECHNICAL ASSISTANCE CENTER
NEWSLETTER

-#30215

IV.A.3 (4103)

2200 SYSTEMS-MAINFRAMES-VP/MVP/LVP/SVP CPU'S.

TOPIC: PARITY ERRORS ON 'C' CHASSIS

A problem has been found on the LVP-C and MVP-C where the customer will get intermittent parity errors (PEDM).

The solution to this problem is a new PCA, 210-6791-1 STACK PCA.

All 'C' chassis, both MVP and LVP in the field, should be updated to incorporate the new PCA.

CUSTOMER ENGINEERING
TECHNICAL ASSISTANCE CENTER
NEWSLETTER

#30426

4103 (IV.A.3)

2200 SYSTEMS-MAINFRAMES-VP/MVP/LVP/SVP CPU'S.

TOPIC: GENERAL INFORMATION ON THE LVP/SVP DPU

The following information is being supplied in an attempt to keep the field updated on the latest microcode, and problem areas in the LVP/SVP DPU.

- 1) When doing the PLL adjustment on the 210-8696 PCA, you MUST have at least 1.5 turns on each pot (floppy & fixed) from error to error. This applies when doing the PLL to both the floppy and the fixed disk drives. If you cannot get 1.5 turns on both pots, the board should be returned as defective. Running the system with a PCA from which you cannot get 1.5 turns on both pots will result in intermittent I-93 errors.
- 2) The 2200 SVP/LVP DPU Microcode has been updated to revision R-9. When updating to R-9 Microcode, ORDER THE FCO KIT AND NOT THE INDIVIDUAL PROM'S.

The reason for change is:

- A. An I-93 error would occur when copying across an alternate sector on a Shugart Winchester Disk.
- B. The Data Processing Unit (DPU) would not pass power-up diagnostics when its switches were set to floppy only.
- C. The floppy door will unlock after 5 seconds of non-use.
- D. A format error found within the alternate sector during a FORMAT DISK operation is now recovered by the software.

The description of the changes are:

210-8696-A	FCO kit # 728-0013-A
IC #	Location
378-4220-R9	L-29
378-4221-R9	L-28
378-4222-R9	L-27
* 378-4223-R9	L-26

210-8696-B	FCO kit # 728-0015-A
IC #	Location
378-4220-R9	L-29
378-4221-R9	L-28
378-4222-R9	L-27
* 378-4230-R9	L-26

- * Please note that the PROM 378-4230-R9 is used only with the 2 Meg Winchester Drive. The PROM 378-4223-R9 is used with all other Winchester Drives.

CUSTOMER ENGINEERING
TECHNICAL ASSISTANCE CENTER
NEWSLETTER

#30426

4103 (IV.A.3)

2200 SYSTEMS-MAINFRAMES-VP/MVP/LVP/SVP CPU'S...

TOPIC: GENERAL INFORMATION ON THE LVP/SVP DPU (CONTINUED)

- 3) It has been reported that the 210-8696 DPU PCA has been shipped with the CPU chip at location L-30 being a Z80 chip and not a Z80-A. If you have an 2236 MXE controller which fails under heavy loads, check to insure the CPU chip is correct. If it is not a Z80-A, return the PCA as a defective board noting on the repair tag the problem.
- 4) The field has uncovered a problem using IBM formatted diskettes on an LVP. It seems a specific IBM disk format produces I-93 errors on the LVP and has only been seen using the 3741 option. The problem has been traced to a change in the way IBM formats each sector header.

To alleviate this problem, the customer should be certain he/she uses Wang "green label" diskettes. These diskettes have sector formats already on them. If reformatting is required, it must be done on the LVP. Any disk formatted on the 3741 system may cause I-93 errors on the LVP.

If problems arise where the customer is unable to live within these guidelines, please contact the area office with the customer's name, phone number, address and customer contact name. The Area will have the information forwarded to Corporate Customer relations for their direct dealing with the customer.

CUSTOMER ENGINEERING
TECHNICAL ASSISTANCE CENTER
NEWSLETTER

#30809

4103

2200 SYSTEMS-MAINFRAMES-VF/MVP/LVP SVP

TOPIC: POSSIBLE CAUSE OF "BACKUP" OR "VERIFY" ERRORS.

If while running "BACKUP" or "VERIFY" excessive errors are encountered, the 24VDC Power Supply should be checked for AC ripple. To perform this check follow the procedure outlined in Section 11.2 of the LVP Maintenance Manual. If the ripple exceeds 400mv the Regulator Board (210-7597) should be replaced. This regulator card should be an "E" Rev. 7 or higher.

*Note: This power supply should be checked for the presence of ripple, before considering the replacement of a drive or controller.

CUSTOMER ENGINEERING
TECHNICAL ASSISTANCE CENTER
NEWSLETTER

#40110

4103

2200 SYSTEMS-MAINFRAMES-VP/MVP/LVP/SVP

TOPIC: FCO 1045 ON THE VP, LVP, MVP

Implementation of FCO 1045, released December 28, 1983, requires replacing the fan in the I/O section of 2200 chassis. Installation of a thinner fan provides accomodation for longer MXE boards. FCO 1045 documents ECO# 27336. To obtain the FCO Kit, place a routine order through the Logisitics Order Processing System for WLI 728-0063.

FAN 400-1029

DSDD SHUGART SA850/851

JUMPER SETTINGS

- A. Use the following assembly numbers found on the PC board of the drive to determine the necessary jumpers for 2200 or VS. This encompasses the latest drives.

	*****For 2200 LVP/SVP****			!	*****For VS-AWS*****		
Assembly No.	25189-2	25201-2	25216-0	!	25189-2	25201-2	25216-0
	25190-2	25202-3/2		!	25190-2	25202-3/2	

Jumpers (X=Installed)

850	X	X	X	!	X	X	X
IW	X	X	X	!	X	X	X
2S	X	X	X	!	X	X	X
DC	X	X	X	!	X	X	X
C TO HI	X	X	X	!	X	X	X
S2	X	X	X	!	X	X	X
IT	X	X	X	!	X	X	X
FM			X	!			X
MFM			X	!			X
RS	X	X	X	!	X	X	X
M	X	X	X	!	X	X	X
AF	*	X		!	*	X	

In position

4F cut

shunt at

positions 2/4 2/4 2/4 ! 2/4 2/4 2/4

*Install jumper from "F" to pin 11 on IC located at position 8D. IC at location 8D also needs pin 3 and 11 jumpered together.

- B. Unique Jumpers:

Jumper TS/FS

*****For 2200 LVP/SVP*****	!	*****For VS-AWS*****
FS	ON!	FS ? SEE TAB 20406 IB2 ON
DS2 (R drive of any 2 disk LVP/SVP)	!	DS2 ON
DS1 (IF only drive or for F drive)	!	
Remove terminator block at location 5E. (UNLESS ONLY DRIVE OR F DRIVE)	!	Insert terminator block at location 5E.
Remove wire from jumper 851 to pin 1 of IC-3F	!	Solder jumper wire from jumper 851 to pin 1 of the IC-3F
Insure etch in place between pin 8 of IC-3E and pin 1 of IC-3F.	!	The etch on the non-component side of the board between pin 8 of IC-3E and pin 1 of IC-3F must be cut.

FS FOR VS
TS FOR DIS

- C. Drive Configuration:

SA 850/851 configured for LVP/SVP, the WLN is 278-4015 (60 Hz).

SA 850/851 configured for LVP/SVP, the WLN is 279-4015-1 (50 Hz).

SA 850/851 configured for VS-AWS, the WLN is 278-4021 (60 Hz).

SA 850/851 configured for VS-AWS, the WLN is 278-4021-1 (50 Hz).

- D. 278-4015 and 278-4021 can be interchanged providing the proper jumpers on table A & B get implemented.

VS 25/45

Jumper settings for floppy

JUMPERS	PCB E-REV'S		
	25189-2/ 25190-2	25201-3/ 25202-3	25216-0
Y	X	X	X
850	X	X	X
IW	X	X	X
2S	X	X	X
DC	X	X	X
C to HI	X	X	X
S2	X	X	X
IT	X	X	X
FM			X
MFM			X
RS	X	X	X
M	X	X	X
AF	*	X	
In position 4F cut shunt at position	1/2/4	1/2/4	1/2/4
FS	X	X	X
DSI	X	X	X
Terminator at location 5E	In	In	In
Jumper from 851 to PIN 1 of IC 3F	Cut	Cut.	Cut

Must have short between pin 8 of IC 3E and Pin 1 of IC 3F.

X = Insert jumpers

* = Install jumper from F to pin 11 on IC located at position 8D. IC at location 8D also needs pins 3 and 11 jumpered together.

The 278-4015 (2200 configured), the 278-4021 (VS-AWS configured), and the 278-4028 (VS 25/45 configured) DSDD floppy drives are interchangeable by correcting the jumper settings. See newsletter 18 for 2200/VS AWS jumper settings. The last item in Table B of that newsletter should read pin 8 of IC 3E and not pin 2.

PRODUCT SERVICE NOTICE

DATE : 06/10/81

III	A	11	3-A
-----	---	----	-----

CLASSIFICATION PERIPHERALS

CATEGORY DISK DRIVES

PRODUCT/APPL. SHUGART SA850/851 DSDD DISKETTE

SEQUENCE # 3-A

TITLE:

2200LVP/SVP AND VS ARCHIVING WORKSTATION APPLICATIONS:
CIRCUIT BOARD PART NUMBERS AND JUMPER CONFIGURATIONS

NOTE

This PSN updates information originally presented in PSN III.A.11-3

The table below provides Shugart part numbers of the different circuit boards for the SA850/851 DSDD Diskette Drive. Except for the Wang jumper configurations detailed in this PSN, the various boards are compatible and interchangeable.

NOTE

The Shugart assembly number is stamped in black on the component side of the board; the fabrication (artwork) number is etched on the non-component side of the board.

<u>BOARD NOMENCLATURE</u>	<u>ASSEMBLY NO.</u>	<u>FABRICATION NO.</u>
MLC 10	25189-2	25188-0
MLC 10	25190-2	25188-0
MLC 11	25201-2	25200-1
MLC 11	25202-2	25200-1
MLC 12	25202-3	N/A

The following is a list of circuit board jumpers that must be connected to allow an SA850/851 DSDD Diskette Drive to operate with a Wang system.



LABORATORIES, INC.

ONE INDUSTRIAL AVENUE, LOWELL, MASSACHUSETTS 01851, TEL. (617) 459-6000, TWX 710 343-6769, TELEX 94-7421

PRINTED IN U.S.
REORDER NO
729-0917-A

Presently there are two different jumper configurations - one for LVP/SVP systems and one for VS-AWS's. The jumpers that are the same for both versions of the board are given first and the system dependent jumpers follow. Also refer to Figures 1, 2, 3, and 4 for jumper locations and positions. The part number for the jumper plugs is 350-4506.

The two Wang versions of the board have different part numbers--726-1913 for LVP/SVP use and 726-1913-M for VS-AWS use.

2200LVP/SVP & VS-AWS JUMPERS

850

IW (not connected to ground bus)

2S

DC

C to HI

S2

IT

RM to RS

M

AF (Only on boards MLC 11 and higher--located at board coordinates 7D)

2200LVP/SVP JUMPERS

FS

DS1 or DS2 (See following)

VS-AWS JUMPERS

TS (FS / Eco 22752)

DS2

If an LVP/SVP system includes both a diskette drive and a Winchester drive, DS2 must be jumpered. If the system has only a diskette drive, DS1 must be jumpered. If the system is an SVP containing two diskette drives, the "Fixed" (left) drive must have DS1 jumpered, and the "Removable" (right) drive must have DS2 jumpered.

The terminator block at location 5E must be installed for VS-AWS operation and removed for LVP/SVP operation.

For VS-AWS operation only, the etch on the non-component side of the board between pin 8 of IC 3E and pin 1 of IC 3F must be cut and a jumper wire connected from pin 851 to pin 1 of 3F (see Figures 2 and 4).

For both LVP/SVP and VS-AWS operation, the programmable shunt at location 4F must have HL and B open; all other jumpers in the shunt must be closed.

Board MLC 10 must have pins 3 and 11 of IC 8D jumpered together. (Pin 11 is connected to one end of jumper location F. See Figures 1 and 2.) This modification is required for both LVP/SVP and VS-AWS operation. On boards MLC 11 and higher, Shugart has provided a jumper (AF) and a NOR gate (5D) to eliminate the need for this jumper wire.

TOP

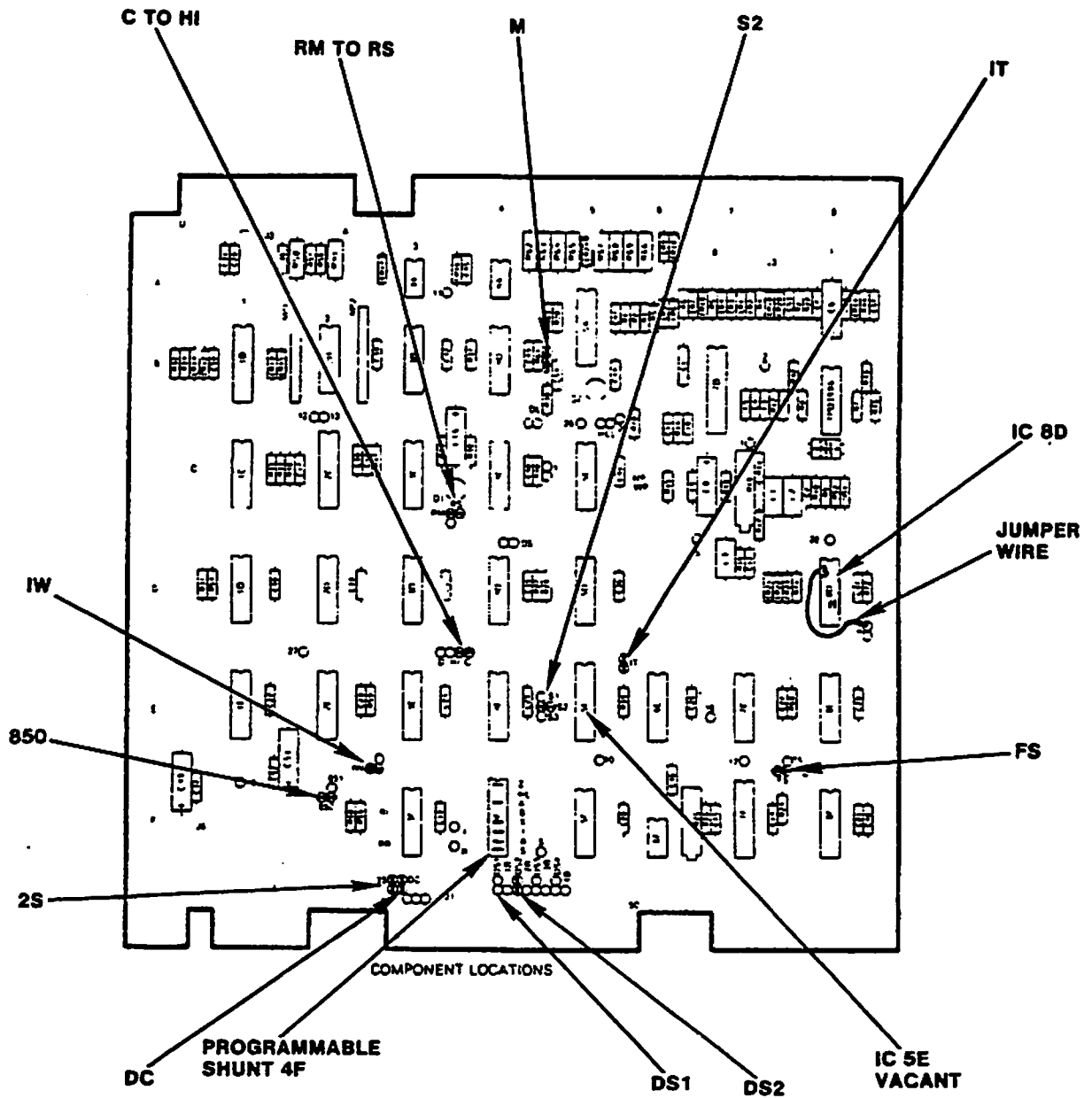

FIGURE 1 2200LVP/SVP JUMPER CONFIGURATION (MLC10).

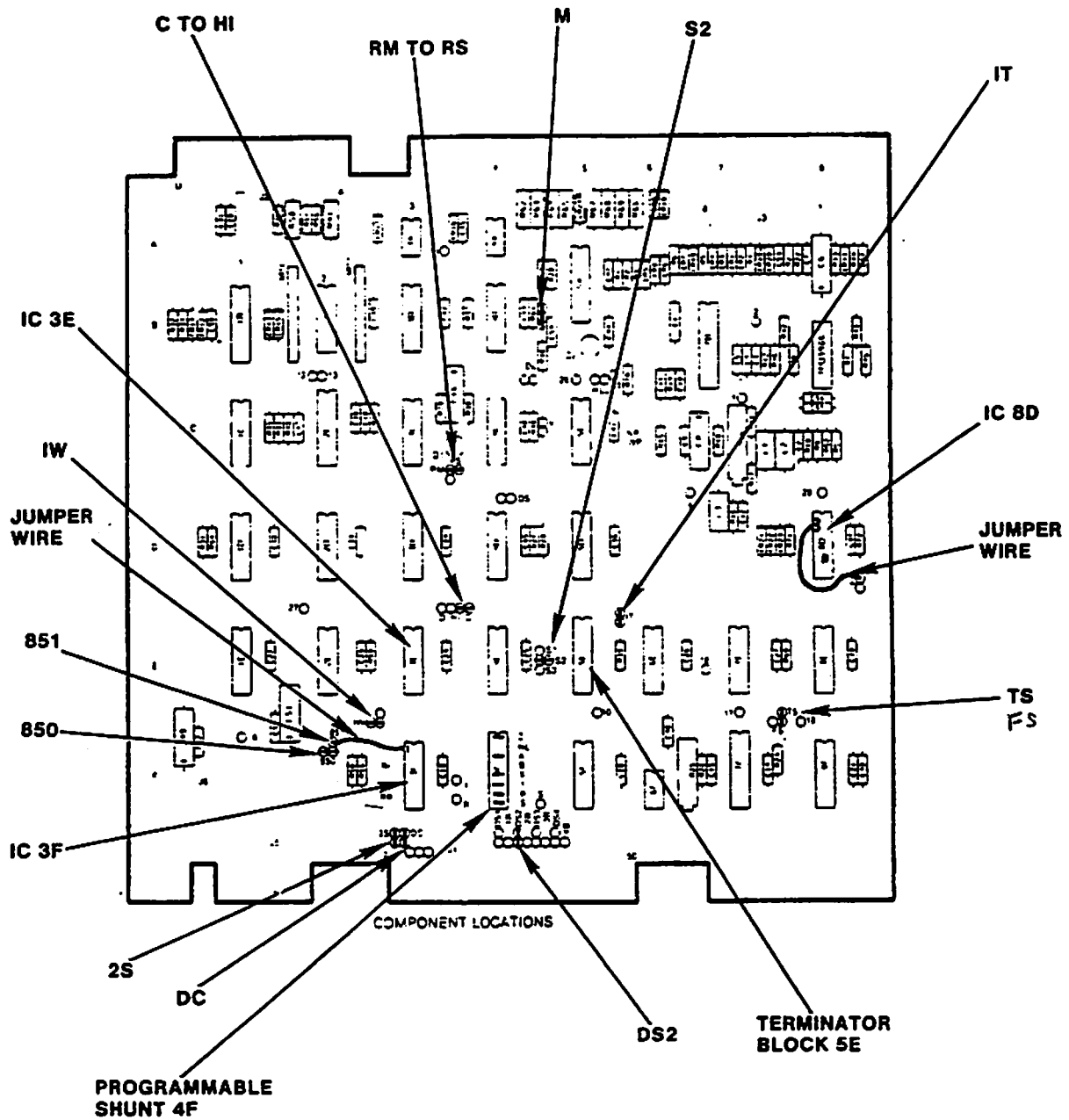

FIGURE 2 VS-AWS JUMPER CONFIGURATION (MLC10)

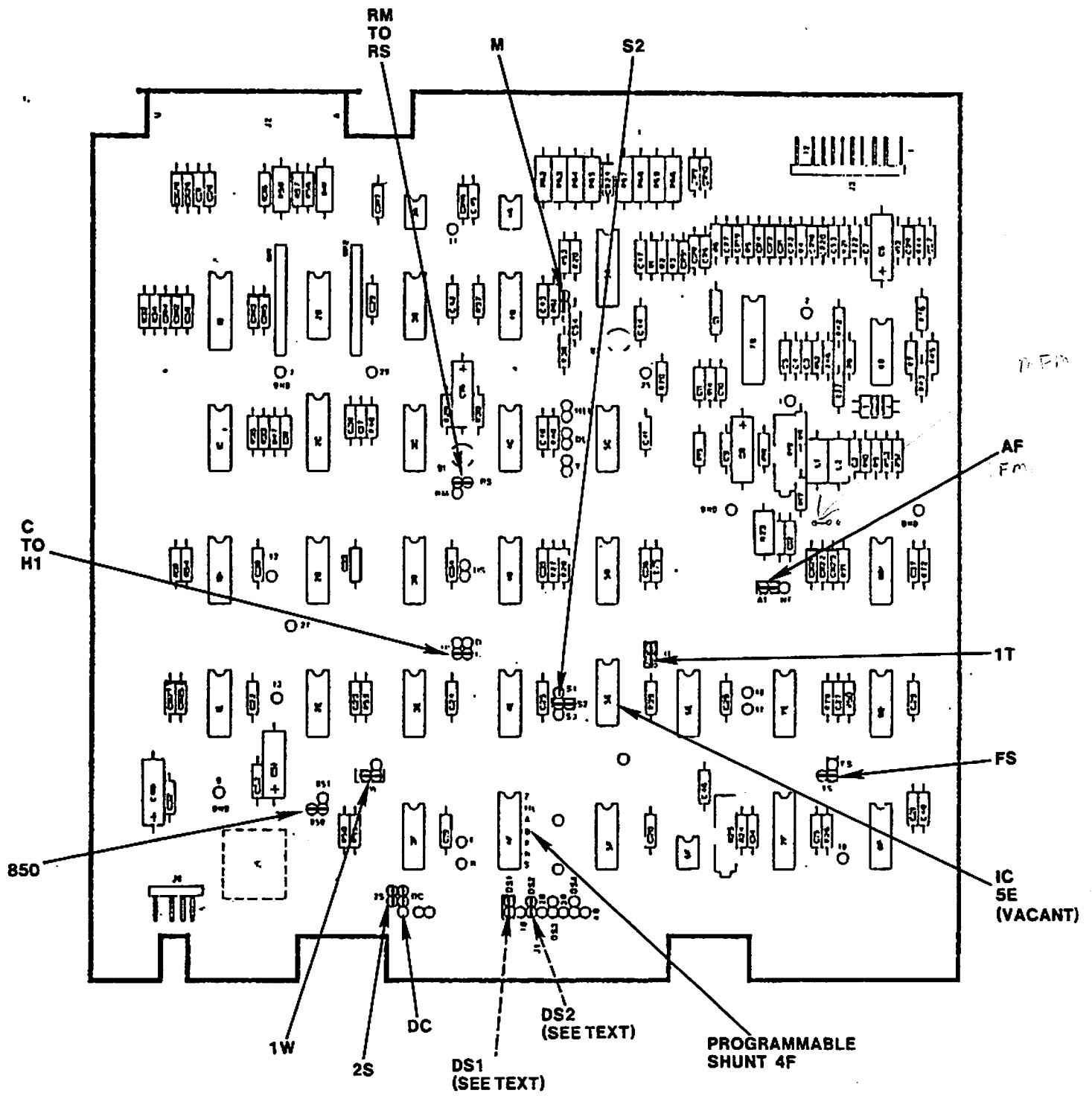

FIGURE 3 2200LVP/SVP JUMPER CONFIGURATION (MLC11)

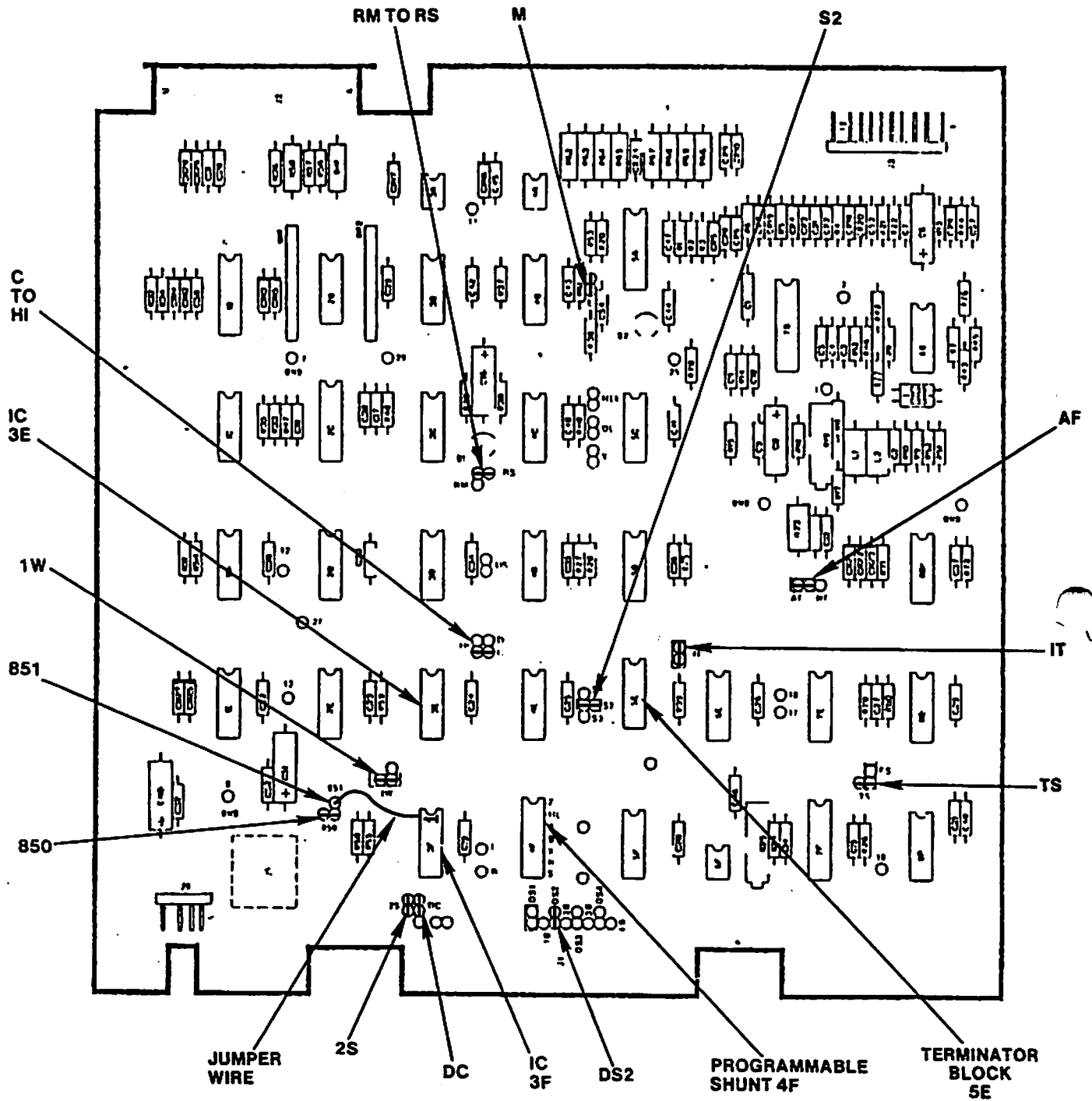

FIGURE 4 VS-AWS JUMPER CONFIGURATION (MLC11)

CUSTOMER ENGINEERING
TECHNICAL ASSISTANCE CENTER
NEWSLETTER

#30614

3101

PERIPHERALS-DISK DRIVES-SHUGART SA400/800/901/1000/4000

TOPIC: POSSIBLE WRITE FAULT CAUSED BY MULTIPLE HEADS SELECTED

Description of Change: The head select circuitry is susceptible to +24 volts noise. Capacitor C3 has been changed to 47uf, 35V in order to reduce the +24V noise level. The previous value of C3 was 4.7uf, 35V. Affects PCB 26073-5 and lower revision.

CUSTOMER ENGINEERING
TECHNICAL ASSISTANCE CENTER
NEWSLETTER

#30614

3101

PERIPHERALS-DISK DRIVES-SHUGART SA400/800/901/1000/4000

TOPIC: PROPER WAY TO POSITION THE HEADS BEFORE REMOVING DRIVE FROM SYSTEM

Physical Drive Interface:

- J1 - Provides control signal for the drive.
- J2 - Provides for the radial connection of Read and Write signals.
- J4 - Provides the AC power needed for the drive motor.
- J5 - Provides DC power for the electronics and the stepper motor.

If the drive needs to be replaced, turn the AC power off from the host system. On the drive disconnect J1, J2, and J5 without disconnecting the AC power (J4) from the Winchester Drive. Turn on the AC power from the host system and manually move the heads into the innermost tracks. This procedure reduces the likelihood of head bounce during shipment. Disconnect AC power and finish installing the spindle lock.

PRODUCT SERVICE NOTICE

DATE : 1/14/82

CLASSIFICATION PERHIPERALS

CATEGORY DISK DRIVES

PRODUCT/APPL. SHUGART SA1000 WINCHESTER DRIVES

SEQUENCE # 3

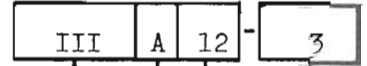

TITLE :

SHUGART SA1000 DISK DRIVE OPTIONS JUMPERS

Some SA1000 "Winchester" disk drives are being received at the Lawrence stock room from Shugart Associates with the options jumpers installed incorrectly. These jumpers are on the 26051 Control PCB (WLI #726-1907). It is vital that these options jumpers be verified when a replacement drive is installed in the field. Remove or install the jumpers as described below. Refer to Figure 1 for jumper locations.

1. Fault - When removed, enables the Fault Detection logic. This jumper should be REMOVED.
2. Ready - When removed, enables the Ready signal at the interface. This jumper should be REMOVED.
3. Drive Selection - Selects the disk drive number 1 through 4. INSTALL this jumper for the correct drive number as shown in figure 2.
4. Interface Voltage Selection - Selects the correct interface voltage. INSTALL this jumper for the -5 Volt dc configuration for Wang systems as shown in figure 3.

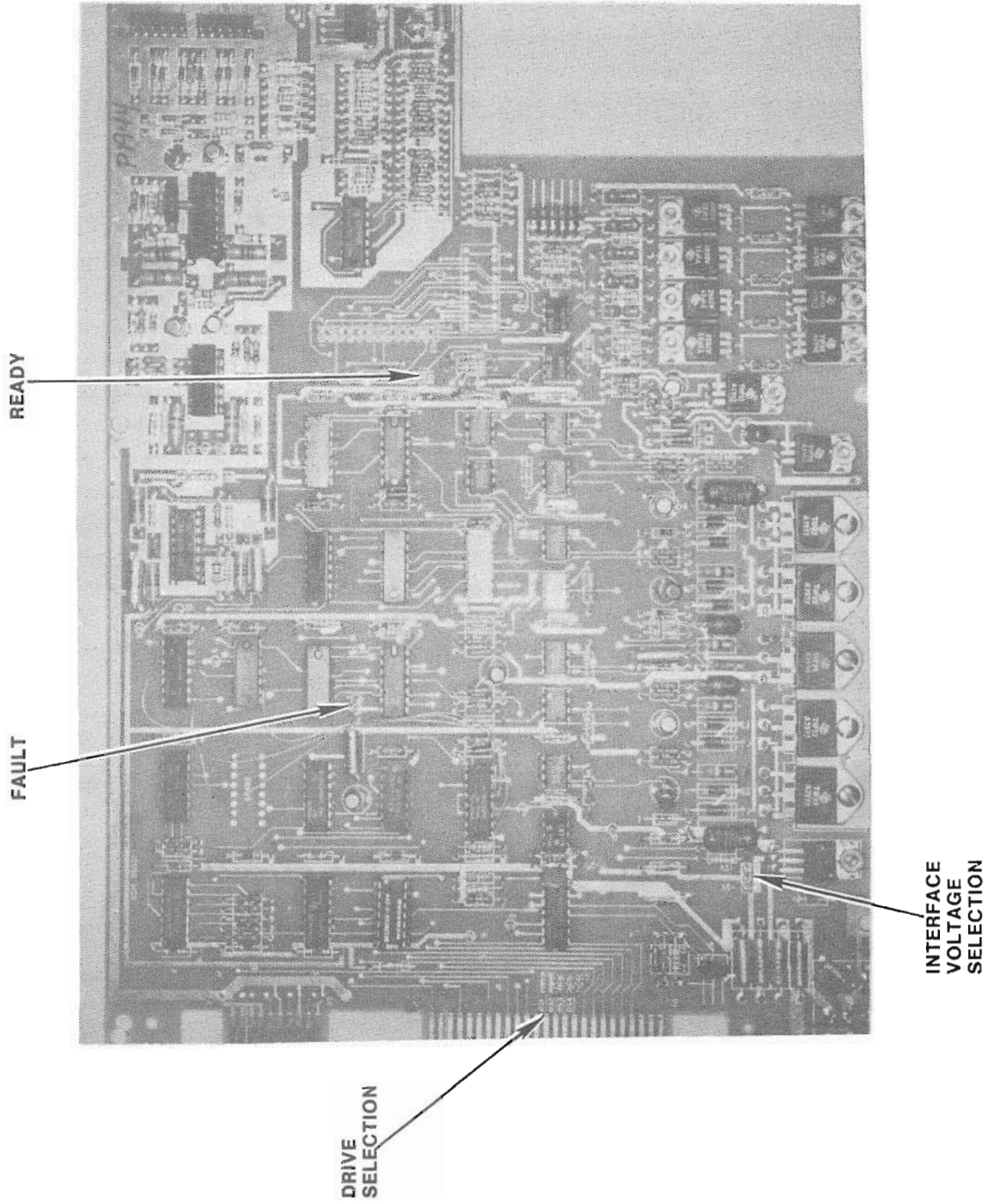

FIGURE 1
26051 CONTROL BOARD

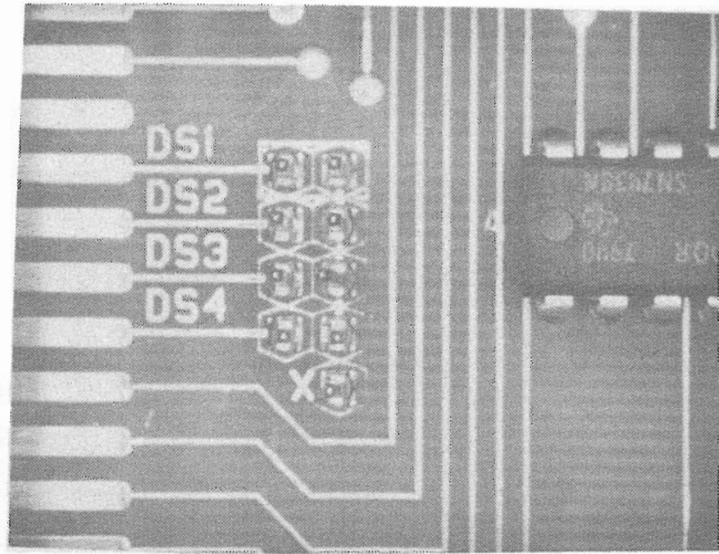

FIGURE 2
DRIVE SELECTION (DS1-4)

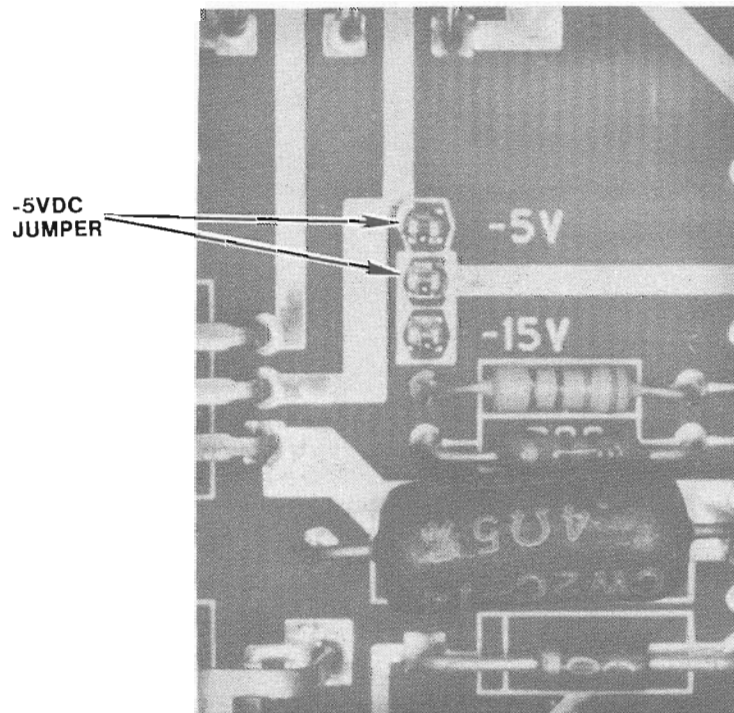

FIGURE 3
-5 VOLT INTERFACE VOLTAGE SELECTION

WANG

FIELD CHANGE ORDER

FCO NO.
1007

Equipment Affected 2200 SVP/LVP (SINGLE BOARD WINCHESTER)
 Class NEXT CALL FCO Kit # 728-0017 Page 1 of 7
 Org. Code III.A.12 FCO Doc. # 729-1128 Approval Date:
 Est. Install. Time 45 MINUTES Ref. ECO # SHUGART 3385 AUG 12 1982

NOTE: IN ORDER TO RECEIVE COMPENSATION FROM SHUGART FOR INSTALLATION OF THIS CHANGE, PLEASE DETACH PAGE# 7, FILL OUT THE INFORMATION REQUIRED, AND MAIL. (ADDRESS IS CONVENIENTLY PRINTED ON REVERSE SIDE OF PAGE# 7)

1. REASON FOR CHANGE

To provide a valid "SEEK COMPLETE" signal to the controller.

2. DESCRIPTION OF CHANGE

This change incorporates eight jumpers and two etch cuts (PCB# 26073-5) in order to perform AND operation on "SEEK COMPLETE" and "TRK00" signals.

3. DOCUMENTATION AFFECTED

N/A

4. PREREQUISITE (S)

Shugart Single Board Winchester Disk Drives in the 2200 SVP/LVP are the only units which require this change (WL# 278-4013/14 with PCB# 26073-5). Units that require the change will have a LSI (Large Scale Integration) chip in location 3C. (See Illustration C)

5. INSTALLATION PROCEDURE

- A. Remove top cover of 2200 LVP/SVP unit.
- B. Remove the two bolts which attach the drive to the chassis frame, and save.
- C. Disconnect the two ribbon cables and two power cables from the drive.
- D. Remove the Winchester Disk Drive from system.

Product Support <i>Charles Haggerty</i> 8-12-82	Logistics <i>Kevin Andrews</i> 8/12/82	Originator <i>Blaine O'Donnell</i> 8-12-82	FCO Coordinator <i>John Brock</i> 8/12/82
--	---	---	--

ILLUSTRATION "A"

NON-COMPONENT SIDE

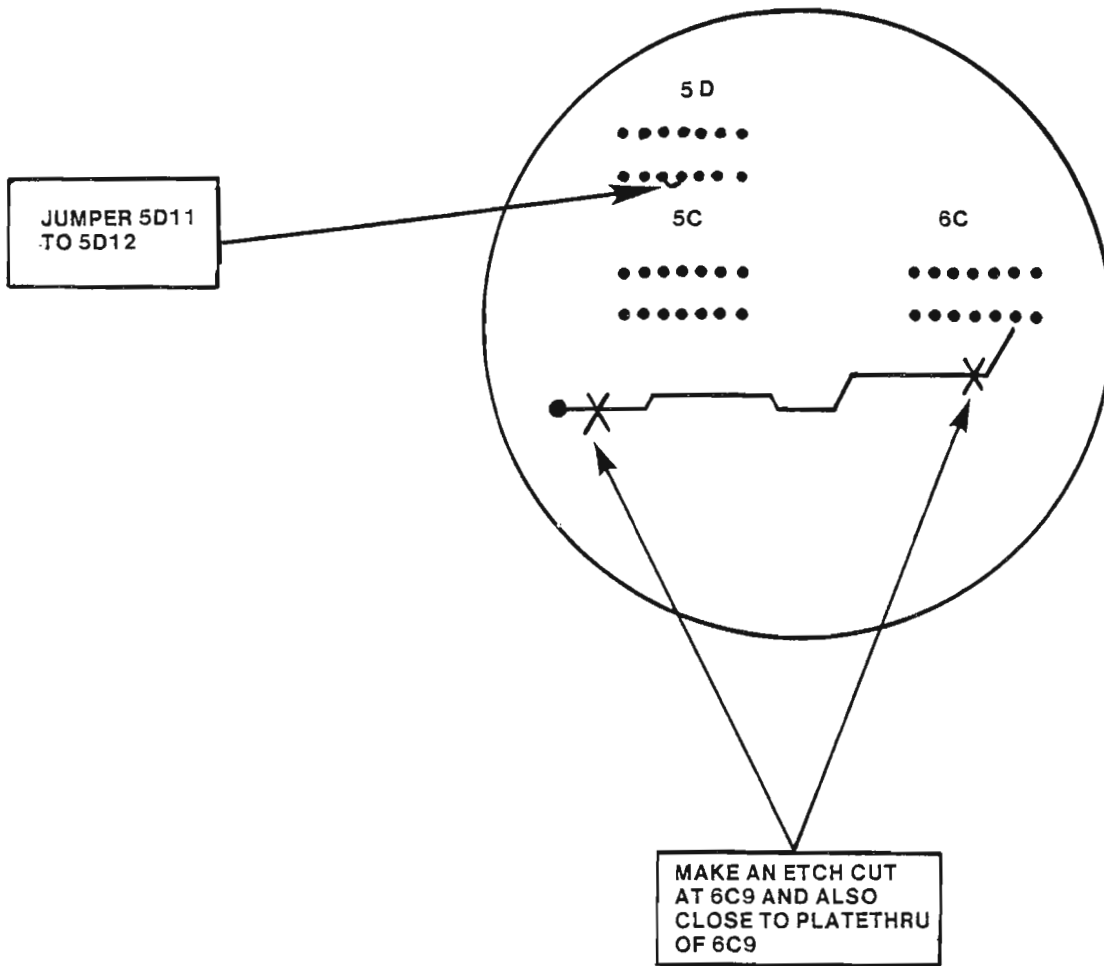

ILLUSTRATION "B"

COMPONENT SIDE

JUMPER 7D6
TO 6C9

JUMPER 7D4 TO
PLATETHRU THAT
CONNECTS TO RES
AT RIGHT OF
LOCATION 5B

JUMPER 5D9
TO 7D5

JUMPER 5D12
TO +OV AT 5D7

JUMPER 5D13
TO PLATETHRU
CONNECTED TO
5C8

JUMPER 5B5
TO PLATETHRU
CONNECTED TO
6C1

JUMPER 5B6
TO 5D10

PCB# 26073-5

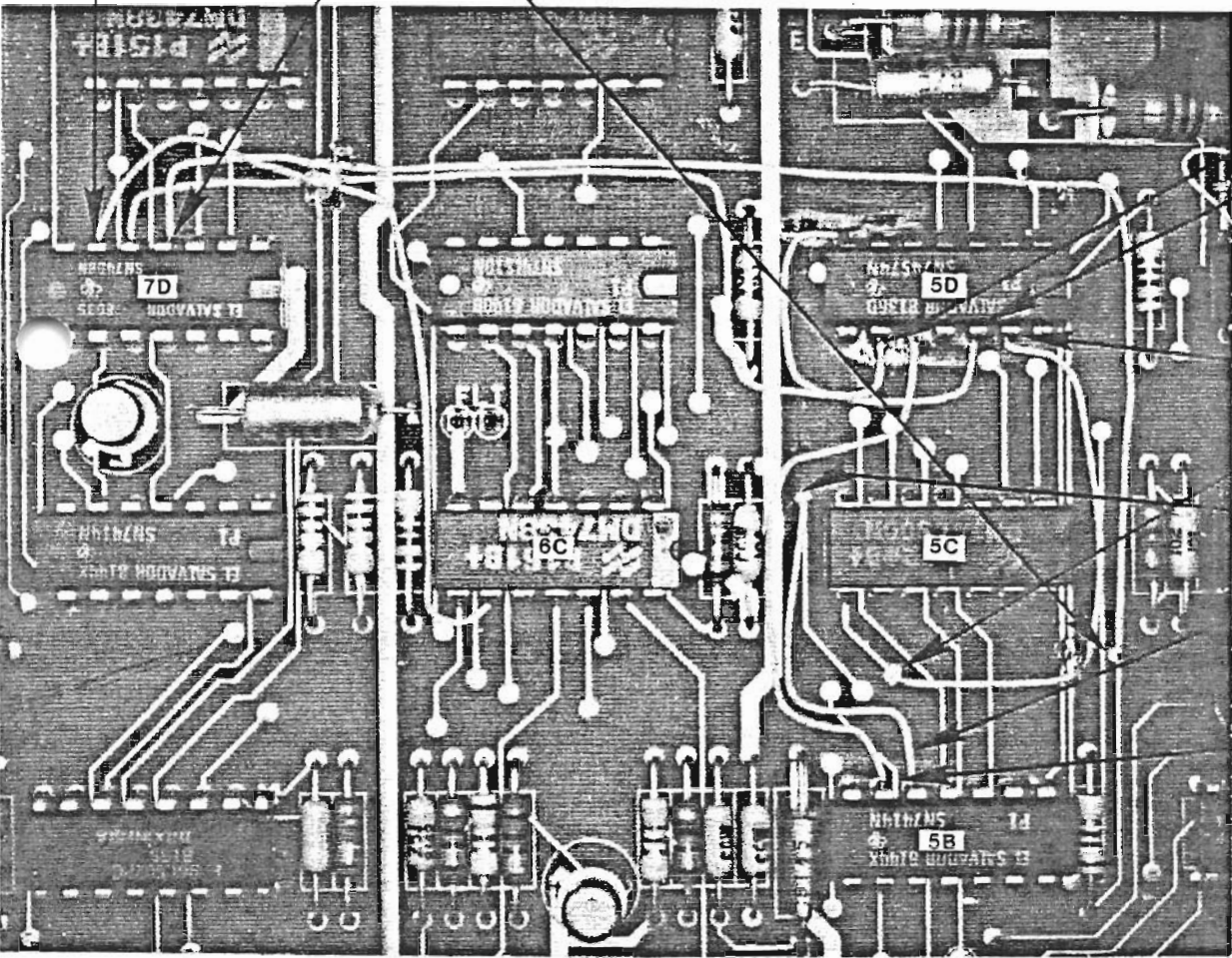
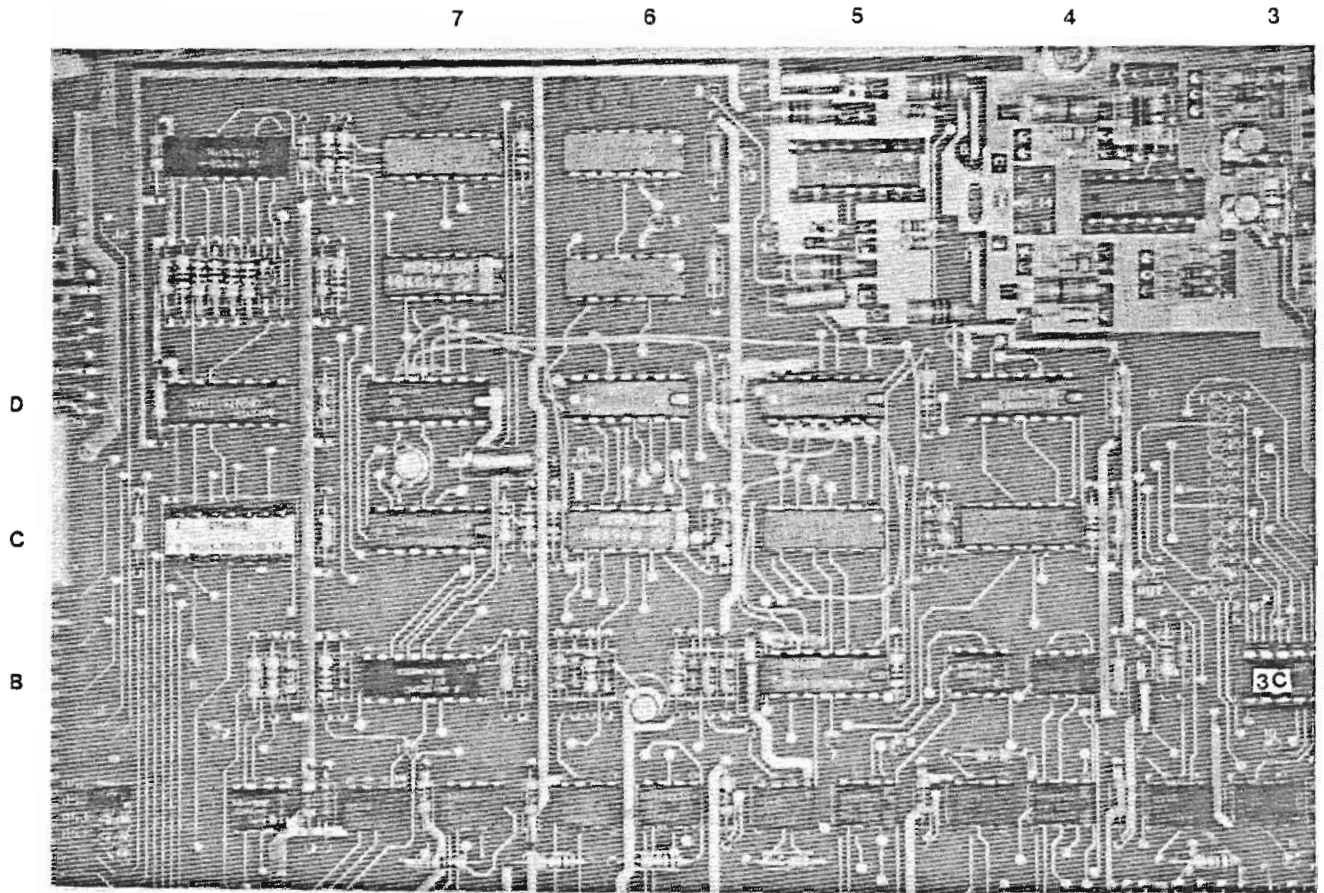

ILLUSTRATION "C"



5. INSTALLATION PROCEDURE (CONT.)

- E. In order to gain access to the non-component side of the 26073-5 board, remove the screw that attaches it to the drive, and save. Rotate the nylon locking devices to a vertical position. Detach board. Disconnect index sensor cable, positioning motor cable and read/write head cable.

NON-COMPONENT SIDE

- F. Make an etch cut at 6C9 and also cut the same etch close to platethru of 6C9. (See Illustration A)
- G. Jumper 5D11 to 5D12. (See Illustration A)

COMPONENT SIDE

NOTE: Keep wires as close as possible to PCB. Use Illustration B except where specified.

- H. Jumper 5B5 to platethru connected to 6C1.
- I. Jumper 5B6 to 5D10.
- J. Jumper 5D9 to 7D5.
- K. Jumper 5D12 to +0V at 5D7.
- L. Jumper 5D13 to platethru connected to 5C8.
- M. Jumper 7D4 to platethru that connects to the resistor at the right of location 5B.
- N. Jumper 7D6 to 6C9.
- O. After installation of this change, cross out the previous ECO# stamped on the bottom left corner of the PCB and mark the board with ECO# 3385.
- P. Remount board to drive with screw saved from Step E. Turn nylon locking devices to horizontal positions and reconnect cables as described in Step E.
- Q. Secure drive to chassis frame using the two bolts saved from Step B.
- R. Turn on power.
- S. After testing system integrity, turn off power and reinstall the top cover.

6. CHECK-OUT PROCEDURE

The "power up" diagnostics for the 2200 SVP/LVP system (Step R of Installation procedure) will be sufficient to test system integrity following the installation of this change.

7. FCO KIT PARTS LISTING

<u>Item #</u>	<u>Item Description</u>
WL# 729-1128	FCO# 1007
WL# 600-5009	5 ft. jumper wire (30 gauge)

8. FCO KIT AVAILABILITY DATE

FCO Kit # 728-0017 will be available August 23, 1982. It can be obtained by placing a routine order through the Logistics Order Processing System.

9. REMOVED PARTS DISPOSITION

N/A

10. MISCELLANEOUS

If the Shugart Winchester Single Board Disk Drives of the OIS system are interchanged with the 2200 SVP/LVP system, this change must be incorporated in order to ensure compatibility.

FCO# 1007

Page 7 of 7

FOLD

DRIVE SERIAL NUMBER _____

Indicate which drive type was updated by placing an "x" in one of the locations below.

WL# 278-4013 _____

WL# 278-4014 _____

FOLD

PLEASE BE SURE TO FILL OUT THIS PAGE

THIS INFORMATION IS NECESSARY IN ORDER FOR WANG TO RECEIVE COMPENSATION FROM SHUGART FOR INSTALLATION OF THIS CHANGE.

FOLD ALONG DOTTED LINES AND MAIL.

ADDRESS IS CONVENIENTLY LOCATED ON REVERSE SIDE OF THIS SHEET.

WANG LABORATORIES, INC.
437 SOUTH UNION STREET
LAWRENCE, MASSACHUSETTS 01843

ATTN: John Proulx M/S 8236A

WANG LABS INC.
BURLINGTON, MA
ATTN: Branch Manager

RDB 3114
(Qty 1)

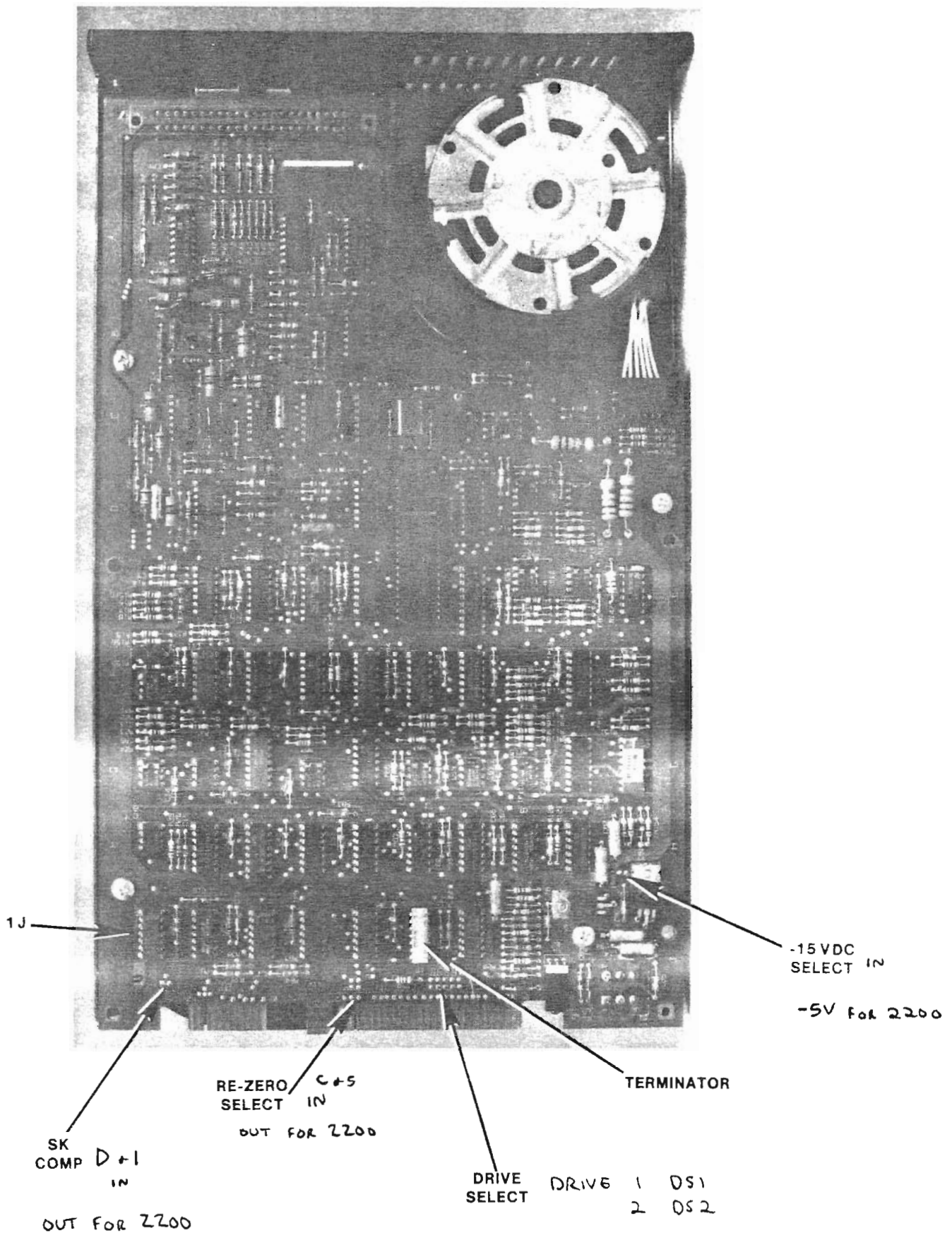

Figure 5-29. Quantum Drive Jumper Options

LVE/SVP_Winchester_Drive

Prevent Head/Surface Damage

To prevent damage to head and/or surface it is important that the heads be positioned at the innermost track and the spindle lock bracket attached. This can easily be done by verifying the last sector on the disk before power off.

VERIFYF (8127,8127)	2 MEG	278-4013
VERIFYF (16319,16319)	4 MEG	278-4013
VERIFYF (32639,32639)	8 MEG	278-4014

If not responsive to the VERIFY statement, after the unit has been on for 2 minutes rotate the damper assembly clockwise only to the 2 o'clock position using the track 0 detector as 6 o'clock, then power down and insert spindle lock.

JUMPERS

There are three jumpers on the Winchester drive.

DS1	Located beside I/O cable J2
5V	Located 1 1/2" up and 1 1/2" in from the bottom right corner.
Terminator	IC located at location C8

CUSTOMER ENGINEERING
TECHNICAL ASSISTANCE CENTER
NEWSLETTER

#30628

3101

PERIPHERALS-DISK DRIVES-SHUGART SA400/800/901/1000/4000

TOPIC: NEW SHUGART SA-1000 BRACKET

Wang has stopped using the Wang Manufactured Bracket, and is now using the bracket supplied by Shugart on all new SA-1000 Winchester drives. The major differences are:

- A. Wang Manufactured Bracket- protects the drive and incorporates the base plate as a mount to secure drive into the SVP/LVP and OIS system.
- B. Shugart Bracket- only protects the drive. To install the unit into the system the following parts are required.

<u>Description</u>	<u>WLN</u>
Drive Plate	452-4310
Foot Holder	449-0420
Screw	650-3120

If an exchange is required and the drive brackets do not match, replace the brackets between the units. Replacing the brackets does not take more than five minutes.

CUSTOMER ENGINEERING
TECHNICAL ASSISTANCE CENTER
NEWSLETTER

#30412

3101 (III.A.12)

PERIPHERALS-DISK DRIVES-SHUGART SA-1000 8" WINCHESTER

TOPIC: SA-1000 NEW BRACKET

Manufacturing is not using the old Wang filter bracket anymore. The new bracket is supplied by Shugart on their standard product. To do this, the old filter bracket had to be redesigned so that it could be relocated to the bottom mounting plate within the various CPU's.

<u>Description</u>	<u>WLN</u>
Old Filter (Parts and Bracket)	279-0483
New Filter (Parts and Bracket)	270-0790

Old and new filters use the same part, the only difference is that they are mounted in different brackets.

CUSTOMER ENGINEERING
TECHNICAL ASSISTANCE CENTER
NEWSLETTER

#20302

IV.A.3

2200 SYSTEMS-MAINFRAMES-VP/MVP/LVP CPU'S.

TOPIC: 210-8696 SWITCH SETTINGS

The LVP-C uses the Quantum Winchester. The switch settings for the 210-8696 PCA are:

Switch Settings	#2	#4	#8	
	1	1	1	No Fixed Drive
	1	0	1	Small Fixed-
				210-8696-B = 2-Meg Shugart
				210-8696-A = 4-Meg Shugart
	0	1	1	8-Meg Fixed Shugart
	1	1	0	16-Meg Fixed Quantum
	0	1	0	32-Meg Fixed Quantum

Switch Number #6

1 = No Floppy installed
0 = Floppy installed

Switch Number #3 = OFF

All other switches should be in the 'ON' position.
(1 = ON & 0 = OFF)

CUSTOMER ENGINEERING
TECHNICAL ASSISTANCE CENTER
NEWSLETTER

#10113

III.A.12

PERIPHERALS-DISK DRIVES-SHUGART SA-1000 8" WINCHESTER

TOPIC: ERRORS ON WINCHESTER DRIVES USED ON LVP - ECO.

If you are experiencing I-93 errors or format errors on the winchester drives, 278-4013 (-1 50 Hz), 278-4014 (-1 50 Hz) add an 820pf ceramic disk capacitor (WLI P/N 300-1820) in parallel with R83 (6.2K) on the control circuit board (larger board) between chip 7A₂ (LM311) and chip 8A (7438), approximate board coordinates 8A.

The capacitor should be adequately mechanically secured to the resistor lead (wrap capacitor leads around resistor leads) then solder together.

This ECO should also be done to all winchester drives in stock and drive PCB's (726-1902) before installing in systems.

The ECO should be done immediately to all winchester drives and PCB's in stock, and on a next-call basis or as required in the field.

This ECO eliminates noise on the trailing edge of the comparator output pulse, which in turn eliminates an undesired second index pulse from one shot 96LS02.

X/X/80

I B 2 X

GENERAL INFORMATION

TECHNICAL

EQUIPMENT CONVERSION INFORMATION

X

MODEL 2200LVP CENTRAL PROCESSING UNIT:
DATA-MEMORY AND FIXED-DISK DRIVE CAPACITY CONVERSIONS

This PSN contains information needed to order, install, and check out 2200LVP Data-Memory and Fixed-Disk Drive capacity conversion kits. Section 1 covers the Data-Memory upgrade, and includes kit numbers and conversion procedures. Section 2 contains kit numbers and conversion procedures for the Fixed-Disk Drive upgrade.

1. DATA-MEMORY CAPACITY

DATA-MEMORY CAPACITY CONVERSION KITS

<u>CONVERSION DESCRIPTION</u>	<u>CONVERSION KIT MODEL #</u>	<u>CONVERSION KIT PART #</u>	<u>PARTS SUPPLIED IN CONVERSION KIT</u>	<u>PARTS REPLACED BY CONVERSION KIT</u>
32K to 64K	V3264	WL #200-VP3264	WL #210-7587-1A	WL #210-7587-1B
32K to 128K	V32128	WL #200-0307	WL #210-7587-3A	WL #210-7587-1B
64K to 128K	V64128	WL #200-0313	WL #210-7587-3A	WL #210-7587-1A

To change the Data-Memory capacity of a 2200LVP CPU, power-down the system, remove the Data-Memory board presently in the the CPU, and replace that board with the one supplied in the conversion kit. (The location of the Data-Memory board, as well as the RAM loading for the various capacity boards, is shown in SECTION 8 of Model 2200LVP Maintenance Manual, IV.A.3.M., WL #729-XXXX). After the conversion is completed, run the Data-Memory diagnostics (refer to documentation category IV.C.1) to ensure complete operation of the CPU.

2. FIXED-DISK DRIVE CAPACITY

FIXED-DISK DRIVE CAPACITY CONVERSION KITS

<u>CONVERSION DESCRIPTION</u>	<u>CONVERSION KIT MODEL #</u>	<u>CONVERSION KIT PART #</u>	<u>PARTS SUPPLIED IN CONVERSION KIT</u>	<u>PARTS REPLACED BY CONVERSION KIT</u>
2MB to 4MB	UJ6001	WL #206-6001	WL #278-4013(-1)	WL #278-4018(-1)
2MB to 8MB	UJ6003	WL #206-6003	WL #278-4014(-1)	WL #278-4018(-1)
4MB to 8MB	UJ6005	WL #206-6005	WL #278-4014(-1)	WL #278-4013(-1)

X/X/80

IV B 1 X

2200 SYSTEMS

INTERFACE

I/O CONTROLLERS

X

MODEL 22C32 (WL #212-3012) TRIPLE CONTROLLER:
GENERAL DESCRIPTION, SWITCH SETTINGS, AND FIRMWARE (PROM) LOADING

The Model 22C32 Triple Controller is an I/O option available for the 2200VP/LVP/MVP product line, and is capable of supporting a 2236D/DE terminal, any 2200 series disk drive, and a printer.

The disk and printer portions of the 22C32 controller logic are similar to existing disk and printer interface controllers (22C12 and 22C13 disk controllers excluded).

The terminal portion of the 22C32 controller logic handles I/O operations between a 2236D/DE terminal and CPU, and acts as a buffer for data transmitted between the terminal and the VP/LVP/MVP CPU. With the controller managing these tasks, the CPU is free--under the control of the Operating System--to execute a program and to monitor the operations of other system peripherals. Communication between the terminal and the controller is asynchronous, full-duplex, with a fixed baud rate of 19.2K. Data is transferred between the terminal and controller through an EIA RS-232-C or CCITTV.24-compatible cable.

Because the terminal portion of the 22C32 can operate along with one (2200LVP application), two or three 2236MXD multiplexers/controllers (2200MVP application), which support up to four 2236D/DE terminals each, an LVP system with a 22C32 can support a maximum of five 2236DE terminals, and an MVP system with a 22C32 can support a maximum of thirteen 2236D/DE terminals. (See chart below.)

A VP system with a 22C32 can support one 2236D/DE terminal (replacing the 2226 console).

NOTE:

Only one 22C32 can be installed in any system.

PRESENT ALLOWABLE SYSTEM CONFIGURATIONS

2200 CPU	<u>VP</u>	<u>LVP</u>	<u>MVP</u>
No. of 22C32 Controllers	1	1	1
No. of 2236MXD Controllers	0	1	1, 2, or 3
No. of Terminals in System	1	5	5, 9, or 13

The 22C32 triple controller (WL #212-3012) consists of two circuit boards (occupying only one CPU I/O slot): a WL #210-7515 motherboard containing the printer and disk interface electronics, and a WL #210-7516A daughterboard containing the Z80-based 2236D/DE interface electronics.

The firmware for the terminal portion of the 22C32 is contained on the WL #210-7156A board and consists of two PROM's: #1 (WL #378-4092) in location L17, and #2 (WL #378-4093) in location L18 (ref: FIGURE 2).

The address of the terminal portion of the 22C32 is selected by means of a five-section switchbank (SW1) located on the WL #210-7515 board (ref: FIGURE 1). The chart below shows the proper switch settings for one, five, nine, and thirteen-terminal systems.

<u>NUMBER OF TERMINALS</u>	<u>SWITCH SETTINGS*</u>					<u>DEVICE ADDRESS</u>
	<u>S-5</u>	<u>S-4</u>	<u>S-3</u>	<u>S-2</u>	<u>S-1</u>	
One	0	0	0	0	1	HEX(00)
Five**	0	1	0	0	1	HEX(40)
Nine***	1	0	0	0	1	HEX(80)
Thirteen****	1	1	0	0	1	HEX(C0)

* 0 = OFF; 1 = ON. S-1 is the terminal enable switch--it is always set ON; S-2 through S-5 are the terminal device address switches.

** One 2236MXD and one 22C32 (LVP and MVP systems)

*** Two 2236MXD's and one 22C32 (MVP system only)

**** Three 2236MXD's and one 22C32 (MVP system only)

Both the printer and disk addresses are switch-selectable by means of two 8-section switchbanks (SW2 and SW3) located on the WL #210-7515 board (ref: FIGURE 1). SW2 selects the printer address (normally HEX 215 or 216) and SW3 selects the disk address (normally HEX 310, 320 or 330) . Refer to PSN IV.B.1-X for the proper setting of these device address switches.

00086

No category established yet

X/X/80

IV

C

4

1

2200 SYSTEMS

SOFTWARE

OPERATING SYSTEM

1

2200MVP OPERATING SYSTEM RELEASE 1.9: DESCRIPTION

Release 1.9 of the 2200MVP Operating System (WL #701-2294K), which replaces all previous MVP O.S. releases, is now available. Release 1.9 provides all MVP systems with several new features and corrects all known system anomalies. The system enhancements incorporated with Release 1.9 pertain to the following topics:

- Number of terminals allowed on an MVP system
- System Utilities
- LIST D command
- LOAD RUN command
- LIST DT command
- KEYIN statement

The Operating System files that have changed since O.S. Release 1.8 are listed below.

@@ - MVP O.S. & BASIC-2 Language Processor
@2273VUFU - 2273 Vertical Format Control Utility (new)
@MENU - Program Menu Utility (new)
.SYSMVFB - Menu Mode Data (new)
.STARTD - Menu Root Mode Pointer (new)
@PSTAT - Partition Status Utility
@MOVE - Move System Files Utility (new)
@FORMAT - Format Disk Platter Utility (new)

A. SYSTEM ENHANCEMENTS

Number of Terminals Allowed

With the incorporation of O.S. Release 1.9, the 2200MVP can support up to thirteen (13) 2236D/DE Interactive Terminals. This is accomplished by allowing for a third 2236MXD Multiplexer/Controller to be used (along with one 22C32 Triple Controller).

There is one prerequisite for increasing the number of terminals on a system to 13--an MVPA chassis is required. Refer to Model 2200MVP Maintenance Manual, CE #03-0071-1 (IV.A.3), Section 8 for information concerning the MVP-to-MVPA conversion procedure.

System Utilities

The utilities described below can be accessed by entering LOAD RUN (RETURN) on the "system console" keyboard. This action loads a START program which overlays (loads) a menu (@MENU) providing access to the utilities. Certain utilities are for particular devices and do not have a function in all 2200MVP configurations.

@MENU: Utility Menu

@MENU provides a tree-structured menu for utility selection. Multiple levels of menu can be set up with each successive screen displaying the next menu mode. (See @MENU program REMarks for customization).

@GENPART: Partition Generation

This utility creates, saves, and executes system configurations which divide the 2200MVP resources among the system users. (See 2200MVP Maintenance Manual, CE #03-0071-1 (WL #729-XXXX), IV.A.3).

@PSTAT: Partition Status

This program displays the current status of each partition in the current 2200MVP configuration. The Partition Status Utility has been revised to use less CPU time, and to provide better prompting for attaching the terminal to another partition. (See \$PSTAT in the 2200VP BASIC-2 Language Reference Manual, WL #700-4080C, IV.C.2.)

@MOVE: Move System Files

This utility moves specified system files from one disk platter to another.

@FORMAT: Format Disk Platter

This program formats software-formattable disk platters, such as 2250C, 2260BC and 2280 platters. (Refer to the appropriate disk user reference manual for detailed formatting information.)

@2273VFU: 2273 Vertical Format Control

This utility defines 2273 Band Printer vertical format control sequences. (See Section C of this PSN for an explanation of this utility.)

LIST D Command

The LIST D command now marks all program lines that are explicitly referenced by line number within the program. A minus sign (-) is displayed before the line number of any referenced line.

LOAD RUN Command

The LOAD RUN command is now programmable, and can be used to clear out an executing program and load in another program. The LOAD RUN command has the advantage over the LOAD command in that program dependent parameters, including program protect, are cleared.

LIST DT Command

The LIST DT command now includes the terminal printer (address 204) in the list of devices in the current configuration.

KEYIN Statement

The response time for programs inputting keystrokes with the polling form of KEYIN (i.e., KEYIN, line #, line #) has been improved.

B. CORRECTED ANOMALIES

1. Certain types of 2280 disk errors (e.g., illegal sector address (I98), or disk in LOAD mode (I91)) could cause the wrong sectors to be reported in error during VERIFY operations.
2. VERIFY operations did not set the ERR function if an error was detected.
3. If a LINPUT request, whose entry field was underlined and wrapped from one CRT line to the next, was terminated by a special function key, subsequent PRINT output to the CRT could be interspersed with display of the non-underlined LINPUT data.
4. Printing a numeric value in exponential format with PRINTUSING could produce incorrect output if the number of digits specified in the image was greater than 13.
5. An access conflict occurred when simultaneous printing was done to printers attached to terminals 1 and 9, 2 and 6, 3 and 7, or 4 and 8. The second printer inadvertently would be locked out by the first printer's operation.
6. LIST T could use more than its share of CPU time if there were no references to the item being searched for.
7. Halt/stepping a multi-statement line containing a LIST V statement could cause previously executed statements to be re-executed.
8. The MAT SEARCH and RESTORE statements could use more than their share of CPU time; RESTORE may now breakpoint, rather than always executing without interruption.
9. Spaces in the value of an alpha variable used for device selection in a SELECT statement were ignored, but should have been reported as an ERR 17.

10. The EXP function caused the ROUND/NOROUND flag to be reset to the ROUND state. The code now will restore the flag to the selected state.
11. Using the same array as both a receiver and an operand in a MAT multiply or transpose statement was not reported as an error. Furthermore, using a global array and local array which had the same name letter (and digit) was incorrectly reported as an error.
12. It was possible that executing numeric MAT statements which referred to global arrays in another partition could cause the system to hang up, requiring the system to be powered off and back on to restore system operation.
13. If an error occurred while opening a data file with a device table slot that already had a file open, the previous file would not be closed.

C. OPERATOR INSTRUCTIONS FOR THE 2273 VERTICAL FORMAT CONTROL UTILITY

When the 2273 Vertical Format Control Utility is selected from the utility menu, the following text appears on the screen:

2 2 7 3 D A V F U D A T A P R E P A R A T I O N

Purpose:

This program facilitates the preparation of 2273 DAVFU format data when the FLS (Forms Length Selector) is inadequate for forms control. Note, however, that the FLS (Forms Length Selector) is more convenient for most printing.

Format data can be created, edited, and saved on disk for later loading into the DAVFU. Format data is saved in a standard 2200 data file, named by the user.

When using DAVFU sequence, the following control codes are effective:

HEX(OB) - Vertical Tab (as specified in channel two)

HEX(OC) - Top of Form (as specified in channel one)

HEX(1FOX) - Vertical Tab (as specified in Channel X)

Note: Programs using DAVFU control sequences can load a previously defined sequence by executing the following statements in the application program:

```
DIM T$(128)2
```

```
DATA LOAD DC OPEN T 'filename' : REM 'filename' = name of the user file
```

```
DATA LOAD DC T$()
```

```
$GIO/xyy, (A000,G$) T$() : REM xyy represents the printer address
```

Press 'RETURN'

RETURN causes the following to be displayed on the screen:

No. of lines per page?
 No. of lines per inch?
 Bottom of form is at line?

Enter 'T' for TAB stops,
 Back space and space to delete them.
 T in Channel 1 is TOP (only 1 allowed).
 T in Channel 1 & 2 (same line) is BOF.

		CHANNEL											
		1	2	3	4	5	6	7	8	9	10	11	12
L	1	+!T!+
I	2	-!.!-
N	3	-!.!-
E	4	-!.!-
	5	-!.!-
	6	-!.!-
	7	+!.!+
	8	-!.!-
	9	-!.!-
	10	-!.!-
	11	-!.!-
	12	-!.!-
	13	+!.!+
	14	-!.!+

To move cursor use:
 S.F.'4 - LAST LINE
 S.F.'5 - NEXT LINE
 S.F.'6 - PREVIOUS LINE
 S.F.'7 - FIRST LINE
 S.F.'12 - NEXT CHANNEL
 S.F.'13 - PREVIOUS CHANNEL
 S.F.'20 - DONE EDITING
 FN - RESTART

After the input has been specified (# line, bottom of form), the format can be edited by setting the desired tab stops (or deleting unwanted ones). Note: Tab stops are not allowed in Channel 1 or Line 1--these are reserved for top and bottom of form. Be certain that the printer is set to correspond with the number of lines per inch specified in the format definition.

Once defined, the format can be tested by specifying the number of the channel to be tested. The program skips to, and prints a line of text for, each tab stop on the specified channel. When the test is satisfactory, the format may be saved on the specified channel. When the file already exists, it will be overridden.