

# PRODUCT SERVICE NOTICE

DATE : 1/14/80

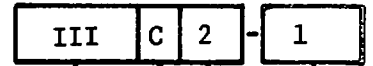

CLASSIFICATION PERIPHERALS

CATEGORY PRINTERS PLOTTERS

PRODUCT/APPL. WANG MATRIX MODEL 77

SEQUENCE # 1

TITLE:

PCB #210-7131, ECN's #11307 and #11497, E REV 2  
for 2261V and 2261W Matrix Printers

**A. REASON FOR CHANGE:**

To enable the use of Texas Instrument PROMs in Character Font locations L1, L4, L6 and L8.

**B. CORRECTION/SOLUTION:**

Add gating to delay WR signal.

**C. PREREQUISITES:**

The 7131 PCB must be at E REV 1, ECN 7165 installed. ECN 7165 is under review, pending corrective action. Boards at artwork level 3 and above have E REV 1 incorporated (Pin 7<sub>2</sub> is first isolated from +5V and then jumpered to L32-1).

**D. TIME REQUIRED:**

$\frac{1}{2}$  hour

**E. PARTS REQUIRED:**

#24-gauge insulated wire, WLI #600-9012



LABORATORIES, INC.

ONE INDUSTRIAL AVENUE, LOWELL, MASSACHUSETTS 01881. TEL. (617) 459-5000, TWX 710 343-6769, TELEX 94-7421

Printed in U.S.A.  
13-5852 12-79

F. PROCEDURE:

1. Cut the etch at the base of L37 pin 6.
2. Add a wire from L37 pin 6 to L31 pin 1.
3. Add a wire from L38 pin 3 to L31 pin 2.
4. Add a wire from L31 pin 3 to L31 pin 4.
5. Add a wire from L31 pin 4 to L31 pin 5.
6. Add a wire from L31 pin 6 to pin 15 of connector 3.
7. Increment the E-REV to 2.
8. Update the 7131 schematics to reflect this change. Refer to Figure 1.

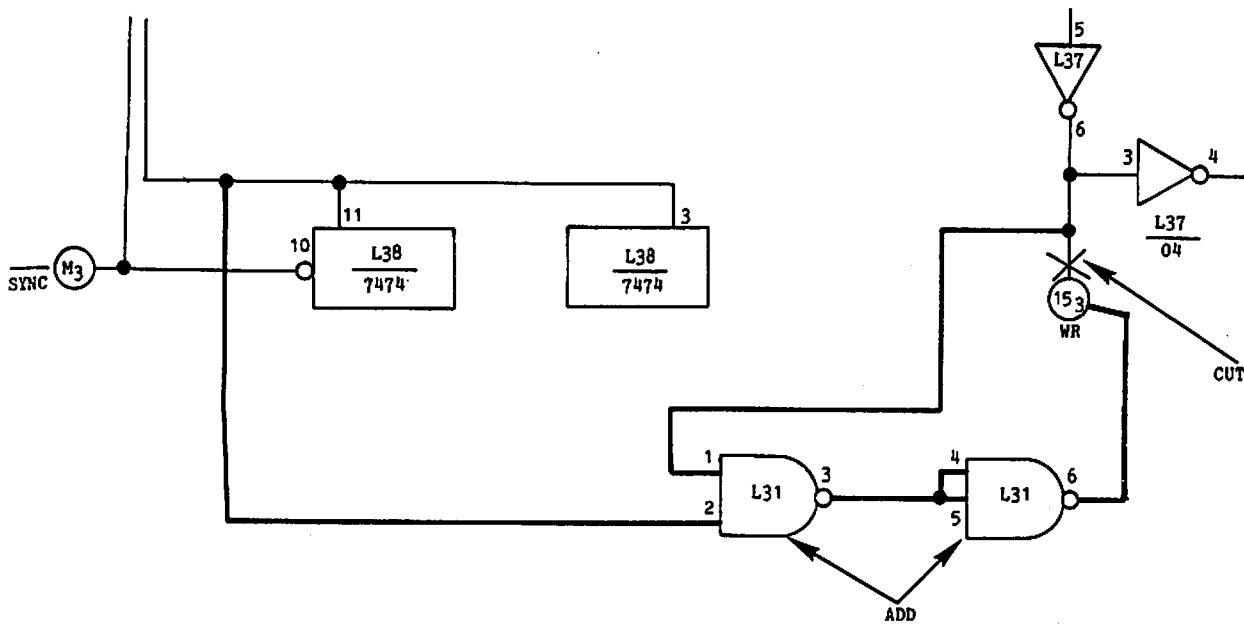

# PRODUCT SERVICE NOTICE

DATE : February 4, 1980

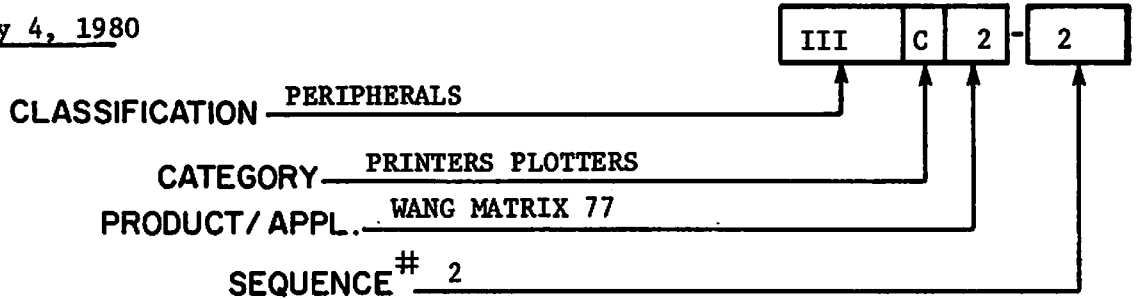

TITLE:

PCB #210-7232\*; ECN #13298; E-REV 4

PCB #210-7232-1\*; ECN #13298; E-REV 1

\* Optical Signal, Paper Feed, and Motor Control PCB's for 2261V

A. REASON FOR CHANGE

Intensity adjustments to the LEDs in the photocoupler amplifiers on 7232/7232-1 boards are too sensitive with the 100-Kohm potentiometers (pots) presently used. Original specifications call for the use of 100-ohm pots in the LED-intensity adjustment circuits.

B. CORRECTION/SOLUTION

Replace the 100-Kohm pots at R49 and R80 with 100-ohm pots.

C. PREREQUISITES

None

D. TIME REQUIRED

0.5 Hours.



**E. PARTS REQUIRED**

Two 100-ohm pots (WLI #336-1023).

**F. PROCEDURE**

1. Replace 100-Kohm pots at locations R49 and R80 with 100-ohm pots. (See Figure.)
2. Perform adjustments described in Section 5.2.2, Paragraph 2 (Window Signal Duty Cycle), of the Model 77 Quad Head Maintenance Manual (03-0061, III.C.2). This procedure was written for the 210-7132 board; however, except for changes in component callouts, it applies to the 7232/7232-1 boards as well. In the maintenance manual, R46 is the 12-pitch LED adjustment pot and R24 is the 10-pitch LED adjustment pot. In the 7232/7232-1 schematics, these pots are labeled R80 and R49 respectively.
3. Increment the E-Rev. sticker on the 7232 board to level 4. Increment the E-Rev. sticker on the 7232-1 board to level 1.

Replace 100K Ohm POTs  
At These Locations (R49, R80)  
With 100 Ohm POTs

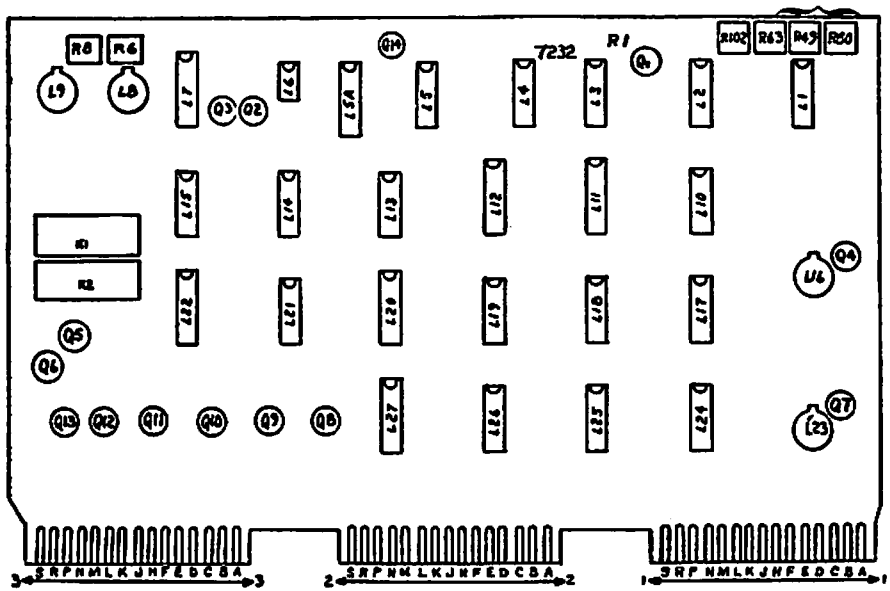

7232/7232-1 COMPONENT LAYOUT

# PRODUCT SERVICE NOTICE

DATE: FEBRUARY 27, 1980

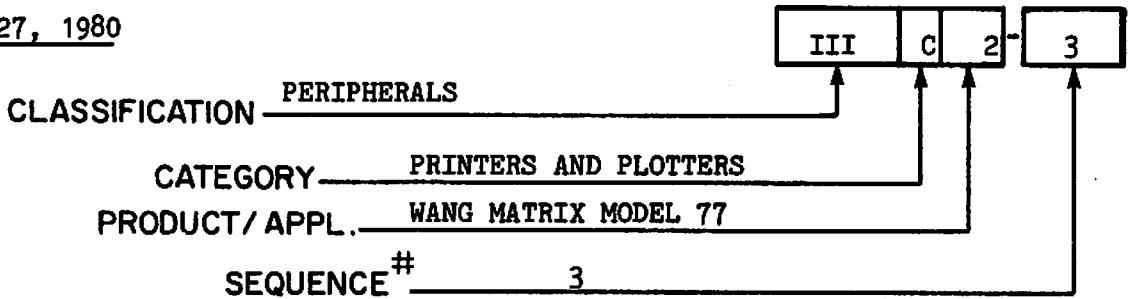

TITLE:

PCB #210-7232, ECN's, E REV 1 thru E REV 3  
**1** 8795, **2** 8854, **3** 12687

The ECN's presented in this PSN apply to the 210-7132 PCB for operation in the 2261W and the 2261V model printers. The prerequisite for installation of each ECN is that all previous ECN's are incorporated. For clarity and ease of installation, each ECN is documented independently. Refer to the figures, which depict actual component locations and wiring changes as well as updated schematic representations.



LABORATORIES, INC.

ONE INDUSTRIAL AVENUE, LOWELL, MASSACHUSETTS 01851, TEL. (617) 459-5000, TWX 710 343-6769, TELEX 94-7421

Printed in U.S.A.  
13-5852 12-79

III.C.2-3

210-7232 PC, ECN #8795, E1

A. REASON FOR CHANGE:

To conform to Customer Engineering time-meter board.

B. CORRECTION/SOLUTION:

Remove the pull-up resistor and ensure that the Time Meter input receives the correct logic level.

C. PREREQUISITES:

None.

D. TIME REQUIRED:

15 minutes.

E. PARTS REQUIRED:

#24-gauge insulated wire, WLI #600-9012.

F. PROCEDURE:

1. Remove R115, located above and to the left of Q9.
2. Remove the jumper from between L5-5 and L5-6.
3. Install a jumper from L14-5 to L5-5.

210-7232 PC, ECN #8854, E2

A. REASON FOR CHANGE:

To eliminate top and bottom of form problems.

B. CORRECTION/SOLUTION:

Add circuitry to stabilize the Photosensor outputs.

C. PREREQUISITES:

The 7232 board must be at E REV 1, ECN #8795 installed.

D. TIME REQUIRED:

1 Hour.

E. PARTS REQUIRED:

Eight 4.7K resistors, WL #330-3047

Four D035 diodes, WL #380-1001-4B

F. PROCEDURE:

The following procedure applies to four similar circuits, each circuit associated with one of the following transistors: Q8, Q9, Q10 or Q11. The procedure for Q8 is found below. Refer to the Figures.

1. Remove the 22K resistor located below Q8 and replace it with a 4.7K resistor (WL #330-3047).
2. Remove the 47K resistor located below Q8 and replace it with a 4.7K resistor.
3. Connect a diode (WL #380-1001-4B), between pin S<sub>2</sub> an Q8's emitter, with the anode connected to Q8, as shown in the figure.
4. Repeat steps 1, 2 and 3 for the identical circuits associated with Q9, Q10 and Q11.

III.C.2-3

210-7232 PC, ECN #12687, E3

A. REASON FOR CHANGE:

To eliminate intermittent top-of-form problems

B. CORRECTION/SOLUTION:

Install noise-suppression circuitry

C. PREREQUISITES:

PCB 210-7232 must be at E REV 2, ECN's 8795 & 8854 installed

D. TIME REQUIRED:

30 Minutes

E. PARTS REQUIRED:

One .01-uF, 25V capacitor, WL #300-1903

Two 4.7-kohm,  $\frac{1}{4}$ W resistor, WL #330-3047-4B

#24-gauge insulated wire, WL #600-9012

F. PROCEDURE:

Refer to the figures.

1. On the non-component side of board, cut the etch between L21 pin 4 and L22 pin 12.
2. On the component side of board, perform the following:
  - a. Jumper L21 pin 4 to L26 pin 11.
  - b. Jumper L26 pin 9 to L26 pin 10.
  - c. Jumper L26 pin 8 to L22 pin 12.
  - d. Add a 4.7-kohm resistor between pin 10 and pin 14 of L26.
  - e. Add a 4.7-kohm resistor between pin 8 and pin 14 of L26.
  - f. Add a .01-uF capacitor between pin 7 and pin 9 of L26.
3. Increment the E REV sticker to 3.
4. Update the schematic to reflect this change. Refer to Schematic.



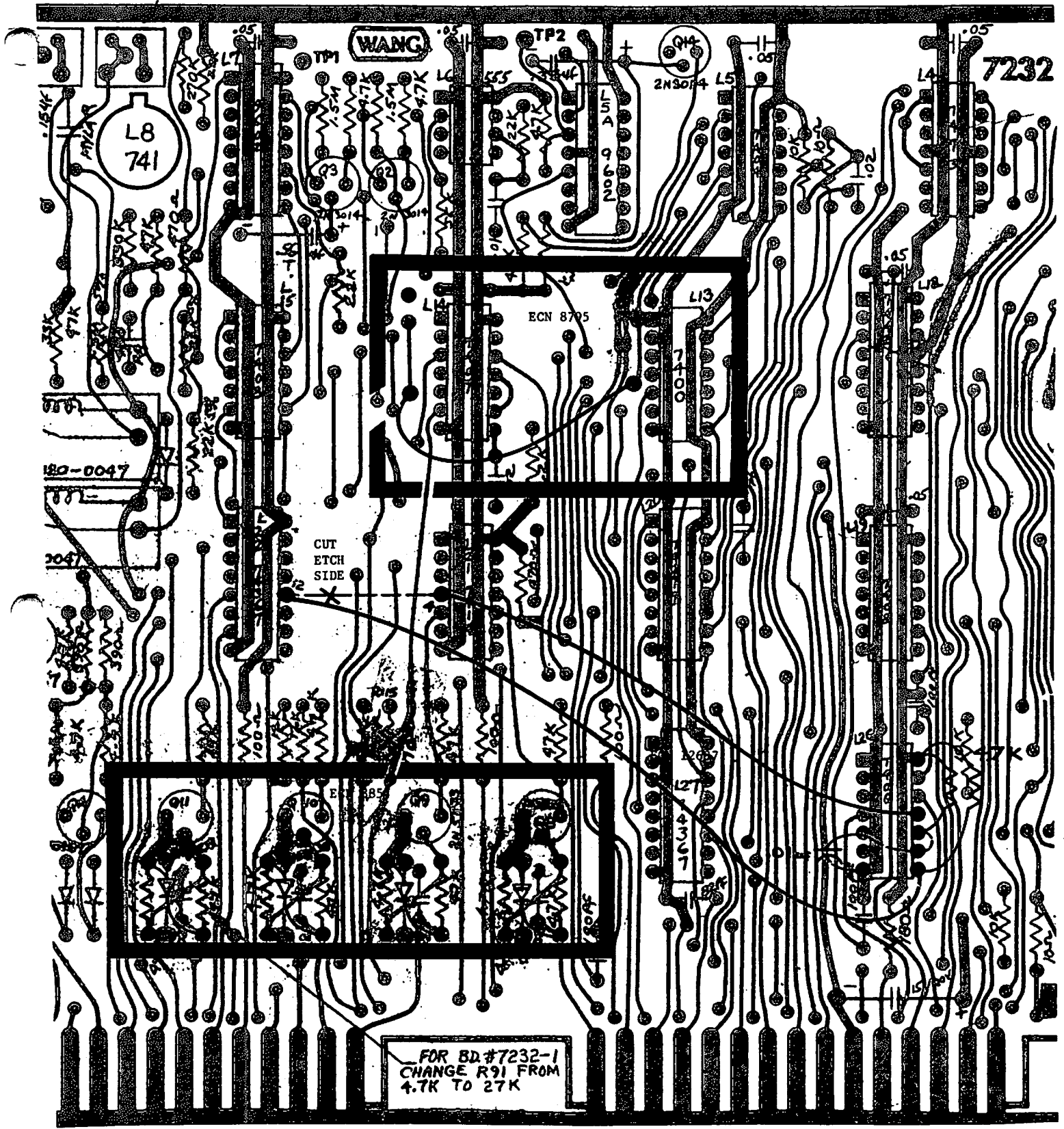

FIGURE 1 210-7232 PCB, COMPONENT SIDE

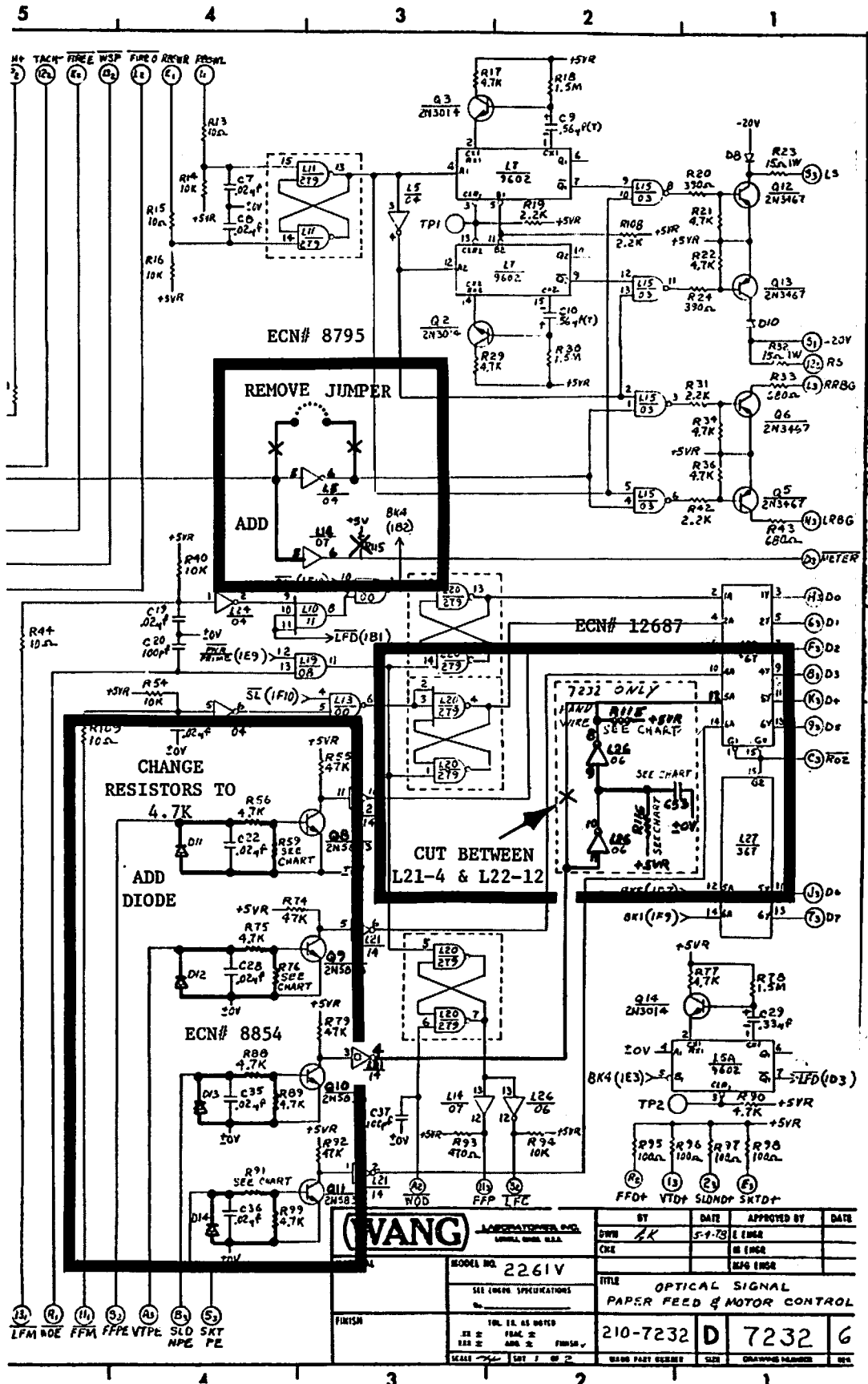
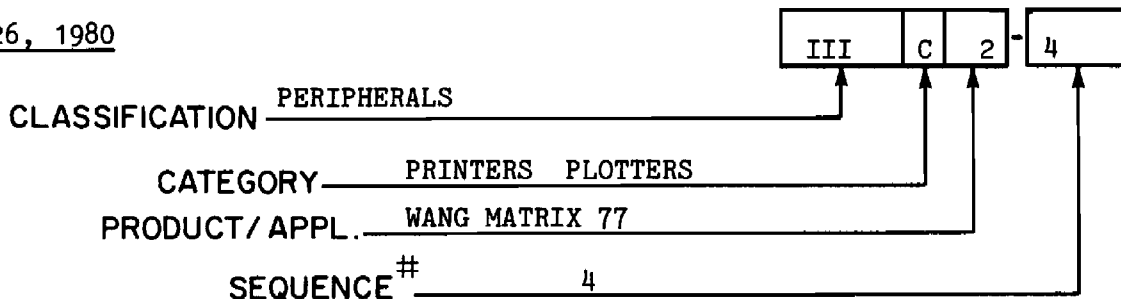

FIGURE 2 210-7232 PCB, UPDATED SCHEMATIC

# PRODUCT SERVICE NOTICE

DATE : FEBRUARY 26, 1980



TITLE:

210-7136 PCB, ECN's E REV 1 THRU E REV 4  
[1] 7181, [2] 7712, [3] 9424, [4] 10883

The ECN's presented in this PSN apply to the 210-7136 PCB for operation in the 2261W and the 2261V model printers. The prerequisite for installation of each ECN is that all previous ECN's are incorporated. For clarity and ease of installation, each ECN is documented independently. Refer to the figures, which depict actual component locations and wiring changes as well as updated schematic representations. Figures 1 and 2 show the physical locations of the component changes, and Figure 3 is the schematic update after all four of the ECN's have been incorporated.



III.C.2-4

210-7236 PC, ECN #7181, E1

A. REASON FOR CHANGE:

Design improvement for better regulation.

B. CORRECTION/SOLUTION:

Modify the +5 volt regulator circuit to improve current foldback.

C. PREREQUISITES:

None

D. TIME REQUIRED:

Less than  $\frac{1}{2}$  Hour

E. PARTS REQUIRED:

One .075 ohm Resistor, WL #334-0035.

One 5.6K ohm Resistor, WL #330-3056.

F. PROCEDURE:

1. Replace R66 (3.3K ohm) with the 5.6K ohm resistor.
2. Add the .075 ohm resistor between 13<sub>1</sub> (+5VR) and the emitter of Q31 (2N3014). This resistance was previously attained by installing two 0.15 ohm resistors in parallel.
3. Increment the E REV from 0 to 1.

210-7236 PC, ECN #7712, E2

A. REASON FOR CHANGE:

To eliminate solenoid misfiring when the printer power is turned off.

B. CORRECTION/SOLUTION:

Add a bleeder resistor to the +12 VRSW supply.

C. PREREQUISITES:

The 7136 board must be at E REV 1, ECN 7181 installed.

D. TIME REQUIRED:

Less than  $\frac{1}{2}$  Hour

E. PARTS REQUIRED:

One 470 ohm, 1 watt Resistor, WL #332-2047

F. PROCEDURE:

1. Insert the 470 ohm resistor between L1 pin 5 and the +12 volt run at the emitter of Q1.
2. Increment the E REV from 1 to 2.

III.C.2-4

210-7236 PC, ECN #9424, E3

A. REASON FOR CHANGE:

The +12 VR and the -12 VR switching control is too critical.

B. CORRECTION/SOLUTION:

Modify the +12 VR and the -12 VR switching circuits to desensitize the cutoff that occurs during variations in the +5 VR, particularly while performing the +5 VR adjustment.

C. PREREQUISITES:

The 7136 board must be at E REV 2, ECN 7712 installed.

D. TIME REQUIRED:

Approx. 1 Hour

E. PARTS REQUIRED:

Two 1N748 diodes WL #380-2039

F. PROCEDURE:

Replace two 1N749 diodes with 1N748's as follows:

1. Remove D20, located above Q22, and, observing the same polarity, replace it with a 1N748 diode.
2. Remove D16, located directly above Q29, and, observing the same polarity, replace it with a 1N748 diode.
3. Increment the E REV from 2 to 3.

210-7236 PC, ECN #10883, E4

A. REASON FOR CHANGE:

To improve the -5V regulator circuit. The existing component tolerances cause high failure rates.

B. CORRECTION/SOLUTION:

To change the tolerances of the transistor regulator and the associated -5V regulator circuit components.

C. PREREQUISITES:

The 7136 board must be at E REV level 3, ECN's #7181, #7712 and #9424 installed.

D. TIME REQUIRED:

45 minutes

E. PARTS REQUIRED:

Two 1-uF ceramic capacitors, WL #300-1931  
One transistor, type 79M05, WL #374-0012  
#24-gauge solid wire, WL #600-9012

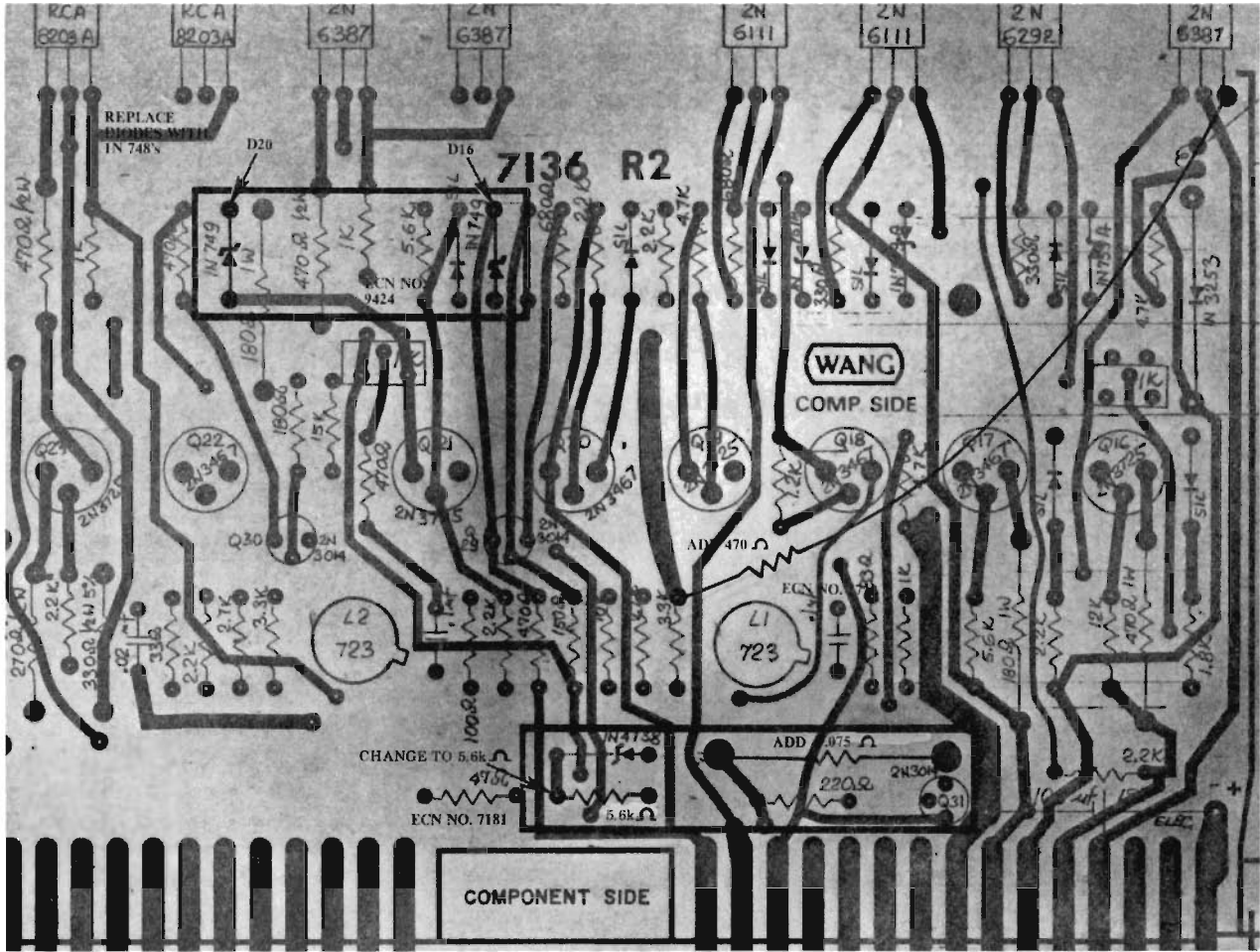

FIGURE 1 ECN's #7181, #7712 and #9424

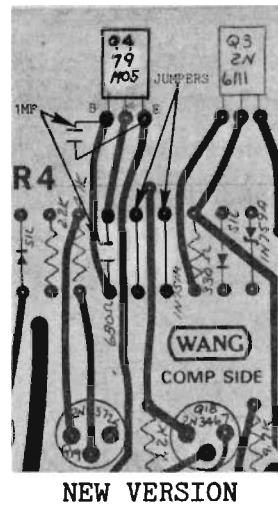
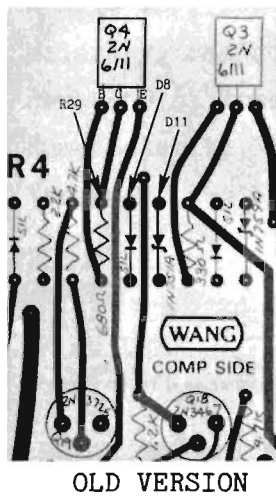

FIGURE 2 ECN #10883



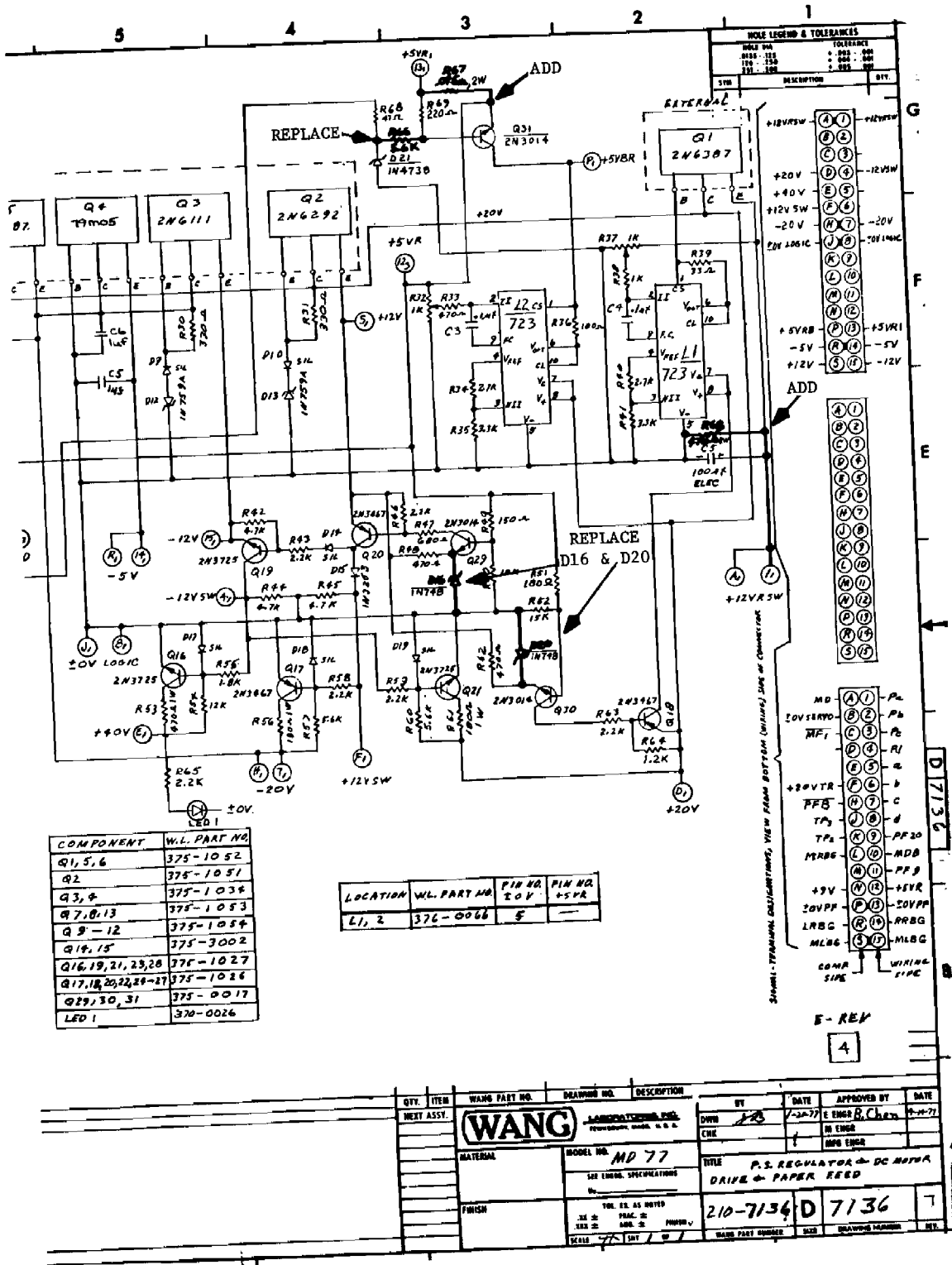
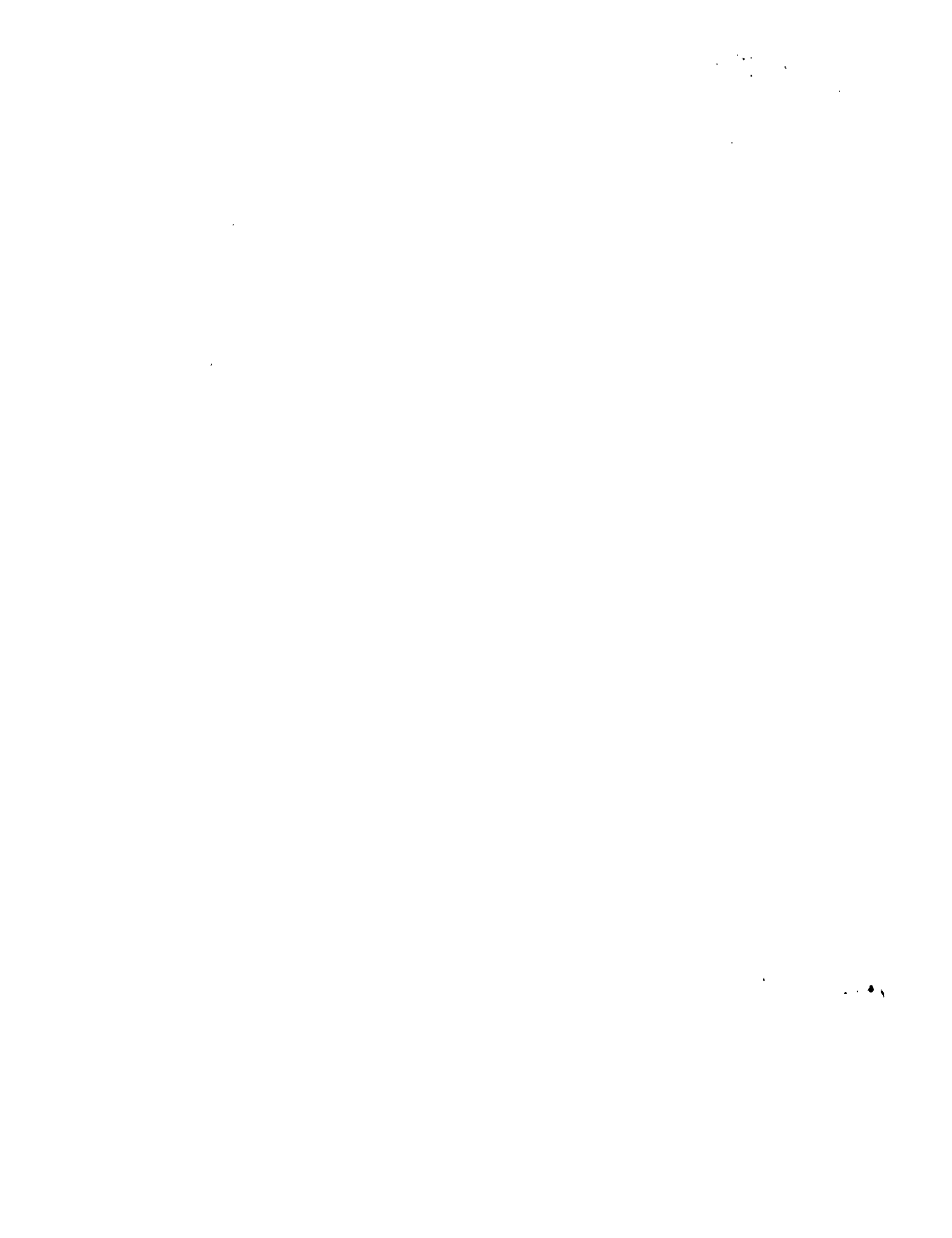

FIGURE 3 UPDATED SCHEMATIC, 210-7236 PCB



# Service Newsletter

NO. 57

AUGUST 9, 1976

## PERIPHERALS #16 MODEL 2261 RIBBON GUIDE

A new ribbon has been designed that supercedes the ribbon guide described in ISN #100. The new ribbon guide is designed to prevent paper streaking and to prevent the ribbon from jumping out of position. This new ribbon guide is available in limited quantity, in the Area offices. If additional ribbon guides are required they may be ordered from William Dorazio, Home Office by submitting request for a *MODEL 2261 RIBBON GUIDE* and the name of the customer where the ribbon guide(s) will be installed.

To install the new guide on the right carriage (see illustration on back):

1. Remove old ribbon guide (if installed).
2. Remove two ribbon rollers.
3. Remove two ribbon roller posts.
4. Align new ribbon guide over roller post holes.
5. Reassemble in reverse order (step 4 to step 2).

In some cases, it may also be necessary to install a ribbon guide on the left carriage. To do so, remove the ribbon guide post from the ribbon guide plate and reassemble with the ribbon guide post on the opposite side of the guide plate, creating a left hand ribbon guide.

**WANG**

LABORATORIES, INC.

8,36 NORTH STREET, NEWSBURY MASSACHUSETTS 01876 TEL (617) 851 4111, TWX 710 343 6769, TELEX 94 7421

Printed in U.S.A.  
13-266

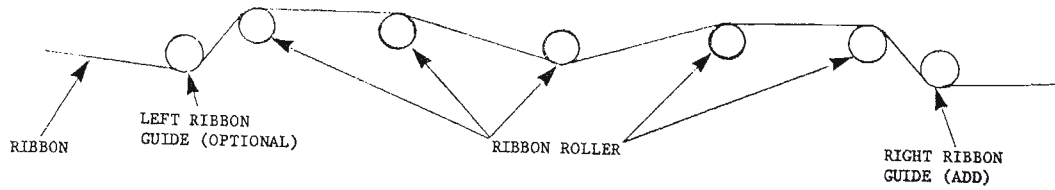
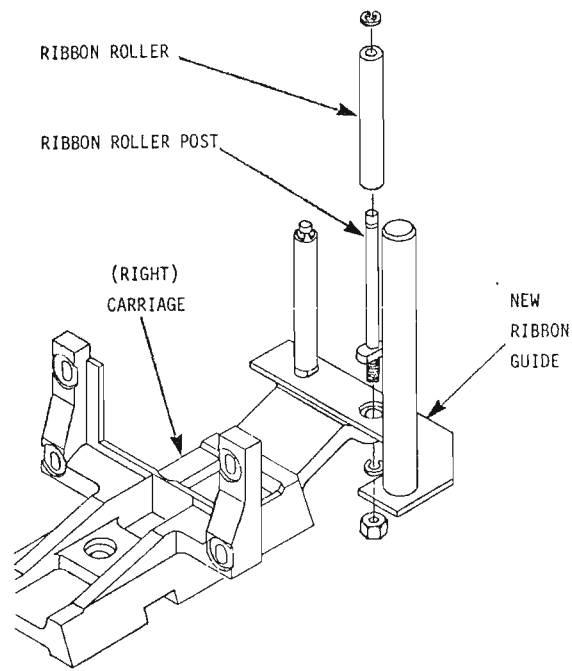

April 5, 1978

PERIPHERALS #29  
MODEL 77 (2261W) MATRIX PRINTER  
STATIC CAUSING DESELECTING

Some Model 77 (2261W) Matrix Printers have experienced deselecting problems caused by static buildup. In many cases, the printer was locked in BUSY even when the select switch was on. This can be caused by static buildup anywhere on the chassis.

In some printers, the ground straps, lugs and screws have a marginal or intermittent contact with the unit ground. This poor ground contact is often traced to paint getting into screw holes and over spade lugs, or simply, loose grounding hardware.

To prevent or correct this problem, remove the ground straps and scrape the paint until bare metal contact surfaces are obtained; then reinstall the ground straps. Check the four main ground straps, at the following locations:

1. From the rear door to the main cabinet.
2. From the electrical chassis to the main cabinet.
3. From the front door to the main cabinet.
4. From the printer base casting to the main cabinet (at the right side of the printer mechanism).

## PERIPHERALS #33

### MODEL 2261W INCORRECT PHOTOCCELL PART NUMBER

In the "Model 77 Quad Head Printer Manual, Addendum A - March 19, 78", the margin sensor photocell (page H-24 #38) is incorrectly called out as part #279-5077-31. The correct part number is 375-2107.

The 279-5077-31 has a mask on it and is used for timing fence sensors only.

	<b>NO.</b> 157	<b>DATE:</b> 12/23/77
	<b>CATEGORY</b> PERIPHERALS #14	
	<b>SUBJECT</b> MODEL 77 (2261W) MATRIX PRINTER SOLENOID WIRE BREAKAGE	

Some Model 77 (2261W) Matrix Printers have experienced solenoid wire breakage problems. The most common cause of these print head failures is incorrect striker plate alignment. If the print head bearing to striker plate clearance is less than .005" when the head adjustment arm is set to maximum penetration (due to incorrect alignment), the solenoid wires may break during firing.

By the procedures that follow, check the clearance from the print head bearings to striker plate. If the clearance is less than .005" when the print heads are set to maximum penetration (with ribbon and paper removed), adjust the striker plate to obtain the correct gap of .005" + .001"-.000".

The following procedures are for checking and performing striker plate alignment. The procedures given below are essentially the same as those given in the Maintenance Manual for the Model 77 Quad Head Matrix Printer; the main difference is the clearance specification for the striker plate to print head bearing. In the Maintenance Manual, the gap specified is .006"; in this service notice the gap specified is .005". The .005" gap setting should be used only on printers which are experiencing solenoid wire breakage; on other printers, the gap should not be changed.

Other possible causes of print solenoid failure are listed at the end of this service notice.

A) STRIKER PLATE ADJUSTMENT CHECK

1. Turn the main power off and remove the steel fan and head cover assembly (print head shield).



LABORATORIES, INC.

1 INDUSTRIAL AVENUE, LOWELL, MASSACHUSETTS 01851. TEL. (617) 851-4111. TWX 710 343-6769. TELEX 94-7421

2. Remove the ribbon and the paper.
3. Set the head adjustment arm to the maximum penetration position (heads all the way forward).

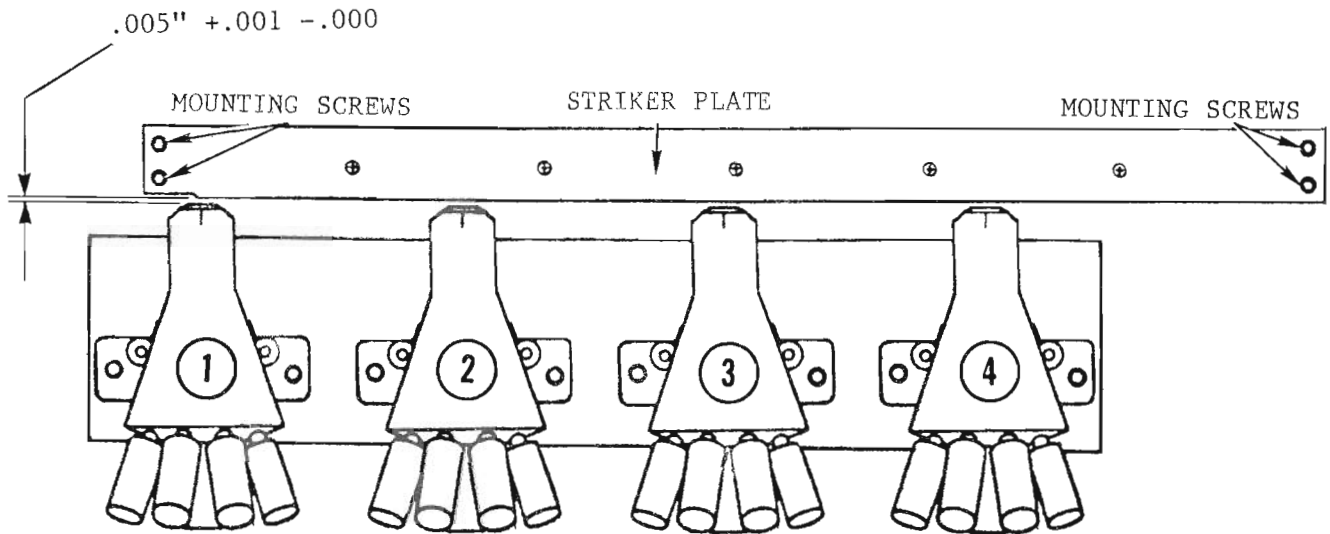

FIGURE 1

4. Move the carriage assembly to the left margin.
5. Using a feeler gauge, measure the gap from print head bearing #1 (leftmost head) to the striker plate. See Figure 1. This gap should be  $.005'' + .001'' - .000''$ . Note the exact measurement and continue with the next step.
6. Move the carriage assembly to the right margin. Again measure the gap from print head bearing #1 to the striker plate. The second measurement should be within  $.001''$  of the first, but never less than  $.005''$ .
7. Repeat this procedure for each of the remaining print heads. For each individual print head, the difference in gaps at the left and right margins should not exceed  $.001''$ , nor should any head be closer than  $.005''$  to the striker plate. If any heads vary more than  $.001''$ , proceed with a striker bar adjustment or print head adjustment as required.



NOTE:

Because the striker plate alignment and print head alignment are interdependent, it is important to perform only one of these adjustments at a time. If the mounting screws for both the striker plate and print heads were to be loosened at the same time, there would be no reference point to guide these adjustments.

B) STRIKER PLATE ADJUSTMENT

1. Loosen the two Allen head screws at each end of the striker plate.
2. Move the striker plate forward or back (the rear paper guide will also move) until it is parallel to the main carriage. Tighten the Allen head lock screws and perform the striker plate adjustment check.
3. Repeat steps 1 and 2 until the gap from the striker plate to the print head bearings changes less than .001" as each print head moves from margin to margin.

C) PRINT HEAD ADJUSTMENTS

1. If it is necessary to adjust the individual heads for a gap of .005" minimum or .006" maximum, loosen the four Allen head screws on the head mounting bracket. Turn the eccentric (1/4 inch nut, front-left on bracket) clockwise or counterclockwise until the correct gap is obtained.

D) OTHER CAUSES OF SOLENOID WIRE BREAKAGE

1. The firing pulse may be greater than 425 microseconds (7134 PCB, L17 pin 7).

2. The solenoid wires may be projecting more than .002" from the print head bearing (ideal rest position is flush with the bearing).
3. The servo speed may indicate a full cycle of less than 900 microseconds.
4. The 10 or 12 pitch window signal may have a greater than 50% duty cycle. See Figure 5-6 in the Maintenance Manual for the Model 77 Quad Head Matrix Printer (Figure 5-3 in Preliminary Manual).
5. The customer himself may be causing the failures by increasing the penetration of the heads to get better print quality with an old inked ribbon. If this appears to be the case, explain to the customer that this practice is poor economy since it could result in long periods of down time for his printer.

Even if the minimum clearance (.005") from the print head to the striker plate is maintained, the customer may still cause broken solenoid wires by using thicker than normal single-ply and multi-ply paper and carbons and, at the same time, increasing the head penetration beyond a normal setting.

The customer should be advised not to exceed, by more than one detent position, the head penetration setting needed to give good print quality with a new ribbon. For example, with a specific form of 4-ply paper and 3-ply carbon, good print quality can be obtained at a setting of 3 on the head penetration indicator immediately after a new ribbon is installed. The customer should not increase this head penetration setting by more than one detent position on the detent bracket. If the customer does go beyond one detent (approximately .002"), he can expect failures in the solenoid wires.

	<b>NO.</b> 167	<b>DATE:</b> 4/4/78
	<b>CATEGORY</b> Peripherals #18	
	<b>SUBJECT</b> Model 77 (2261W) Matrix Printer Electrical Shorts - - 7132 PCB	

Some Model 77 (2261W) Matrix printers have experienced failures in the 7132 OPTICAL SIGNAL, PAPER FEED & MOTOR CONTROL PCB. The symptom of this problem is excessive carriage speed.

The tachometer circuit on this board has a mylar capacitor (C7) across the signals TACH+ and TACH-. When this capacitor has been punctured and shorted out by the sharp pins of adjacent boards, the two tachometer signals are then shorted together, leaving the tachometer inoperative. The carriage servo motor is left with no tachometer to govern its speed, and the carriage moves at more than twice its normal rate.

**CAUTION:**

Do not operate a failing printer for any sustained period; it could damage the printer mechanism.

Capacitor C7 is the yellow, 100VDC, .15 Microfarad mylar capacitor near the side of the board (See Figure 1). If these symptoms occur, replace the capacitor (WLI #300-2215).

The capacitor is damaged when the board is shipped or handled improperly. To prevent this problem, do not stack any boards on the component side of the 7132 board. Always isolate the 7132 board by wrapping it in Styrofoam packing material or by keeping it separate in its own shipping envelope.

Figure 1 shows the location of capacitor C7 on the 7132 board. On artwork Rev 2 boards, the capacitor is closer to the edge of the board, near potentiometers R5 and R7.

CAPACITOR (C7)

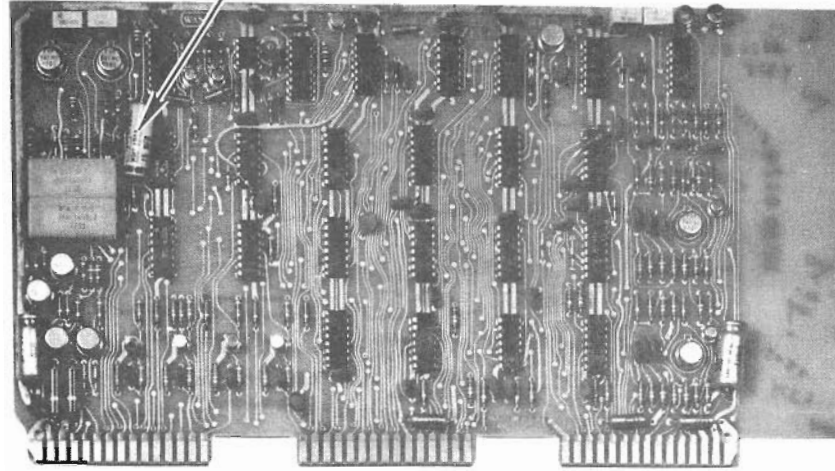

FIGURE 1 7132 PCB OPTICAL SIGNAL, PAPER FEED & MOTOR CONTROL

**WANG**

LABORATORIES, INC.

*Buel*

M-E-M-O-R-A-N-D-U-M

TO: ATOMs, SUBSIDIARY SERVICE MANAGERS & TECH. SPECIALISTS  
FROM: MITCH CORRIGAN  
DATE: JUNE 1, 1978  
SUBJECT: RECAP AND PROGRESS ON 2261W PROBLEMS

-----

1. PRINT HEAD PROBLEMS

As a result of testing performed in Billerica, Engineering and Customer Engineering have come to the conclusion that print head problems are caused as a result of design in two areas of the print head.

- A. At the rear of the bearing, wear occurs on the print wire during impact of a print wire on the striker plate of the printer.
- B. It is believed now that the firing time of the solenoid is actually too long causing impact during drive rather than in free flight. This excessive amount of firing time causes a bend of the print wire directly behind the print bearing.

The high wear point in the rear of the bearing coupled with the excessive firing time causes the break that we are now experiencing in the field. To verify this, tests have been done to verify and attempt to resolve the problem. Different areas covered in the test are listed below:

- A. An Alumina bearing sent to us from WESA that was made in Switzerland by the Monet Corporation has been tested with very impressive results. There have been no broken print wires, yet the bearing itself has broken. This proves that a new bearing or design will effect print wire life.

- B. A jewel material such as that used by Centronics was tested which is very similar to the Alumina bearing. No print wire breakage resulted. However, the jewel did not stay in the head. This of course, could have been a result of inexperience in mounting that material.
- C. A special Wang bearing was made with metal in the front and a plastic bonded to it in the back. The plastic would do two things for us even though it will not last long.
1. By placing the softer material (plastic) on the rear of the bearing it would decrease the wear experienced by the hard material.
  2. It supports the print wire disallowing the bend that occurs during an excessive firing time.

During testing performed on these heads no solenoid failure was encountered, however binding did occur causing deteriorating print quality.

- D. The wire breakage was decreased when firing time on the solenoid was reduced from 425 microseconds to 375 microseconds. Even though a regular bearing was used we have found that breakage is greatly reduced at this setting. Tests performed here also show that even though the firing time was reduced, print quality was not. This was based on the papers we used. We will call in a paper vendor and have them do print quality tests for us with different weights and bonds to see if it has a significant effect on print quality.



2. SERVO GEAR BREAKAGE

The plastic gear now existing on the servo of the 21W and 61W is being replaced with a metal gear. It should occur at any time and we will make this gear available to field personnel with some type of means to replace it in the office or the field if necessary.

3. RIBBON CONSISTENCY AND COLOR PROBLEMS

This problem was caused by tape which held the ribbon to the spool that eventually discolored the ink in the ribbon. The idea of going to another tape has already been looked into, however, rather than to take chances on another adhesive, the vendor and Wang has decided that staples would be used to hold the ribbon to the spool rather than tape.

4. RIBBON DEFORMATION CAUSED BY THE RIBBON REVOLVING EYELET

There are two possibilities to this solution:

- A. The spool can be modified so that the existing eyelet would fall into a groove that would be molded into the spool.
- B. The eyelet can be reduced by size. The vendor and Wang are presently pursuing this idea.

5. RIBBON HEIGHT PROBLEMS

Ribbon height problems that cause the ribbon to be kicked from its normal position behind the head.

- A. An ECN has been generated to increase the size of the adjusting slots of the right hand guide bracket (451-4511) so that the ribbon can be adjusted to the proper location.
- B. Parts will be expedited for the field so that we can modify any units that we see fit.
- C. Production units are being modified that are In-House so units going to the field will not have this problem.

WANG

LARGE AREA SYSTEM

6. PRINTING BECOMES LIGHTER DURING / RIBBON CHANGE

We have not been able to duplicate this problem yet.

7. MANY ETCHES BURN OUT ON THE MOTHER BOARD AND LOGIC BOARDS ON THE 2261W

After phoning our Area offices, we have found out that the most common etches were the plus and minus 20 volt and the etches between the solenoid drivers and the solenoids. Two steps have been taken to resolve this problem:

- A. The etches of plus and minus 20 volts will be replaced with 16 gauge wire on the mother board.
- B. Fuses will be added to the finger boards of the print heads so that each solenoid will be fused separately. This will protect the solenoid and the etches in that circuit.

8. D1 AND D2 OF THE 7156 BURN UP

In investigating this it was found that this occurs during a power up. There is no hardware probe for that particular circuit causing the stepper motor in the line feed circuit to remain in a high current state until some function in that circuit is performed. An ECN has been cut to resolve this problem (ECN 8835).

9. WHEN A SOLENOID DRIVER SHORTS, THE USUAL RESULT IS A BURNED SOLENOID

In discussing and looking into this, we discovered that several problems exist. First, a solenoid is burned by a shorting transistor and; second, the transistor failures were caused by diodes placed in the circuit to protect them. These diodes are run at a temperature higher than they were rated, therefore causing their current capacity to drop.

To resolve these problems the following steps were taken:

- A. Fuses were put on the finger boards on the print heads to protect each solenoid (in production now).



- B. A fan has been mounted directly beneath the driver boards which will be mounted to the door in the rear of the 2261W. This fan will keep the diodes in their proper operating temperature range.

10. HEAD ADJUSTMENT ARM FREQUENTLY LOOSENS UP

The existing locking hardware has been changed to prevent this. An ECN was cut to create a hardware change. An ESNA plastic stop nut WLI #458-0803 will replace the existing locking nut.

11. PAPER STREAKING OCCURS ON MANY PAPERS USED ON THE 2261W

Several problems surround this subject.

- A. Customers are being sold units with the belief that certain papers will work in the printer yet when they receive a printer, they find that the paper they planned on using was out of specification.
- B. At times the paper we recommend streaks.

Both of these problems are being dealt with on a marketing and engineering point of view. There are no definite results yet, but as soon as print head testing ceases, we will pursue this at a faster rate.

12. THE TIMING FENCE AS IT IS PRESENTLY MOUNTED, COLLECTS DUST AND EVENTUALLY CAUSES PRINT QUALITY PROBLEMS

There are two directions being pursued to solve this. (1) a felt wiper is going to be added to the carriage to clean the timing fence as it is in operation; (2) A dust cover is being evaluated to shield this area from the falling paper dust.

13. A PROBLEM EXISTS WITH USING A DELETE FUNCTION ON THE 61W

A line feed should not accompany the delete code. This should be easily solved with a microcode change and is presently being addressed in Engineering.

**WANG**

LABORATORIES, INC.

14. PRINT WIRE RETURN SPRING BREAKAGE ON THE 31W

This problem is believed to be caused by the design of the housing of the 31W solenoid. Some modified units were made on May 19th for testing by Customer Engineering so no results are available yet.

15. THE 31W SPROCKETS ARE NOT IN LINE WITH ONE ANOTHER IN SOME UNITS

This was an assembly problem. It has been resolved by the creation of a new alignment tool for use by Manufacturing. It should not be seen on any more future manufactured machines.

I feel that a significant amount of progress has been made on the 2261W and that it will continue. By the direct input and efforts of our field people, we have been able to simulate and verify these problems. I am sure if the people in the field, Home Office, and Engineering continue to diligently pursue these problems, the 2261W will soon become the product it was designed to be.

Regards,

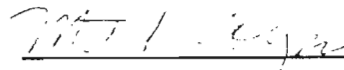
  
\_\_\_\_\_  
MITCH CORRIGAN

MC/mak

MIKE BAKIA

2261W ELECTRICAL ADJUSTMENTS

7136 BOARD

VOLTAGE	TEST POINT	ADJUSTMENT
+5VR <sup>to</sup>	12(3)	R32 MUST HAVE THIS +5VR TO GET
+12VRSW	A(1) & 1(1)	R37 THIS +12VRSW
-5V	R(1) & 14(1)	} BALLPARK VOLTAGES
-12VSW	4(1)	
+20V	D(1)	
+40V	E(1)	
-20V	H(1) & 7(1)	
+5VRB	P(1)	
+5VR1	13(1)	
+12V	S(1)	
-12V	15(1)	
+9V	N(3)	

SERVO SPEED - 7132 PCB PRINT SPACE

FORWARD SPEED ----- 12PITCH SWITCH WS AT L18 PIN 9 ADJUST R7 FOR 900US R7 WILL CHANGE BOTH FORWARD & REV. CYCLES

REVERSE SPEED ----- 12PITCH SWITCH WS AT L18 PIN 9 ADJUST R5 FOR 900US

WINDOW SIGNAL DUTY CYCLE - 7132 PCB

12 PITCH DUTY CYCLE - 12PITCH SWITCH WS AT L18 PIN 9 ADJUST R49 FOR 50% DUTY CYCLE ADJUST R46 CW IF 50% DUTY CYCLE CANNOT BE OBTAINED

SELECT PRINT 215(160) PRINT SPACE

10 PITCH DUTY CYCLE - 10PITCH SWITCH WS AT L18 PIN 9 ADJUST R30 FOR 50% DUTY CYCLE ADJUST R24 CW IF 50% DUTY CYCLE CANNOT BE OBTAINED

SELECT PRINT 215(132) PRINT SPACE

INDEX TO WINDOW DELAY - 7132 PCB PRINT SPACE

6 LINE/INCH SWITCH CHANNEL 1 AT PIN 11(3) OF 7132 PCB CHANNEL 2 AT L24 PIN 8 OF 7132 PCB TRIGGER NEG, CH 1, CHOP TIME BASE 1MS

2V/cm

ADJUST BUMPER SCREWS FOR 5-6MS GAP FROM TRAILING EDGE OF INDEX PULSE (SIGNAL AT PIN 11(3)) TO WINDOW SIGNAL (L24 PIN 8) ADJUST MARGIN PHOTOCOUPLER IF NECESSARY

FIRING TIME - 7134 PCB PRINT SPACE

FT AT L17 PIN 7 ADJUST R2 FOR 425US

WILL NOT WORK UNTIL CLEAR BUTTON DEPRESSED

7035

7035

7035

7035

7136

R37

7132

R49 R30 R24 R46

7134

R2

7131

7137

I/O

I/O

MOTHERBOARD  
POT LOCATIONS

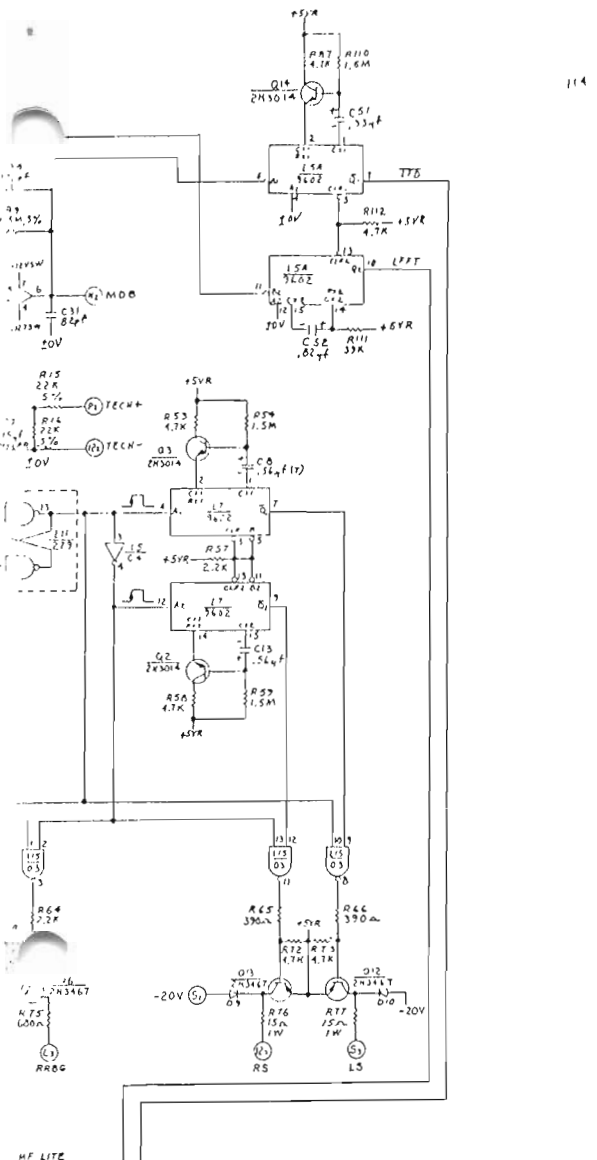

COMPONENT	WE PART NO
R1, 26	330-2010
R2, 11, 10, 12, 21, 34, 34	330-4010
R3, 23, 15, 101, 102, 115	330-1010
R4, 17, 15, 33, 29, 29	330-1010
R5, 1107	330-1010
R6, 106, 115	330-1047
R7	330-1014
R8	330-5027
R9	336-1017
R10	330-5048
R11	330-6016
R12	330-5040
R13, 14, 44, 93, 94	330-4033
R14, 10, 10, 39, 103, 103, 103, 103	330-3033
R15, 16	330-4047
R16, 23, 24, 10, 41, 15, 30	330-4027
R17	330-2015
R18, 16	330-1000
R19, 42	330-5014
R20, 14, 33, 39, 39, 33, 38, 70, 71, 71, 24, 47	330-3047
R21, 9A	330-2022
R22, 49	330-1020
R23, 37, 57, 60, 43, 44	330-3022
R24, 50	330-5010
R25, 82, 84, 97, 102	330-2010
R26, 26	330-5015
R27	330-2033
R28	330-1022
R29, 66	330-2033
R30	330-4056
R31, 75	330-4022
R32, 83, 110, 115	330-2068
R33, 77	330-1015
R34, 55, 110	330-6015
C15, 17, 18, 19	300-1910
C16, 25, 27, 30	300-1100
C17, 33	300-1150
C18	300-2215
C19, 13	300-4010
C20, 10, 11, 12, 20, 22, 24, 25, 26, 28, 29, 30, 42, 1, 53, 24	300-1912
C21, 16, 21	300-1903
C22, 15	300-1900
C23, 32	300-4022
C24	330-3010
D1-12	300-1001
K1, 2	320-0047
C31	300-1082
D1	375-1027
Q1, 3, 4, 7, 14	375-0017
Q2, 6, 12, 13	375-1026
Q3, 9, 10, 11	375-1026
C34	300-1470
C35, 47	300-3011
R36, 92	330-4012
C36, 4	300-1330
R111	330-4033
C52	300-4012
C51	300-4009

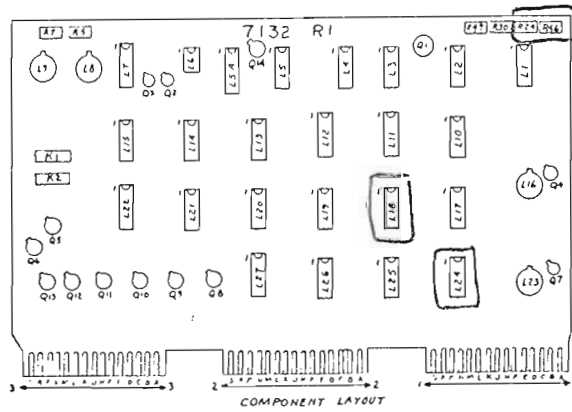
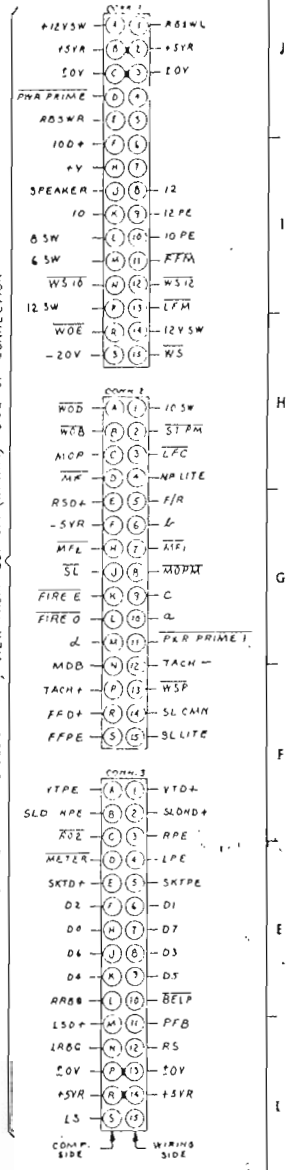

BOTH POTS ALL THE WAY CCW

WE PART NO	QTY	WE PART NO	QTY
16-0081	7	14	14
16-0025	7	14	14
16-0035	7	14	14
16-0005	11	4	4
16-0010	7	14	14
16-0126	1	8	8
16-0104	8	16	16
16-0074	7	14	14
16-0124	7	14	14
16-0165	8	16	16
16-0004	8	14	14
16-0139	7	14	14
16-0176	8	16	16

LOCATION	TYPE	SPARES
L1	740A	3
L3	7406	1
L13	7400	1
L17	9335	2
L24	7406	4
L27	74367	4

**WANG** LABORATORIES INC.

MODEL NO: MD 77

TITLE: OPTICAL SIGNAL PAPER FEED MOTOR CONTROL

NO. 10-23-6010

DATE: 10-23-60

WANG PART NO: 710-7132

QTY: 2

ECN  
NO. PENDING

E-KEY  
O

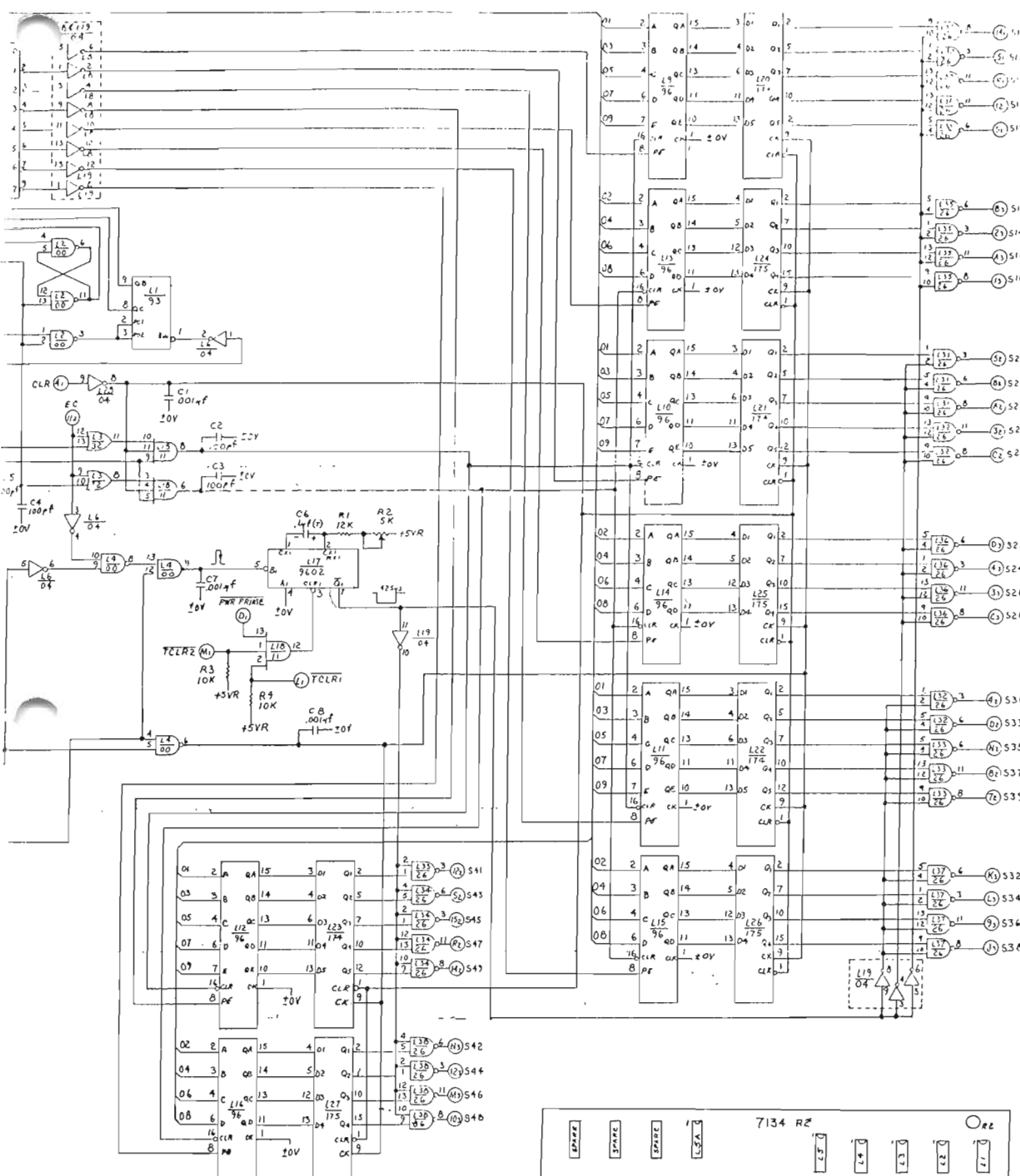

COMPONENT	N.L. PART NO.	QTY.
R1	330-4711	
R2	336-1013	
R3,4	330-4310	
C1,7,8	300-1964	
C2,3,4,5	300-1111	
C6	300-4002	
C9-19	300-1900	
C20,21	300-3011	

LOCATION	N.L. PART NO.	QTY.
L1	376-0011	10
L2,4,5A	376-0022	7
L3	376-0093	7
L5,7	376-0008	8
L6,8,19,25,29	376-0010	7
L9-16	376-0065	5
L17	376-0104	8
L18	376-0194	7
L20-23	376-0098	8
L24-27	376-0117	8
L30-36	376-0067	7
L5B	376-0048	8

LOCATION	TYPE	SPARE
L4	7400	1
L6	7404	3
L5A	7400	2
L3	7437	1
L7	7402	1
L2B	7404	2

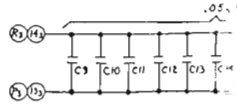
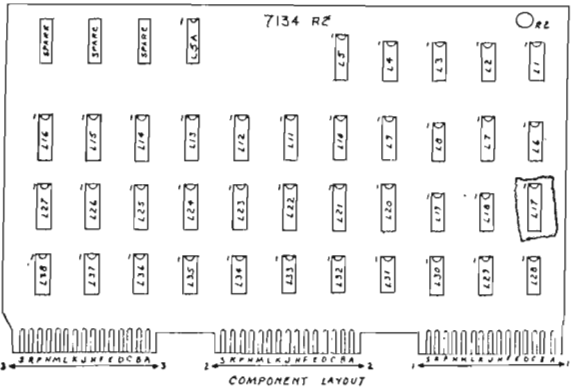

WARRANTY PART NO.	ITEM	QTY.

*Mike Bakia*



MEMORANDUM

TO: ALL CUSTOMER ENGINEERS  
FROM: GENE BARTOS  
SUBJECT: 2261W - ECN #7358  
DATE: NOVEMBER 1, 1977

---

Enclosed is a copy of ECN # 7358 which is supposed to fix a bug in the Power On Prime circuit in the 2261W. This ECN would affect units shipped prior to September 1, 1977.

However, after installing this ECN the clear switch must be keyed after applying power to the printer in order to perform a Line Feed, Top of Form, or Select. Please inform your customers when installing this ECN of this power on procedure.

Regards  
*Gene Bartos*  
Gene Bartos

cc: Dick Nichols  
Keith Jones  
Scott Tagen



GB/pb

WANG

(85) AT'S TOPS INT'L

ECN

*John Zidek*

ECN No. 7358

SHEET 1 OF 2  
DATE 8-25-77  
RFA NO. (REF)

MC KM

ORIGINATOR Bob Chen DEPT 15 EXT 2460 DATE 8/24/77  
MODEL NO. 2261W TITLE

ECN NO. 7358

PART NO.	210-7137	PART NAME		REV. F	T	PC REV. FROM	TO	ELEC. REV. FROM	TO
DWG. NO.	E 7137	(DWG. TITLE)	8080A I/O Interface	-	-	-	-	3	4
ASSY PART NO.		ASSY TITLE		EFFECTED <input type="checkbox"/> NO EFFECT <input type="checkbox"/>					

DESCRIPTION OF CHANGE

Change artwork, loading sketch and schematic per attached print

Change BOM as follows:

WL#	QTY	DESCRIPTION
Change: 376-0002	from 2 to 3	7400N IC

REASON FOR CHANGE

To fix bug in the Power On Prime Circuit

NEW PURCHASE REQ'D  SHOP REWORK REQ'D  VENDOR REWORK REQ'D

CUSTOMER ENGINEERING  
 IMMEDIATE CUST  
 CUST PER NEXT CALL  
 INFORMATION ONLY  
 NONE

ACKNOWLEDGE BY: \_\_\_\_\_ DATE: \_\_\_\_\_

MANDATORY CHANGE  
 DOCUMENTATION CHANGE (PL, BOM, DWG)  
 EASE OF MFG., COST REDUCTION  
 PRODUCT IMPROVEMENT

DISPOSITION	Bonded	FINAL ASSY AREA	SUB ASSY AREA	PARTS		Future MFG.
				IN House	Outside Vendor	
USE AS IS TO PREVIOUS REV.	X					
TO CONFORM		X	X			X
TO CONFORM IF NOT BEYOND OPERATIONS EFFECTED						

FINAL APPROVAL *S.K. Ho*

APPROVED DESIGN ENGRG *Robert Chen*

APPROVED MFG. ENGRG. *D. P. Richer*

WRITTEN BY *Paul H. Richer*



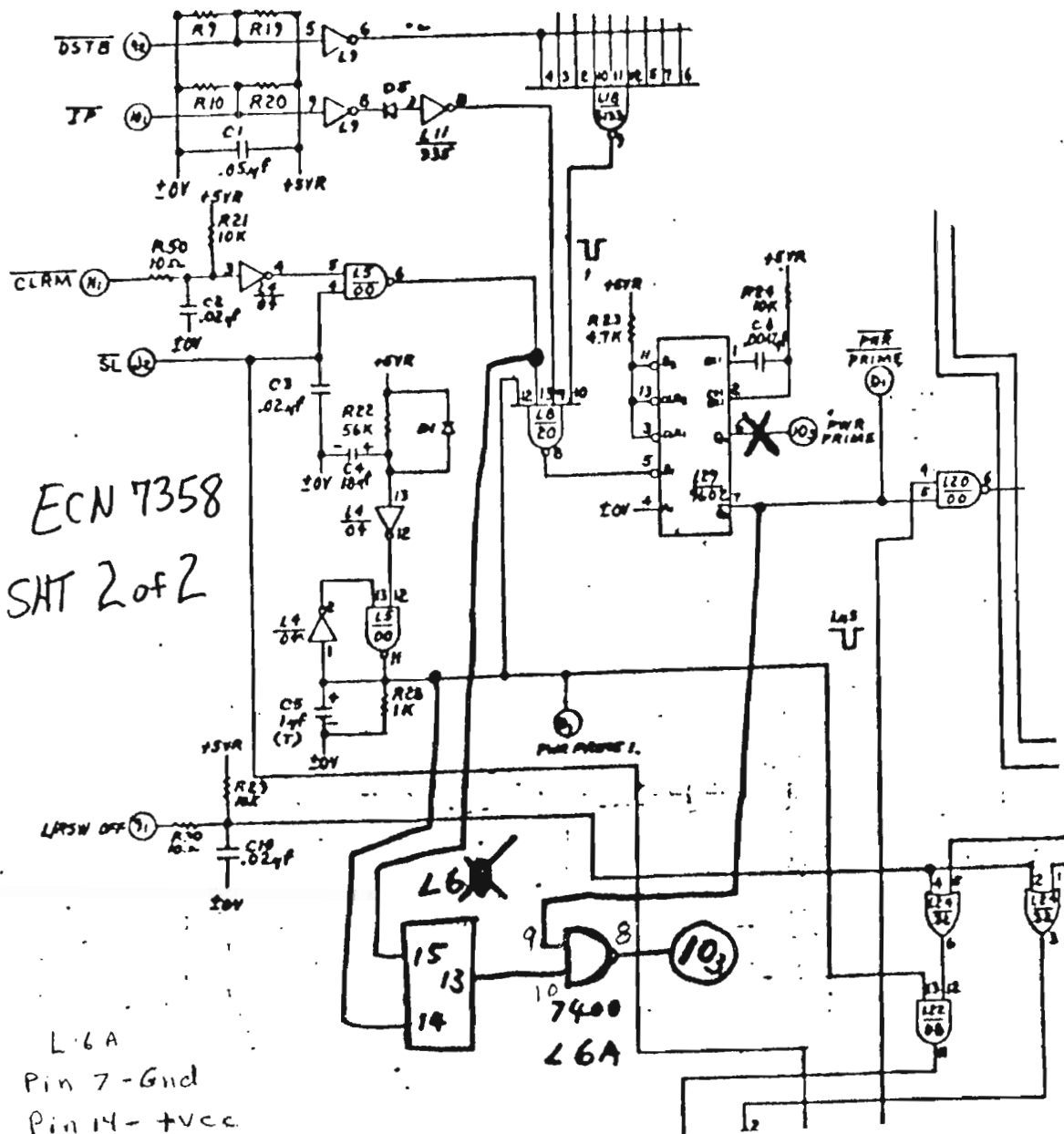
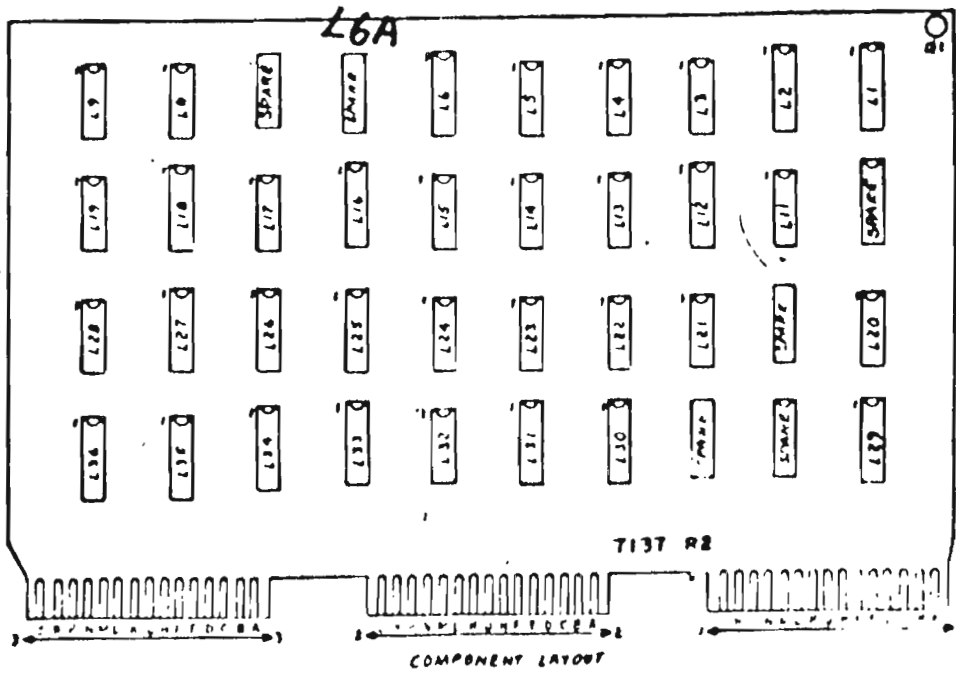

ECN 7358  
SHT 2 of 2

L6A  
Pin 7 - Gnd  
Pin 14 - +Vcc

WANG

(85)

ATS  
TOPS  
INT'L

ECN

*John Fisher*

ECN No. 7358

SHEET 1 OF 2  
DATE 8-25-77  
RFA NO (REF) \_\_\_\_\_

ORIGINATOR Bob Chen DEPT. 15 EXT. 2460 DATE 8/24/77  
MODEL NO. 2261W TITLE \_\_\_\_\_

ECN NO. 7358

PART NO. <u>210-7137</u>	PART NAME (DWG. TITLE) <u>8080A I/O Interface</u>	REV F T	PC REV FROM TO	ELEC. REV FROM TO
DWG NO. <u>E 7137</u>		- -	- -	<u>3 4</u>
ASSY PART NO.	ASSY TITLE			EFFECTED <input type="checkbox"/> NO EFFECT <input type="checkbox"/>

DESCRIPTION OF CHANGE

Change artwork, loading sketch and schematic per attached print  
Change BOM as follows:

WL#	QTY	DESCRIPTION
Change: 376-0002	from 2 to 3	7400N IC

REASON FOR CHANGE

To fix bug in the Power On Prime Circuit

NEW PURCHASE REQ'D  SHOP REWORK REQ'D  VENDOR REWORK REQ'D

CUSTOMER ENGINEERING <input type="checkbox"/> IMMEDIATE CUST <input checked="" type="checkbox"/> CUST PER NEXT CALL <input type="checkbox"/> INFORMATION ONLY <input type="checkbox"/> NONE	ACKNOWLEDGE BY _____ DATE _____	<input type="checkbox"/> MANDATORY CHANGE <input checked="" type="checkbox"/> DOCUMENTATION CHANGE (PL, BOM, DWG) <input checked="" type="checkbox"/> EASE OF MFG., COST REDUCTION <input type="checkbox"/> PRODUCT IMPROVEMENT
---	---------------------------------------	--

DISPOSITION	Bonded	FINAL ASSY AREA	SUB ASSY AREA	PARTS IN House	Outside Vendor	Future MFG.
USE AS IS TO PREVIOUS REV	X					
TO CONFORM		X	X			X
TO CONFORM IF NOT BEYOND OPERATIONS						

FINAL APPROVAL S.K. Ho  
APPROVED DESIGN ENGRG Robert Chen  
APPROVED MFG. ENGRG. D. K. Ho  
WRITTEN BY Paul A. Risher

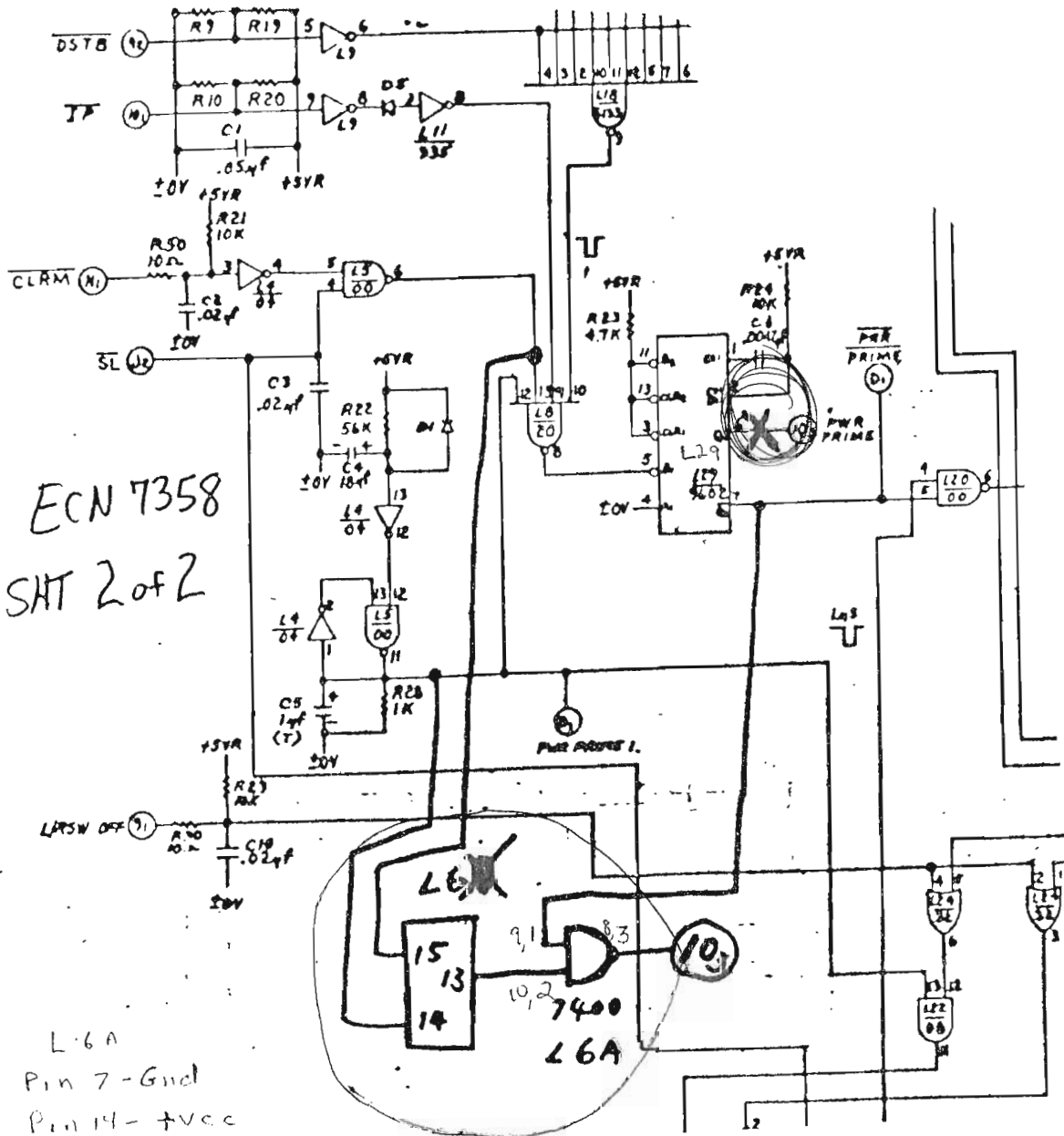
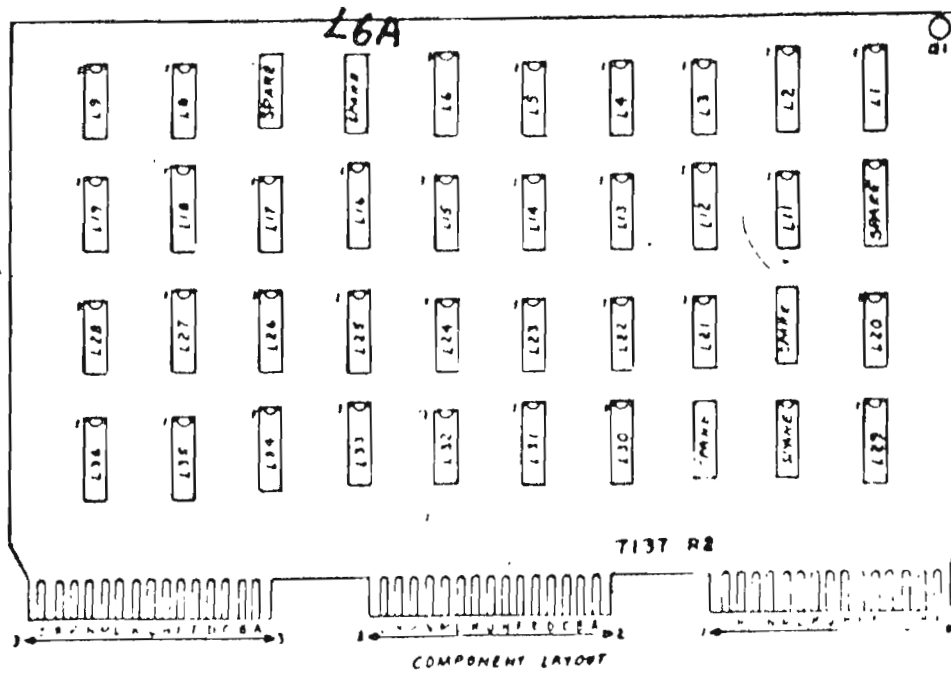

WANG

MC, WJ, KM

85

ATS  
TOPS  
INT'L

ECN

ECN No. 7712

SHEET 1 OF 2  
DATE 10-28-77  
RFA NO. (REF)

ORIGINATOR Bob Chen DEPT. 15 EXT. 2460 DATE 10/27/77  
MODEL NO. 2261W TITLE \_\_\_\_\_

7712  
ECN NO.

PART NO.	210-7136	PART NAME	PS Reg/Mtr Dr/Paper Feed	REV F	T	PC REV. FROM	TO	ELEC REV. FROM	TO
DWG. NO.	D 7136	(DWG. TITLE)		-	-	-	-	1	2
ASSY PART NO.		ASSY. TITLE						EFFECTED [ ]	NO EFFECT [ ]

DESCRIPTION OF CHANGE

Change artwork, loading sketch and schematic per attached print

Change BOM as follows:

WL#	QTY	DESCRIPTION
Add: 332-2047	1	470 Ohm 1W Resistor

REASON FOR CHANGE

To eliminate solenoid misfiring when the power is turned off

0036J

NEW PURCHASE REQ'D  SHOP REWORK REQ'D  VENDOR REWORK REQ'D

CUSTOMER ENGINEERING  
 IMMEDIATE CUST  
 CUST. PER NEXT CALL  
 INFORMATION ONLY  
 NONE

ACKNOWLEDGE  
 BY: \_\_\_\_\_  
 DATE: \_\_\_\_\_

MANDATORY CHANGE  
 DOCUMENTATION CHANGE (PI, BOM, DWG)  
 EASE OF MFG., COST REDUCTION  
 PRODUCT IMPROVEMENT

DISPOSITION	Standard	PLANT ASSY AREA	PLANT ASSY AREA	PARTS IN Vendor	PARTS Outside Vendor	Plant Mfg
USE AS IS TO PREVIOUS REV.	X					
TO CONFORM		X	X			X
TO CONFORM IF NOT BEYOND OPERATIONS EFFECTED						

FINAL APPROVAL *[Signature]*

APPROVED DESIGN ENGRG *[Signature]*

APPROVED MFG. ENGRG *[Signature]*

WRITTEN BY *[Signature]*

OCT 28 1977

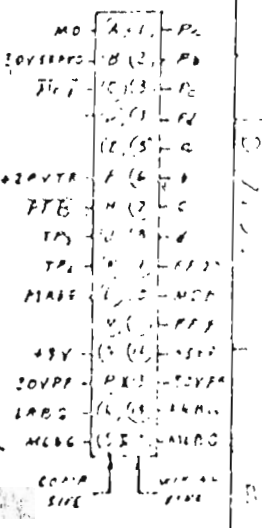
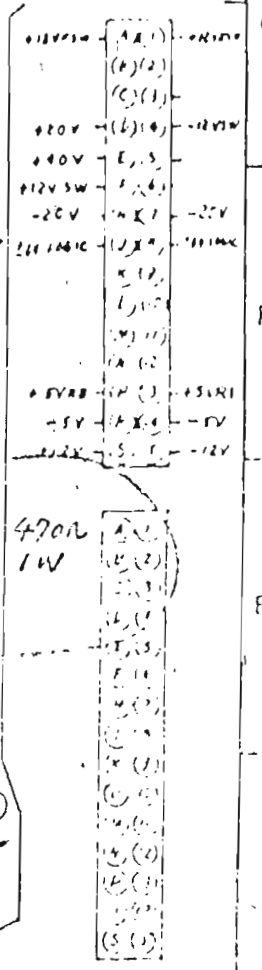
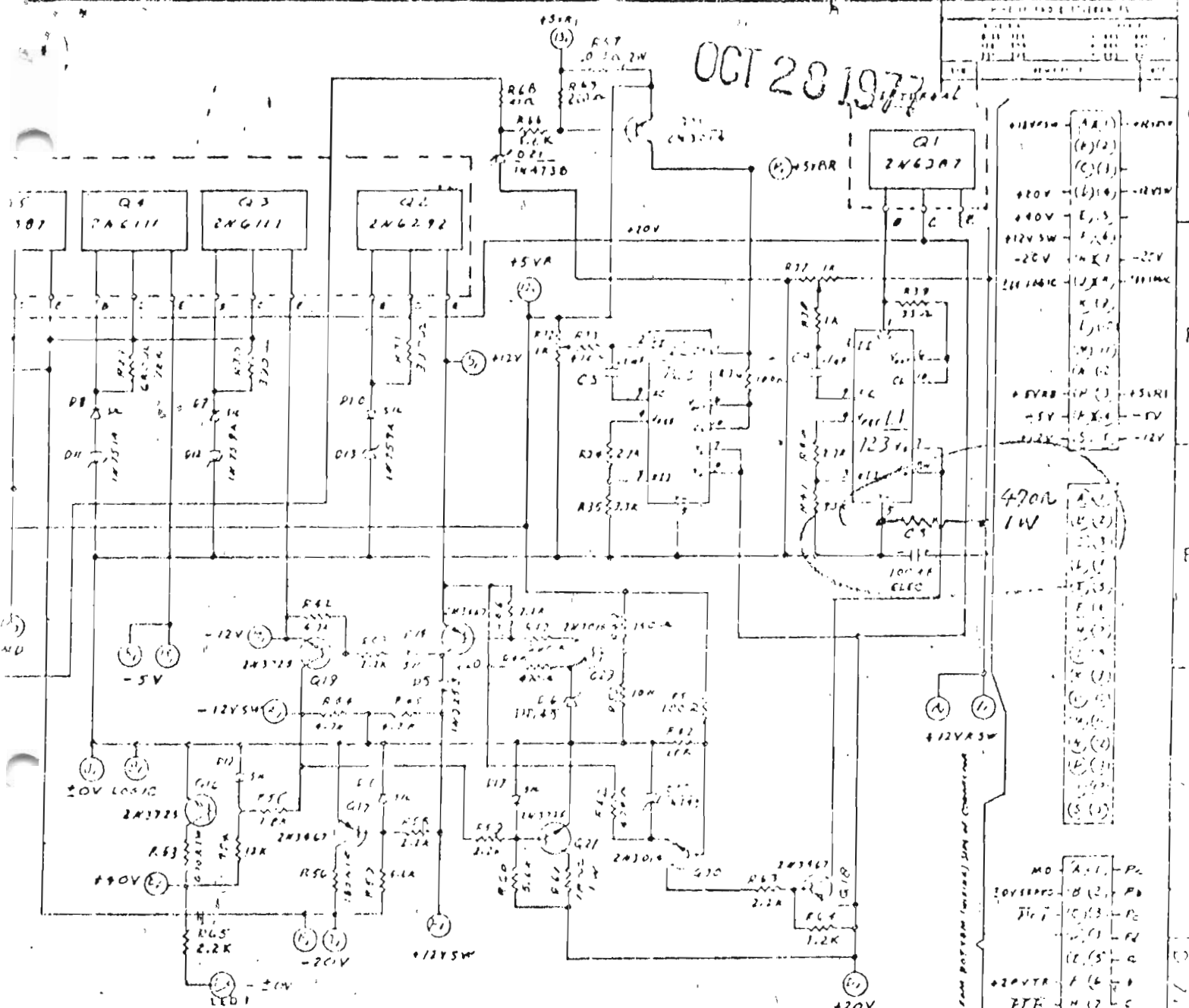

TEMPERATURE	WL PART NO
Q1, 5, 6	115-1034
Q2	115-1031
Q3, 4	225-1038
Q7, 8, 13	115-1033
Q9 - 12	225-1034
Q14, 15	315-1007
Q16, 19, 20, 21, 22	115-1027
Q17, 18, 22, 23-25	115-1026
Q26, 30, 31	115-1003
LED 1	110-0026

LOCATION	WL PART NO	PIR NO	REV	DATE
21, 2	115-0026	5		

712  
2072  
7136

(WANG)

MDL77

10-71-10-D 7136

WANG

45

ATS  
TOPS  
INT'L

ECN

ECN No. 7883

SHEET 1 OF 1  
DATE 12/17/77  
RFA NO (REV)

ORIGINATOR Barbara Kendal DEPT. 01 EXT. 581 DATE 12/5/77  
MODEL NO 61W TITLE

ECN NO 7883

PART NO. 210-7137	PART NAME	REV F T	PC REV FROM TO	ELEC REV FROM TO
DWG. NO. 7137	(DWG TITLE) I/O Interface	- -	- -	5
ASSY PART NO.	ASSY TITLE	EFFECTED NO EFFECT		

DESCRIPTION OF CHANGE

Change sample board as follows:  
 The direction of the 15uf/20V tantalum capacitor on the lefthand component side of the board is reversed. The correct polarity is + towards the fingers (See Below)

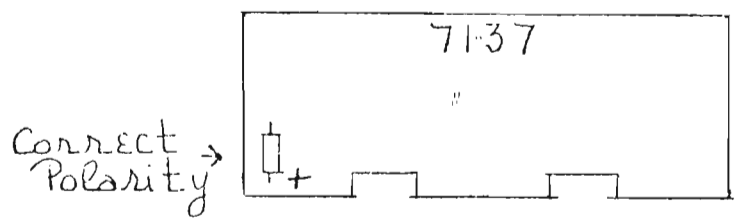

Change BOM as follows:  
 Delete: 378-2086R3  
 378-2087R3

No other documentation changes required

REASON FOR CHANGE

To correct polarity  
 320-0030 is an invalid Wang Part Number

0153J

NEW PURCHASE REQ'D  SHOP REWORK REQ'D  VENDOR REWORK REQ'D

CUSTOMER ENGINEERING <input type="checkbox"/> IMMEDIATE CUST <input checked="" type="checkbox"/> CUST PER NEXT CALL <input type="checkbox"/> INFORMATION ONLY <input type="checkbox"/> NONE		ACKNOWLEDGE BY _____ DATE: _____		<input checked="" type="checkbox"/> MANDATORY CHANGE <input checked="" type="checkbox"/> DOCUMENTATION CHANGE (PL, BOM, DWG) <input type="checkbox"/> EASE OF MFG., COST REDUCTION <input type="checkbox"/> PRODUCT IMPROVEMENT	
DISPOSITION	Produced	FINAL ASSY	ASSEMBLY	PARTS	OTHER
USE AS IS TO PREVIOUS REV	X				
TO CONFORM		X	X		X
TO CONFORM IF NOT					

FORCAST OF EASTER AREA STOCK OF 2261W PCBs AND PARTS

W/LI P/N	DESCRIPTION	TOTAL NEED	CONSIGNMENTS	AREA OFFICE	PRESENT	ORDER
<del>210-71030</del>	MOTHERBOARD					
<del>210-71129</del>	OPTICAL SCANNER					
210-71130	KBD MODULE					
210-71131	LINE BUF/CHAR GEN/PROG MEM					
210-71132	OPTICAL SIG/PAPER FD/MTR CONT					
210-71133	INTERCONNECTION PCB					
210-71134	FOUR HEAD FIRING REGISTER					
210-71136	P.S. RES/D.C. MTR DR/PAPER FD					
210-71137	8080 I/O INTERFACE					
210-71035	SINGLE HEAD SOL DRIVER					
210-71174	PHOTOTRANSISTOR PCB					
210-71175	LIGHT EMITTING DIODE PCB					

W/LI P./N	DESCRIPTION	TOTAL NEED	CONSIGNMENTS	AREA OFFICE	PRESENT	ORDER
220-3028	FLEXIBLE CABLE ASSY					
270-0420	CHASSIS ASSY W/210-7030					
279-5077-13 -12	HEAD & GUIDE TUBE <del>ASSY</del> w/ solenoid					
279-5070-14	PRINT SOLENOID <del>ASSY</del>					
279-5077-17	DRIVE MOTOR & TACH ASSY					
279-5077-19	CARRIAGE ASSY					
279-5077-23	RIBBON FEED ASSY L.H.					
279-5077-24	RIBBON FEED ASSY R.H.					
279-5077-29	FORMAT CONTROL ASSY					
279-5070-38	COVER L.H. PAPER GUIDE ASSY					
279-5070-39	COVER R.H. PAPER GUIDE ASSY					
279-5070-55	SPROCKET & BAND ASSY					
279-5070-57	SPROCKET & BAND ASSY(RH)					
279-5077-32	VERNIER CLUTCH ASSY					



W/LI P/N DESCRIPTION TOTAL NEED CONSIGNMENTS AREA OFFICE PRESENT ORDER

279-5077-16 CARRIAGE SHAFT ASSY

279-5077-45 DRIVE SHAFT & BEARING ASSY

279-5077-54 PAPER FEED MTR ASSY

279-5077-66 DOUBLE SPPOOL ~~RIBBON~~ ASSY

WLI P/N	DESCRIPTION	TOTAL NEED	CONSIGNMENTS	AREA OFFICE	PRESENT	ORDER
325-2403-M1	PAPER OUT SWITCH					
452-4050	GUIDE-CARRIGE QUAD HEAD					
451-0111	FENCE-10 PITCH-ENCODER					
461-0112	FENCE-12 PITCH-ENCODER					
451-0113	PLATE-STRIKER					
462-0285	SHIM-HEAD MOUNTING(BLUE)					
452-0286	SHIM-HEAD MOUNTING(GREEN)					
462-0287	SHIM-HEAD MOUNTING(RED)					
555-0291	BELT-CARRIAGE DR MTR					
555-0293	BELT-PAPER FEED MTR					