

MASS STORAGE DEVICES

In 1973, Wang Laboratories introduced its first Hard Disk Drive, consisting of the Diablo Series 40 Drive, and an interfacing Wang Microprocessor.

The first model introduced was designed to be used with the 700 calculators, and was named the Model 730. This unit had three levels of storage capacities; 1.2, 2.5 and 5 megabytes of storage, being a 730-1, 730-2 and 730-3 respectively.

Later versions included the 630 and 2230, all having the same storage capabilities.

In the later part of 1974, the latest version of this disk was released, the 2260. This unit has 10 megabyte storage capabilities.

The 630/730/2230 all have basically the same hardware, with the exception of the PROM Chips in the Wang Microprocessor section. All three units have a disk rotational speed of 1500 R.P.M.

The 2260 is unique in itself due to the fact that the rotational speed is 2400 R.P.M.

COMPILED BY
DEAN SATOS
MOUNTAINSIDE, NJ

PCB COMPLEMENT FOR 2230/630/730
(WANG SECTION)

341	REGULATOR
6295 ^{1,2}	I/O TERMINATOR
6296	MICROPROCESSOR
6297-1 ³	MICROPROCESSOR
6298 ⁴	RAM/ROM
6299/6398 ⁵	DISK CONTROL
6349	MOTHER BOARD
6375/6541	2200 I/O

1. Two styles of 6295 are used. Old style uses 2 Amphenol Connectors, 1 36-pin, 1 50-pin (See Fig.1). New style has two 44-pin Fingerboard Connectors.
2. For 623, 723 or 2200 operation, turn all three switch banks to the 'on' position.
3. A 6297-1 can be identified from a 6297-2 by the chips removed and jumpers installed and the missing resistor network (See Fig. 2 and 2-1).
4. A 6298 is common to all Mass-Storage Devices. The only difference from one model to another is the different removable Prom Chips; such as 730-1; 730-2; 630-1; 2230-1; 2230-2, etc. (See Fig.3).
5. For 2230 operation, a 6299 with ECN#3876 incorporated must be used. A 6398 is a new board and is equivalent to a 6299 with ECN#3876 incorporated.

I/O CABLE CHANGES

To change a 630/730 I/O Cable to a 2230 I/O Cable, the following wire must be changed:

<u>END</u>	<u>WIRE FROM</u>	<u>WIRE TO</u>
AMPHENOL	PIN 33	PIN 11
FINGERBOARD	PIN 13	PIN 10



LABORATORIES, INC.

ALL DISK PROM LAYOUT AND REV. NUMBERS

MODEL	L8	L7	L6	L5	L4	L3	L2	L1
630-1	0187	0185			0186-R1	0184		
630-2	181-187	0189			150R1-186R1	0188		
630-3	185-187	0193			141R1-186R1	0192		
730-1	0166	0164			0165-R1	0163		
730-2	170-166	0168			169R1-165R1	0167		
730-3	170-166	0172			113R1-165R1	0171		
2230-1	0199-R1	0197-R1		0201-R1	0198-R1	0196-R1		0200-R1
2230-2	205R1-199R1	0203-R1		204R1-201R1	204R1-198R1	0202-R1		206R1-200R1
2230-3	211R1-199R1	0209-R1		213R1-201R1	210R1-198R1	0208-R1		212R1-200R1
2260	0359	0357		0361	0358	0356		0360
640-1	230-R3	0228-R1			229-R3	0227-R1		
640-2	234R3-230R3	0232-R1			233R3-227R3	0231-R1		
740-1	0217-R1	0215		0219-R2	0216	0214		0218-R2
740-2	223R1-217R1	0221		223R2-219R2	222-216	0220		224R2-218R2
2240-1	0238-R3	0236-R5			0237-R3	0235-R5		
2240-2	242R3-238R3	0240-R5			241R3-237R3	0239-R5		
2242	282R3-238R3	0280-R2			281R3-237R3	0279-R3		
2243	0286-R5	0284-R6			0285-R4	0283-R6		

FIG:3

L1 is the first chip of the set. This chip is always located as the first 24 Pin I.C. socket located at the upper right had corner, looking at the component side facing you.

Fig. 1

6295 I/O Terminator Board (Old Style)

NOTE: USUALLY FOUND ONLY IN THE 730 MODEL

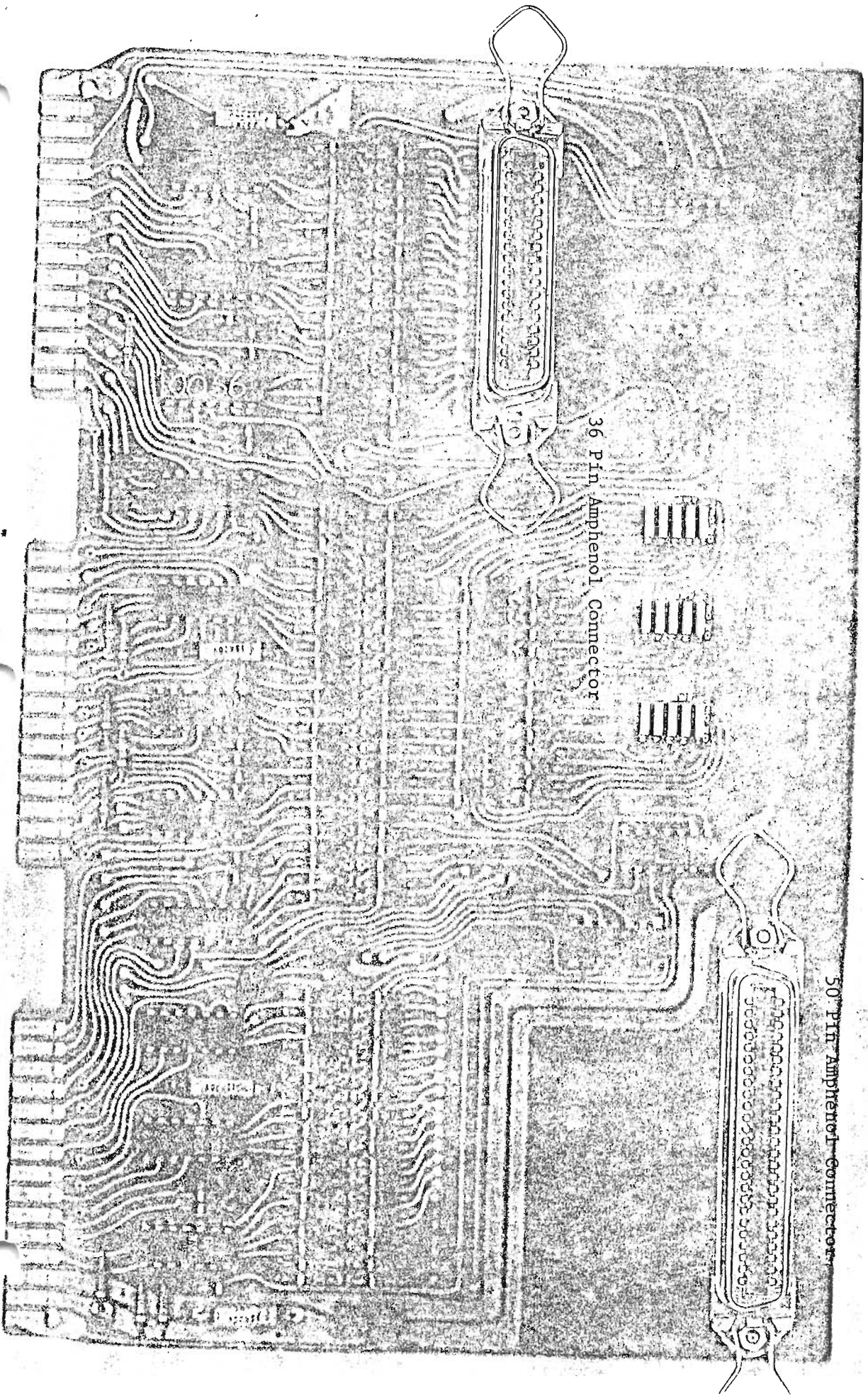

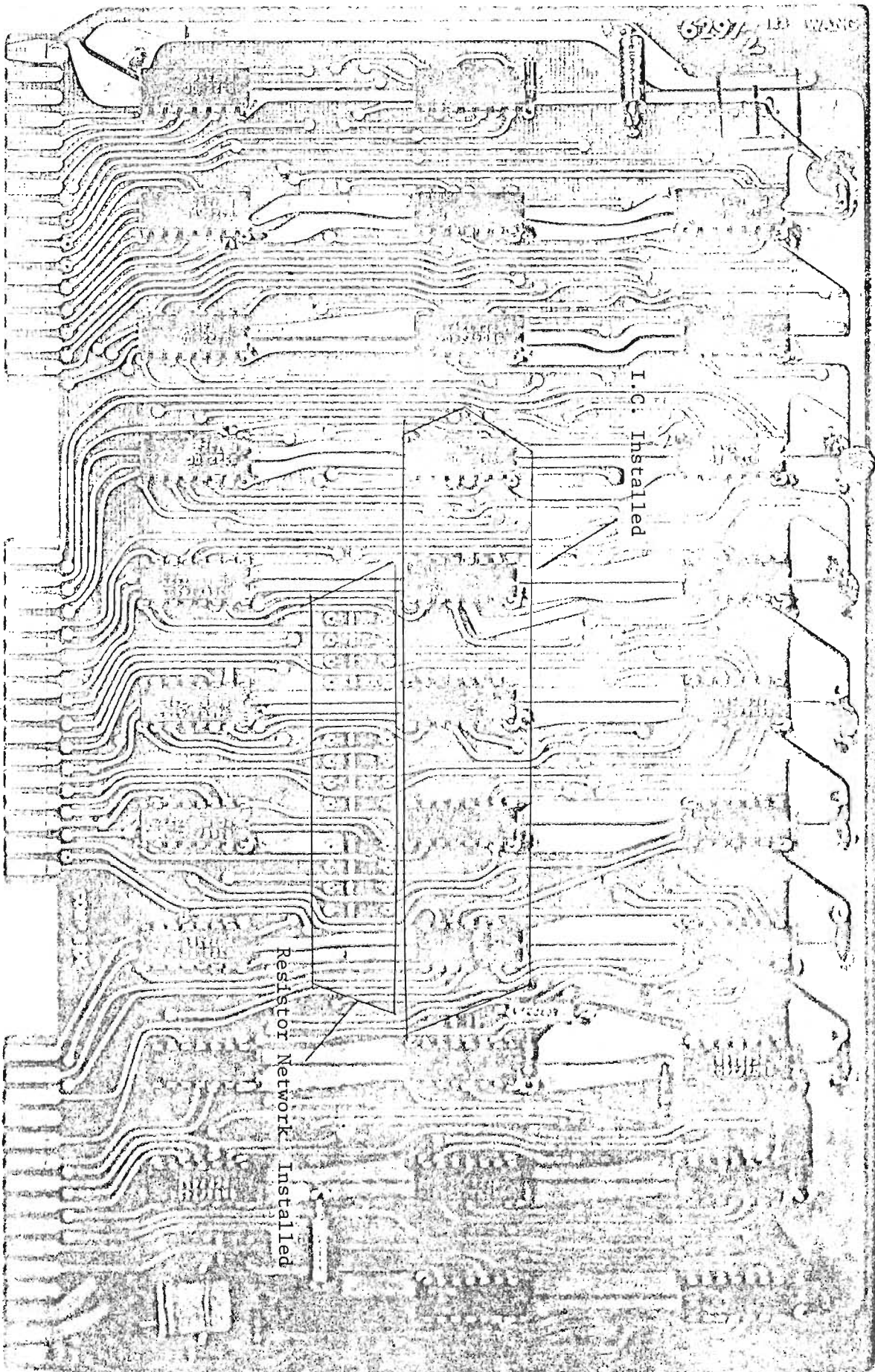
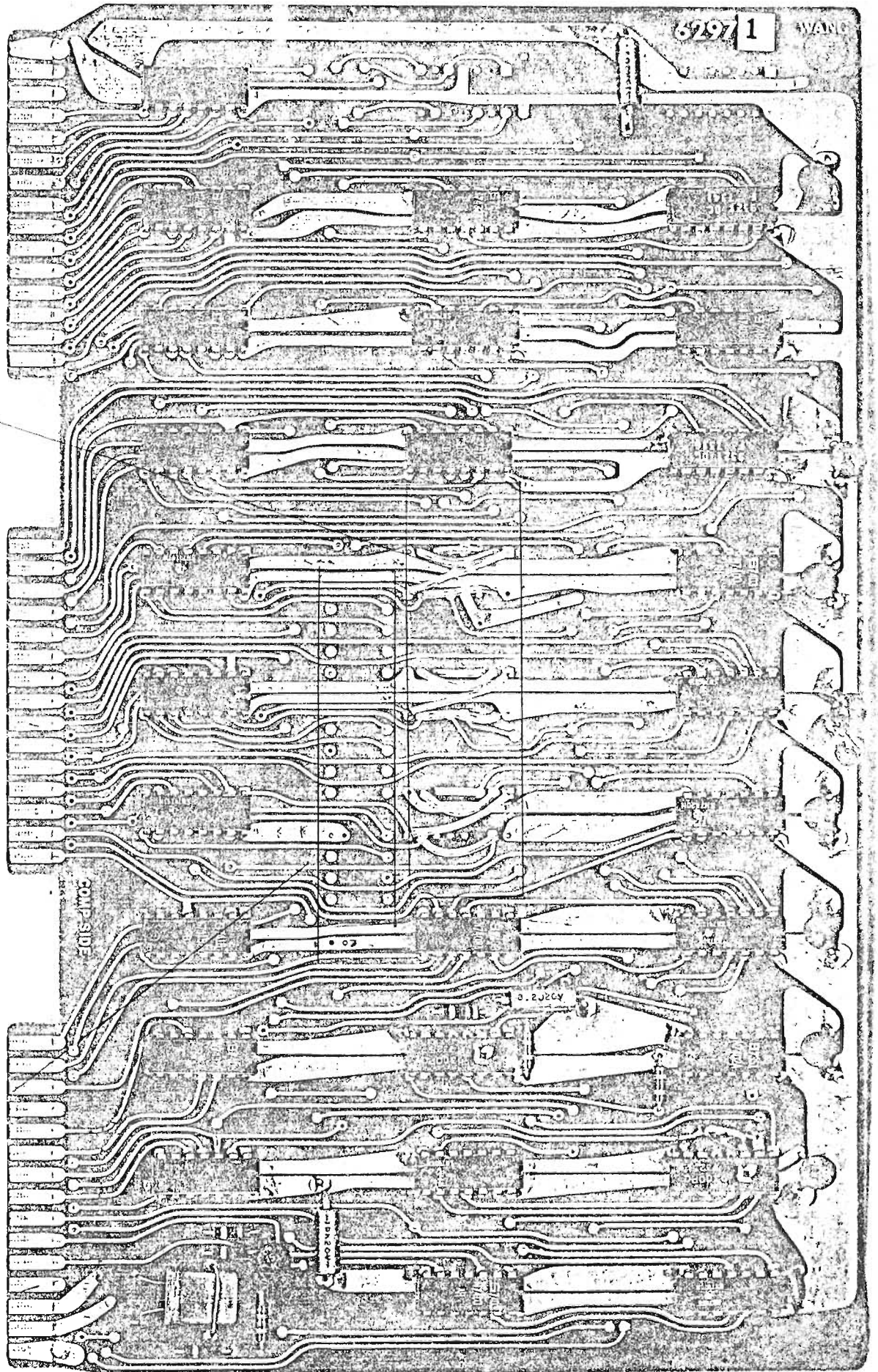

Fig. 2 6297-2



Jumpers in place of I.C.

Resistor Network removed

Fig. 2-1

6297-1

DIABLO SERIES 40 P.C. LAYOUT

← COMPONENT SIDE

I/O-1 I/O-3 I/O-4 I/O-5 I/O-6 I/O-2

I/O1	11431	REV 01
	OR	
RDR1	11643	REV 01
SC	11459	
	SPARE	
D/CS	11429	REV 00
	OR	
	11637	REV 00
	SPARE	
I/O2	11433	
	OR	
RDR2	11645	REV 00

I/O CARD CAGE FOR
11521 I/O MOTHERBOARD

← COMPONENT SIDE

I/O1	11431	REV 01
	OR	
RDR1	11643	REV 01
SC	11459	
	SPARE	
D/CS	11429	REV 00
	OR	
	11637	REV 00
	SPARE	
	SPARE	
I/O2	11433	
	OR	
RDR2	11645	REV 00

I/O CARD CAGE FOR
11400 I/O MOTHERBOARD
(Early Version of Diablo)

FIGURE 2

← COMPONENT SIDE

SD	11613	REV 01
OR	11414	REV 00
	SPARE	
TC	SPARE	(2260 only)
SL	11471	REV 00
SR	11411	REV 01
SO	11633	REV 00
AL2	11407	REV 00
AL1	11404	REV 00

MAIN CARD CAGE WITH
11635 MOTHERBOARD

Heat Sink Board 11631-01
Read/Write Board 11486-02

EDITED BY PRODUCT SERVICE DEPT.

MODEL 30
WANG/DIABLO DISK DRIVE



NOTICE:

This document is the property of Wang Laboratories, Inc. Information contained herein is considered company proprietary information and its use is restricted solely to the purpose of assisting you in servicing Wang products. Reproduction of all or any part of this document is prohibited without the consent of Wang Laboratories.



LABORATORIES, INC.

836 NORTH STREET, TEWKSBURY, MASSACHUSETTS 01876, TEL. (617) 851-4111, TWX 710 343-6769, TELEX 94-7421

Printed in U.S.A.
13-210

TABLE OF CONTENTS

1.	GENERAL	3
1.1	Description	3
1.2	Special Features	5
1.3	Hardware Nomenclature	5
1.4	Diablo Model 429 Power Supply	17
2.	MODEL 30 INSTALLATION	21
2.1	General Description	21
2.2	Procedure	21
3.	OPERATION - SOFTWARE	32
3.1	Operating Configuration	32
3.2	Power On Procedure	32
3.3	Loading and Unloading the Removable Disk Cartridge	33
3.4	Selecting the Disk Unit	36
3.5	Fixed and Removable Disk Format Checks	37
3.6	Handling and Storage of the Removable Disk Cartridge	46
3.7	Machine Interlocks	46
3.8	Check List	47
3.9	Read/Write Commands	48
3.10	Legal Sector (Block) Addresses	52
3.11	Indicator Lights and Switches	53
4.	730 DATA DIAGNOSTIC	60
4.1	Description	60
4.2	Diagnostic Operating Instructions	62
4.3	Additional Program Information	62
5.	MAINTENANCE PROCEDURES	65
5.1	General Information	65
5.2	Preventive Maintenance	65
5.3	Preventive Maintenance Procedures	66
5.4	Circuit Boards - Diablo	66
5.5	Alignments	67
5.6	Model 429 Power Supply Maintenance	76
5.7	Model 30 Conversions	77
5.8	Controller Voltage Checks	78
5.9	Service Notes	78
6.	APPENDIX - DIAGRAMS	79

MODEL 30 DISK

1. GENERAL

1.1 DESCRIPTION

The MODEL 30 is a DIABLO disk drive having two disk cartridges, one fixed; the other removable. There is one set of access arms for each disk. Each disk contains up to 2.5 million bytes of data, formatted into two surfaces, each of up to 200 tracks, and each track is divided into 24 sectors. Each sector is formatted by the WANG controller into a 2-byte sector address, 256 bytes of data, and a 2-byte cyclic redundancy check (CRC). The 2-byte sector address and 2-byte cyclic redundancy check are transparent to the software and are used by the controller to maintain data integrity. The CRC code is a highly reliable data check. Only 256 byte (program steps) transfers are allowed with the disks. One byte transfers are allowed with the controller.

Using a 700/720C calculator, the procedure to perform a read or write on the *disk* is as follows:

- (a) Key the desired sector address into the Y register.

NOTE:

All sectors on a given platter are contiguous.
That is, sectors 0-23 are on track zero, sectors
24-47 are on track one, etc.

- (b) Key the step number where the transfer is to begin into the X register.
- (c) Key the appropriate command for a 256-step read or write.

The controller will then seek the proper disk cartridge, track and sector. When the desired sector has been reached, the controller will compare the 2-byte sector address recorded on the disk cartridge with the sector address in the Y display to insure that the proper location has been reached. The 256 bytes of data will then be transferred. For a write, the controller will develop and record a 2-byte CRC code against the transferred data. For a read, the controller redevelops the 2-byte CRC code and compares with the CRC code recorded at the sector being addressed.

The following is a table of valid sector addresses:

	<u>730-1</u>	<u>730-2</u>	<u>730-3</u>
Fixed Disk	0-2399	0-4799	0-9599
Removable Disk	1,048,576- 1,050,975	1,048,576- 1,053,375	1,048,576- 1,058,175

NOTE:

There is a large gap in addresses between the fixed and removable disk for the following reasons:

- 1) To be able to distinguish between the fixed and removable disk.
- 2) For future expansion.

MODEL -30 CAPACITY

MODEL	TOTAL CAPACITY	
730-1, 2230-1	1,228,800 bytes	(1.2 megabytes)
730-2, 2230-2	2,457,600 bytes	(2.5 megabytes)
730-3, 2230-3	4,915,200 bytes	(4.9 megabytes)

Each MODEL 30 contains one fixed and one removable disk with one half of the total storage capacity on each cartridge.

1.2 SPECIAL FEATURES

The MODEL 30 provides two other features:

- (a) Compare the contents of 700/720C memory (256 bytes) with a sector on the disk. If the memory contents are not identical with the sector contents, the program error light of the 700/720C will be illuminated.
- (b) The MODEL 30 *controller* has a special one byte memory which can be loaded or its contents retrieved by the calculator.

1.3 HARDWARE NOMENCLATURE

1.3.1 *Electronics Description - DIABLO PORTION.*

Electronic subassemblies are contained in five areas within the DIABLO section of the MODEL 30. See Figure 1 below:

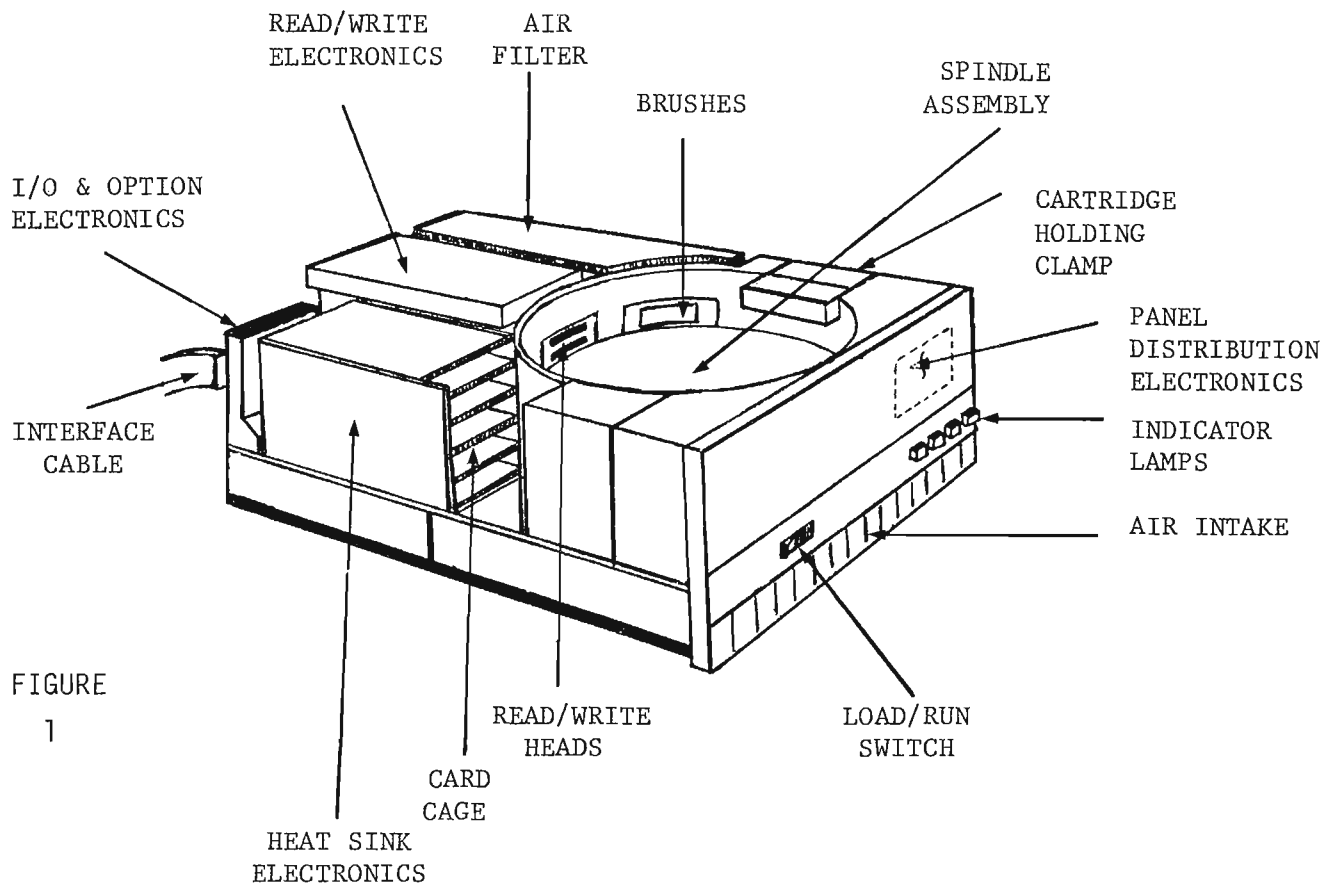

FIGURE
1

1) Input/Output Box (I/O and Option Box)

The I/O and option box is attached to the rear of the MODEL 30 as shown in Figure 1. The I/O and option box may accommodate up to six circuit boards. Two of these circuit boards contain line drivers and line receivers, the remaining four circuit board positions contain the optional feature circuits installed on the machine. See layout below (Figure 2). The options featured on each PC is as follows:

- (a) Line driver/receiver - RDR1, DIABLO #11643
- (b) Sector Counter - SC, DIABLO #11459
- (c) Data/Clock Separator - D/CS, DIABLO #11637
- (d) Line driver/receiver - RDR2, DIABLO #11645

FIGURE 2

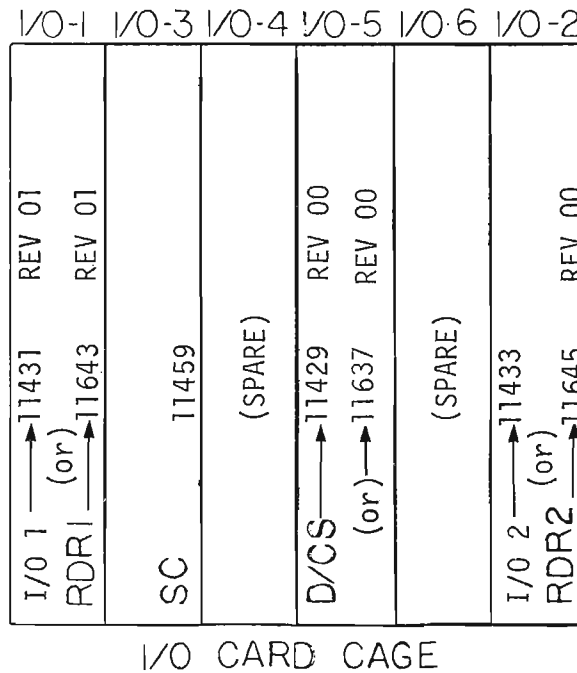

2) Electronic Card Cage

The electronic card cage in Figure 1 contains seven plug-in circuit boards. The individual circuit boards are listed. Figure 3 below describes physical layout. Each PC board is labeled according to Function on the component side.

- (a) Oscillator board - OR, DIABLO #11414
- (b) Sequence logic board - SL, DIABLO #11471
- (c) Spindle drive board - SD, DIABLO #11613
- (d) Sensor circuit board-SR, DIABLO #11411
- (e) Address logic board - AL1, DIABLO #11404
- (f) Address logic board 2 - AL2, DIABLO #11407
- (g) Servo circuits - SO, DIABLO #11633

FIGURE 3

SD	11613	REV 01
OR	11414	REV 00
	(SPARE)	
TC	(SPARE)	
SL	11471	REV 00
SR	11411	REV 01
SO	11633	REV 00
AL2	11407	REV 00
AL1	11404	REV 00

MAIN CARD CAGE

3) Read/Write Electronics R/W - DIABLO #11486, REV. 02

This circuit board is mounted in a sealed box above the voice coil actuator. See Figure 1.

4) Heat Sink Electronics HS - DIABLO #11631, REV. 01

This circuitry is mounted on the outside of the electronic card cage. See Figure 1.

5) Panel Distribution PD - DIABLO #11499

This circuitry distributes signal levels and functions to the various areas of the MODEL 30. See Figure 1.

6) Card Cage Motherboard - DIABLO #11635

All card cage PC boards are plugged into this board. See Figure 3.

1.3.2 *Electronics Description - WANG PORTION.*

The following PC boards are located in the controller chassis:

6295	TERMINATOR
6296	MICROPROCESSOR
6297	MICROPROCESSOR
6298	RAM/ROM
6299	DISK CONTROL
6349	MOTHERBOARD

Figure 4 illustrates physical layout.

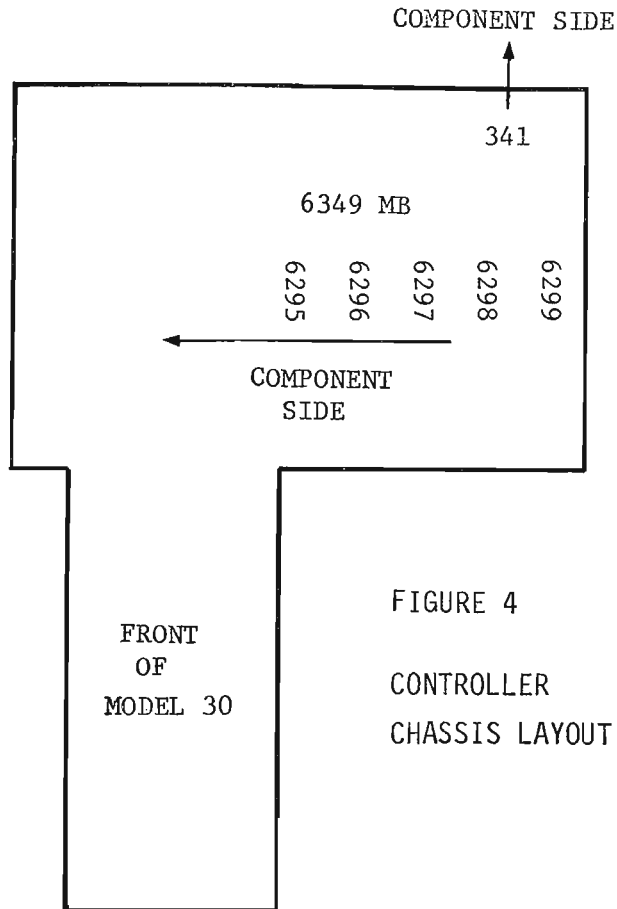

1.3.3 Disk Cartridge Description.

(a) General

An IBM 5440 or equivalent type cartridge is suitable for use with the MODEL 30. Most standard cartridges are suitable for 100 or 200 tracks per inch, and 2200 bits per inch, data packing density. The standard 5440 cartridge has slots from which index marks (timing marks) are produced. The 5440 disk cartridge is available from most cartridge manufacturers with the index and a fixed number of physical sector slots provided. (Example: Nashua Corp. #5440-24)

The index circuit of the selected disk supplies its timing pulses, to the disk interface. Internally, the index mark is delivered to the spindle speed control circuits.

(b) Design Information

In each disk unit there are two disks; one fixed and one removable. Each disk has two usable surfaces, top and bottom. Thus there are four usable surfaces in each disk unit (Figure 5).

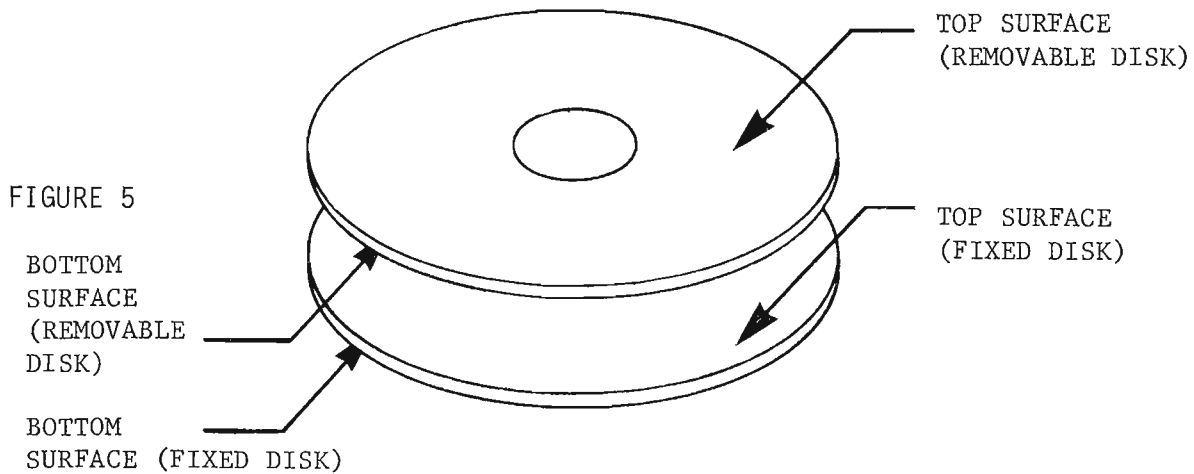

Each surface of a disk contains 50, 100 or 200 tracks, depending upon the unit model. The tracks on a disk are a series of concentric circles radiating out from the center of the disk. The lowest numbered track on each surface is at the outside rim. The tracks are numbered oddly on the top surfaces and evenly on bottom surfaces.

Each track is divided into 24 blocks of information. Beginning with sector 0 and addressing ascending sectors, the disk controller writes the first 24 blocks of information on the bottom track, then writes the next 24 blocks of information on the top track and alternates as such. Which disk is used (Fixed or Removable) is determined by the block (sector) address given in the calculator Y register.

Each block on a track contains 260 bytes, of which only 256 are available to the user. Thus, each track contains $256 \times 24 = 6144$ available storage bytes. Figure 6 shows a block (sector) of a track.

FIGURE 6

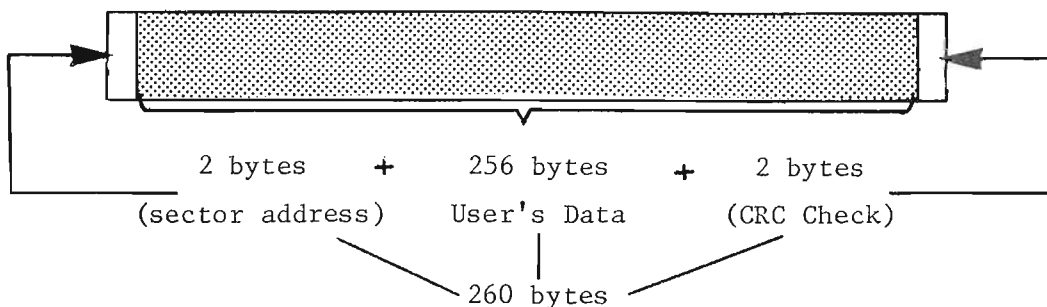

The first two bytes of each sector contain the block address prerecorded on the disk by the formatting procedure to be discussed in the Operations section of this bulletin.

The last two bytes are for a Cyclic Redundancy Check (CRC), which is automatically recorded when data is written onto the disk. The CRC check verifies for the system that data is transferred from the disk to the controller correctly.

Only 256 bytes (a block) of user's information can be written or read from a disk at any one time. The table below lists the number of tracks and storage bytes available on each model of the disk.

Type of Disk	FIXED		REMOVABLE		Total Tracks	Available Storage (bytes)
	Top	Bottom	Top	Bottom		
730-1	50	50	50	50	200	1,288,800
730-2	100	100	100	100	400	2,457,600
730-3	200	200	200	200	800	4,915,200

NOTE:

Smaller models of the disk can be field retrofitted to a larger model.

(c) How Tracks Are Numbered (Cylinders)

If a disk has 50 tracks on each surface (e.g. 730-1), this does not mean that the tracks on each surface are numbered 1 - 50 consecutively.

The bottom surfaces are numbered evenly and the top surfaces are numbered oddly. The track numbers on the top surfaces are 1,3,5....97,98 and on the bottom surfaces they are 0,2,4,...96,98. Both disks (FIXED and REMOVABLE) are numbered the same. See Figure 7. A TRACK on the top surface is directly above a TRACK on the bottom surface, which means TRACK 1 is directly above TRACK 0, TRACK 3 above TRACK 2 and so on.

FIGURE 7

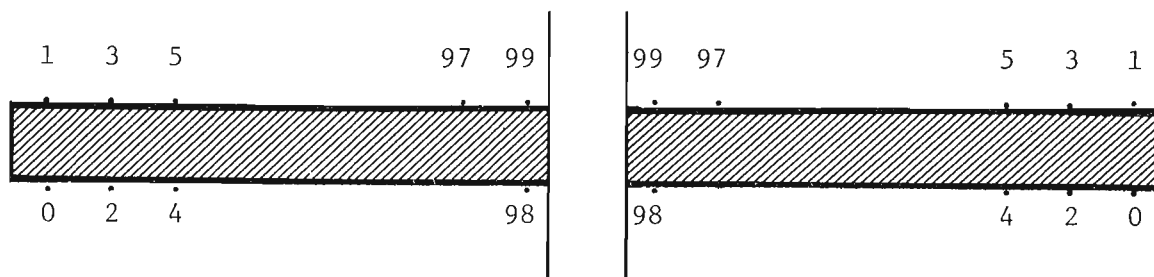

CROSS SECTION OF A DISK
SHOWING TRACK NUMBERING

TRACK NUMBERING

MODEL	TOP/BOTTOM	FIXED		REMOVABLE	
		No of Tracks	How Numbered	No of Tracks	How Numbered
730-1	Top	50	1,3,5,...99	50	1,3,5,...99
	Bottom	50	0,2,4,...98	50	0,2,4,...98
730-2	Top	100	1,3,5,...199	100	1,3,5,...199
	Bottom	100	0,2,4,...198	100	0,2,4,...198
730-3	Top	200	1,3,5,...399	200	1,3,5,...399
	Bottom	200	0,2,4,...398	200	0,2,4,...398

Since the REMOVABLE disk sits directly above the FIXED disk, tracks 0 and 1 of the REMOVABLE disk are directly above, or in the same *plane* as tracks 0 and 1 of the FIXED disk. This plane is called a *cylinder*. It is given this name because if all four tracks in the same plane are connected by imaginary lines, a cylinder is formed. (See Figure 8 below.)

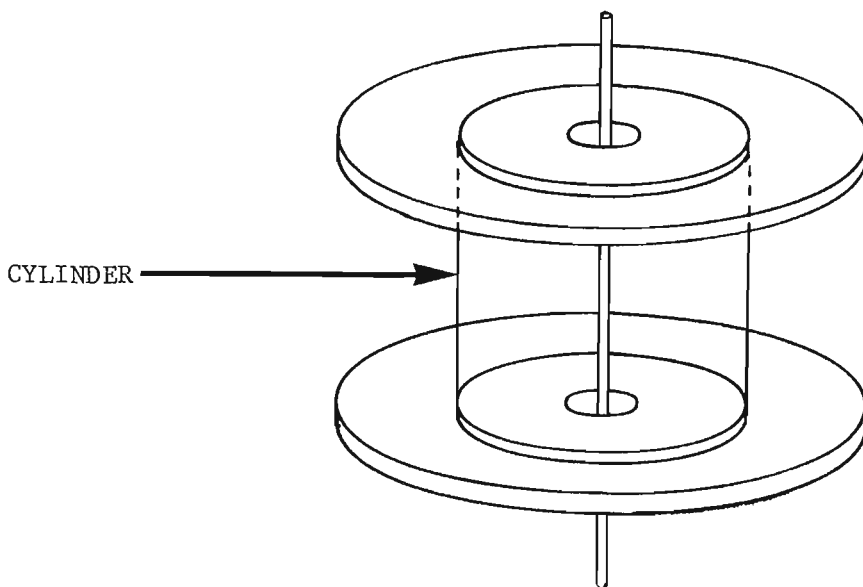

FIGURE 8

This concept of a *cylinder* is important to a programmer, in order to READ or WRITE data on the disk in the most timesaving way.

Data is READ and WRITTEN onto a disk by means of READ/WRITE heads. There are four, one for each disk surface. These heads move in and out, across the surfaces of the disk. One head at a time writes or reads a SECTOR on a TRACK. If a programmer can eliminate excessive lateral movement of these heads, much reading or writing time can be saved. This is done by keeping the heads in the *same cylinder* as long as possible. Cylinder 1010 for example is Tracks 1 and 0 of the top disk and Track 1 and 0 of the bottom disk. There are then 4 tracks, or $4 \times 24 = 96$ sectors or $4 \times 24 \times 256 = 24,576$ bytes of storage in this one cylinder.

Many program steps or data can be read or written without the heads having to be moved laterally.

There are 50 cylinders in the 730-1, 100 cylinders in the 730-2 and 200 cylinders in the 730-3.

(d) How Sectors Are Numbered (Block Addresses)

In order to manually manage the disk, the pattern of where sector addresses are recorded must be known.

SECTOR/TRACK DIAGRAM

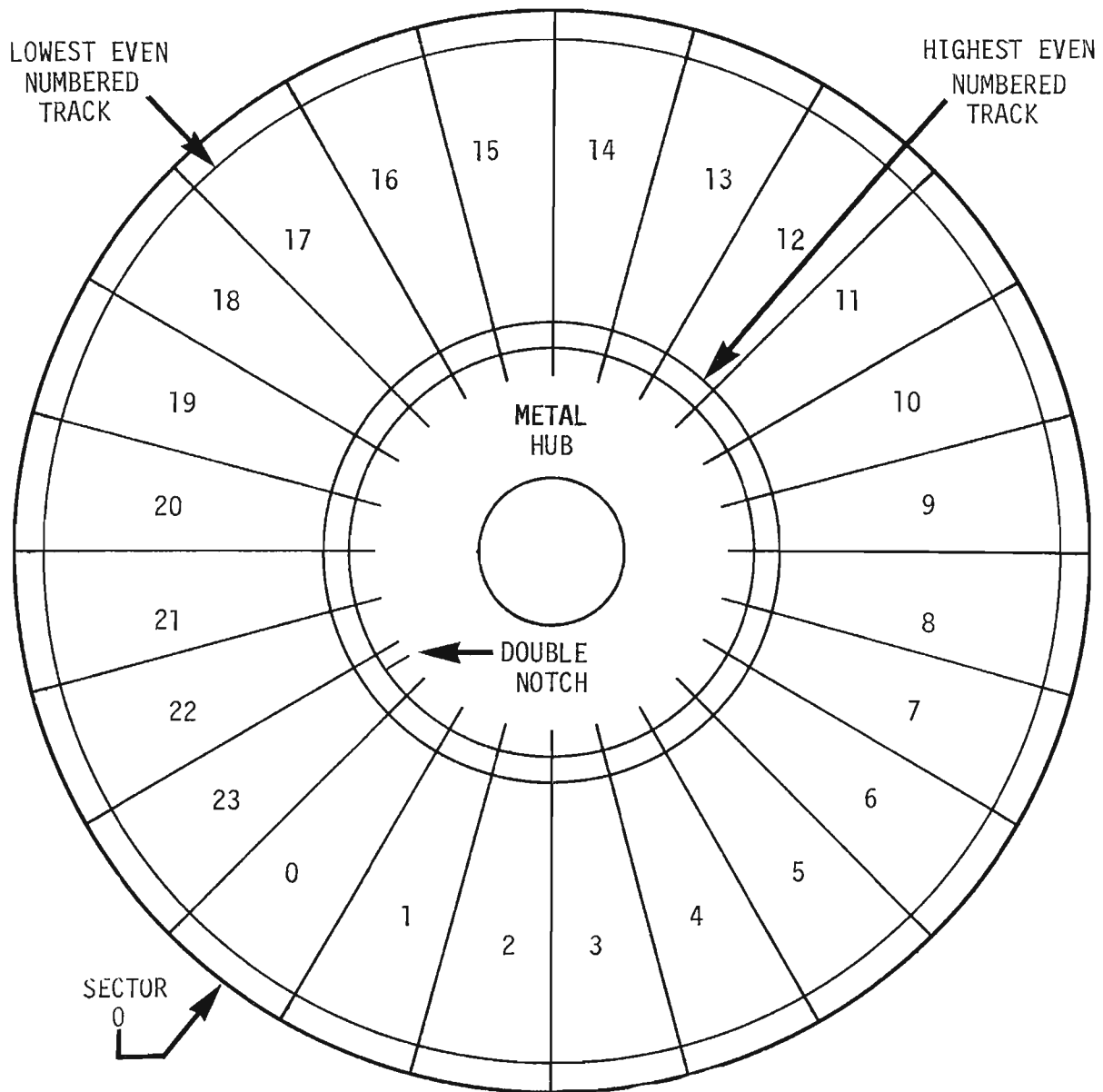

BOTTOM SURFACE LAYOUT

1.3.4 Model 30 Transfer Times.

The time to transfer a 256 byte sector to or from the calculator is made up of the following components:

- | | |
|---|---|
| (a) Time to process 700 command. | 1.5 ms average |
| (b) Access time - time the disk takes to reach the proper track. | 8 ms to adjacent track
38 ms average |
| (c) Disk latency time - time the disk takes to rotate to the proper sector on the track. | 20 ms average
@ 1500 RPM |
| (d) CPU to DISK or DISK to CPU transfer time - time the 720C takes to retrieve or store the data from or to memory. | 6.4 ms |
| (e) AVERAGE TIME to transfer a disk sector at a random address is | 65.9 ms |

1.3.5 Model 30 Operating Facts.

(a) Operating Environment

The disk drive should be operated in an ambient temperature range between 50° and 100°F. If the temperature range is exceeded, data may not be readable on a disk drive operating at the other end of the temperature range. Thus, even though the equipment may not be damaged, interchangeability of disk cartridges may be impaired. However, if the disk drive is allowed to return to room temperature for approximately two hours, the equipment should again be operable.

(b) Power

Input 115 VAC @ 9 amps, or 230 VAC @ 5 amps, 50 or 60 Hz.

(c) Cleaning the Disk

The disks are automatically cleaned every time the RUN/LOAD switch is turned to RUN. Internal cleaning brushes automatically sweep the disks to remove any dust.

(d) PRIME Key

The PRIME key on the calculator, when touched while the disk is running, discontinues any disk action. The selection of the disk remains intact.

(e) Filter

The air filter in the disk needs to be changed every six months.

1.4 DIABLO MODEL 429 POWER SUPPLY

1.4.1 *General Description And Use.*

This bulletin describes the installation, operation, and maintenance of the Diablo Systems, Inc., Model 429 Power Supply. The power supply is designed specifically to provide the power required by one Diablo Series 40 Disk Drive. Circuit configuration was selected to accommodate the peculiarities of the dynamic load presented by the Series 40 Disk Drive. Nominal output voltages of the Model 429 are +24 VDC, -24 VDC, and +5 VDC.

Combined static and dynamic output voltage variation does not exceed $\pm 8\%$ for the 24 volt outputs and $\pm 3\%$ for the 5 volt output under worst-case conditions of temperature, input voltage, frequency, and load.

A ferroresonant constant-voltage transformer is utilized in the design. The power supply operates from a primary power source of either 115 VAC or 220 VAC, selectable by taps on the power transformer windings. Taps also allow the use of either 60 Hz or 50 Hz primary power. Line voltage and frequency variations of $\pm 10\%$ and ± 1 Hz, respectively, can be tolerated without degradation of power supply performance.

Although the DC output voltages are available at terminal posts with clamp screws, the power supply comes with a six-foot DC power cable assembly using a Winchester connector assembly with socket contacts.

The 5 VDC circuit has an overvoltage protection feature which operates if the output exceeds approximately 6 VDC. Current limiting is at a nominal 7 amperes for the 5 volt output. Each output is fused, as is the input line.

1.4.2 *Specifications.*

The table below lists the specifications for the DIABLO Model 429 Power Supply. The specifications are for operation at rated load unless otherwise indicated.

<u>Parameter:</u>	<u>Specification:</u>
Input Voltage	115 VAC or 220 VAC, $\pm 10\%$ 50 Hz or 60 Hz, ± 1 Hz (tapped transformer windings allow selection)

Parameter:

Specifications:

Input current:

115V 60 Hz	5.2A \pm 10%
115V 50 Hz	5.2A \pm 10%
220V 60 Hz	2.6A \pm 10%
220V 50 Hz	2.8A \pm 10%

Rated Load

+24 VDC @ 5.5A
-24 VDC @ 5.5A
+5 VDC @ 4A

Output:

Nominal Output	+24 VDC
	-24 VDC
	+5 VDC

Combined Ripple & Voltage variation caused by dynamic load	\pm 8% peak-to-peak for \pm 24 VDC \pm 3% peak-to-peak for +5 VDC
--	--

Peak Current	17A total on +24 VDC and -24 VDC
--------------	----------------------------------

Overvoltage Protection Level,

5 volt supply	6 VDC \pm 0.5V
---------------	------------------

Foldback Current Limit,

5 volt supply	Nominal 7A
---------------	------------

Output impedance of 5 VDC supply

@ 2.5 MHz	<0.01 Ω
-----------	----------------

Power Consumption

<420W

Efficiency

>65%

Parameter:

Specifications:

Environmental:

Operating Ambient Temperature	25° C \pm 15°
Storage Temperature	-55° C to + 85° C

Physical

Height	3.27 inches
Width	8.156 inches
Depth	18.0 inches
Weight	31 pounds

The unit is connected at the factory for an input of 115 V, 60 Hz. If operation from a different power source is necessary, removal of the cover and changes in the transformer connections are required.

2. MODEL 30 INSTALLATION - See Figures 9 - 18

2.1 GENERAL DESCRIPTION

The WANG MODEL 30 DISK DRIVE UNIT arrives in four (4) separate boxes:

Box #1 - Contains one removable (top) disk cartridge.

Box #2 - Contains DIABLO/Model 43 disk drive unit and interfacing cables.

Box #3 - Contains Diablo Power Pack.

Box #4 - Contains main frame, cover, controller electronics, and power supply clamp.

2.2 PROCEDURE

The unpacking for boxes #1 and #3 requires no procedure. Follow the procedure below for unpacking boxes #2 and #4, and unit installation.

- 1) On the bottom of box #2 a cardboard box manufacturer's label can be seen. This side of the box should be facing UP while opening box #2.
- 2) Another box will be found inside #2. Open the second box without removing it from #2.
- 3) A heavy plywood base *BOLTED* to the bottom of the unit should be found at this time.

- 4) Before removing the disk unit, be sure that some soft padding (rug, packing foam, etc) is spread on the floor where the unit will be laid down.
- 5) Two individuals should grasp the bolted plywood base, gently lift out the disk unit, and set it down (upside down at this point) on the padding. See Figure 9. Remove the interface cables from box #2.

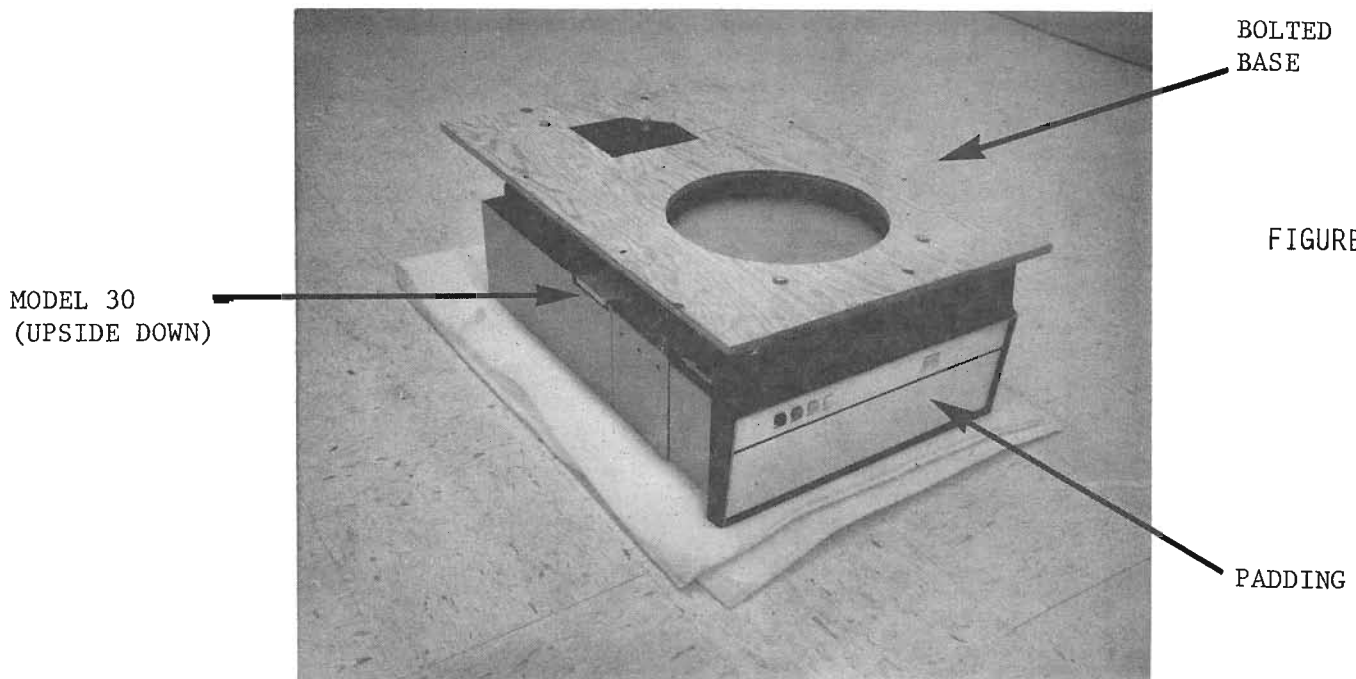

FIGURE 9

- 6) Open box #4 and remove main frame/controller electronics. *Carefully* remove controller electronics completely from main frame and set on floor.

- 7) CAUTION: Before installing the power supply, insure that the wires routed near the fan, as shown in Figure 10, are not protruding over the metal flange of the controller. This prevents severing of the wires by the power supply chassis.

CONTROLLER
ELECTRONICS

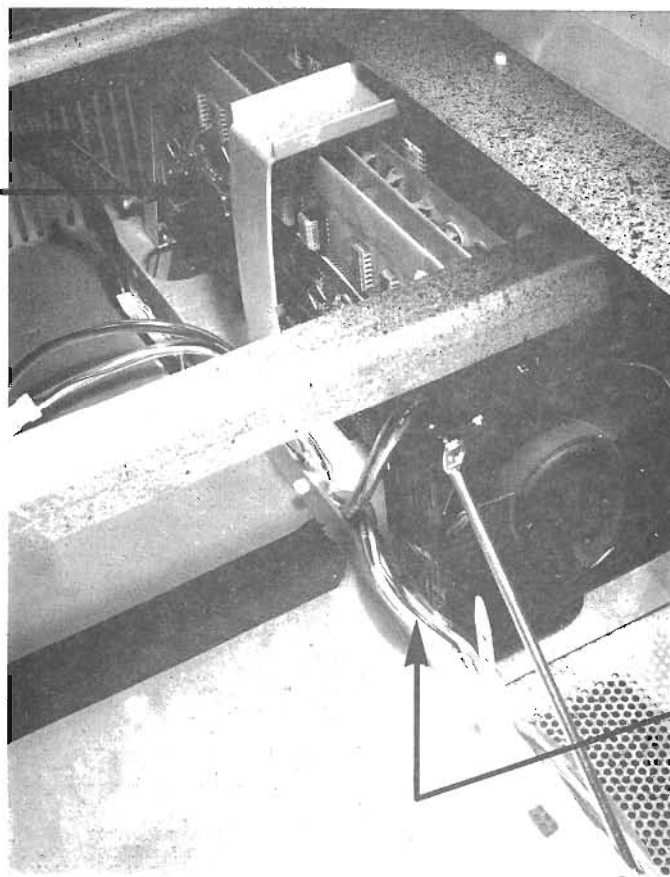
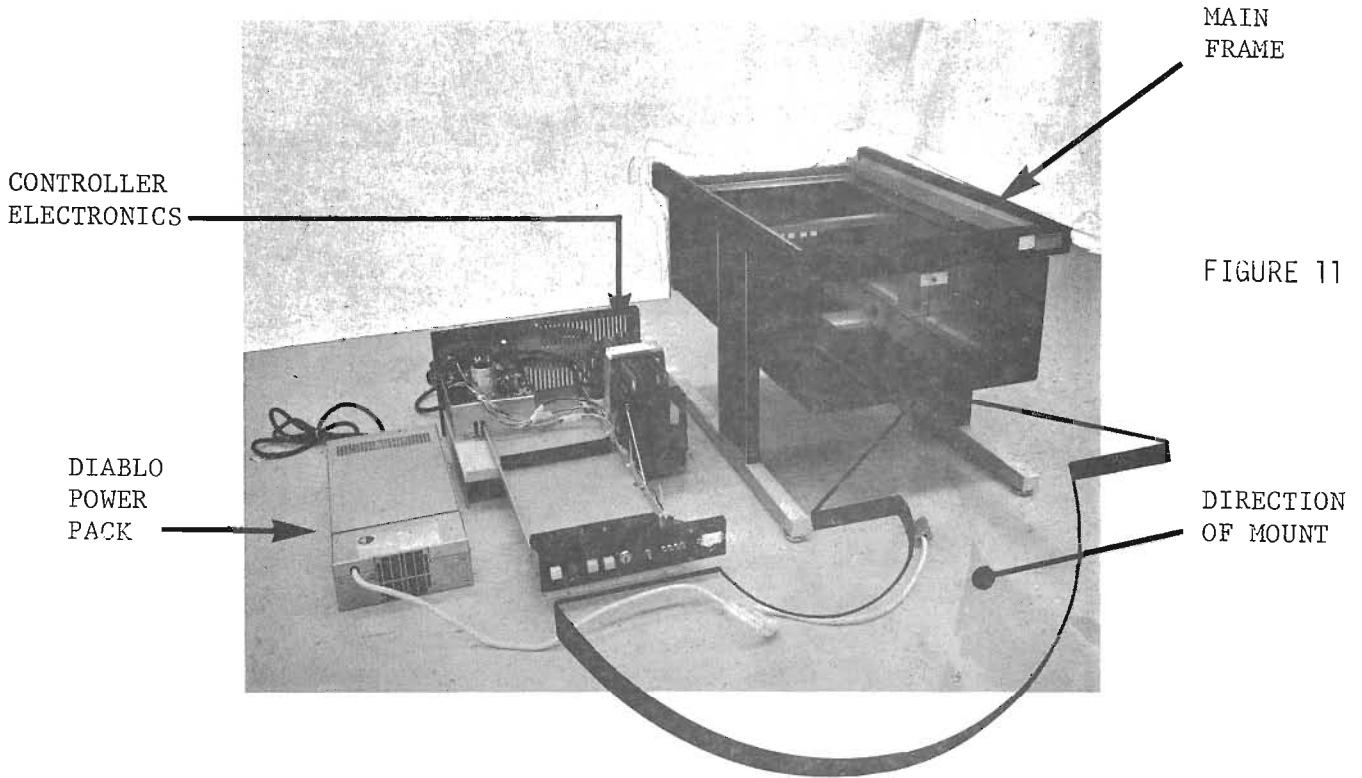

FIGURE 10

110 VAC
WIRES
PROTRUDING
OVER METAL
FLANGE

- 8) Utilizing the power supply mounting bracket found in box #4, mount the Diablo power supply on the controller chassis as shown in Figures 11 and 12.



POWER
SUPPLY
MOUNTING
BRACKET

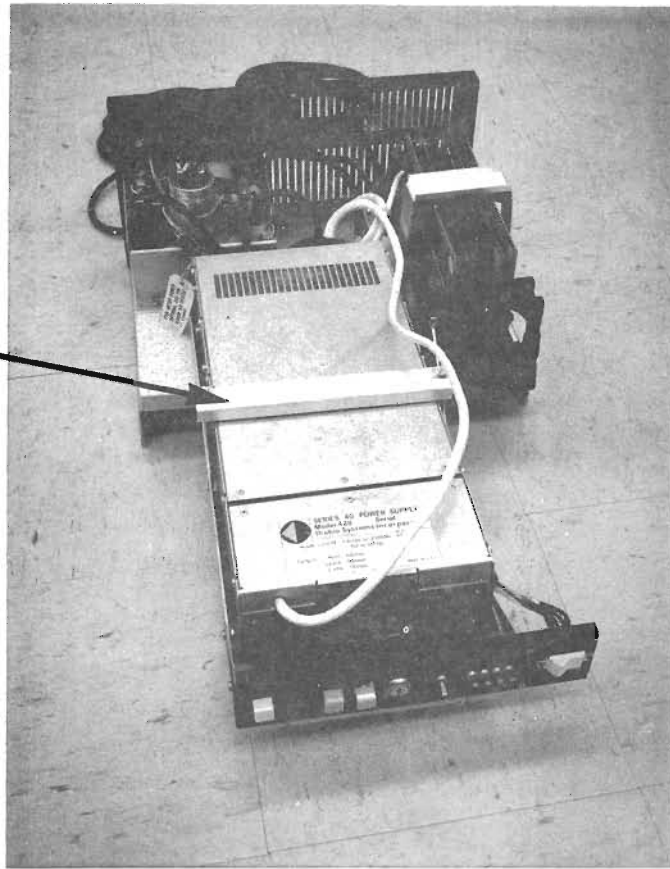

FIGURE 12

- 9) Remove the bolted plywood cover from the upside down disk unit. *Carefully* turn the disk unit over (topside up) and place on top of main frame with the RUN/LOAD rocker switch towards the front of the main frame. The front of the main frame may be recognized by the switch and lamp holes punched in the panel for the controller electronics.

- 10) To install interfacing cables found in box #2, first connect the screw-in Winchester connector to the I/O box at the rear of the disk unit (See Figure 13).

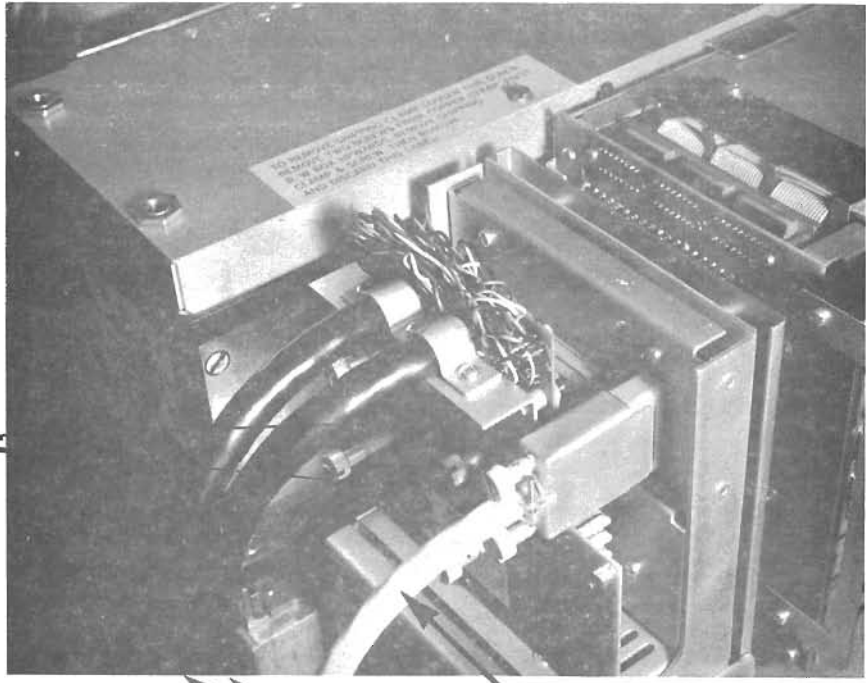

FIGURE 13

SCREW
TYPE
CONNECTOR

REAR APRON
OF
MODEL 30

POWER
SUPPLY
CABLE

INTERFACE
CABLES

- 11) Route the two Amphenol connectors down between the main frame slot, indicated in Figure 14. Connect Amphenol connectors to the controller 6295 PC board as shown in Figures 14 and 15.

POWER
SUPPLY
CABLE

INTERFACE CABLES

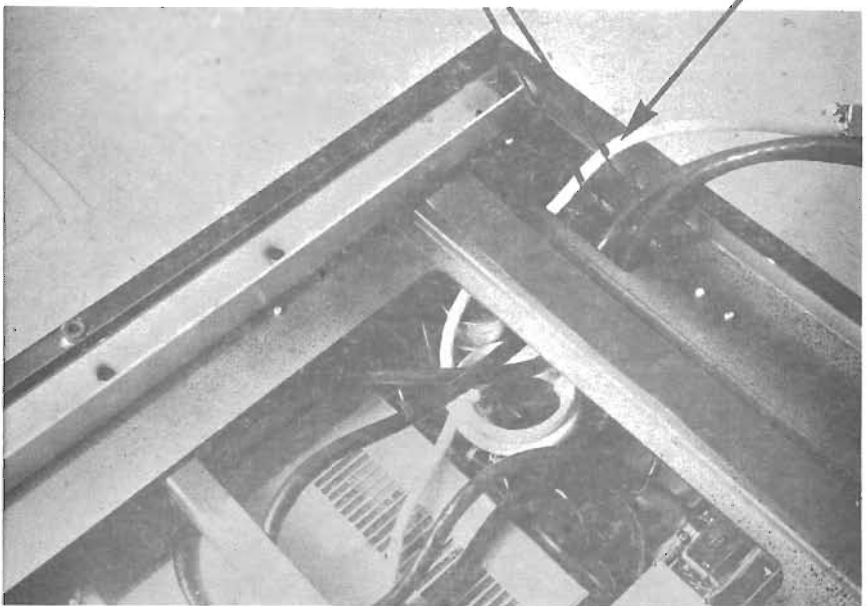

FIGURE 14

CONTROLLER
ELECTRONICS
NOT MOUNTED
AT THIS
POINT

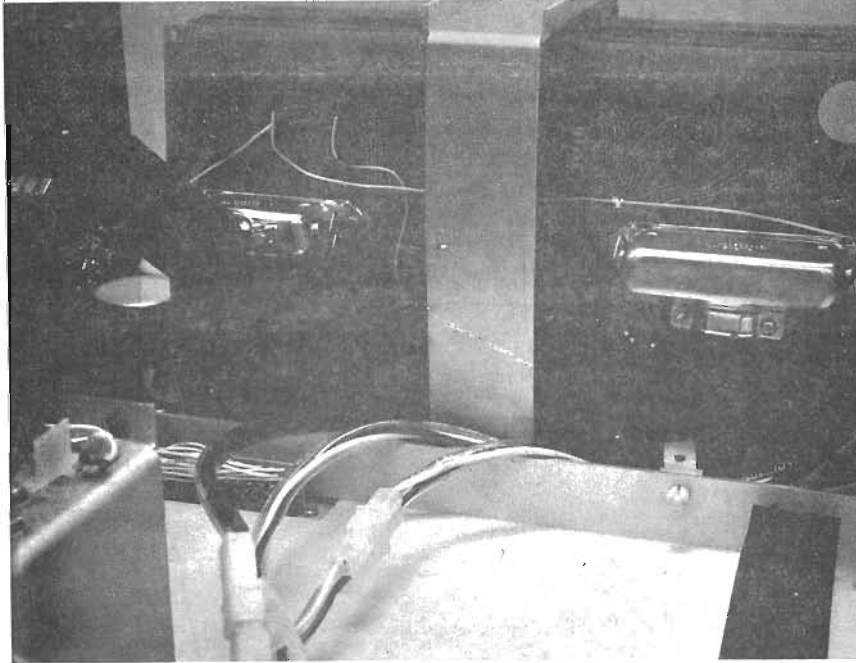

FIGURE 15

INTERFACE CABLE
CONNECTIONS
TO 6295 PC
IN CONTROLLER
ELECTRONICS

- 12) Route the power supply cable up through the same path as the interface cables (Figure 14). Connect the power supply cable (light colored, screw-in type) to the rear of the disk unit as shown in Figure 13.
- 13) Plug the 110 VAC power for the Diablo power supply into the controller chassis AC outlet (adjacent to large electrolytic capacitor).
- 14) Before powering up the unit, the rocker switches on the 6295 board must be set: closed for Model -23 operation, open for calculator only operation. Closed side of rocker switches is noted by a dot or the word ON located on the switch casing.
- 15) Lift the controller and slide it into the main frame, as shown in Figure 11.
- 16) Remove the cover over the Read/Write electronics and the Heat Sink electronics on the disk drive unit. See Figure 16.

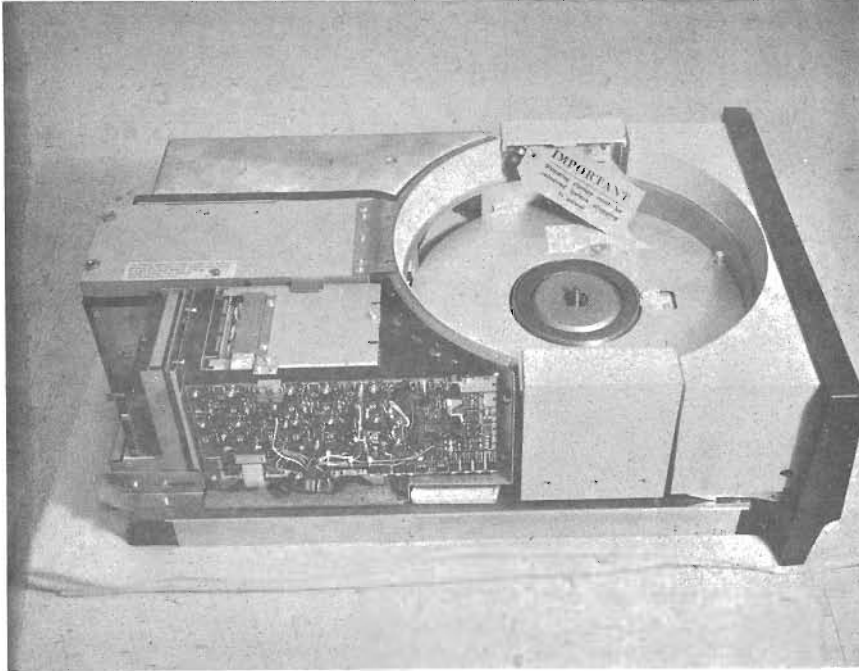

FIGURE 16

MODEL 30;
COVER REMOVED
FROM HEAT SINK
ELECTRONICS
AND READ/WRITE
ELECTRONICS

- 17) Lift up the Read/Write electronics in order to expose the orange colored SHIPPING CLAMP shown in Figure 17.

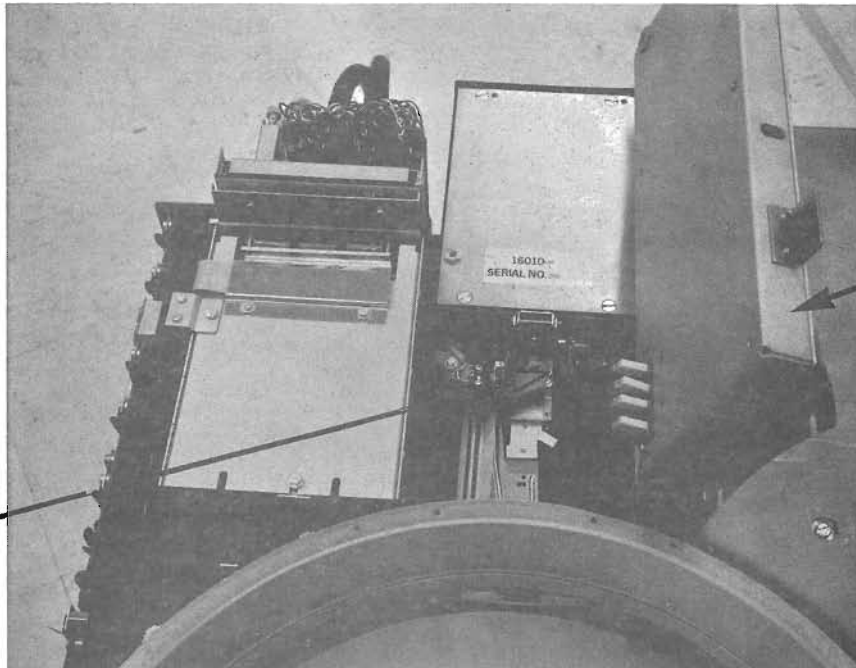

FIGURE 17

LIFT
READ/WRITE
ELECTRONICS

SHIPPING
CLAMP

- 18) Remove the shipping clamp as demonstrated in Figure 18.

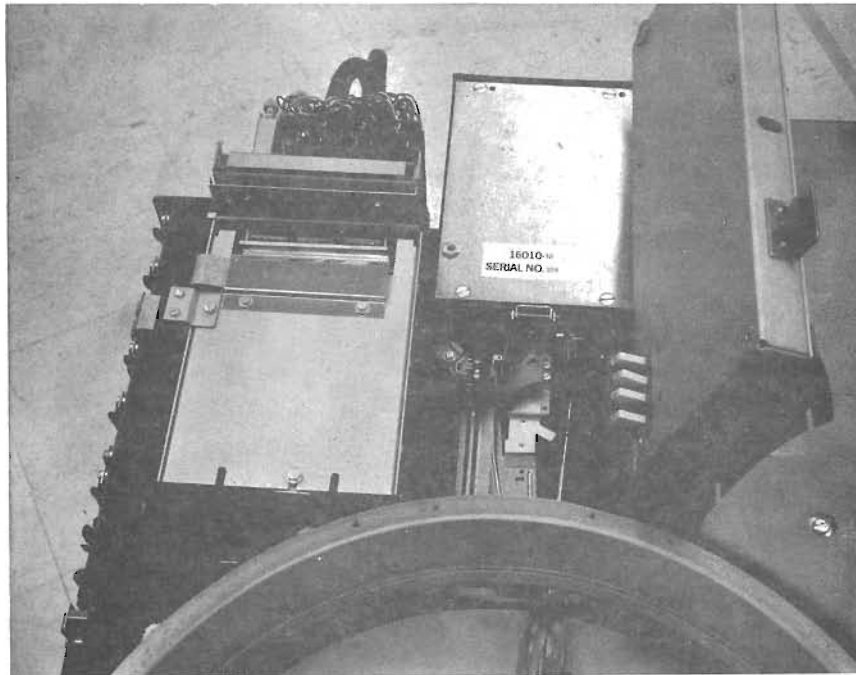

FIGURE 18

LONG SHAFT
SCREWDRIVER

REMOVE
SHIPPING
CLAMP

- 19) Set the Read/Write electronics back into place. Ensure that all PC boards and assemblies are in their *proper* positions and are secure (Both Diablo unit *and* Wang controller).
- 20) Replace the electronics cover.
- 21) Install the beige disk drive cover found in box #4.
- 22) Plug 110 VAC cord for the MODEL 30 disk unit into wall outlet.
- 23) Plug I/O cable from the disk into the calculator I/O jack (turn calculator on).
- 24) Slide controller chassis out far enough to gain access to the 341 voltage regulator PC.

- 25) See paragraph 5.8 of this bulletin for 341 PC voltage checks.
- 26) Slide controller chassis back in place.
- 27) Incorporate the Model 30 into the calculator system as shown by paragraph 3.1, this bulletin.
- 28) Install disk cartridge contained in box #1 per instructions in paragraph 3.3.
- 29) Check format of fixed disk per paragraph 3.5.4 to determine if unit is operational. If unit is operational to this point, proceed to the next step. If the unit fails, format the fixed disk and then check the format. If the unit still fails, perform standard troubleshooting procedures including voltage checks, card substitutions, cable checks and proper connector mating.
- 30) Format the removable disk per paragraph 3.5.1.
- 31) Check the format of the removable disk per paragraph 3.5.2. If the test passes, proceed to the next step. If the test fails, one of the following conditions may exist: removable disk faulty; head is faulty or misaligned; or controller logic faulty.

NOTE:

If it is determined that a head replacement and/or alignment for the removable disk is necessary, the customer must be advised to temporarily use only the fixed disk. Also inform the customer that a head alignment check/adjustment will be performed as soon as possible to insure disk cartridge compatibility. Contact the Regional Office to secure a CE cartridge for the alignment procedure. Once the alignment has been verified, proceed with step 32.

- 32) To check disk interchangeability, first unload the customer's disk and load the service disk per paragraph 3.3.

NOTE:

Do not format the service disk. It has previously been formatted to a working standard.

- 33) When all the above steps have been completed, perform the diagnostic checkout procedure in section 4 of this bulletin; installation is then complete.

3. OPERATION - SOFTWARE

3.1 OPERATING CONFIGURATION

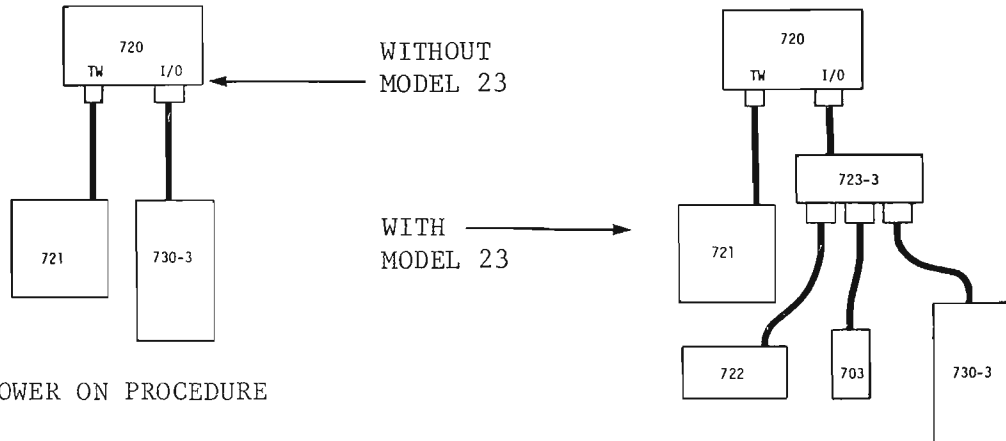

3.2 POWER ON PROCEDURE

- 1) Turn the calculator ON.
- 2) Turn the main power switch (rocker type) on the disk unit to the ON position (Figure 19). Both POWER lights come on (upper and lower panels).

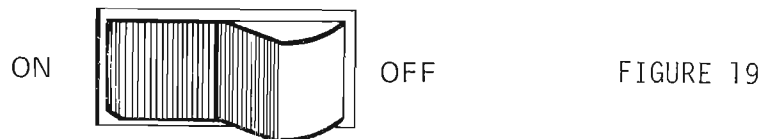

NOTE:

If calculator is ON and disk is OFF, bright digits appear in the X and Y displays.

- 3) Key PRIME on the calculator.
- 4) The LOAD/RUN switch on the disk should be set to LOAD (LOAD and ERROR lights come on).

NOTE:

When the PRIME key is actuated, any disk action is discontinued and the READ/WRITE heads are brought to track 0.

3.3 LOADING AND UNLOADING THE REMOVABLE DISK CARTRIDGE

The 730 has two disks, one Fixed and one Removable disk. The Fixed disk comes installed from the factory and cannot be removed from the 730. The Removable disk, as its name indicates, can be taken out and stored at will by the operator. The following instructions are for changing the Removable disk.

BEFORE LOADING AND UNLOADING

Step 1 - Switch the LOAD/RUN rocker switch on the left front panel of the 730 to the LOAD position (POWER switch must be ON). The LOAD light (white) comes on when the LOAD switch is in position. Wait 30 seconds (Figure 20).

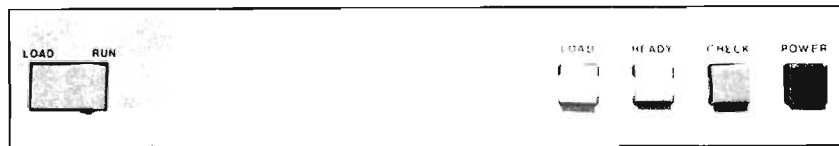

FIGURE
20

Step 2 - Open the cartridge bowl by pulling back the two holding clamps (Figure 21). If these clamps are locked in the closed position, do not force them. They are locked due to an interlock.

(To remove a cartridge, go to Step 6.)



FIGURE
21

LOADING A DISK CARTRIDGE

Step 3 - To load a disk cartridge, press the tab on the handle of the disk cartridge to the left (Figure 22), then raise the cartridge handle (Figure 23). This action separates the dust cover from the disk (Figure 24).

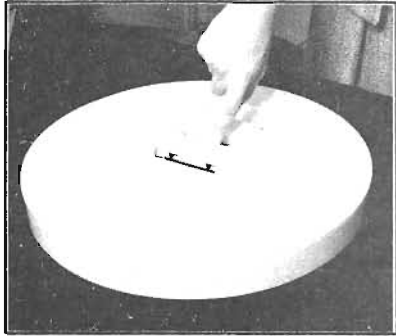

FIGURE 22



FIGURE 23

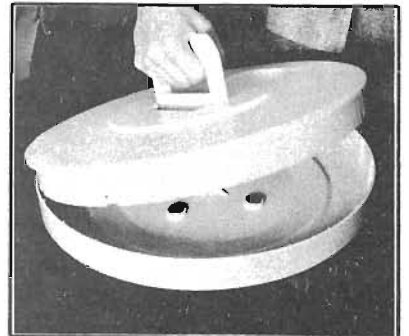

FIGURE 24

Step 4 - Place the disk over the spindle hub in the drive unit. Insure that the cartridge opening for the head entry is located at the rear of the disk bowl (Figure 25).

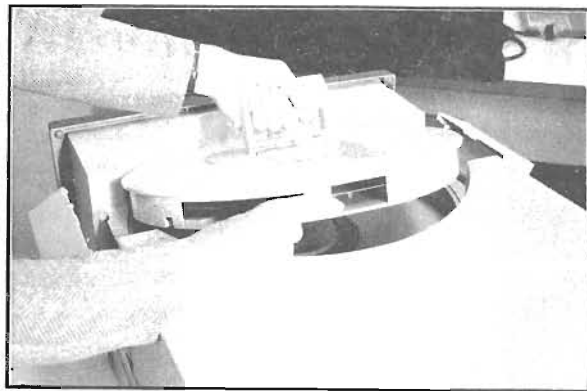

FIGURE
25

When the cartridge is correctly loaded, it sets squarely and does not rotate. Lower the cartridge handle to lock the cartridge to the spindle (Figure 26).

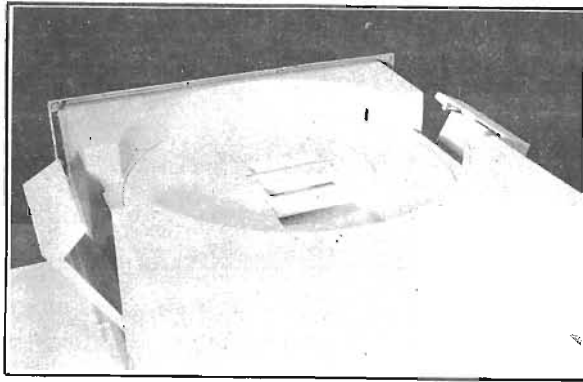

FIGURE
26

Step 5 - Place the dust cover, open end down, on top of the disk and close the two holding clamps (Figure 27).

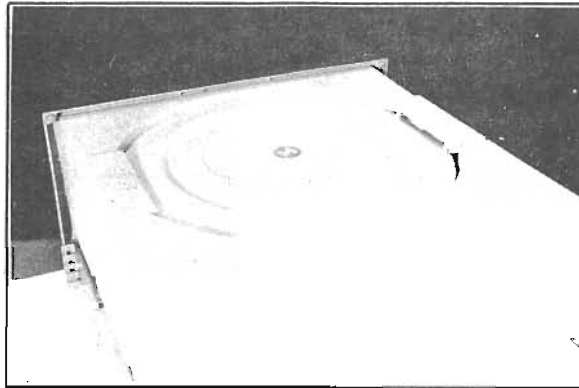

FIGURE
27

UNLOADING A DISK CARTRIDGE

Step 6 - To unload a disk cartridge, be sure the LOAD/RUN switch is on LOAD, with the LOAD light on (waiting 30 seconds). See Figure 20.

Step 7 - Open the holding clamps. If these clamps are locked in the closed position, do not force them. They are locked due to an interlock.

Step 8 - Remove the dust cover (Figure 28). Press the tab on the disk cartridge handle to the left, then raise the handle. This allows the disk to be lifted out of the disk bowl (Figure 29).

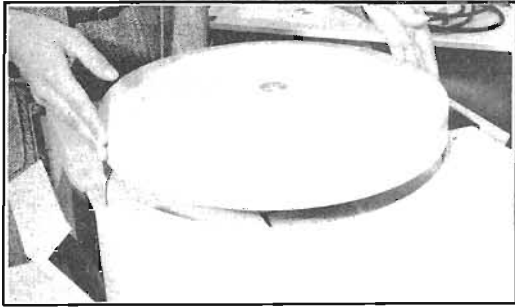

FIGURE 28

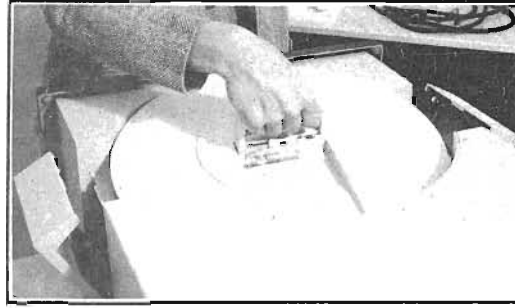

FIGURE 29

Step 9 - Place the dust cover on the bottom of the disk cartridge and lower the handle; this attaches the dust cover to the disk cartridge (Figure 30).



FIGURE
30

3.4 SELECTING THE DISK UNIT

The disk unit is selected from the keyboard of the calculator. Using a 700/720C, a two-step command is necessary to select the disk unit. This command is: GROUP 2, 00XX.

Where: GROUP 2 is a key on the calculator keyboard.

00 means all toggle switches on the calculator are set to zero.

XX means any one of the 16 (00-15) register keys on the calculator keyboard.

NOTE:

The Disk unit cannot be selected unless the Format Lock is off and the unit is in the Run mode with the ready light illuminated.

On the disk unit lower panel there is also a set of toggle switches labeled "GROUP ADDRESS", which must be set to match the XX in the two-step command.



The disk unit *deselects* itself in the following cases:

- 1) Disk unit is turned off.
- 2) Another high speed peripheral device is selected.
- 3) Either disk is formatted.

3.5 FIXED AND REMOVABLE DISK FORMAT CHECKS

Any time a new disk cartridge is loaded into the disk unit, the new disk must be formatted. Also, if an old disk is causing READ/WRITE errors, the problem can sometimes be corrected by reformatting the disk. Each disk, both Fixed and Removable, must be formatted at least once.

Model 30 customers are supplied with a FORMAT CHECK cassette for testing fixed and removable disk format. Operation instructions follow in paragraphs 3.5.2 and 3.5.4.

The Model 30 FORMAT CHECK for fixed and removable disk is a single block diagnostic test. This test will verify sector address integrity. Certain output writer printouts are partially abbreviated:

<u>Abbreviation</u>	<u>Explanation</u>
"P E"	"Program Error"
"D" ("Disk Address(es)"
"(A,B,C,...Z)"	Actual Sector Address(es) Causing Failure - Expressed as <i>number(s)</i>

When initialized, the test proceeds to WRITE and READ data at six sectors per disk revolution. The sectors addressed are eight sector spaces apart. Calculator speed limitations prevent addressing sectors less than eight sector spaces apart, during a single disk revolution. This process is continued until all sectors on the disk under test have been written on and read back to the calculator's memory.

An example of the test addressing pattern follows:

EXAMPLE: FIXED DISK FORMAT CHECK ON TRACKS
0 AND 1 - ADDRESSING SEQUENCE.

<u>Revolution #</u>	<u>Sectors Addressed Per Revolution</u>
1	0 - 8 - 16 - 24 - 32 - 40
2	1 - 9 - 17 - 25 - 33 - 41
3	2 - 10 - 18 - 26 - 34 - 42
4	3 - 11 - 19 - 27 - 35 - 43
5	4 - 12 - 20 - 28 - 36 - 44
6	5 - 13 - 21 - 29 - 37 - 45
7	6 - 14 - 22 - 30 - 38 - 46
8	7 - 15 - 23 - 31 - 39 - 47

Thus, at the end of eight disk revolutions, every sector within tracks 0 and 1 of the fixed disk have been accessed for either a WRITE 256 or a READ 256.

If a sector has been located (completed seek), and a program error light comes on during a WRITE 256 (or a READ 256) at that address, a *WRITE ERROR* and/or *READ ERROR* count is generated by the software and stored in the calculator's memory for later recall.

Five more READ or WRITE attempts are made at the same sector addresses that caused the program error. If a program error condition still exists, the output writer will print:

"P E ON WRITE AT D (A,B,C,...Z)"

No calculator lockout occurs for the above conditions.

The actual data read back to the calculator's memory may not be identical to the original data written on the disk under test. A sample of each data block is compared to the original data. If the comparison is not identical, a *DATA ERROR* is stored in the calculator's memory for later recall.

WRITE, READ, and DATA errors are accumulated in the calculator's memory.

If all sector addresses were successfully *located* for WRITE and READ operations, the output writer will print:

"FORMAT IS OK"

If no WRITE, READ, or DATA errors are accumulated, the program will stop (END).

If any WRITE, READ, or DATA errors were accumulated during the format verification process, the output writer will continue to print the following statements:

(EXAMPLE) "HOWEVER THERE WERE
 15 WRITE ERRORS
 1 READ ERROR
 7 DATA ERRORS"

If the seek operation for any sector address is incomplete (sector address cannot be found) the controller electronics will attempt to seek the sector in question three more times. If the sector still cannot be located, a PROGRAM ERROR on the calculator will turn on, the disk error light will turn on, and the calculator will lock out with blank displays. Should this condition occur, PRIME the calculator, and key SEARCH, 0. A different routine will be executed, causing the output writer to print:

"PROGRAM STOPPED AT D (A)"
"FORMAT OK TO THIS POINT"

If any errors have been accumulated to this point, the output writer will continue to print a "HOWEVER THERE WERE" statement, as previously described. If no errors occurred, the routine will stop.

If, three successive tries with the format check test for either fixed or removable disk still produce calculator lockout and/or error documentation, maintenance is required.

NOTE:

Formatting a disk destroys all information that was previously stored.

3.5.1 *Formatting The Removable Disk*

- 1) The Removable disk must be loaded (POWER switch must be ON).
- 2) Set the LOAD/RUN switch to RUN (Figure 31). Wait for the READY light to come on (about one minute).

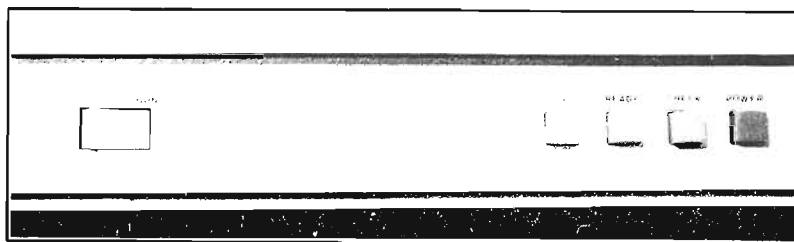

FIGURE
31

- 3) When the READY light is on:
 - (a) Set the REMOVABLE DISK/FIXED DISK switch to REMOVABLE DISK (Figure 32).
 - (b) Turn the FORMAT LOCK key ON (Figure 32).
 - (c) On the calculator, key PRIME.



FIGURE 32

- (d) Push the FORMAT SWITCH (Figure 32).
The FORMAT INDICATOR light comes ON. This indicates that the disk is formatting, which takes 20 seconds.
- (e) When the FORMAT INDICATOR light goes off, check the format.

3.5.2 Removable Disk Format Check - Operating Instructions

NOTE:

This procedure writes over any information stored on the Removable disk. In order to run this program, a 720C calculator must be used and the Disk unit must be selected.

- 1) Turn FORMAT LOCK key OFF, if not already off.
- 2) Load the Removable Disk Format Check Tape (supplied with the 730) into the calculator.
Verify = 9195.
- 3) Key PRIME, GO.

4) Read on the output writer:

"REMOVABLE DISK FORMAT CHECK
THIS ERASES THE REMOVABLE DISK.
KEY DISK TYPE: 1, 2 or 3."

And read in the calculator display:

Y: +.000000000000
X: +

5) Key 1, 2 or 3 (for 730-1, 730-2 or 730-3 respectively), then key GO.

6) Read on the output writer:

"DISK TYPE IS 730-N"

And read in the calculator display:

Y: +.000000000000
X: +N.000000000000

WHERE: N = 1, 2 or 3.

7) Key SEARCH, CLEAR X.

8) There should be a delay of 2, 4 or 6 minutes (for 730-1, 730-2 or 730-3 respectively), then read on the output writer:

"FORMAT IS OK"

The removable disk is ready to use; read in the calculator display:

Y: +.000000000000
X: +.000000000000

- 9) If the calculator locks out (i.e., blank display with error lights on both disk and calculator and no entry):

Key PRIME, SEARCH, 0

- 10) Read on the output writer:

"PROGRAM STOPPED AT D (A,B,C,...Z)
FORMAT IS OK TO THIS POINT"

Z represents the last sector which was addressed.

- 11) Go back to step 3 and check the format again. If the format still fails, format the Removable disk again. After three format/check failures, maintenance is required.

3.5.3 *Formatting The Fixed Disk*

- 1) Set the LOAD/RUN switch to RUN (Figure 31). Wait for the READY light to come on (about one minute).

- 2) When the READY light is on:

- (a) Set the REMOVABLE DISK/FIXED DISK switch to FIXED DISK (Figure 32).

- (b) Turn the FORMAT LOCK key ON (Figure 32).

- (c) On the calculator, key PRIME.

- (d) Push the FORMAT switch (Figure 32).

The FORMAT INDICATOR light comes ON. This indicates that the disk is formatting, which takes 20 seconds.

- (e) When the FORMAT INDICATOR light goes off, check the format.

3.5.4 Fixed Disk Format Check - Operating Instructions

NOTE:

This procedure writes over any information stored on the Fixed Disk. In order to run this program, a 720C calculator must be used and the Disk must be selected.

- 1) Turn FORMAT LOCK key OFF, if not already off.
- 2) Load the Fixed Disk Format Check Tape (supplied with the 730) into the calculator.
Verify = 9143.

3) Key PRIME, GO.

4) Read on the output writer:

```
"FIXED DISK FORMAT CHECK  
THIS ERASES THE FIXED DISK.  
KEY DISK TYPE: 1, 2 OR 3"
```

And read in the calculator display:

```
Y:  +.000000000000  
X:  +
```

- 5) Key 1, 2 or 3 (for 730-1, 730-2 or 730-3 respectively), then key GO.
- 6) Read on the output writer:

```
"DISK TYPE IS 730-N"
```

And read in the calculator display:

Y: +.000000000000

X: +N.000000000000

WHERE: N = 1, 2 or 3.

- 7) Key SEARCH, CLEAR X.
- 8) When this is done, there should be a delay of 2, 4 or 6 minutes (for 730-1, 730-2 or 730-3 respectively), then read on the output writer:

"FORMAT IS OK"

The fixed disk is ready to use; read in the calculator display:

Y: +.000000000000

X: +.000000000000

- 9) If the calculator locks out (i.e., blank display without any flashing):
Key PRIME, SEARCH 0

- 10) Read on the output writer:

"PROGRAM STOPPED AT D (A,B,C,...Z)

Z represents the last sector which was addressed.

- 11) Go back to step 3 and check the format again. If the format still fails, format the Fixed disk again. After three format/check failures, maintenance is required.

NOTE:

After either disk is formatted, the FORMAT LOCK key must be set to OFF, otherwise the disk does not work and the ERROR light on the disk may come on. Formatting a disk causes all data to be lost.

Once a disk is formatted, it never has to be formatted again unless numerous READ/WRITE errors occur.

Once the disk is loaded and formatted, the disk unit can be selected.

If the toggle switches in the 730 match the XX of the select command, the disk is selected; otherwise, the disk is deselected. The user can choose any key from 00 - 15 for XX, as long as the setting does not correspond with the address of another 700/720C peripheral.

3.6 HANDLING AND STORAGE OF THE REMOVABLE DISK CARTRIDGE

The following practices should be observed when handling and storing a disk cartridge:

- 1) The cartridge dust cover should be on the cartridge while it is out of the disk unit. This insures a positive dust seal and immobilizes the disk.
- 2) Cartridges can be stored flat or on edge. Several can be on top of one another, but heavy top loading should be avoided.

3.7 MACHINE INTERLOCKS

The cartridge holding clamps cannot be operated while the heads of the disk or disk cleaning brushes are positioned over the disk surfaces, or when equipment power is OFF.

The disk does not work if the cartridge dust cover is not installed or if the cartridge holding clamps are open.

Initial power ON or LOAD/RUN sequence turns off the interlock circuits to allow normal operation of the disk.

3.8 CHECK LIST

The following steps summarize the necessary procedures to ready either disk for use.

1) Install System

- (a) Plug disk unit connector to calculator.
- (b) Plug disk unit power cord into outlet.
- (c) Plug calculator power cord into outlet.

2) Power On Procedures

- (a) Calculator ON.
- (b) Disk unit ON.

3) Changing Removable Disk Cartridge

- (a) Switch LOAD/RUN switch to LOAD (wait 30 seconds).
- (b) LOAD light (white) ON.
- (c) Open holding clamps on disk unit.
- (d) Separate dust cover from disk cartridge.
- (e) Remove disk cartridge.
- (f) Insert disk cartridge over spindle.
- (g) Replace dust cover.
- (h) Close holding clamps on disk unit.

4) Formatting The Fixed And Removable Disk

- (a) Switch LOAD/RUN switch to RUN (wait 60 seconds for the READY light).
- (b) Turn REMOVABLE DISK/FIXED DISK switch to REMOVABLE DISK (if Fixed disk to FIXED DISK).

- (c) Turn FORMAT LOCK key ON.
- (d) Key PRIME from the calculator.
- (e) Push the FORMAT switch (wait 20 seconds). The FORMAT INDICATOR light then goes off.
- (f) Turn FORMAT Lock key OFF.
- (g) Check the FORMAT.

3.9 READ/WRITE COMMANDS

COMMAND	CODE	FUNCTION
WRITE 256	0814	Transfers a block of 256 steps from calculator to Disk.
READ 256	0806	Transfers a block of 256 steps from the Disk to the calculator.
COMPARE 256	0814	Compares contents of one block on the Disk with one block of 256 steps in the calculator. Same code as WRITE except the number 8,388,608 is added to the Y register to signify to the Disk that this is a COMPARE command.
WRITE 1	0808	Transfers one step from the calculator to the Memory Buffer on the Disk Controller.
READ 1	0800	Transfers one step from the Memory Buffer in the Disk Controller to the calculator.

3.9.1 *WRITE 256*

In order to transfer information from the calculator to the disk, the disk must first be selected. Once the disk is selected, three steps are required to WRITE information:

- 1) Key the disk block address (where writing is to begin on the disk) into the Y register.
- 2) Key the calculator block address (step number where transfer begins) into the X display.
- 3) Enter a WRITE 256 code (0814). This command transfers the 256 step block from the calculator to the disk.

3.9.2 *READ 256*

In order to transfer information from the disk to the calculator's memory, the disk must first be selected. Once the disk is selected, three steps are required to READ information:

- 1) Key the disk block address into the Y display.
- 2) Key the calculator block address (step number where transfer begins) into the X display.
- 3) Enter a READ 256 code (0806). This command transfers the block from the disk to the calculator.

3.9.3 *COMPARE 256*

A special feature of the disk allows comparison of the contents of a block of 256 steps on the disk with the contents of a block in the calculator. If the blocks are not the same, the PROG ERROR light on the 700/720C comes on. This feature is a useful check. It can be used to make sure that a WRITE 256 has executed properly.

To COMPARE blocks, the following steps are used:

- 1) Key the disk block address plus the number 8,388,608 (2^{23}) into the Y register. The addition of this number signals to the disk that this is a COMPARE command as opposed to a WRITE command. For example, if you wish to COMPARE block 1, the address in the Y register is $(1 + 8,388,608)$ or 8,388,609; if you wish to compare block 450, the address in the Y register is $(450 + 8,388,608)$ or 8,389,058.
- 2) Key the calculator block address (step number where transfer begins) into the X register.
- 3) Enter a WRITE code (0814). This command transfers the block from the calculator into a buffer memory in the disk controller. The appropriate disk block is transferred from the disk to another buffer memory. The contents of these buffer memories are compared. If the two buffers compare, control is sent back to the calculator without a PROG ERROR light. If the two buffers do not compare, the PROG ERROR light is turned ON and control is returned to the calculator.

Although there are cases in which the COMPARE command will not detect a transfer error (i.e., if the calculator is dropping bits consistently on WRITES), it does detect a majority of transfer errors.

The primary purpose of the COMPARE 256 command is to allow the programmer to immediately check that data has been correctly written onto the disk. If the block does not compare, try to WRITE and COMPARE at least four times. If an error condition still exists, maintenance is required.

3.9.4 WRITE 1 and READ 1

There is a one-byte memory in the disk controller which adds programming flexibility to the disk.

In order to WRITE a program step (one byte) from the calculator to the one-byte memory in the Wang controller:

- 1) Key any positive integer from 0-999,999,999 ($10^9 - 1$) inclusive into the Y display.
- 2) Key the calculator step number into the X display.
- 3) Key WRITE 1 (0808) command, which causes the indicated step to be sent from the calculator to the 730.

NOTE:

This one-byte memory is in a separate storage location within the disk unit, but is not physically in the disk cartridge. It is part of the disk controller in the lower panel of the disk.

In order to READ the program step from the disk unit's one-byte memory to the calculator:

- 1) Key any positive integer from 0-999,999,999 ($10^9 - 1$) inclusive into the Y display. This number may be different from the number that was used to write one byte.
- 2) Key a step number into the X display; this step will be the destination of the contents of the 730 one-byte memory.
- 3) Key READ 1 (0800) command, which causes the one byte (step) to be sent to the calculator at this indicated step number.

3.10 LEGAL SECTOR (BLOCK) ADDRESSES

FIXED DISK			REMOVABLE DISK		
TRACK #	ADDRESS	BOTTOM/TOP SURFACE	TRACK #	ADDRESS	BOTTOM/TOP SURFACE
0	0-23	B	0	1,048,576-1,048,599	B
1	24-47	T	1	1,048,600-1,048,623	T
2	48-71	B	2	1,048,624-1,048,647	B
3	72-95	T	3	1,048,648-1,048,671	T
4	96-119	B	4	1,048,672-1,048,695	B
5	120-143	T	5	1,048,696-1,048,719	T
6	144-167	B	6	1,048,720-1,048,743	B
7	168-191	T	7	1,048,744-1,048,767	T
8	192-215	B	8	1,048,768-1,048,791	B
↓	↓		↓	↓	
<u>97</u>	<u>2328-2351</u>	T	<u>97</u>	<u>1,050,904-1,050,927</u>	T
98	2352-2375	B	98	1,050,928-1,050,951	B
99	2376-2399	T	99	1,050,952-1,050,975	T
100	2400-2423	B	100	1,050,976-1,050,999	B
101	2424-2447	T	101	1,051,000-1,051,023	T
102	2448-2471	B	102	1,051,024-1,051,047	B
103	2472-2495	T	103	1,051,048-1,051,071	T
104	2496-2519	B	104	1,051,072-1,051,095	B
↓	↓		↓	↓	
<u>198</u>	<u>4752-4775</u>	B	<u>198</u>	<u>1,053,328-1,053,351</u>	B
199	4776-4799	T	199	1,053,352-1,053,375	T
200	4800-4823	B	200	1,053,376-1,053,399	B
201	4824-4847	T	201	1,053,400-1,053,423	T
202	4848-4871	B	202	1,053,424-1,053,447	B
↓	↓		↓	↓	
<u>299</u>	<u>7176-7199</u>	T	<u>299</u>	<u>1,055,752-1,055,775</u>	T
300	7200-7223	B	300	1,055,776-1,055,799	B
301	7224-7247	T	301	1,055,800-1,055,823	T
↓	↓		↓	↓	
<u>399</u>	<u>9576-9599</u>	T	<u>399</u>	<u>1,058,152-1,058,175</u>	T

3.11 INDICATOR LIGHTS AND SWITCHES

There are several indicator lights on the 730 and on the calculator. The purpose of these lights is to indicate what condition the system is in, and if an error has occurred.

3.11.1 Upper Panel Lights and Switches (Figure 33)

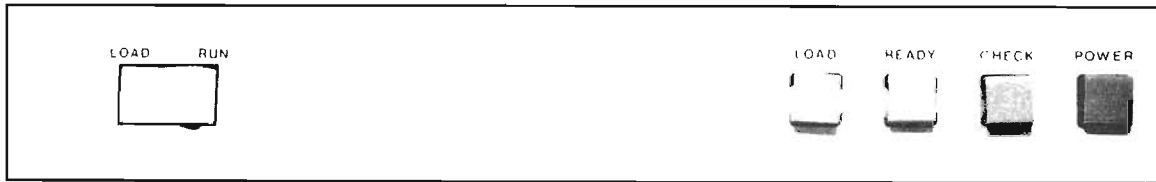

FIGURE 33

LOAD/RUN Switch Set To RUN

After selecting the RUN mode for the disk drive, the READY light should come on in 60 seconds and the ERROR light, lower panel, should go off.

NOTE:

If the FORMAT LOCK key is ON, key PRIME on the calculator to turn OFF the ERROR light.

LOAD/RUN Switch Set To LOAD

After selecting the LOAD mode for the disk drive, the ERROR light comes on immediately and the LOAD light should come on in 10 seconds.

The LOAD light, when ON, indicates that the disk is in the LOAD mode. This means that the REMOVABLE disk can be changed.

CAUTION:

NEVER LEAVE THE LOAD/RUN SWITCH IN THE LOAD POSITION FOR MORE THAN 15 MINUTES AS THE DISK UNIT COULD OVERHEAT.

The LOAD light, when OFF, indicates that the REMOVABLE disk cannot be changed and that the disk drive is either in RUN mode or between LOAD and RUN.

The READY light, when ON, indicates that the disk drive is in RUN mode and ready to use. When the READY light is OFF, the disk is in LOAD mode, or is between RUN and LOAD.

CHECK LIGHT - This light is OFF when the disk drive operates properly. The light is ON when the disk drive is *not* working properly.

POWER LIGHT - The POWER light is ON whenever the ON/OFF rocker switch on the lower panel is ON. The POWER light is OFF whenever the ON/OFF rocker switch on the lower panel is OFF.

3.11.2 Lower Panel Lights and Switches (Figure 34)

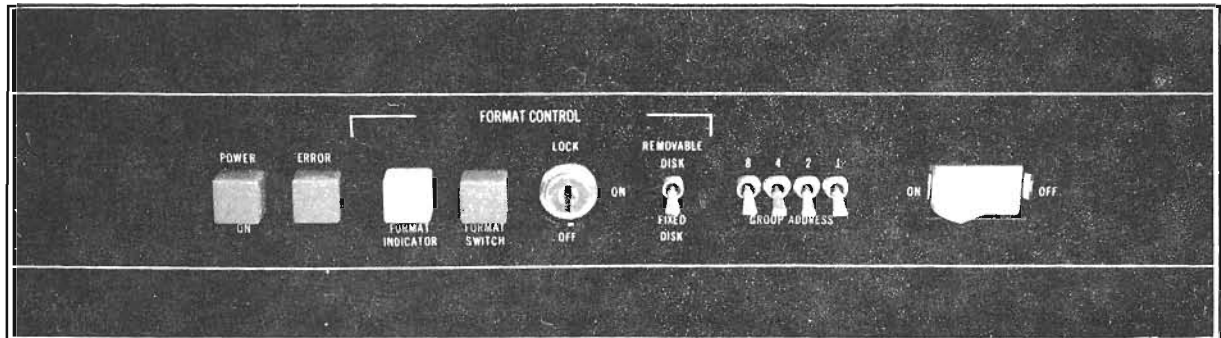

FIGURE 34

- 1) POWER LIGHT - The POWER light is ON whenever the ON/OFF rocker switch is ON. The POWER light is OFF whenever the ON/OFF rocker switch is OFF.
- 2) ERROR LIGHT - The disk ERROR light has three conditions: OFF, ON, and FLASHING.

The disk ERROR light is OFF when legal transfer commands are being successfully executed. The disk ERROR light may be turned OFF by either keying PRIME on the calculator, or by the successful completion of a legal transfer command.

The disk ERROR light is turned ON when an error associated with the disk has occurred.

NOTE:

When the disk ERROR light comes on, the PROG ERROR light on the calculator is also turned on.

- (a) On a READ 256, an error is generated if the CRC comparison indicates a disk malfunction (trying to read a block that has never been written, or indicating that information has not been transferred correctly).
- (b) On a READ 256, an error is generated if the disk unit cannot find the block addressed. This will lock out the calculator. The disk unit will attempt to READ 256 four times before turning on the disk ERROR light.
- (c) On a WRITE 256, an error is generated if the disk unit cannot find the block addressed. This locks out the calculator. The disk unit will attempt to WRITE 256 four times before it turns on the disk ERROR light.
- (d) On a COMPARE 256, an error is generated if the CRC comparison indicates a disk malfunction (trying to compare a block that has never been written or has been improperly written).
- (e) On a COMPARE 256, an error is generated if the disk cannot find the block addressed. This will lock out the calculator.
- (f) On a COMPARE 256, an error is generated if the block read from the disk is not equivalent to the block written from the calculator.

The disk unit executes four COMPARE 256 for errors [(d) and (e)]
However, just one attempt is made when unequal blocks are encountered
[(f)].

There are no cases in which a READ 1 or a WRITE 1 turns on the disk
ERROR light.

A FLASHING ERROR light indicates an operator error. It is accompanied
by a lockout. It does not turn on the PROG ERROR light. If the PROG
ERROR light is ON, it was turned ON by a previous command. These are
some of the possible operator errors:

- (a) On a READ 256 an error is generated if the Y value (the disk address)
is outside the following legal ranges:

*Y must be ≥ 0 , but \leq MAX for fixed disk.

Y must be ≥ 1048576 , but \leq MAX + 1048576 for removable disk.

WHERE: MAX = 9599, 4799 or 2399 for 730-3, 2 or 1 respectively.

- (b) On a WRITE 256 or COMPARE 256 (any 0814 command), an error is
generated if Y value (the disk address) is outside the
following legal ranges:

Y must be ≥ 0 , but \leq MAX for fixed disk (WRITE 256).

Y must be ≥ 1048576 , but \leq MAX + 1048576 for removable
disk (WRITE 256).

Y must be ≥ 8388608 , but \leq MAX + 8388608 for fixed
disk (COMPARE 256).

Y must be $\geq 8388608 + 1408576$, but \leq MAX + 1048576 + 8388608
for removable disk (COMPARE 256).

WHERE: MAX = 9599, 4799 or 2399 for 730-3, 2 or 1 respectively.

*The symbol \geq means "greater than or equal to"; the symbol \leq means
"less than or equal to".

(c) On any transfer command which is illegal.

Illegal transfer commands to the disk are:

0801	READ 8
0802	READ 16
0803	READ 32
0804	READ 64
0805	READ 128
0809	WRITE 8
0810	WRITE 16
0811	WRITE 32
0812	WRITE 64
0813	WRITE 128

NOTE:

The above commands are legal for the calculator when the disk is *not* selected.

Legal transfer commands to the disk are:

0800	READ 1
0806	READ 256
0808	WRITE 1
0814	WRITE 256 or COMPARE 256

There are no cases in which a READ 1 or WRITE 1 generates a FLASHING ERROR light.

3) FORMAT INDICATOR LIGHT - The FORMAT INDICATOR light has three conditions: OFF, ON or FLASHING.

(a) OFF - The FORMAT INDICATOR light is OFF when the disk unit is not running the format sequence.

- (b) ON - The FORMAT INDICATOR light is ON while the format sequence is running. The only way to start the format sequence is by using the FORMAT LOCK key and the FORMAT SWITCH. When the format sequence is finished, the FORMAT INDICATOR light will go OFF. If the light should ever come ON after any READ, WRITE or COMPARE command, maintenance is required.
- (c) FLASHING - The FORMAT INDICATOR FLASHES when the operator has attempted a READ 256, WRITE 256 or COMPARE 256 while the FORMAT LOCK key is ON. This is accompanied by a calculator lock out.
- 4) FORMAT SWITCH - When pushed, the FORMAT switch starts the format sequence (only if the FORMAT LOCK key is ON). If the FORMAT LOCK key is OFF, the FORMAT SWITCH is disengaged.
- 5) FORMAT LOCK ON/OFF KEY - When ON, format, but do not READ 256, WRITE 256, or COMPARE 256. READ 1 and WRITE 1 is permissible. When OFF, no format. The FORMAT SWITCH is disengaged. Perform all legal transfer commands.
- 6) REMOVABLE DISK/FIXED DISK SWITCH - This switch determines which disk (FIXED or REMOVABLE) is to be formatted when keying the FORMAT SWITCH (4) above).
- 7) GROUP SWITCHES - These four switches determine the Group 2 address code selected for the 730 disk drive.
- 8) ON/OFF SWITCH - When ON, the POWER and the POWER ON lights should be ON. When OFF, then all disk panel lights should be OFF, and the disk drive should be stopped.

3.11.3 *Calculator Program Error Light*

- 1) OFF - Under normal conditions the PROG ERROR light is OFF.

2) ON - Any illegal calculator command illuminates the PROG ERROR light. Only those illegal operations associated with memory transfer are listed below. (See the 720 Reference Manual #700-0342 for a detailed description of illegal calculator commands.)

(a) The PROG ERROR light illuminates during an attempted *legal* transfer when either or both of the following numbers are contained in the X and Y displays:

X - ≥ 1729 or a negative number (for 256 bytes).

X - ≥ 1984 or a negative number (for 1 byte).

Y - $\geq (10^9)$ or a negative number.

(b) The PROG ERROR light illuminates anytime the disk error light illuminates.

4. 730 DATA DIAGNOSTIC

NOTE:

All calculator diagnostics should be run first with the Model 30 *off-line*.

4.1 DESCRIPTION

MINIMUM EQUIPMENT NEEDED:

720C Calculator

730-1 Disk Drive

701, 702, 711, 721 Output Writer

The Data Diagnostic begins by checking the one byte transfer command. The main test then begins on the bottom disk, and after each address has been checked in ascending order, it advances to the top disk. The test performs the following functions at each address:

- 1) The calculator writes a data pattern from a primary 16 register buffer.
- 2) The calculator performs a Write Compare immediately to verify that the transfer was made correctly from the primary buffer.
- 3) The calculator reads the information just written into a secondary 16 register buffer.
- 4) The calculator performs a Write Compare immediately with the secondary buffer to verify that the information was read correctly.

When a failure occurs, several conclusions can be drawn from the above statements using the diagnostic printouts.

- 1) If an error occurs on a WRITE command, a "W" with the address that failed will be printed. This indicates that either the controller or the disk drive is faulty.

- 2) If an error occurs on a Write Compare after a write, a "WCW" with the address that failed will be printed. This indicates that: the data was not written correctly; the disk drive cannot read; or the Compare instruction does not work.
- 3) If an error occurs on a READ command, an "R" with the address that failed will be printed. This indicates that the CRC code developed during the 256 byte READ did not compare identically to the CRC code recorded on the disk.
- 4) If an error occurs on a Write Compare after a read, a "WCR" with the address that failed will be printed. This indicates that data was lost on the preceding READ.

There are many more conclusions that can be drawn using the printouts, especially errors that form patterns, so that troubleshooting with this diagnostic can become simplified.

The data diagnostic should be used to check the disk drive under the worst case data patterns. These consist of 00 00, 05 05, 10 10 and 15 15. When the program is loaded into the calculator, these data patterns are stored in the following registers:

05 05 - Register 247
10 10 - Register 245
15 15 - Register 246

Whenever any other pattern is desired, including all zeroes, key it into the X display at the appropriate time.

The minimum time for one complete pass is as follows:

730-1 12 minutes
730-2 24 minutes
730-3 48 minutes

after which "PASS# X" will be printed on the output writer.

After a combination of 25 Read or Write errors, or 25 Write Compare errors are generated, the program terminates.

4.2 DIAGNOSTIC OPERATING INSTRUCTIONS

- 1) Set address switches to 0000 on 730.
- 2) PRIME, LOAD PROGRAM, VERIFY 8259 on 720 calculator.
- 3) PRIME, GO (Printout is "730 DATA DIAGNOSTIC").
- 4) Key unit capacity 1, 2, or 3. Key GO. (Printout on same line, "730-X").
- 5) The number 96 appears in both displays. Key in desired pattern. Key GO. (Before keying GO, insure that 96 is in the Y display).
- 6) Test will continue unless a maximum number of errors (=25) are generated.

4.3 ADDITIONAL PROGRAM INFORMATION

4.3.1 *Changing Data Pattern*

During testing, if a different data pattern is desired, key STEP, SEARCH e^x (96 appears in X and Y displays). Key new data pattern in the X display insuring that 96 remains in Y before depressing GO. Key GO. This procedure restarts the program with a different data pattern.

4.3.2 *Top Disk Test Only*

If desired, this data diagnostic can be adjusted to test only the top (removable) disk. With the program loaded into the 720 with the verify of 8259, LEARN MODE, SET PC, 0277. Key into memory, SEARCH, 5.

RUN MODE, VERIFY 8244. Perform steps 3 - 6 of section 4.2, DIAGNOSTIC OPERATING INSTRUCTIONS. To restore the program to its original state, insert GO, GO in place of SEARCH, 5 (steps 0277 and 0278).

4.3.3 *Bottom Disk Test Only*

The data diagnostic can also be adjusted to test only the *bottom* (fixed) disk. With the program loaded in the 720 (Verify = 8259), LEARN MODE, SET PC, 0328. Key into memory: SEARCH, $|x|$ (absolute value of x). RUN MODE, VERIFY 8245. Perform steps 3 - 6 of section 4.2, DIAGNOSTIC OPERATING INSTRUCTIONS. To restore the program to its original state, insert GO, GO in place of SEARCH, $|x|$ (step 0328 and 0329).

4.3.4 *Registers Used*

Register 000 - Model of unit under test.

Register 008 - Read/Write error accumulator.

Register 040 - Pass number.

Register 045 - Write Compare error accumulator.

Register 050 - Maximum address of unit under test.

Register 060 - Address accumulator.

Registers 064 - 095 (steps 1471 - 1216) - 256 bytes read into calculator (secondary buffer).

Registers 096 - 127 (steps 1215 - 960) - 256 bytes written on the disk (primary buffer).

4.3.5 Typical Diagnostic Outputs

		730 DATA DIAGNOSTIC	730- 1
DATA PATTERN	→	.111188888890ex 23	
12 MINUTES	→	PASS# 1	
PER PASS	→	PASS# 2	
730-1	→	PASS# 3	
		PASS# 4	
		PASS# 5	
		PASS# 6	
		PASS# 7	

		730 DATA DIAGNOSTIC	730- 1
15 15 DATA PATTERN	→	0. ex0	
		PASS# 1	
		PASS# 2	
		PASS# 3	
ERROR AT		PASS# 4	
ADDRESS 2244	→	WCR 2244	
		PASS# 5	
		PASS# 6	
ERROR AT		PASS# 7	
ADDRESS 2272	→	WCW 2272	

5. MAINTENANCE PROCEDURES

5.1 GENERAL INFORMATION

The MODEL 30 is designed to reduce preventive maintenance and repair. The design has resulted in the removal of potentiometers, belts, pulleys, and other mechanisms normally requiring field adjustment. The only exceptions are the DC supply adjustments for the controller. Spindle speed and head position are controlled electronically.

The electronic detenting of the MODEL 30 holds the head cartridge. Do not attempt to move the head location when power is applied until the servomechanism is released by depressing the Servo Release Switch (Ref: DIABLO MAINTENANCE MANUAL).

5.2 PREVENTIVE MAINTENANCE

The preventive maintenance of the MODEL 30 is comprised of visual inspection and cleaning.

Preventive maintenance procedures, when operating in a normal office environment on a one-shift basis, are to be performed at 1000 operating hour intervals; a dirty environment or a high incident of cartridge loading may dictate increased preventive maintenance. The spindle and head positioner motors do not require preventive maintenance action and should not be disassembled to be inspected. The Table (next page) indicates the area that should receive preventive maintenance and the action to be performed.

PREVENTIVE MAINTENANCE ACTION

<u>ASSEMBLY:</u>	<u>ACTION:</u>	<u>FREQUENCY</u>
Read/Write Heads	Clean and inspect for scratches and build-up of oxide.	Monthly
Head Carriage	Clean and inspect.	↓ Semi-Annual
Spindle Assembly	Clean and inspect the magnetic ring. Magnetic particles may be removed using adhesive tape.	↓
Base Plate & Covers	Clean and inspect for loose hardware.	↓
Air Filter	Replace	↓

5.3 PREVENTIVE MAINTENANCE PROCEDURES - SEE DIABLO MAINTENANCE MANUAL

5.4 CIRCUIT BOARDS - DIABLO (SEE DIABLO MAINTENANCE MANUAL)

CAUTION:

Never remove or install circuit board while power is applied.

The electronic card cage should be pivoted outward to gain access to the circuit boards. The card cage is held in place with a one screw spring steel latch. An easy method to remove a board is illustrated in the DIABLO MAINTENANCE MANUAL.

Circuit board nomenclature is clearly marked on the component side of each board.

Anytime the electronic card cage is pivoted outward and power is applied to the MODEL 30, a fan (WLI #400-1003 for example) must be placed atop the card cage with airflow directed downward, in order to reduce heat build up. If this is not done, the MODEL 30 will begin malfunctioning after twenty minutes.

5.5 ALIGNMENTS

5.5.1 Head Alignments/Replacements

The four read/write heads in the MODEL 30 are numbered as follows:

<u>HEAD #</u>	<u>DIABLO #</u>	<u>LOCATION</u>
01	16272-01	Removable disk, bottom surface
02	16272-02	Removable disk, top surface
03	16272-03	Fixed disk, bottom surface
04	16272-04	Fixed disk, top surface

If it is determined that heads #03 or #04 must be replaced and/or aligned, follow the procedure outlined in the Diablo Maintenance Manual. For replacements and/or alignments of heads #01 or #02, the procedure outlined below must be followed.

- 1) Calculator OFF; Disk OFF; no cartridge loaded; covers removed from Disk unit, exposing electronics modules. Ensure that the 6298 controller PC has the proper ICs for 730-2 operation (See paragraph 5.7, this bulletin). If necessary, install the proper 6298 board for 730-2 operation.
- 2) Loosen screws A and B (Figure 35) which secure the card cage and read/write electronics.
- 3) Lift the read/write electronics module as shown in Figure 36.
- 4) Move card cage to the head alignment position as follows:
 - (a) Hold the spring latch (Figures 35, 36) away from the card cage.
 - (b) Lift the card cage upwards, then outwards, to allow the cage hinges to open.

FIGURE 35

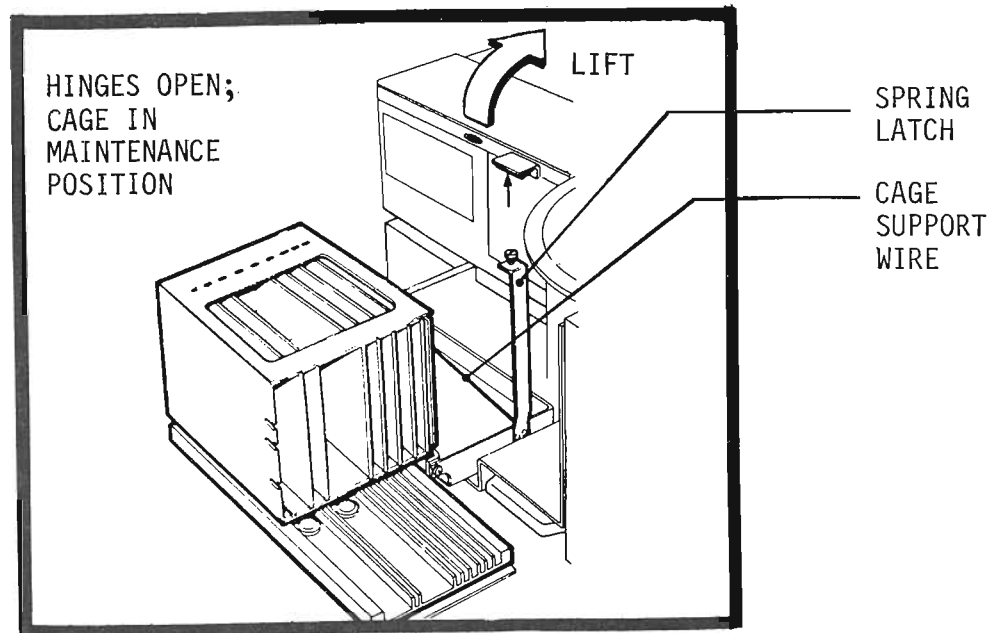
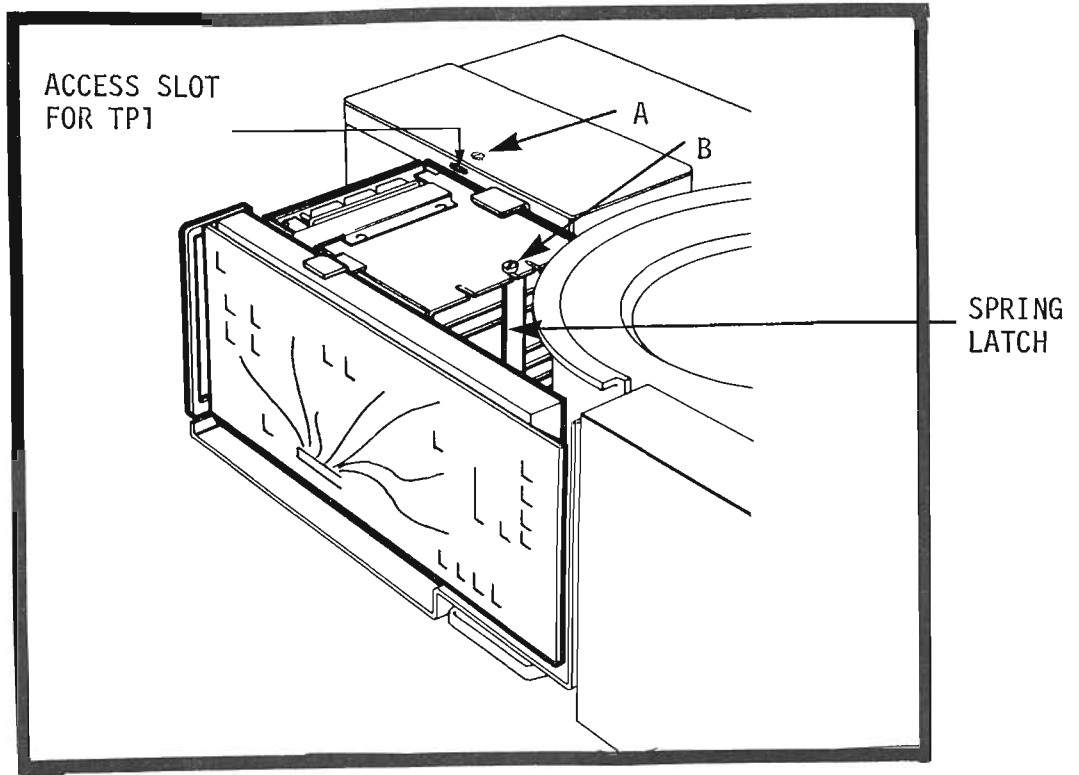
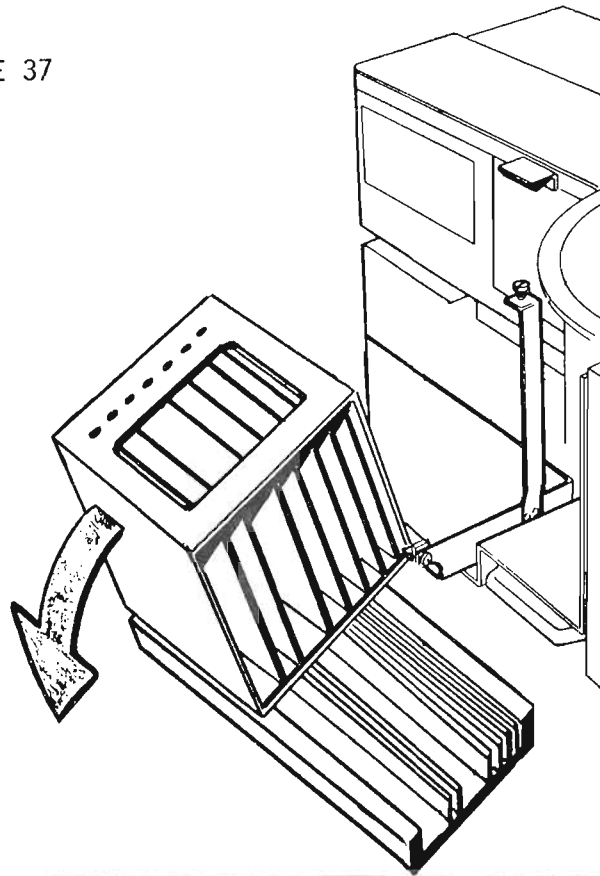

FIGURE 36

FIGURE 37



CAGE SUPPORT
WIRE DISCON-
NECTED; MOVE
CAGE TO A
FULL TILT
POSITION

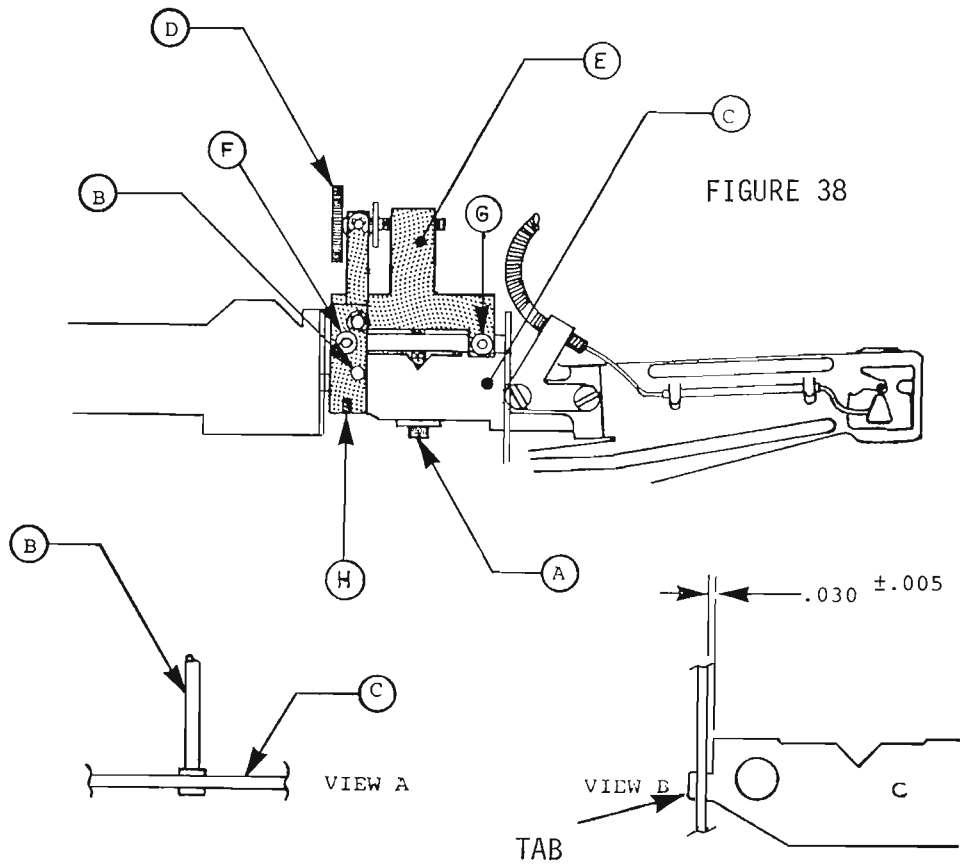

FIGURE 38

- (c) Tilt card cage into the maintenance position. (Figure 36)
 - (d) Holding card cage, disconnect the cage support wire. (Figure 36)
 - (e) Ease the card cage down, so that it rests on the main frame, in a full tilt position (Figure 37). Read/Write heads are now accessible.
- 5) RUN/LOAD rocker switch to LOAD.
 - 6) Disk power ON.
 - 7) RUN/LOAD to RUN.
 - 8) Depress cartridge detect sensor at front of bowl. When spindle rotation is at maximum speed, and the brush cycle has been completed, a click will be heard as the heads load. READY light should come on at this time.
 - 9) If either head #01 or #02 require alignment, go to step 10; if #01 or #02 require replacement, proceed as follows:
 - (a) Loosen allen screw A ONLY 1/2 TURN. (Figure 38)
 - (b) RUN/LOAD to LOAD.
 - (c) When LOAD light comes on, switch disk power OFF.
 - (d) When unit is OFF, the head carriage will have retracted. Move the carriage forward by manually releasing the carriage interlock (Figure 39) by pushing the indicated link in the direction of the arrow; simultaneously move the carriage towards the bowl.
 - (e) Using a pair of hemostats, compress and remove the head loading spring for the defective head. Leave hemostats clamped on compressed spring.

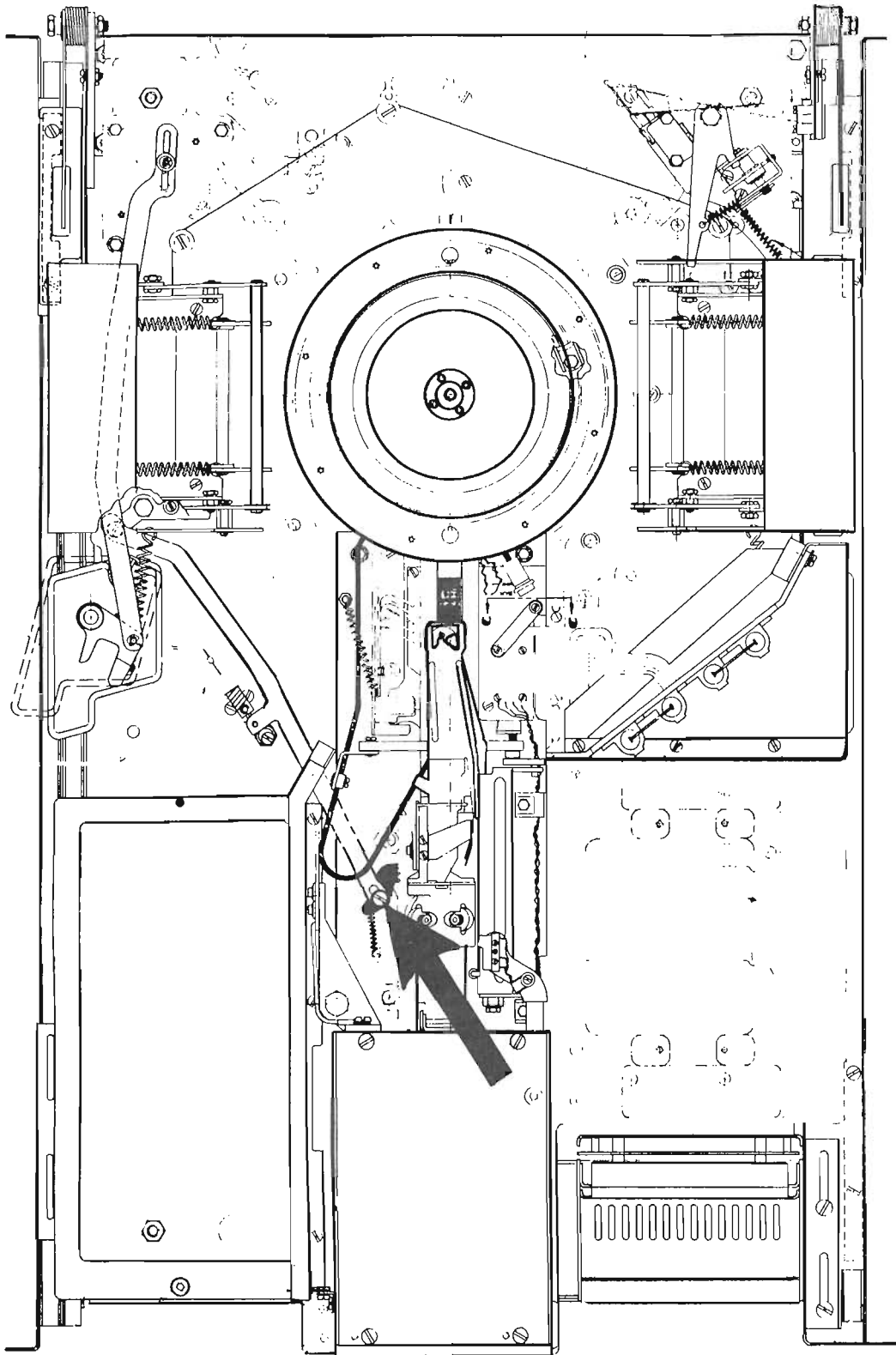

FIGURE 39 - CARRIAGE INTERLOCK

- (f) Loosen the three plastic wire clamps and remove the head wires and connector of the defective head.
 - (g) Remove defective head by moving it towards the bowl.
 - (h) Install new head so that the tab on the end of the head mounting plate (C, Figure 38, view B) sits flush in the guide slot.
 - (i) Reinstall head loading spring using hemostats.
 - (j) Install new head wires and head connector.
 - (k) Tighten allen screw A on new head. (Figure 38)
- 10) If a head replacement was performed, and with disk power still OFF, proceed with step 11. If head replacement was NOT performed, switch to LOAD. When LOAD light comes on, turn disk power OFF, then proceed with step 11.
 - 11) Install head alignment tool E as shown in Figure 38 and tighten thumbscrews F and G onto head mounting plate C of head #02.
 - 12) Turn knurled knob D in Figure 38 until the large end of pin B drops down through the hole in the mounting plate C of head #02.
 - 13) Again turn knob D until the large end of pin B engages the hole in mounting plate C of head #01.
 - 14) Rotate pin B so that the flat portion of its shaft can be engaged by set screw H.
 - 15) Tighten set screw H.

- 16) RUN/LOAD to LOAD.
- 17) When LOAD light comes on, load the CE cartridge (alignment disk).
- 18) Do NOT format.
- 19) RUN/LOAD to RUN.
- 20) Allow disk to run for twenty minutes after the READY light comes on, in order to reach a stable running temperature.
- 21) Attach oscilloscope ground to Model 30 chassis ground.
- 22) Trigger oscilloscope externally, with negative slope at pin 11 of the SR (sensor) PC board.
- 23) Horizontal amplifier to 5 ms/div.
- 24) Vertical amplifier to 0.2 v/div.
- 25) Attach vertical amplifier probe to TP1, which is accessible through a slot in the side of the read/write module casing. See Figures 35 or 36.
- 26) Turn calculator ON.
- 27) Ensure Format lock key is OFF.
- 28) Select disk; Group II, 00XX.
- 29) Read 256 at sector address 1052080 in order to read the bottom surface of the CE cartridge, at cylinder 73. Ignore error lights.

- 30) Turn knurled knob D until the signal is in proper adjustment (equal length lobes) as in Figure 42. Figures 40 and 41 are *incorrect* adjustments.
- 31) Using a torque screwdriver, tighten screw A (Figure 38) to 65 inch-ounces. The signal may change after tightening screw A. Allow for this during adjustment.
- 32) READ 256 at sector address 1052104 in order to read the *top* surface of the CE cartridge, at cylinder 73. Ignore error lights.
- 33) Loosen set screw H. (Figure 38)
- 34) Lift pin B until the large end of that pin engages the hole in the mounting bracket C of head #01. Adjust knurled knob D, if necessary, to accomplish the above result.
- 35) Tighten set screw H onto the flat portion pin B's shaft.
- 36) Loosen allen screw A of head #02 only 1/2 turn.
- 37) Repeat steps 30 and 31 for head #02.
- 38) RUN/LOAD to LOAD.
- 39) When LOAD light comes on, remove CE cartridge.
- 40) Disk power OFF.
- 41) Remove head alignment tool E (Figure 38) and scope probes.
- 42) Restore card cage to maintenance position by attaching the cage support wire (Figure 36).

FIGURE 40 - INCORRECT ALIGNMENT

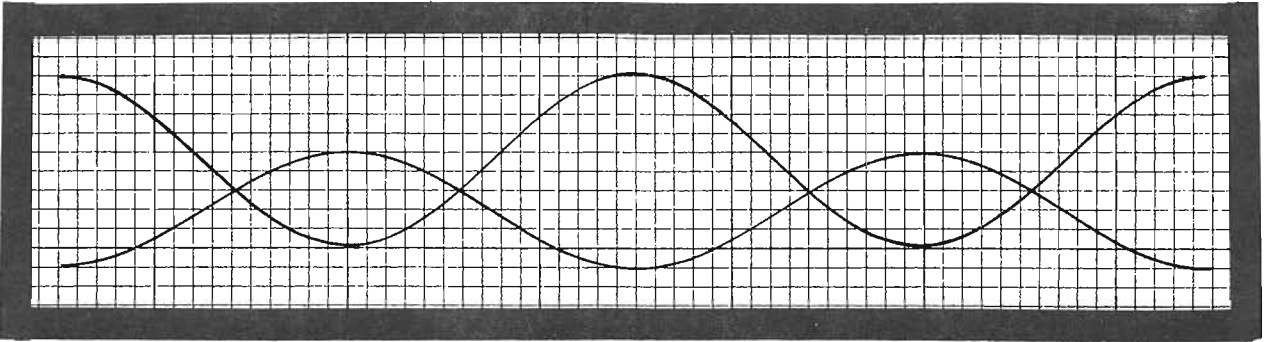

FIGURE 41 - INCORRECT ALIGNMENT

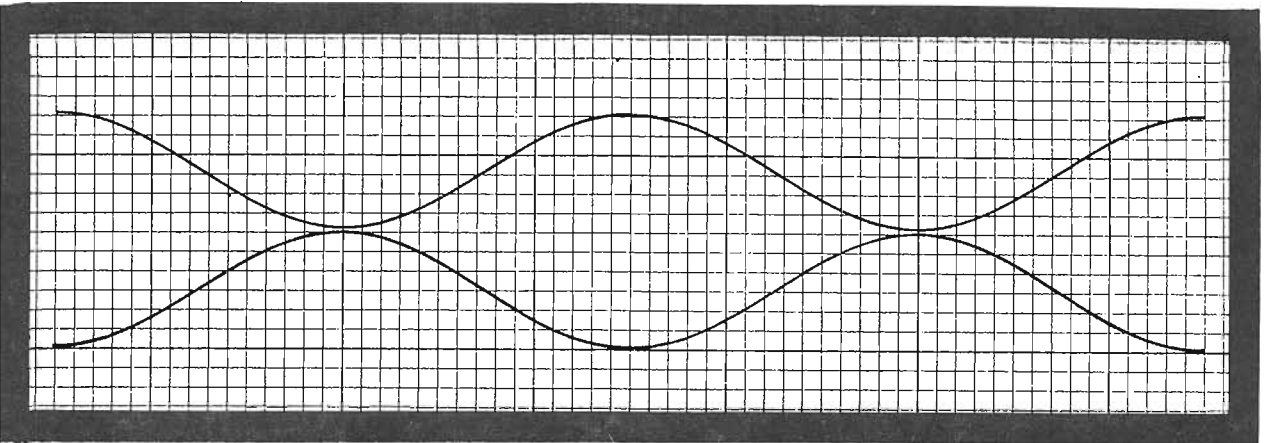
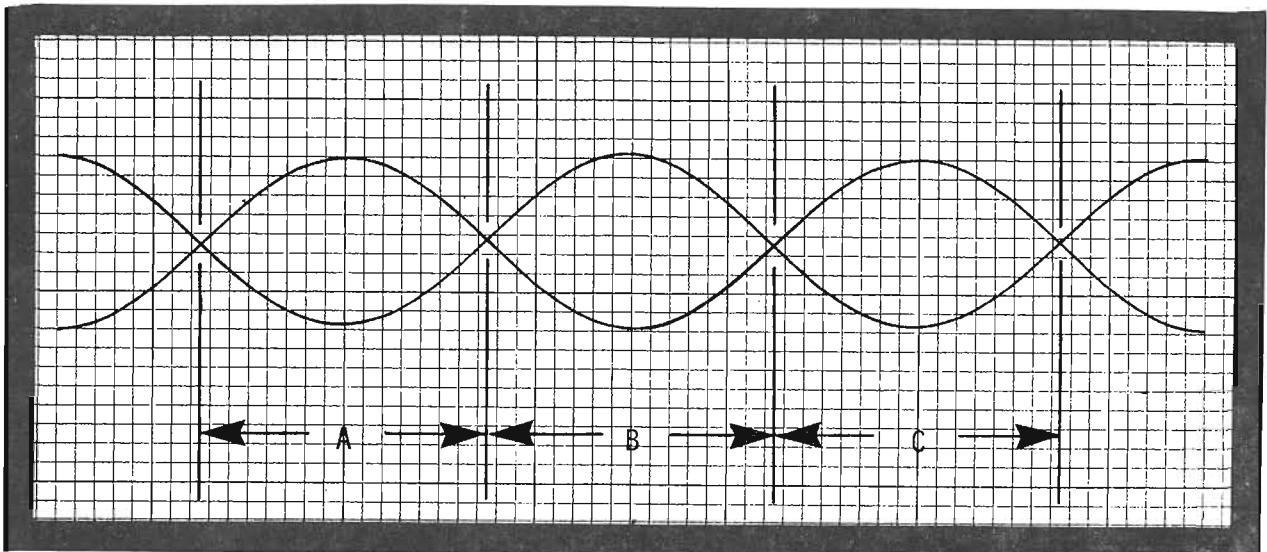

FIGURE 42 - CORRECT ALIGNMENT



LOBE A = LOBE B = LOBE C

- 43) Restore read/write module to its standard operating position. (Figure 35)
- 44) Place fan (WLI#400-1003) atop the card cage with airflow directed downward, to prevent overheating of electronics.
- 45) Disk power ON.
- 46) With LOAD light on, load standard IBM 5440 disk from the Model 30 service kit.
- 47) RUN/LOAD to RUN.
- 48) When READY light comes on, FORMAT key on; FORMAT.
- 49) When formatting has been completed, turn FORMAT key OFF, select disk (GP II, 00XX), and run all format checks and diagnostics.
- 50) If all tests verify proper Model 30 operation, switch to LOAD; remove service test cartridge, and load customer's cartridge.
- 51) LOAD/RUN to RUN. Wait for READY light.
- 52) Check customer's data and/or programs.
- 53) If all tests verify good, restore the card cage to its standard operating position (Figure 35) and replace all covers for normal disk operation.

5.5.2 *Index Transducer Alignments/Replacements*

See Diablo Maintenance Manual.

5.6 MODEL 429 POWER SUPPLY MAINTENANCE

See Diablo Model 429 Manual.

5.7 MODEL 30 CONVERSIONS

The four PROM IC's loaded in the 6298 PC board determine one of three capacities of storage of the Model 30. Figure 43 below shows the location of each PROM and the part numbers needed for the different capacities.

FIGURE 43

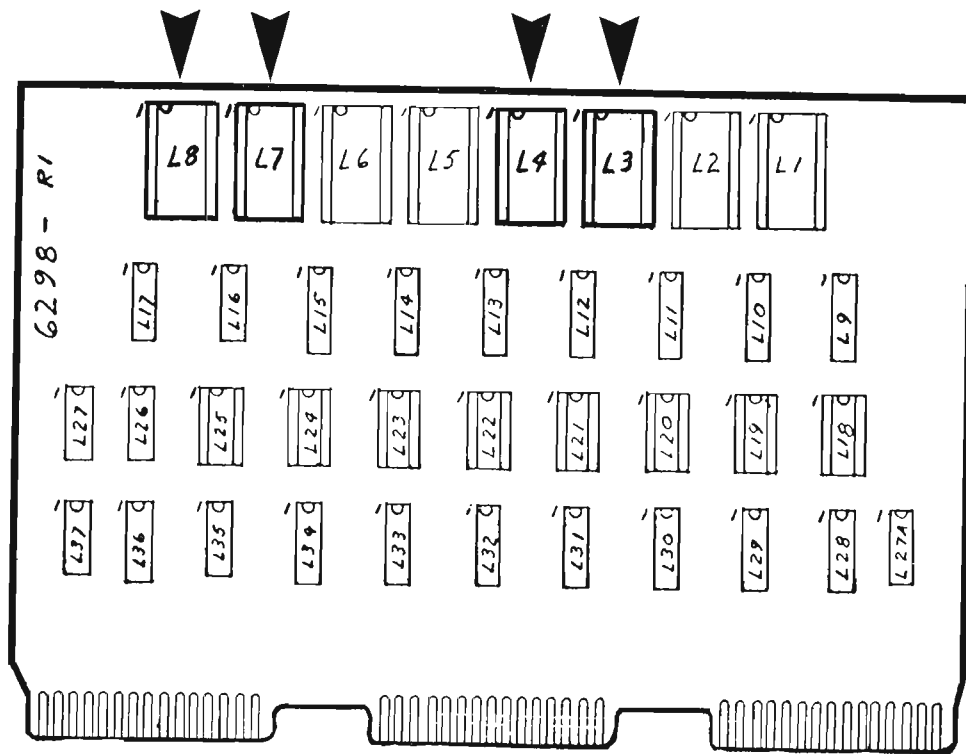

	L3	L4	L7	L8
730-1	378-0163	378-0165	378-0164	378-0166
730-2	378-0167	378-0169	378-0168	378-0170
730-3	378-0171	378-0173	378-0172	378-0174

5.8 CONTROLLER VOLTAGE CHECKS

There are two voltages that must be checked in the controller, +5 volts and -9.0 volts. The former may be checked on pin 14 of a 14 pin IC, and the latter on pin 24 of a PROM. The 341 regulator board has two adjustable pots for the voltages. The left pot controls -9.0 volts and the right pot controls +5 volts. Note that when one pot is adjusted, it affects the other adjustment. Never adjust one voltage without checking the other.

CAUTION:

1702 PROM IC's marked *ONLY* with a 1702A label should be checked and adjusted to -12 volts on pin 24; any *additional* or *different* markings other than 1702A on the PROMS indicate that a -9 volt adjustment must be made on pin 24. DO NOT INTERCHANGE BOTH TYPES IN A MIXED CONFIGURATION, due to different operating voltages.

5.9 SERVICE NOTES

CAUTION:

- A. The U-shaped metal bracket holding down the controller PC boards has sharp edges which may damage the motherboard etches during removal and installation.
- B. When servicing the controller, completely remove chassis from the main frame. The chassis may fall to the floor if this is not done.

APPENDIX - DIAGRAMS

1. IN CONNECTION WITH THE ABILITY OF WANG
 MANUFACTURING CO. TO ASSURE THE
 QUALITY OF THE PRODUCTS OF THE
 COMPANY, THE FOLLOWING IS A LIST OF
 THE QUALITY CONTROL PERSONNEL
 FOR THE MANUFACTURING DEPARTMENT.

NO.	DESCRIPTION	DATE
1	WANG	1/15/50
2	WANG	1/15/50
3	WANG	1/15/50
4	WANG	1/15/50
5	WANG	1/15/50
6	WANG	1/15/50
7	WANG	1/15/50
8	WANG	1/15/50
9	WANG	1/15/50
10	WANG	1/15/50
11	WANG	1/15/50

ITEM	QTY.	DESCRIPTION	DATE	APPROVED BY
1	1	WANG PART NO. 750	1/15/50	WANG
2	1	WANG PART NO. 750	1/15/50	WANG
3	1	WANG PART NO. 750	1/15/50	WANG
4	1	WANG PART NO. 750	1/15/50	WANG
5	1	WANG PART NO. 750	1/15/50	WANG
6	1	WANG PART NO. 750	1/15/50	WANG
7	1	WANG PART NO. 750	1/15/50	WANG
8	1	WANG PART NO. 750	1/15/50	WANG
9	1	WANG PART NO. 750	1/15/50	WANG
10	1	WANG PART NO. 750	1/15/50	WANG
11	1	WANG PART NO. 750	1/15/50	WANG
12	1	WANG PART NO. 750	1/15/50	WANG
13	1	WANG PART NO. 750	1/15/50	WANG
14	1	WANG PART NO. 750	1/15/50	WANG
15	1	WANG PART NO. 750	1/15/50	WANG
16	1	WANG PART NO. 750	1/15/50	WANG
17	1	WANG PART NO. 750	1/15/50	WANG
18	1	WANG PART NO. 750	1/15/50	WANG
19	1	WANG PART NO. 750	1/15/50	WANG
20	1	WANG PART NO. 750	1/15/50	WANG
21	1	WANG PART NO. 750	1/15/50	WANG
22	1	WANG PART NO. 750	1/15/50	WANG
23	1	WANG PART NO. 750	1/15/50	WANG
24	1	WANG PART NO. 750	1/15/50	WANG
25	1	WANG PART NO. 750	1/15/50	WANG
26	1	WANG PART NO. 750	1/15/50	WANG
27	1	WANG PART NO. 750	1/15/50	WANG
28	1	WANG PART NO. 750	1/15/50	WANG
29	1	WANG PART NO. 750	1/15/50	WANG
30	1	WANG PART NO. 750	1/15/50	WANG
31	1	WANG PART NO. 750	1/15/50	WANG
32	1	WANG PART NO. 750	1/15/50	WANG
33	1	WANG PART NO. 750	1/15/50	WANG
34	1	WANG PART NO. 750	1/15/50	WANG
35	1	WANG PART NO. 750	1/15/50	WANG
36	1	WANG PART NO. 750	1/15/50	WANG
37	1	WANG PART NO. 750	1/15/50	WANG
38	1	WANG PART NO. 750	1/15/50	WANG
39	1	WANG PART NO. 750	1/15/50	WANG
40	1	WANG PART NO. 750	1/15/50	WANG
41	1	WANG PART NO. 750	1/15/50	WANG
42	1	WANG PART NO. 750	1/15/50	WANG
43	1	WANG PART NO. 750	1/15/50	WANG
44	1	WANG PART NO. 750	1/15/50	WANG
45	1	WANG PART NO. 750	1/15/50	WANG
46	1	WANG PART NO. 750	1/15/50	WANG
47	1	WANG PART NO. 750	1/15/50	WANG
48	1	WANG PART NO. 750	1/15/50	WANG
49	1	WANG PART NO. 750	1/15/50	WANG
50	1	WANG PART NO. 750	1/15/50	WANG
51	1	WANG PART NO. 750	1/15/50	WANG
52	1	WANG PART NO. 750	1/15/50	WANG
53	1	WANG PART NO. 750	1/15/50	WANG
54	1	WANG PART NO. 750	1/15/50	WANG
55	1	WANG PART NO. 750	1/15/50	WANG
56	1	WANG PART NO. 750	1/15/50	WANG
57	1	WANG PART NO. 750	1/15/50	WANG
58	1	WANG PART NO. 750	1/15/50	WANG
59	1	WANG PART NO. 750	1/15/50	WANG
60	1	WANG PART NO. 750	1/15/50	WANG
61	1	WANG PART NO. 750	1/15/50	WANG
62	1	WANG PART NO. 750	1/15/50	WANG
63	1	WANG PART NO. 750	1/15/50	WANG
64	1	WANG PART NO. 750	1/15/50	WANG
65	1	WANG PART NO. 750	1/15/50	WANG
66	1	WANG PART NO. 750	1/15/50	WANG
67	1	WANG PART NO. 750	1/15/50	WANG
68	1	WANG PART NO. 750	1/15/50	WANG
69	1	WANG PART NO. 750	1/15/50	WANG
70	1	WANG PART NO. 750	1/15/50	WANG
71	1	WANG PART NO. 750	1/15/50	WANG
72	1	WANG PART NO. 750	1/15/50	WANG
73	1	WANG PART NO. 750	1/15/50	WANG
74	1	WANG PART NO. 750	1/15/50	WANG
75	1	WANG PART NO. 750	1/15/50	WANG
76	1	WANG PART NO. 750	1/15/50	WANG
77	1	WANG PART NO. 750	1/15/50	WANG
78	1	WANG PART NO. 750	1/15/50	WANG
79	1	WANG PART NO. 750	1/15/50	WANG
80	1	WANG PART NO. 750	1/15/50	WANG
81	1	WANG PART NO. 750	1/15/50	WANG
82	1	WANG PART NO. 750	1/15/50	WANG
83	1	WANG PART NO. 750	1/15/50	WANG
84	1	WANG PART NO. 750	1/15/50	WANG
85	1	WANG PART NO. 750	1/15/50	WANG
86	1	WANG PART NO. 750	1/15/50	WANG
87	1	WANG PART NO. 750	1/15/50	WANG
88	1	WANG PART NO. 750	1/15/50	WANG
89	1	WANG PART NO. 750	1/15/50	WANG
90	1	WANG PART NO. 750	1/15/50	WANG
91	1	WANG PART NO. 750	1/15/50	WANG
92	1	WANG PART NO. 750	1/15/50	WANG
93	1	WANG PART NO. 750	1/15/50	WANG
94	1	WANG PART NO. 750	1/15/50	WANG
95	1	WANG PART NO. 750	1/15/50	WANG
96	1	WANG PART NO. 750	1/15/50	WANG
97	1	WANG PART NO. 750	1/15/50	WANG
98	1	WANG PART NO. 750	1/15/50	WANG
99	1	WANG PART NO. 750	1/15/50	WANG
100	1	WANG PART NO. 750	1/15/50	WANG

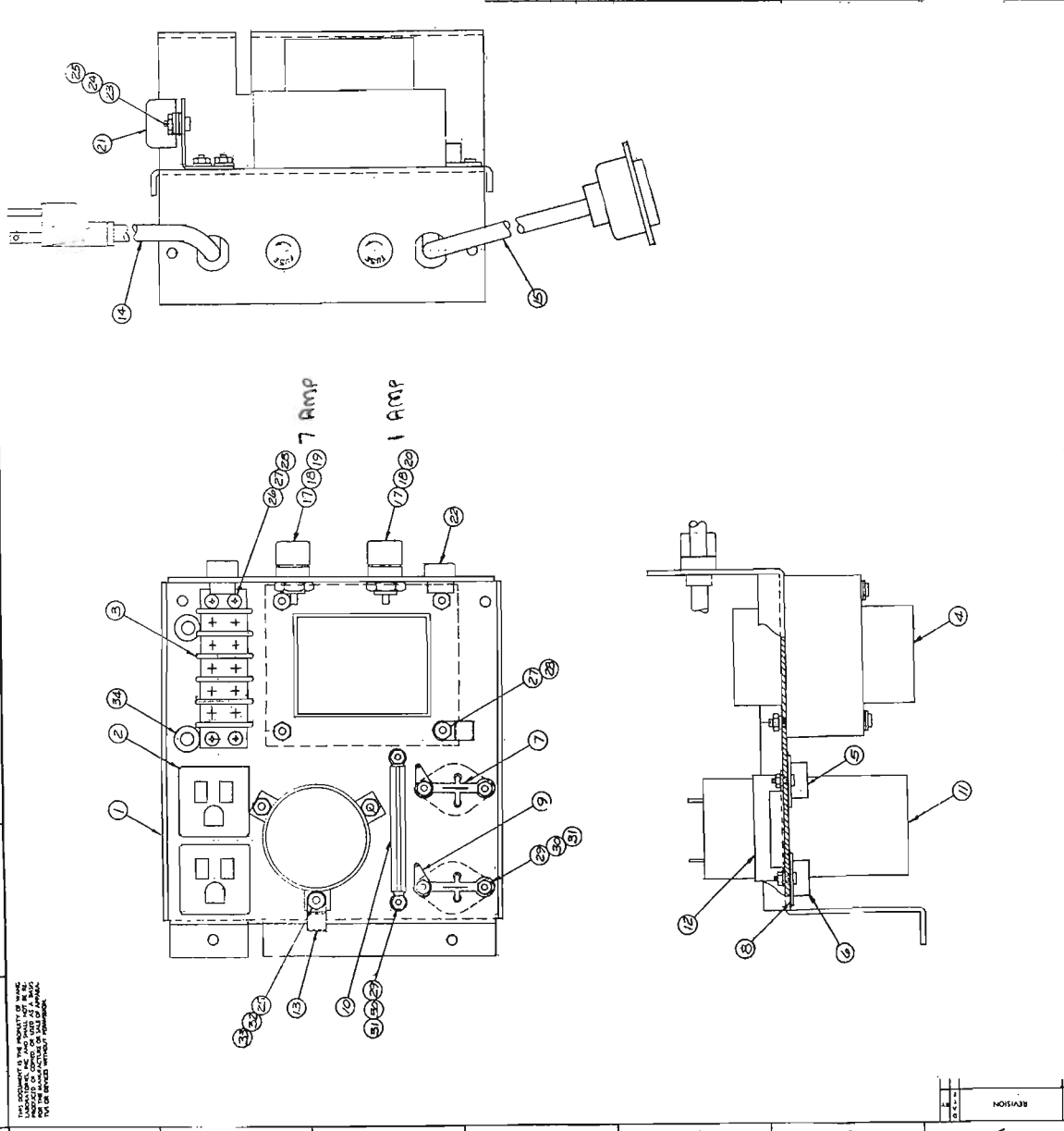

 <p>IMMEDIATE SERVICE NOTICE</p>	NO. 128A	DATE: 1/12/77
	CATEGORY MASS STORAGE DEVICES #4	
	SUBJECT MODEL 2230/2260 MARGINAL 376-0099 ALU'S ON 6296 BOARD	

3107

This ISN supersedes ISN #128 by correcting the errors contained in ISN #128.

The AMD (American Micro Devices) 74181 ALU 24 pin package, WL #376-0099, with a date code of 7644, loaded on the 6296 microprocessor board in Model 2230 and 2260 disk drives is marginal and seems to be affected by temperature. These devices are loaded in positions L11 and L20. The symptoms presented when this device fails are intermittent Error 64, 67 or 72, and can appear as hard or soft errors.

A maximum of 40 units could possibly have been shipped from Tewksbury that contain a 6296 board with these marginal devices. Suspect units have serial numbers between 932-910 and 932-970.

 <p>IMMEDIATE SERVICE NOTICE</p>	NO. 128	DATE: 12/30/76
	CATEGORY	
	MASS STORAGE DEVICES #4	
SUBJECT		
MODEL 2230		
MARGINAL 376-0219 ALU'S ON 6296 BOARD		

The AMD (American Micro Devices) ALU 24 pin package, WL #376-0219, 74181 with a date code of 7644, used on the 6296 microprocessor board in Model 2230 disk drives is marginal and seems temperature related. These devices are loaded in positions L11 and L20. The symptoms presented when this device fails are intermittent Error 64, 67 or 72 and can appear as hard or soft errors.

A maximum of 40 units could possibly have been shipped from Tewksbury that contain a 6296 board with these marginal devices. Suspect units have serial numbers between 932-910 and 932-970.



LABORATORIES, INC.

1 INDUSTRIAL AVENUE, LOWELL, MASSACHUSETTS 01851, TEL. (617) 851-4111, TWX 710-343-6769, TELEX 94-7421

Printed in U.S.A.

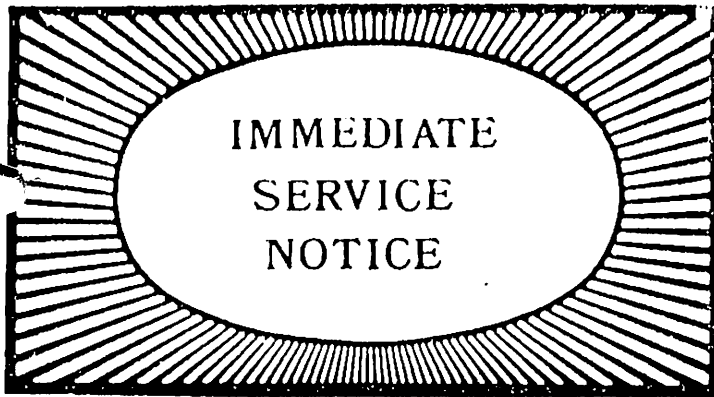

NO. 125	DATE: 12/17/76
CATEGORY	
MASS STORAGE DEVICES #3	
SUBJECT	
DIABLO DISK SR BOARDS	

ISN's 116 and 116A described SR board revisions and the electronic changes identifying each revision. The reason for the changes was to adapt to a new type of Track Zero Indicator Assembly (Diablo P/N 16485 Revision "D") which replaces the existing assembly (Diablo P/N 16485 Revision "C"). Diablo drives with serial numbers between 7850 and 7999 may or may not have the new indicator. Revision "D" indicator assemblies require a revision "N" SR PCB, revision "C" indicators are not compatible with revision "N" SR PCBs. If it becomes necessary to use a revision "N" SR PCB in a unit with a revision "C" indicator, the SR PCB must be modified to revision "L" or "M". For this modification refer to the following table.

Track Zero Sensor Assembly		B	*Rev. "C"	*Rev. "D"
SR-CB	#11411-00, -01	Rev. "L"	Rev. "M"	Rev. "N"
Resistors	K11, K12	22K	2K	2K
Resistors	K10, J14	10K	1K	1K
Resistors	K9, J15	100K	150K	68K
Resistor	K4	150 Ohm	150 Ohm	68 Ohm

*Refer to Figure 1 to identify revision level of Track Zero Sensor Assembly.

NOTE:

When exchanging SR PCBs, even of the same revision level, it is imperative that Track "0" and R/W Head Alignment be checked as the Track "0" waveform can vary with different SR PCB Assemblies.

When modifying the SR PCB Assembly from one revision level to another, it is necessary to check the Track Zero Indicator Assembly for the proper adjustment. Procedures for this adjustment are as follows:

A. USING REVISION "C" INDICATOR WITH REVISION "M" OR "L" SR-CB

- (1) Load/Run Switch in the "Load" mode, switch power to the unit on.
- (2) Connect oscilloscope channel 1/A to SR-TP3 (Vert. zero at centerline) and channel 2/B to SR-TP2 (Vert. zero at baseline). Set oscilloscope trigger to Auto, DC, 20ms/cm, Int. trig., and both channels Vert. scale 1V/cm.
- (3) Check the clearance between shutter and sensor. Distance should be $.015" \pm .003"$ with carriage near track zero (near track zero the slot on the shutter will be near the photo sensor assembly). See Figure 1.

NOTE:

Access to the Track Zero Indicator Assembly requires removal of the fixed disk. Refer to the Series 40 Maintenance Manual, Section 6.7.3.2.1.

- (4a) Move the carriage to the retracted position. Monitor the voltages at SR-TP2 and TP3. If the signals are at least 3V (Rev. A through L) or 4V (Rev. M) proceed to step (5). If the voltages are less than stated above, remove R_H from the AW-CB and test select R_H per (4b) below.

RETRACTED
3V min
2 TP 2 + 3
3.5V 3.5V

- (4b) With the carriage retracted, test select R_H to get a SR-TP2 voltage signal of 3.6V to 3.8V (Rev. A through L) or 5.5V to 6.0V (Rev. M). If these voltage levels cannot be obtained, even with an R_H value of 10 Ohms, install a 10 Ohm resistor and check for a minimum voltage of 3V (Rev. A through L) or 4V (Rev. M) at both TP2 and TP3. If the minimum voltage cannot be obtained, replace the Track Zero Sensor and test select R_H again. Do not solder in R_H until after step 7.

- (5) Move the carriage to the extended position beyond track zero. Monitor SR-TP2 and TP3 voltage signals. If TP2 is less than 0.5V and TP3 is at least two thirds (66%) of TP3 signal with the carriage in retracted position, proceed to step (6).

PAST TRK ϕ
 TP2 \leq 0.5V
 TP3 $>$ $\frac{2}{3}$ TP3
 TP2 RETRACT
 0.4V AT START
 0.8V FULLY EXT
 TP3
 3.5V

If TP2 voltage is greater than 0.5V or TP3 voltage is less than 66% of TP3 voltage in the retracted position, loosen the assembly mounting screws (Figure 1) and move the Sensor Assembly laterally to obtain as large a voltage signal at TP3 as possible, while keeping the signal at TP2 at a minimum. If the signal TP2 still exceeds 0.5V, shield the Sensor Assembly from ambient light and increase the value of R_{11} to obtain a signal of less than 0.5V. Move the carriage to the retracted position and insure that the signals at TP2 and TP3 are greater than 3V (Rev. A through L) or 4V (Rev. M). If they are not, check the SR-CB and/or the Track Zero Sensor Assembly and replace if necessary. Repeat steps (4a) and (5). Tighten the assembly mounting screws.

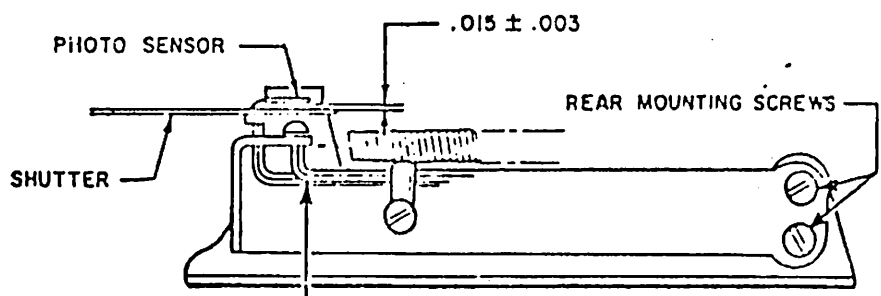
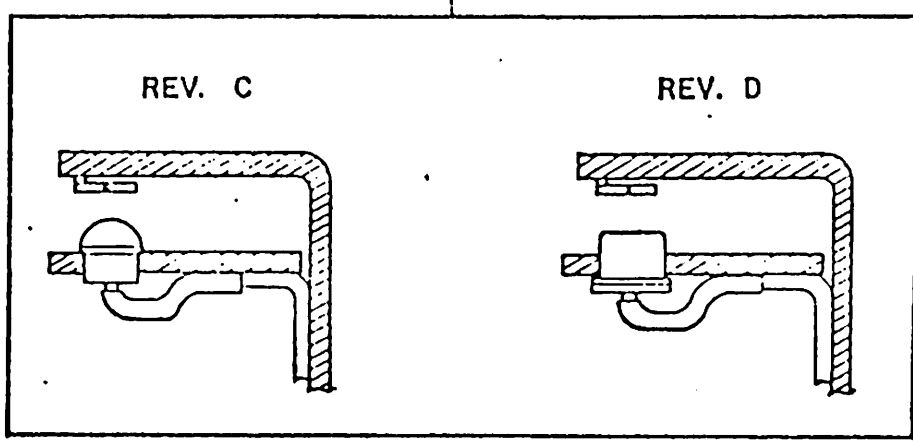

FIGURE-1



(6a) Move the carriage back and forth in the vicinity of track zero. Monitor the voltage signal at TP2. As the carriage is moved forward, from a high of greater than 3V, the signal should show a dip, then go low to near 0V. See Figure 2. If the minimum of the dip is greater than 2.5V, proceed to step (6b).

NOTCH
2.5V DIP
TP2

TP2
DIPS TO 1.7V
BACK UP TO 2.4V

T3
0V

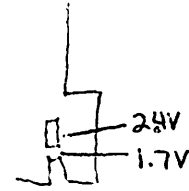
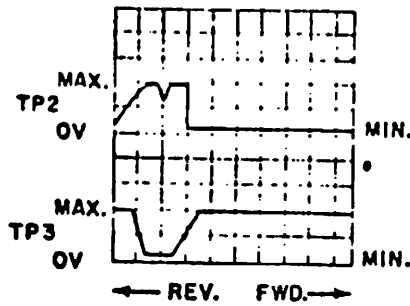

FIGURE-2

If the minimum of the dip is less than 2.5V, loosen the assembly mounting screws again and move the Sensor Assembly laterally to get at least 2.5V at the minimum of the dip. Repeat steps (5) and (6a) once only. If unable to adjust, replace the Sensor Assembly.

(6b) Monitor the voltage signal at TP3 as the carriage is moved forward in the vicinity of track zero. From a high of greater than 3V, the signal should go low to less than 0.5V and go up again to a high, just past track zero, which is at least two thirds of the signal in the retracted position. If the signal at TP3, at the low point, is greater than 0.5V, shield the Sensor Assembly from ambient light and increase the value of R_H to obtain a signal of less than 0.5V. Repeat steps (4a), (5), (6a) and (6b) once only. If unable to adjust, replace the Sensor Assembly.

AROUND TRK
TP3 < 0.5V

TP3
0V

- (7) Move the oscilloscope Vert. zero for Channel 1/A to the baseline and change both channel Vert. scales to .2V/cm. Move the carriage forward until TP2 and TP3 signals cross. The crossing voltage should be less than 1V. If it is not, test select a higher value of R_{H1} to reduce the crossing voltage to less than 1.2V. Repeat steps (4a), (5), (6) and (7) only once. (Do not readjust the value of R_{H1} during repeat steps. Replace the Sensor Assembly and/or troubleshoot the SR-CB.)

CROSSOVER
.6V

- (8) Turn power off.

After adjustment of the Track Zero Sensor Assembly, it will be necessary to perform a fine track zero adjustment, as described in the Series 40 Maintenance Manual, Section 6.6.4.5.

Readjustment of the Track Zero Sensor will require realignment of the R/W heads. Refer to the Series 40 Maintenance Manual, Section 6.6.4.3.

B. USING REVISION "D" INDICATOR WITH REVISION "N" SR-CB

- (1) Load/Run Switch in the "LOAD" mode, switch power to the unit on.
- (2) Connect oscilloscope Channel 1/A to SR-TP3 (Vert. zero at centerline) and Channel 2/B to SR-TP2 (Vert. zero at baseline). Set oscilloscope trigger to Auto, DC, 20ms/cm, Int. Trig., and both channels Vert. scale 2V/cm.
- (3) Check the clearance between shutter and sensor. Distance should be $.015" \pm .003"$ with carriage near track zero (near track zero the shutter will be near the photo sensor assembly). See Figure 1.

• NOTE:

Access to the Track Zero Indicator Assembly requires removal of the fixed disk. Refer to the Series 40 Maintenance Manual, Section 6.7.3.2.1.

- (4a) Move the carriage to the retracted position. Monitor the voltages at SR-TP2 and TP3. If the signals are at least 6V minimum to 15V maximum, proceed to step (5). If the signals are less than 6V, remove R_H from the AW-CB and test select R_H per (4b) below.
- (4b) With the carriage retracted, test select R_H to get a SR-TP2 voltage signal of 6V to 15V.
- (5) Move the carriage to the extended position beyond track zero. Monitor SR-TP2 and TP3 voltage signals. TP2 should be less than 0.5V and TP3 should be at least one half (50%) of the maximum TP3 signal with the carriage in the retracted position. If correct, proceed to step (6).

If TP2 voltage is greater than 0.5V or TP3 is less than 50% of TP3 voltage in the retracted position, loosen the assembly mounting screws (Figure 1) and move the Sensor Assembly laterally to obtain as large a voltage signal at TP3 as possible (not to exceed 15V) while keeping the signal at TP2 at a minimum (not to exceed 0.5V). If the signal at TP2 still exceeds 0.5V, shield the Sensor Assembly from ambient light and increase the value of R_H to obtain a signal of less than 0.5V. Move the carriage to the retracted position and insure that the signals at TP2 and TP3 are greater than 6V. If they are not, check the SR-CB and/or the Track Zero Sensor Assembly and replace if necessary. Repeat steps (4a) and (5). Tighten the assembly mounting screws.

- (6a) Move the carriage back and forth in the vicinity of track zero. Monitor the voltage signal at TP2. As the carriage is moved forward, from a high of greater than 6V, the signal should show a dip, then go low to near 0V. See Figure 2. If the minimum of the dip is greater than 2V, proceed to step (6b).

If the minimum of the dip is less than 2V, loosen the assembly mounting screws again and move the Sensor Assembly laterally to get at least 2V at the minimum of the dip. Repeat steps (5) and (6a).

- (6b) Monitor the voltage signal at TP3 as the carriage is moved forward in the vicinity of track zero. From a high of greater than 6V, the signal should go low to less than 0.5V and go up again to a high, just past track zero, which is at least 50% of the signal monitored in the retracted position. If the signal at TP3, at the low point, is greater than 0.5V, shield the Sensor Assembly from ambient light and increase the value of R_{11} to obtain a signal of less than 0.5V. Repeat steps (4a), (5), (6a) and (6b).
- (7) Move the oscilloscope Vert. zero for Channel 1/A to the baseline and change both channels Vert. scale to .2V/cm. Move the carriage forward until TP2 and TP3 signals cross. The crossing voltage should be less than 1.4V. If it is not, test select a higher value of R_{11} to reduce the crossing voltage to less than 1.4V. Repeat steps (4a), (5), (6), and (7) once only. (Do not readjust the value of R_{11} during repeat steps. Replace the Sensor Assembly and/or troubleshoot the SR-CB).
- (8) Turn power off.

After adjustment of the Track Zero Sensor Assembly, it will be necessary to perform a fine track zero adjustment, as described in the Series 40 Maintenance Manual, Section 6.6.4.5.

Readjustment of the Track Zero Sensor will require realignment of the R/W heads. Refer to the Series 40 Maintenance Manual, Section 6.6.4.3.



NO. 114	DATE: 5/25/76
<u>ITEM(S) / PRODUCT(S):</u> PERIPHERALS #5 DISK PROM NUMBER RESTRUCTURE UPDATE	

This ISN obsoletes ISN #54.

3107

The 630/730/2230/640/740/2240/2242/2243/2260 disk units contain PROMs on the 6298 board for different capacity units that are identical in their microprogram but contain different Wang part numbers. The PROM part numbers will be standardized so that duplicate PROMs with different part numbers will be relabeled with the lowest number of the duplicate series as illustrated in chart D. This renumbering allows the inventory of PROMs in the field to be reduced.

Presently, a complete disk PROM kit contains 84 PROMs; the renumbering of PROMs reduces the number to 49 by eliminating 35. The accompanying charts illustrate: A - Unique PROM numbers, B - PROM/Model cross reference, C - Standardized PROM numbers and D - Summary of standardized PROM numbers. Requests for additional PROMs must be submitted on a Material Transfer slip. When ordering any of the duplicate series, order only the standardized PROMs indicated in the loading chart C.

NOTE: Using the charts attached, update your copy of ISN #38.



LABORATORIES, INC.

436 NORTH STREET, TEWKSBURY, MASSACHUSETTS 01876 TEL (617) 851 4111, TWX 710 343 6769, TELEX 94 7421

Printed in U.S.

PROM LOADING OF THE 6298 BOARD

A. MODEL INDEX WITH UNIQUE PROM NUMBERING

MODEL	L3	L7	L4	L8	L1	L5
630-1	0184	0185	0186R1	0187		
630-2	0188	0189	0190R1	0191		
630-3	0192	0193	0194R1	0195		
730-1	0163	0164	0165R1	0166		
730-2	0167	0168	0169R1	0170		
730-3	0171	0172	0173R1	0174		
2230-1	0196R1	0197R1	0198R1	0199R1	0200R1	0201R1
2230-2	0202R1	0203R1	0204R1	0205R1	0206R1	0207R1
2230-3	0208R1	0209R1	0210R1	0211R1	0212R1	0213R1
2260	0356	0357	0358	0359	0360	0361
640-1	0227R1	0228R1	0229R3	0230R3		
640-2	0231R1	0232R1	0233R3	0234R3		
740-1	0214	0215	0216	0217R1	0218R2	0219R2
740-2	0220	0221	0222	0223R1	0224R2	0225R2
2240-1	0235R5	0236R5	0237R3	0238R3		
2240-2	0239R5	0240R5	0241R3	0242R3		
2242	0279R3	0280R3	0281R2	0282R2		
2243	0283R6	0284R6	0285R4	0286R5		

B. PROM/MODEL CROSS REFERENCE (PROM REVISION NOT NOTED)

PROM	CHIP	MODEL	COMMENT
378-0163	L3	630-1,-2,-3/730-1,-2,-3	Replaces 378-0167,0171,0184,0188,0192
0164	L7	730-1	
0165	L4	630-1,-2,-3/730-1,-2,-3	Replaces 378-0169,0173,0186,0190,0194
0166	L8	630-1,-2,-3/730-1,-2,-3	Replaces 378-0170,0174,0187,0191,0195
0167	L3	730-2	USE 378-0163
0168	L7	730-2	
0169	L4	730-2	USE 378-0165
0170	L8	730-2	USE 378-0166
0171	L3	730-3	USE 378-0163
0172	L7	730-3	
0173	L4	730-3	USE 378-0165
0174	L8	730-3	USE 378-0166

PROM	CHIP	MODEL	COMMENT
378-0184	L3	630-1	USE 378-0163
0185	L7	630-1	
0186	L4	630-1	USE 378-0165
0187	L8	630-1	USE 378-0166
0188	L3	630-2	USE 378-0163
0189	L7	630-2	
0190	L4	630-2	USE 378-0165
0191	L8	630-2	USE 378-0166
0192	L3	630-3	USE 378-0163
0193	L7	630-3	
0194	L4	630-3	USE 378-0165
0195	L8	630-3	USE 378-0166
0196	L3	2230-1,-2,-3	Replaces 378-0202,0208
0197	L7	2230-1	
0198	L4	2230-1,-2,-3	Replaces 378-0204,0210
0199	L8	2230-1,-2,-3	Replaces 378-0205,0211
0200	L1	2230-1,-2,-3	Replaces 378-0206,0212
0201	L5	2230-1,-2,-3	Replaces 378-0207,0213
0202	L3	2230-2	USE 378-0196
0203	L7	2230-2	
0204	L4	2230-2	USE 378-0198
0205	L8	2230-2	USE 378-0199
0206	L1	2230-2	USE 378-0200
0207	L5	2230-2	USE 378-0201
0208	L3	2230-3	USE 378-0196
0209	L7	2230-3	
0210	L4	2230-3	USE 378-0198
0211	L8	2230-3	USE 378-0199
0212	L1	2230-3	USE 378-0200
0213	L5	2230-3	USE 378-0201
0214	L3	740-1,-2	Replaces 378-0220
0215	L7	740-1,-2	Replaces 378-0221
0216	L4	740-1,-2	Replaces 378-0222
0217	L8	740-1,-2	Replaces 378-0223
0218	L1	740-1	
0219	L5	740-1	
0220	L3	740-2	USE 378-0214
0221	L7	740-2	USE 378-0215
0222	L4	740-2	USE 378-0216
0223	L8	740-2	USE 378-0217
0224	L1	740-2	
0225	L5	740-2	

PROM	CHIP	MODEL	COMMENT
378-0227	L3	640-1	
0228	L7	640-1	
0229	L4	640-1,-2	Replaces 378-0233
0230	L8	640-1,-2	Replaces 378-0234
0231	L3	640-2	
0232	L7	640-2	
0233	L4	640-2	USE 378-0229
0234	L8	640-2	USE 378-0230
0235	L3	2240-1	
0236	L7	2240-1	
0237	L4	2240-1,-2/2242	Replaces 378-0241,0281
0238	L8	2240-1,-2/2242	Replaces 378-0242,0282
0239	L3	2240-2	
0240	L7	2240-2	
0241	L4	2240-2	USE 378-0237
0242	L8	2240-2	USE 378-0238
0279	L3	2242	
0280	L7	2242	
0281	L4	2242	USE 378-0237
0282	L8	2242	USE 378-0238
0283	L3	2243	
0284	L7	2243	
0285	L4	2243	
0286	L8	2243	
0356	L3	2260	
0357	L7	2260	
0358	L4	2260	
0359	L8	2260	
0360	L1	2260	
0361	L5	2260	

C. MODEL INDEX WITH STANDARDIZED PROM NUMBERING

MODEL	L3	L7	L4	L8	L1	L5
630-1	0163	0185	0165R1	0166		
630-2	0163	0189	0165R1	0166		
630-3	0163	0193	0165R1	0166		
730-1	0163	0164	0165R1	0166		
730-2	0163	0168	0165R1	0166		
730-3	0163	0172	0165R1	0166		
2230-1	0196R1	0197R1	0198R1	0199R1	0200R1	0201R1
2230-2	0196R1	0203R1	0198R1	0199R1	0200R1	0201R1
2230-3	0196R1	0209R1	0198R1	0199R1	0200R1	0201R1
2260	0356	0357	0358	0359	0360	0361
640-1	0227R1	0228R1	0229R3	0230R3		
640-2	0231R1	0232R1	0229R3	0230R3		
740-1	0214	0215	0216	0217R1	0218R2	0219R2
740-2	0214	0215	0216	0217R1	0224R2	0225R2
2240-1	0235R5	0236R5	0237R3	0238R3		
2240-2	0239R5	0240R5	0237R3	0238R3		
2242	0279R3	0280R3	0237R3	0238R3		
2243	0283R6	0284R6	0285R4	0286R5		

D. SUMMARY OF STANDARDIZED PROM NUMBERS

PROM	CHIP	MODEL
1. 378-0163	L3	630-1,-2,-3/730-1,-2,-3
2. 0164	L7	730-1
3. 0165	L4	630-1,-2,-3/730-1,-2,-3
4. 0166	L8	630-1,-2,-3/730-1,-2,-3
5. 0168	L7	730-2
6. 0172	L7	730-3
7. 0185	L7	630-1
8. 0189	L7	630-2
9. 0193	L7	630-3
10. 0196	L3	2230-1,-2,-3
11. 0197	L7	2230-1
12. 0198	L4	2230-1,-2,-3
13. 0199	L8	2230-1,-2,-3
14. 0200	L1	2230-1,-2,-3
15. 0201	L5	2230-1,-2,-3
16. 0203	L7	2230-2
17. 0209	L7	2230-3
18. 0214	L3	740-1,-2
19. 0215	L7	740-1,-2
20. 0216	L4	740-1,-2
21. 0217	L8	740-1,-2
22. 0218	L1	740-1

	PROM	CHIP	MODEL
23.	378-0219	L5	740-1
24.	0224	L1	740-2
25.	0225	L5	740-2
26.	0227	L3	640-1
27.	0228	L7	640-1
28.	0229	L4	640-1,-2
29.	0230	L8	640-1,-2
30.	0231	L3	640-2
31.	0232	L7	640-2
32.	0235	L3	2240-1
33.	0236	L7	2240-1
34.	0237	L4	2240-1,-2/2242
35.	0238	L8	2240-1,-2/2242
36.	0239	L3	2240-2
37.	0241	L4	2240-2
38.	0279	L3	2242
39.	0280	L7	2242
40.	0283	L3	2243
41.	0284	L7	2243
42.	0285	L4	2243
43.	0286	L8	2243
44.	0356	L3	2260
45.	0357	L7	2260
46.	0358	L4	2260
47.	0359	L8	2260
48.	0360	L1	2260
49.	0361	L5	2260



NO. 116A

DATE: 8/24/76

ITEM(S) / PRODUCT(S):

MODEL 630/730/2230/2260 DISKS
DIABLO BOARD COMPATABILITY

ISN #116 described the three Diablo SR boards and stated Customer Engineers should contact the Area Technical Specialists for E Rev information.

To allow everyone to easily identify SR boards, and to prevent numerous phone calls to the Area Offices, the following describes the SR board differences and is for your information:

-00/-01 Rev. "L"; -02/-03 Rev. "C"

1. Resistors K11 and K12 are 22K ohm.
2. Resistors K10 and J14 are 10K ohm.
3. Resistors K9 and J15 are 100K ohm.
4. Resistor K4 is 150 ohm.

-00/-01 Rev. "M"; -02/-03 Rev. "D"

1. Resistors K11 and K12 are 2K ohm.
2. Resistors K10 and J14 are 1K ohm.
3. Resistors K9 and J15 are 150K ohm.
4. Resistor K4 is 150 ohm.

-00/-01 Rev. "N"; -02/-03 Rev. "E"

1. Resistors K11 and K12 are 2K ohm.
2. Resistors K10 and J14 are 1K ohm.
3. Resistors K9 and J15 are 68K ohm.
4. Resistor K4 is 68 ohm.

Do not change the E Rev of the SR board unless it is absolutely necessary, and then, always be sure to mark the E Rev on the board. Failure to mark the board or indiscriminate E Rev changes could result in many hours spent troubleshooting a disk problem induced by a Customer Engineer.

WANG

LABORATORIES, INC

1138 NORTH STREET NEWBURY, MASSACHUSETTS 01876 TEL (617) 851 4111, TWX 710 343 6769, TELEX 94 7421

1700-001-01



NO. 116	DATE: 7/7/76
<u>ITEM(S) / PRODUCT(S):</u> MASS STORAGE DEVICES #1	

MODEL 630/730/2230/2260 DISKS - DIABLO BOARD COMPATABILITY

A. DIABLO 11411 SR BOARD INTERCHANGEABILITY

Currently there are three types of Diablo SR boards used in the Diablo Series 40 disk drives (Wang 630/730/2230/2260). These boards are designated as E revision L, M, and N. In general, an SR board may only be replaced by one of the same E revision; failure to do so will result in improper head positioning. If a disk drive is serviced and requires a different E revision level board than is available, contact your Area Technical Specialist for instructions.

B. DIABLO OR AND SL BOARD COMPATIBILITY

Two different types of OR and SL boards exist: the old OR board is number 11414 and the new one is 11873; the old SL board is number 11471-00/01 and the new is 11471-02/03. Both types of OR boards can be used in the 630/730/2230/2260 while the -00 and -02 SL boards are used in the 630/730/2230 and the -01 and -03 SL boards are used in the 2260. The chart below illustrates legal OR and SL configurations:

OLD SL 11471-00/01	YES	YES	
NEW SL 11471-02/03))	YES*
OLD OR 11414	YES))
NEW OR 11873		YES	YES*

*To use the new OR board with a new SL board in a disk drive with a Diablo serial number prior to 6560, on the card cage motherboard, connect a jumper from M05 pin T to M02 pin 17.



LABORATORIES, INC

830 NORTH STREET, TEWKSBURY, MASSACHUSETTS 01876 TEL (617) 851-4111, FWX 710 343 6761, TELEX 94 7421

Printed in U.S.

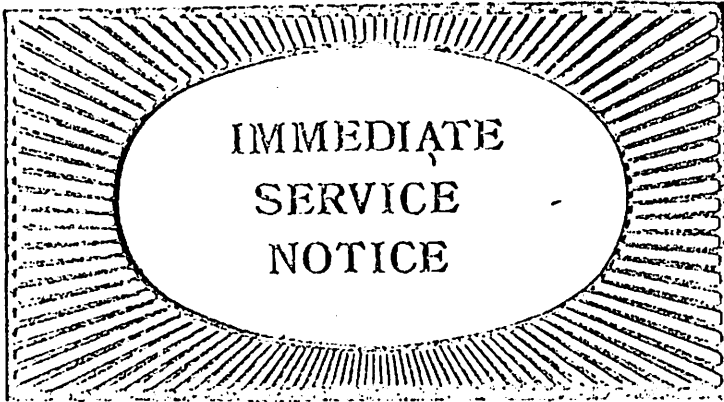

NO. 81	DATE: 6/30/75
ITEM(S) / PRODUCT(S): NEW HEATSINK BOARD MODELS 630/730/2230/2260	

THIS DTABLO MODIFICATION IS PRINTED FOR INFORMATION ONLY

The new heatsink assembly is upward compatible, without modification, due to the new wire harness terminal strip connectors. Since the stand-off wire terminals have been removed, the wire harness in earlier units must be cut to a new length to be used with the new terminal strip. Once this has been done, earlier heatsink assemblies can no longer be used on the modified unit.

Also, the Spindle Drive (SD) PCB Part #11613 must be at revision "H" to be compatible with the new Heatsink Assembly.

The units starting with the following serial numbers contain the new heatsink board:

630	Not Available
730	Not Available
2230	Not Available
2260	SN 932-080 and up

The following is a list of changes:

- 1) A type 555 IC timer is used for spindle dynamic braking.
- 2) A type 1468 IC tracking regulator is used in the +15 volt and -15 volt power supplies.
- 3) Each Darlington circuit is incorporated in a TO3 package eliminating discrete components. The type 5879 and 5881 power transistors are no longer used.
- 4) The Servo Inhibit Circuit is incorporated.
- 5) "Standoff" terminals are replaced with a terminal strip.

If a new heatsink assembly is to be installed in an earlier unit, the following procedure should be used.



LABORATORIES, INC

810 NORTH STREET, LEWISBURG, MASSACHUSETTS 01876 TEL (617) 851-4111, TWX 710 343 6769, TELEX 94 7421

- a) Wire cutters/strippers
- b) Terminal lug crimper
- c) Terminal lugs, as follows:

<u>Part #</u>	<u>Description</u>	<u>Qty. Per Unit</u>
10616-06	Ring Lug	1
10780	Spade Lug	16

2) Remove the old heatsink assembly by following the procedure in the Series 40 Maintenance Manual-First Edition, page 6-14, paragraph 6.7.2.7.

CAUTION:

Care should be taken when removing wires. They must be labeled for accurate reconnection.

3) New Heatsink Installation

- a) Install the new heatsink assembly using the Maintenance Manual procedure stated above except for connection of the wire harness.
- b) Wires from the harness are attached by following the labels on the PCB below the terminal strip. These labels match the labels on the old heatsink assembly except for location.
- c) Wires are cut to length and 1/4" of insulation is stripped from the ends. Attach (crimp) new lugs to the wire ends. The one "Ring Lug" goes on the yellow wire at terminal 10 of the new heatsink assembly (see item 5). A "Spade Lug" attaches the remaining (purple/black) wires to terminal 10.

CAUTION:

When measuring wire length, do not cut too short.

4) Wire Chart - Old Heatsink Assembly.

<u>Location</u>	<u>Color</u>
P7-1	Yellow
P7-2	Blue
P7-3	Green
P7-4	Brown
P7-5	Orange
P7-6	Gray
P7-7	White
P7-8	Red
P7-9	Black
P7-10	Purple
P7-11	Blue

<u>Location</u>	<u>Color</u>
P7-12	Green
+24 CKT	Purple/Black/Yellow
+24 PWR	Green/Yellow
-24 CKT	Orange/Blue
-24 PWR	Brown/Gray
PLUS	White
MINUS	Black

- 5) Wire Chart - New Heatsink Assembly (Terminals counted from left to right)

<u>Terminal</u>	<u>Location</u>	<u>Color</u>	
1	P7-4	Brown	
2	P7-5/P7-6	Gray/Orange	
3	P7-8	Red	} BRUSH MOTOR
4	P7-7	White	
5	-24 PWR	Brown/Gray	
6	P7-2/P7-3	Blue/Green	
7	P7-1	Yellow	
8	+24 PWR	Green/Yellow	
9	★ P7-11	Blue	HEAD LOAD SOLENOID
10	★ +24 CKT	Purple/Black/Yellow	
11	-24 CKT	Orange/Blue	
12	PLUS	White	} SERVO POSITIONAL
13	MINUS	Black	
14	P7-9	Black	DRUMS UNDER SERVO
15	→ P7-12	Green	HEAD LOAD SOLENOID
16	P7-10	Purple	LOAD LITE

SEE SERVICE NEWSLETTER #51

- 6) SD-CB revision "A-F" to "H", change the following component:

<u>Was</u>	<u>Change To</u>
J12 - 1 μ F 35V	J12 - 6.8 μ F 35V, Part #10076-68

- 7) SD-CB revision "G" to "H", change the following components:

<u>Was</u>	<u>Change To</u>
F6 - 2.4K 5%	F6 - 1K 5%, Part #10023-10
H6 - 510K 5%	H6 - 3M 5%, Part #10026-30
H14 - 2.7M 5%	H14 - 1M 5%, Part #10026-10
J12 - 10 μ f 15V	J12 - 6.8 μ f 35V, Part # 10076-68

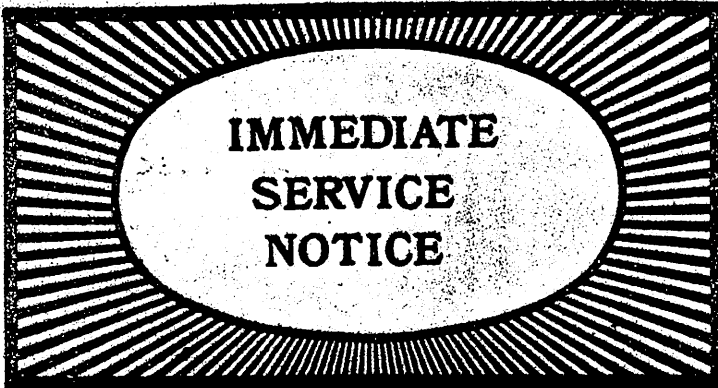

NO. 75.1	DATE: 5/9/75
ITEM(S) / PRODUCT(S): MODEL 30/60 HEAD LOAD PROBLEMS	

ISN #75 IS VOID.

Several instances of Model 30's, and 60's, failing to load the heads in a LOAD to RUN sequence have occurred. In most instances the blame was placed on the head load solenoid or the tension of the return spring on the solenoid. We have been informed by Diablo that the fix for this problem is electronic. First, the head load pick time should be doubled; this is accomplished by changing the value of the resistor A_{13} on the SL board from 27K to 39K and changing the value of capacitor A_{12} from 39 μ f to 47 μ f. Second, the holding current for the solenoid should be decreased to decrease the operating temperature of the solenoid; this is accomplished by changing the value of the resistor loaded between R_3 and R_4 at location H110 on the HS board from 20 Ω 10 watt to 30 Ω 10 watt. This resistor is physically mounted on the heat sink.

The 39K resistor is WLI #330-4039 and the 47 μ f capacitor is WLI #300-4020; the 30 Ω 10 watt resistor Diablo Part #10057-30 must be requested from the Home Office to the attention of Dave Marr.

APPROX 12V BETWEEN

TBI - 9	TBI - 15	
P7-11	P7-12	WHEN PICKED (OPERATING)
BLUE	GREEN	
24V	11.5V	
25.1V	25.1V	NOT PICKED
25.1	-5	UNSCREWED



LABORATORIES, INC

415 NORTH STREET, TOWNSBURY, MASSACHUSETTS 01876 TEL: (617) 851-4111 TWX: 310-957-7621

Printed in U.S.A.

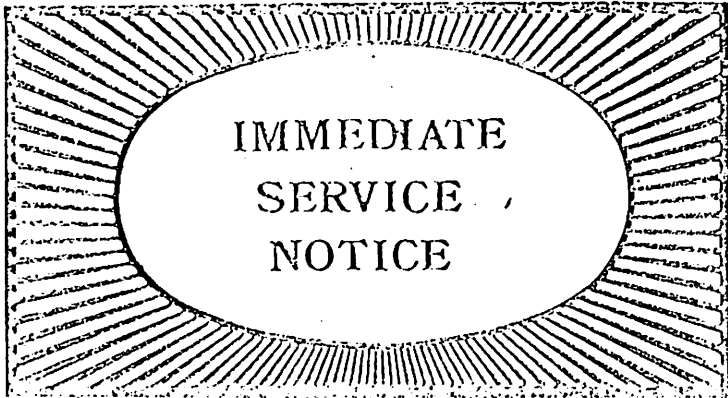

NO. 45

DATE: 1/16/75

ITEM(S) / PRODUCT(S):

2230/2260 SERVICE NOTES

I. DIABLO PC BOARD LABELING

To avoid confusion between the PC board compliments for the Diablo Model 43 (Wang 2230) and the Diablo Model 44 (Wang 2260), the Customer Engineering Division will label certain 2230-only and 2260-only Diablo PC boards with a Brady label "3" for Diablo Model 43 or a "4" for Diablo Model 44. This label will be attached to the wiring side. Diablo boards that can be used interchangeably between 2230's and 2260's will *not* be labeled. If a Diablo Model 43 (2230) PC board is field updated for Model 44 use per ISN #31, it must be labeled accordingly. The following Diablo boards require either a Brady "3" or "4" label as described above (Ref: ISN #31).

2230 (Model 43) Boards
Requiring a "3" Label:

<u>Designation</u>	<u>Diablo #</u>
AL-1-CB	11404-00
AL-2-CB	11407-00
SO-CB	11633-00
OR-CB	11414-00
RW-CB	11486-02
IO2-CB	11433
RDR2-CB	11637-00
D/CS-CB	11429-00
	11637-00

2260 (Model 44) Boards
Requiring a "4" Label:

<u>Designation</u>	<u>Diablo #</u>
AL-1-CB	11404-20
AL-2-CB	11407-20
SO-CB	11633-20
SL-CB	11471-01
OR-CB	11414-01
RW-CB	11486-20
IO2-CB	11504
RDR2-CB	11647-00
D/CS-CB	11429-01
	11637-01

II. SPINDLE DRIVER P.C.B. (SD-CB) COMPATIBILITY

It has been found that in some marginal cases the Heat sink PC board (HS-CB), #11631-XX or #11418, is not compatible with the Spindle Driver PC board, #11416 or #11613. The problem encountered is that the dynamic brake releases and the drive enters the Load Mode before the spindle has come to a complete stop.



LABORATORIES, INC.

866 SOUTH STREET, NEW BURY, MASSACHUSETTS 01938 TEL: (617) 851-4111 FAX: 710-9411/9511/9611/9711/9811/9911

The following changes to the HS-CB and SD-CB will correct the above problem, and are included on production units with boards at the following revision levels:

HS-CB	#11418	Revision P
	#11631-00	Revision G
	#11631-01	Revision F
SD-CB	#11613-XX	Revision F
	#11416	Revision E

1) HS-CB (Figure 1)

- (a) Remove the resistors at locations E27 and E33.
- (b) Install a zener diode assembly, Diablo part #10782 (Figure 2), at location E27. Location E33 remains vacant.

NOTE:

The zener diode assembly can be made from two 6.2V zener diodes, Diablo part #10103-02, cathodes soldered together and covered with shrink tubing, Diablo part #10567-25.

2) SD-CB (Figure 3)

Remove the 1M 1/4W resistor at location H6 and replace with a 3M 1/4W resistor, Diablo part #10026-30.

3) Parts Required

<u>Diablo Part #</u>	<u>Description</u>	<u>Qty</u>
10782	Zener Diode Assembly	1
10026-30	Resistor, 3M 1/4W 5%	1

NOTE:

To use the SD-CB 11613-XX Revision F or 11416 Revision E with a 3M 1/4W resistor at location H6, no changes are required on the HS-CB 11631-01 Revisions J and H.

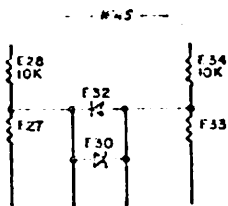

FIGURE 1

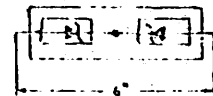
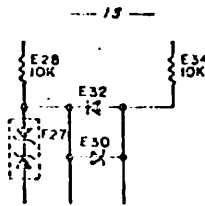

FIGURE 2

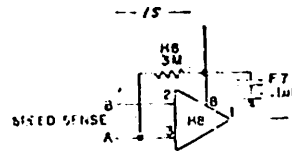
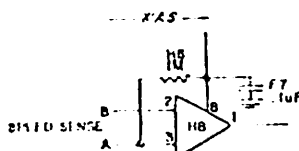

FIGURE 3

MASS STORAGE DEVICES #6 DIABLO HEAD LOAD BAIL ADJUSTMENT

August 23, 1976

The Western Area has encountered several Diablo drives with a problem in the head load mechanism. Specifically, the head load bails are out of adjustment causing the heads to fly at varying distances from the disk surface. This results in intermittent errors and incompatibility to its own and other disks.

The problem has occurred on both the new and old disk drives.

The solution is to adjust the head load bails per the following procedure:

1. With disk rotation stopped, check for $.062 \pm .010$ (1.57 mm \pm .25 mm) clearance between head H-00 slider and the recording disk, adjusted by turning eccentric (A), keeping the "throw" of the eccentric generally to the right side of the disk file. Tighten screw (B).
2. Check for $.062 \pm .010$ (1.57 mm \pm .25 mm) clearance between head H-01 slider and the recording disk, adjusted by turning eccentric (C), keeping the "throw" of the eccentric generally towards the bottom. Tighten nut (D).
3. Repeat step #1 for head H-02 (top head of fixed disk).
4. Repeat step #2 for head H-03 (bottom head of fixed disk).
5. Load the R/W heads, check to see that clearance exists between the four (E) rollers and four (F) loading bails.

NOTE:

Steps one and two adjustments, if required, must be done in proper order.

WANG

LABORATORIES, INC

836 NORTH STREET, TEWKSBURY, MASSACHUSETTS 01876, TEL (617) 851 4111, TWX 710 343 6769, TELEX 94 7421

Printed in U.S.A.
13-266

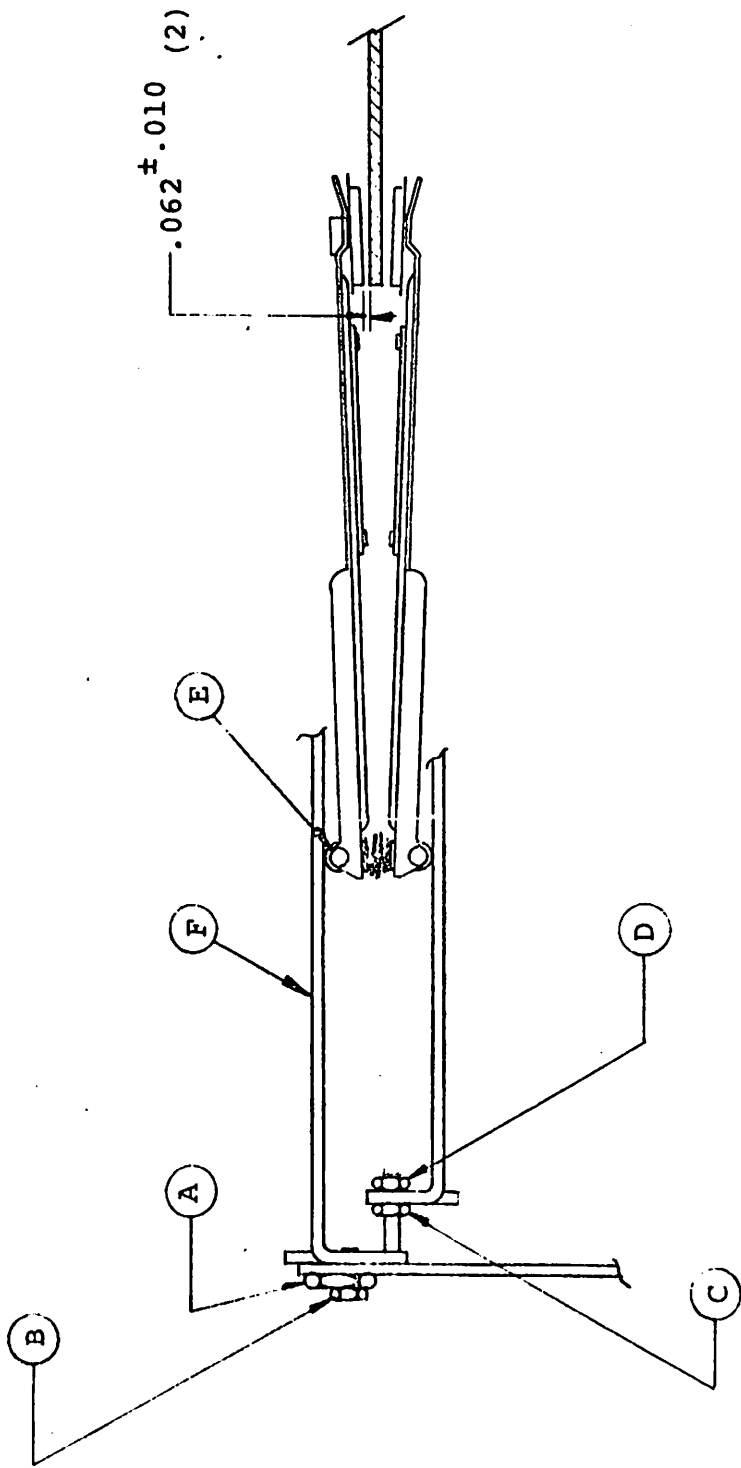

Service Newsletter

#51

July 9, 1976

MASS STORAGE DEVICES #5 DIABLO WIRING HARNESS CHANGES

*HYA
OND
STYLE*

ISN #81 described the Diablo 11890 Heat Sink and provided a wire run list in item 5. Effective with approximately Diablo Serial Number 6093, that wire list is not correct and reference to the following list is required:

<u>Terminal</u>	<u>Location</u>	<u>Color</u>
1	P7-4	Yellow/Brown
2	P7-5/P7-6	Blue/Brown
3	P7-8 \bar{I}	Small Pink
4	P7-7	Small White
5	-24 PWR	Brown
6	P7-2/P7-3	Red
7	P7-1	Green
8	+24 PWR	Orange
9	P7-11	Blue HEAD LOAD SOLLENOID +24
10	+24 CKT	Small Yellow and Large Yellow
11	-24 CKT	Pink
12	PLUS	White
13	MINUS	Black
14	P7-9	Small Black DRAWER UNLOCK SOLENOID
15	P7-12	Green HEAD LOAD SOLLENOID
16	P7-10	Violet LOAD LITE

BRUSH MOTOR

SERVO MOTOR

WANG

LABORATORIES, INC.

836 NORTH STREET, TEWKSBURY, MASSACHUSETTS 01876, TEL (617) 851-4111, TWX 710 343 6769, TELEX 94 7421

Printed in U.S.A.
13-266

EDITED BY CUSTOMER ENGINEERING DIVISION

AUGUST 4, 1976

MODEL 2260-2 TWENTY MEGABYTE DISK DRIVE SYSTEM

TABLE OF CONTENTS

1.	INTRODUCTION	3
2.	INSTALLATIONS	4
	2.1 INSTALLATION OF NEW SYSTEM	4
	2.2 FIELD UPGRADE WITH CONVERSION KIT	5
3.	SYSTEM OPERATION & TESTING	10
4.	CIRCUIT BOARD CHANGES	11

NOTICE:

This document is the property of Wang Laboratories, Inc. Information contained herein is considered company proprietary information and its use is restricted solely to the purpose of assisting you in servicing Wang products. Reproduction of all or any part of this document is prohibited without the consent of Wang Laboratories.

WANG

LABORATORIES, INC.

838 NORTH STREET, TEWKSBURY, MASSACHUSETTS 01876, TEL. (617) 851-4111, TWX 710 343-6769, TELEX 94-7421

Printed in U.S.A.
13-210A

MODEL 2260-2 TWENTY MEGABYTE DISK DRIVE SYSTEM

1. INTRODUCTION

To meet the user's ever increasing need for larger disk systems, a product is now available that effectively provides 20 Megabytes of disk storage from a single I/O controller. The system uses one Wang Disk Microprocessor and two Diablo Ten Megabyte Disk Drives and is designated as the Model 2260-2.

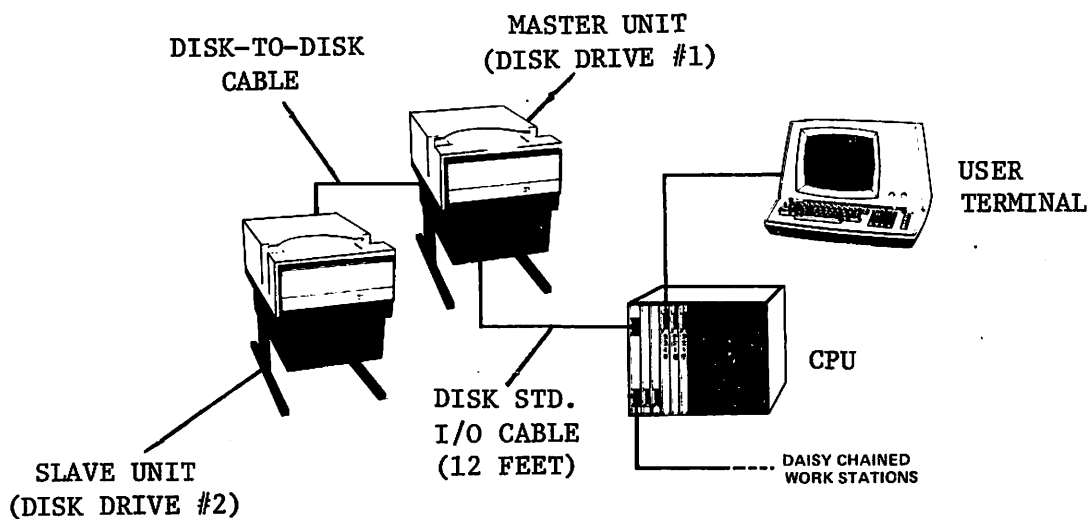

FIGURE 1 - TYPICAL 20 MEGABYTE SYSTEM

System operation is similar to that of a Model 2243 Triple Disk System, where the HEX 40 bit is used in the disk select address to specify the 'third' drive. In the 20M byte system, when the HEX 40 bit is used in the disk address, the second 10M byte drive is selected. Both fixed and removable platters may then be accessed as an independent drive. When used with a multiplexer, either drive can be programmed to the hog mode. For example, if the controller address is set to HEX X10, the program addresses for the first drive are HEX 310 and B10; the program addresses for the second drive are HEX 350 and B50. Hog mode addresses for the first and second drives are HEX 390 (B90) and 3D0 (BD0), respectively. Note that 2230 platters can no longer be read on either of the 2260-2 drives by using the HEX 40 bit.

2. INSTALLATIONS

2.1 INSTALLATION OF NEW SYSTEM (NO MODIFICATIONS NECESSARY)

- a) Remove the terminator and terminator cover from the rear panel of Drive 2. Insure the disk select plug is in position 2 (Figure 2).

PLUG REMOVED FROM POSITION 1 (DOTTED LINE) AND
REINSERTED IN POSITION 2 (SOLID LINE)

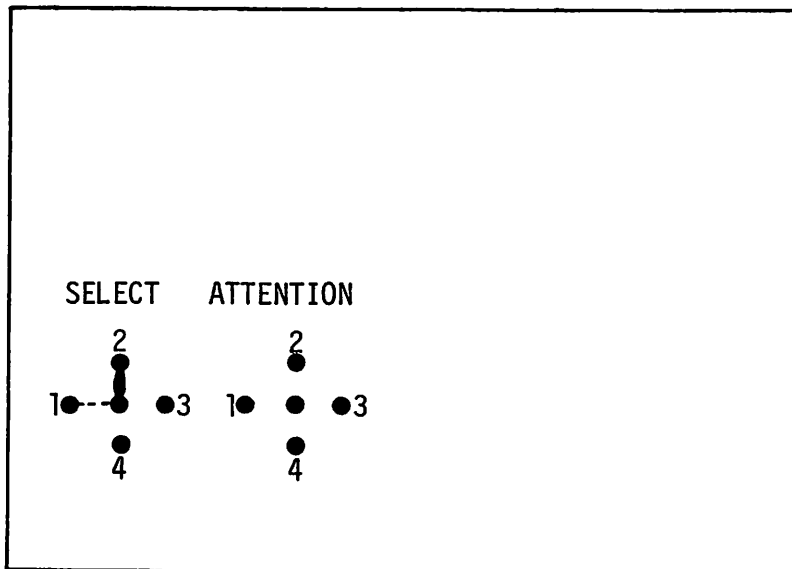

FIGURE 2 - DISK DRIVE SELECT PLUG

- b) Replace the terminator and cover on Drive 2.
- c) Connect the modified disk-to-disk cable (WL #220-0151) between Drive 1 and Drive 2 (Figure 1).
- d) Connect the I/O cable from Drive #1 to the disk controller board in the 2200 CPU (Figure 1).

2.2 FIELD UPGRADE WITH CONVERSION KIT
(UPGRADE FROM 10M BYTE SYSTEM TO 20M BYTE SYSTEM)

PARTS LIST - 20M BYTE CONVERSION

CORRECT

1. Front panel, Master unit: WL #451-2137.
2. Cable, Disk-to-Disk: WL #220-0151.
3. Cable, Disk-to-Microprocessor: WL #220-0150.
4. Connector Plate: WL #451-1255.
5. 6295-1 PC: WL #210-6295-1.
6. Switch, Drive Select: WL #325-0014.
7. 10 Megabyte Disk Drive and Stand (Slave Unit): WL #XXX-XXXX.

- a) Remove the Wang microprocessor chassis from Drive #1 (Master).
- b) Install a toggle switch (WL #325-0014) in the second hole from the right side of the chassis, as viewed from the front (Figure 3).

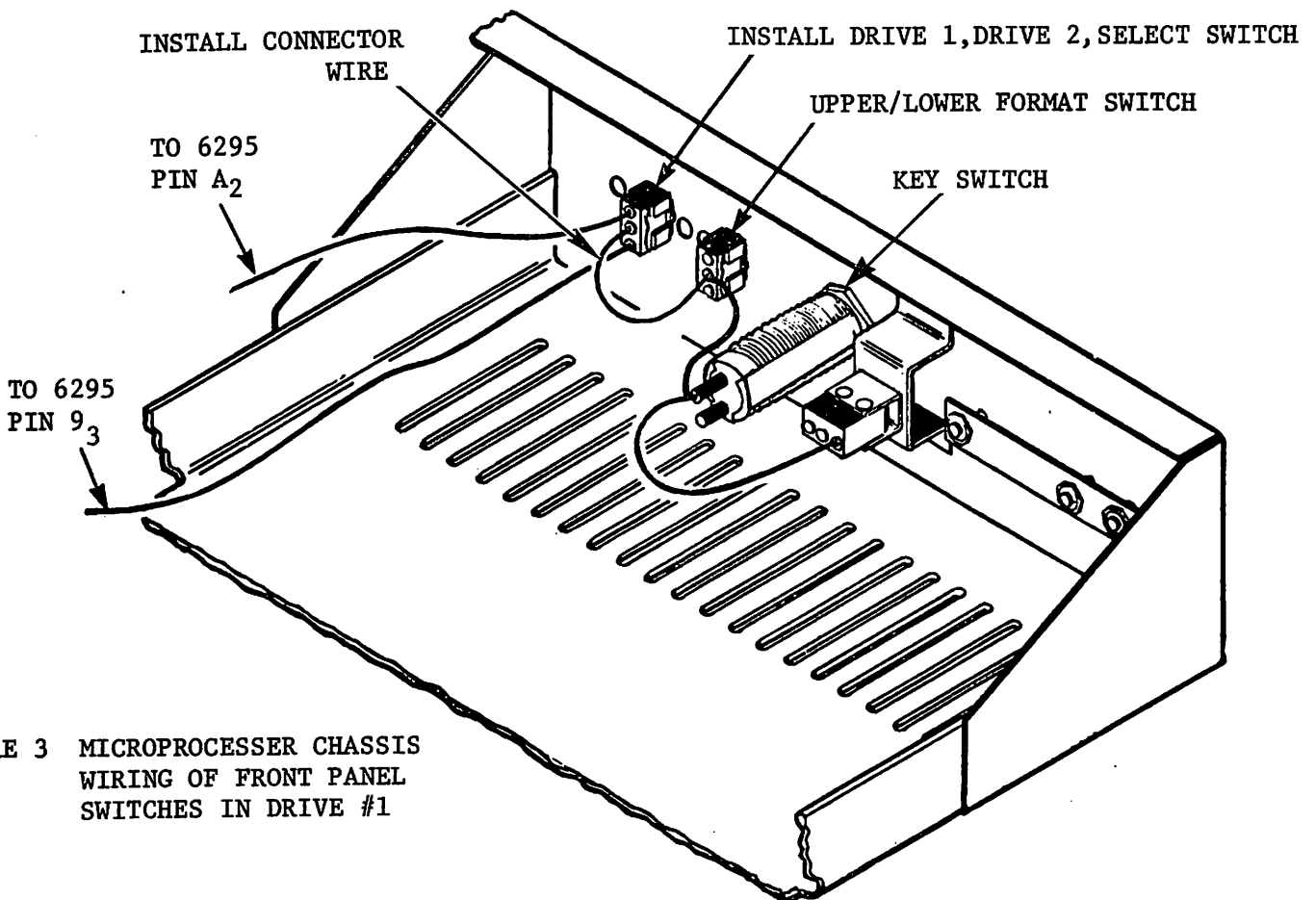
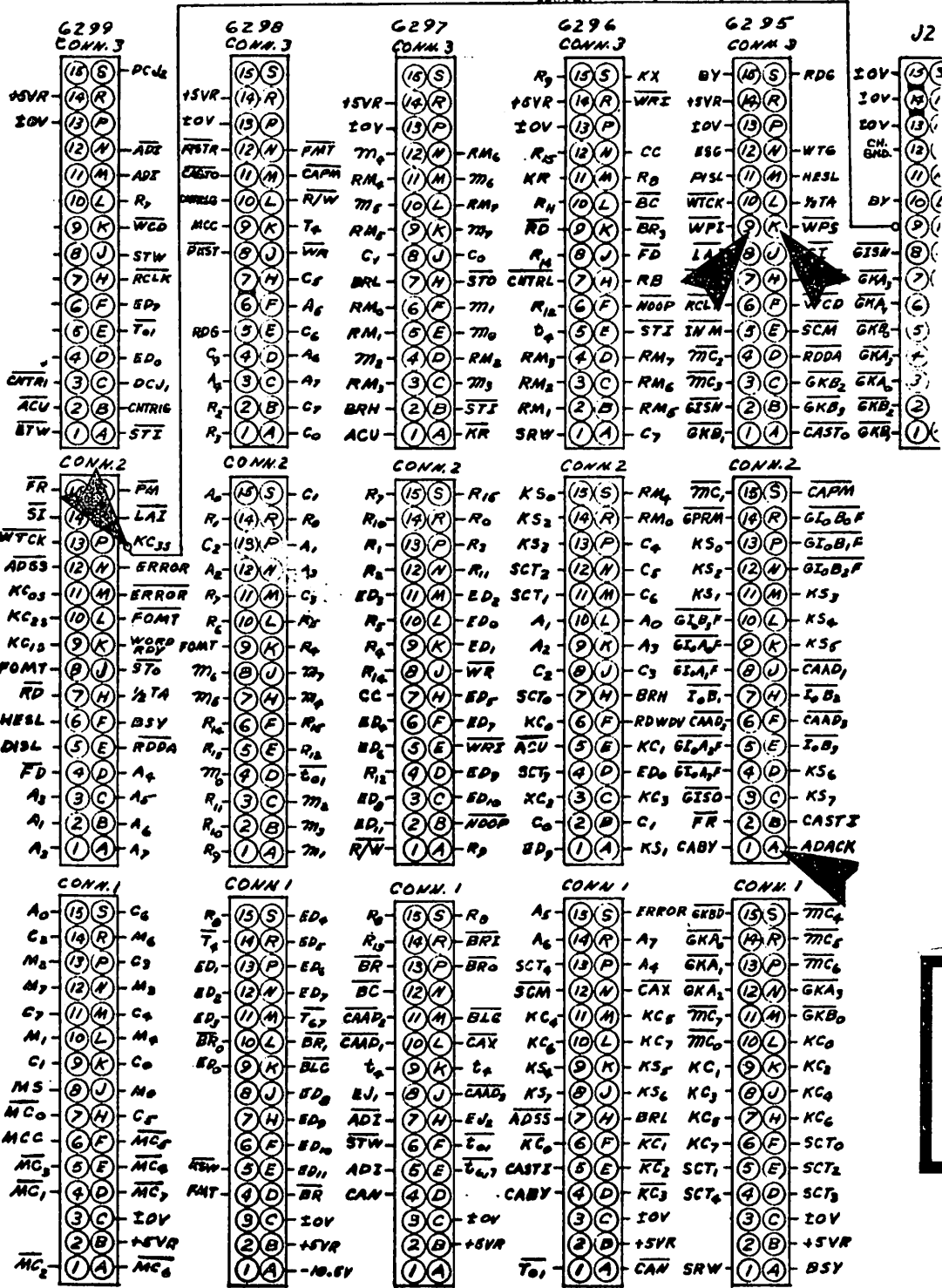

FIGURE 3 MICROPROCESSER CHASSIS
WIRING OF FRONT PANEL
SWITCHES IN DRIVE #1

- c) Connect a wire from the lower contact of the added switch (see Figure 3) to pin 9_3 of the 6295 connector on the 6349 motherboard (Ref: Figures 4 and 5).
- d) Connect a black wire from the center contact of the added switch to the center contact of the Fixed/Removable Disk Select Switch (Figure 3).
- e) Connect a wire from the upper contact of the added switch to pin A_2 of the 6295 connector on the 6349 motherboard (Figures 3, 4 and 5).
- f) On 6349 motherboard, remove the wire from pin P_2 of the 6299/6398 connector (Figures 4 & 5).
- g) Solder the end of the wire just removed in step (f) to pin K_3 of the 6295 connector on the 6349 motherboard (Figures 4 & 5).
- h) Remove 6295 and install 6295-1 (supplied in kit) in its place.
- i) Remove the ribbon cable from Drive #1 and replace it with the modified cable (WL #220-0150) also supplied in the kit.
- j) Remove the 6398 and implement ECN 5692. Increment the E-Rev to 2 (Figure 6).
- k) Remove the front panel from Drive #1 (Master) and replace it with the Master front panel supplied in the kit.
- l) Install the modified Master microprocessor chassis in Drive #1.
- m) Remove the Terminator cover from rear panel of Drive #2 (Slave).
- n) Change the SELECT plug from position 1 to position 2 (Figure 2).

- o) Replace the Terminator (Drive #2) cover and install the terminator.
- p) Between drives #1 and #2, connect the cable (220-0151) supplied in the kit.
- q) Connect the I/O cable from Drive #1 (Master) to the Disk I/O Controller in the 2200 CPU.
- r) Secure the disk cabinets together with the connecting plate (WL #451-1255) supplied.

(SEE NOTE 2)
JUMPER FOR MODEL 2260



WANG LABORATORIES INC.
TELEPHONE: 617-252-1111
FAX: 617-252-1111
ADDRESS: 2250 WASHINGTON ST., BOSTON, MA 02118
MODEL: 6349
MOTHER BOARD AND POWER SUPPLY
SERIAL: 6349-1

NOTES
1. SIGNALS - KC05, KC25, KC35 AND AD55 ARE NOT USED ON ALL 2260 MODELS.
2. OF J2 TO P3 OF CONN. 6299

INSTRUCTIONS:
1) REMOVE JUMPER FROM PIN P3 OF 6298/6299 CONN. AND REFER TO PIN P3 OF 6295 CONN.
2) CONNECT WIRES FROM DISK 1/DISK 2 SELECT SWITCH TO PINS 9, AND A OF 6295 CONNECTOR PER FRONT PANEL IDENTIFICATION DIAGRAM.

FIGURE 4 - MICROPROCESSOR MOTHERBOARD (6349; ECN 5657)

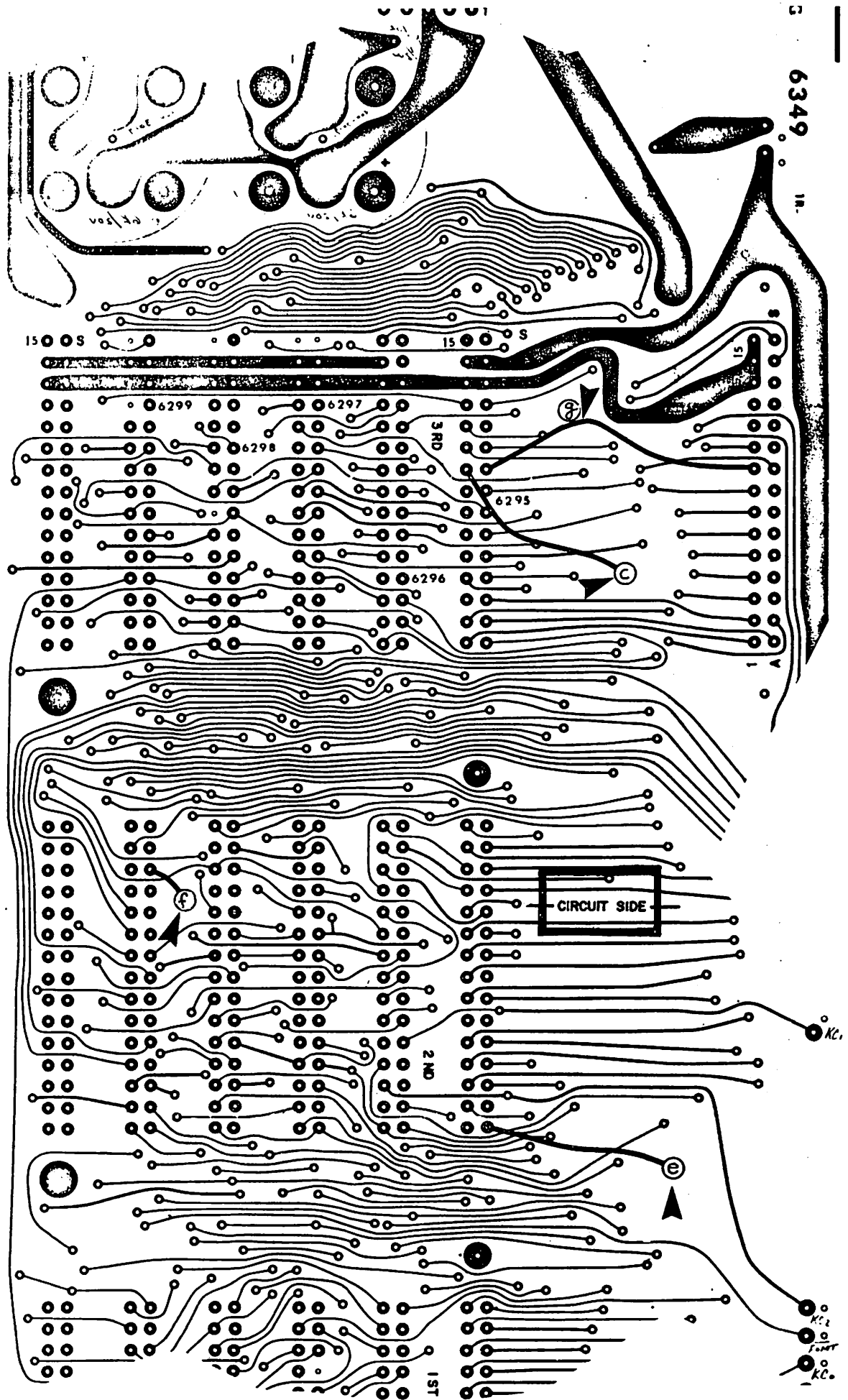

FIGURE 5 - 6349; ECN 5657

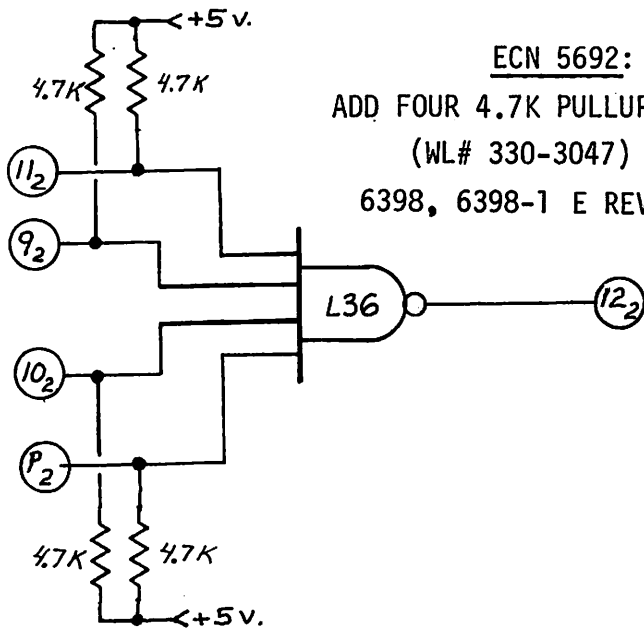

FIGURE 6 - ECN 5692; 6398/98-1 PC

3. SYSTEM OPERATION & TESTING

- a) Apply power to all units. Both drives should show a 'READY' light after two minutes.
- b) Format the platters by selecting the Drive Format and Fixed/Removable Format Switches (4 format operations; 2 for each disk).
- c) Verify access to all four platters by standard disk operations (i.e., DATALOAD, LIST, etc.) at the controller address and at that address plus HEX 40.
- d) Load appropriate disk diagnostics and verify proper operation.

4. CIRCUIT BOARD CHANGES

The following ECN's were implemented in order to adapt microprocessor circuit boards for the 20 Megabyte Disk System.

On the wire side of the 6295 Terminator PC Board: (Figure 7; ECN 5656.)

- a) Connect a wire from L1 pin 2 to L1 pin 13.

On the component side of the 6295 (Figures 8 and 9; ECN 5656):

- b) Connect a wire from L1 pin 1 to L17 pin 4.
- c) Connect a wire from L1 pin 13 to the junction of R152 and R151.
- d) Connect a wire from L1 pin 12 to the junction of R153 and R154.
- e) Cut the etch which connects L17 pin 3 to the junction of R153 and R154.
- f) Cut IC pin #8 of L12. Do not cut the etch connecting to L12 pin 8.
- g) Replace R126 (2.2K) with a 1K Ω , 1/4W, 10% resistor WL #330-3010.
- h) Connect a wire from connector pin A₂ to etch from L17 pin 3.
- i) Change the 6295 identification to 6295-1.
- j) Implement ECN 5692 on the 6398 (Figure 6).

On the 6580 I/O Board: (Figure 10.)

- k) Cut etches in four places as shown.
- l) Connect a wire from J3 pin R to J2 pin 10; from J3 pin L to J2 pin 9; from J3 pin r to platethru above J1, pins 34 and 35.

NOTE:

Normally, a 6351 pc (identically modified) is used instead of a modified 6580 pc.

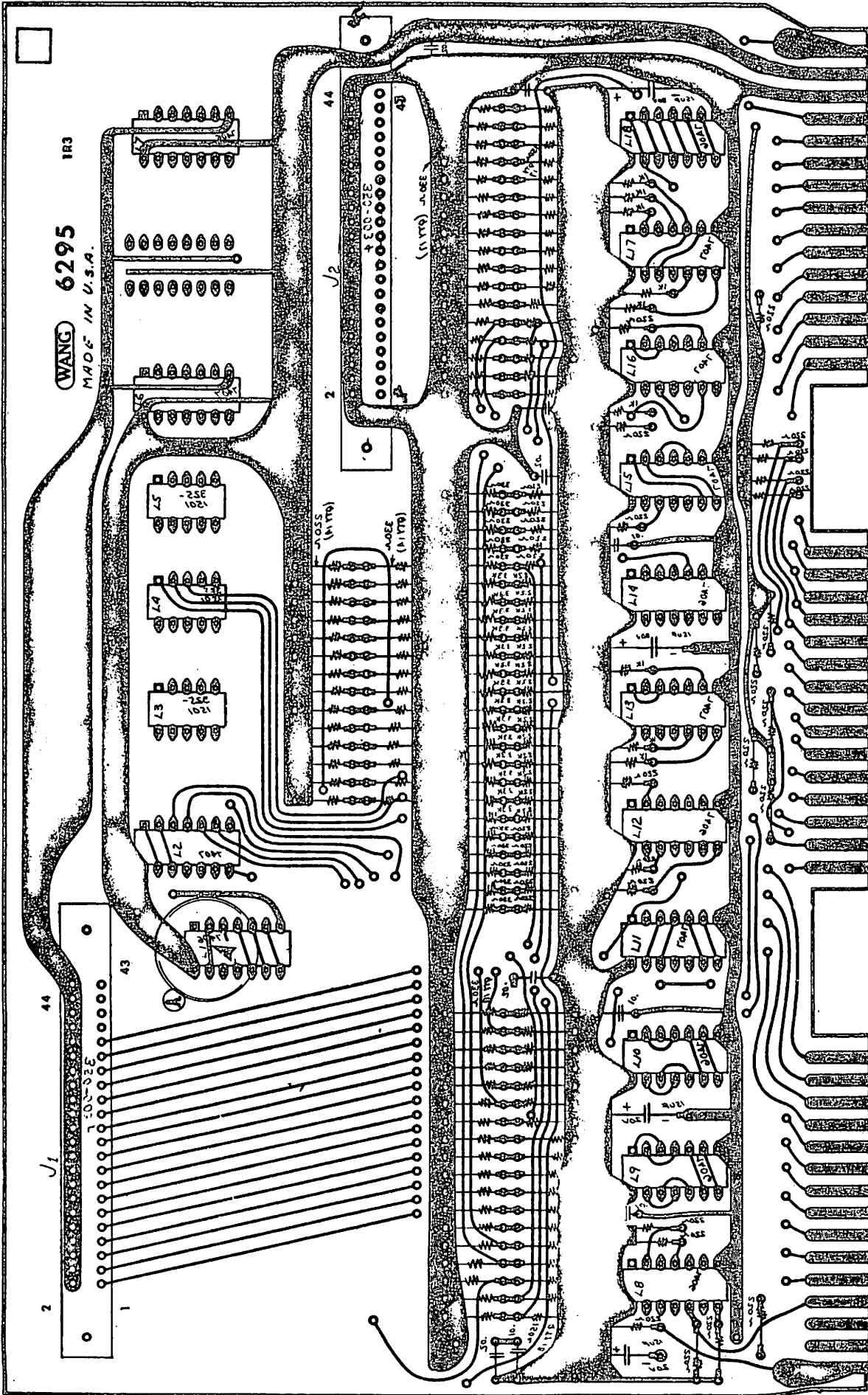

COMP SIDE
AFTER MODIFICATION

COMP SIDE

J1

2

1R3

6995

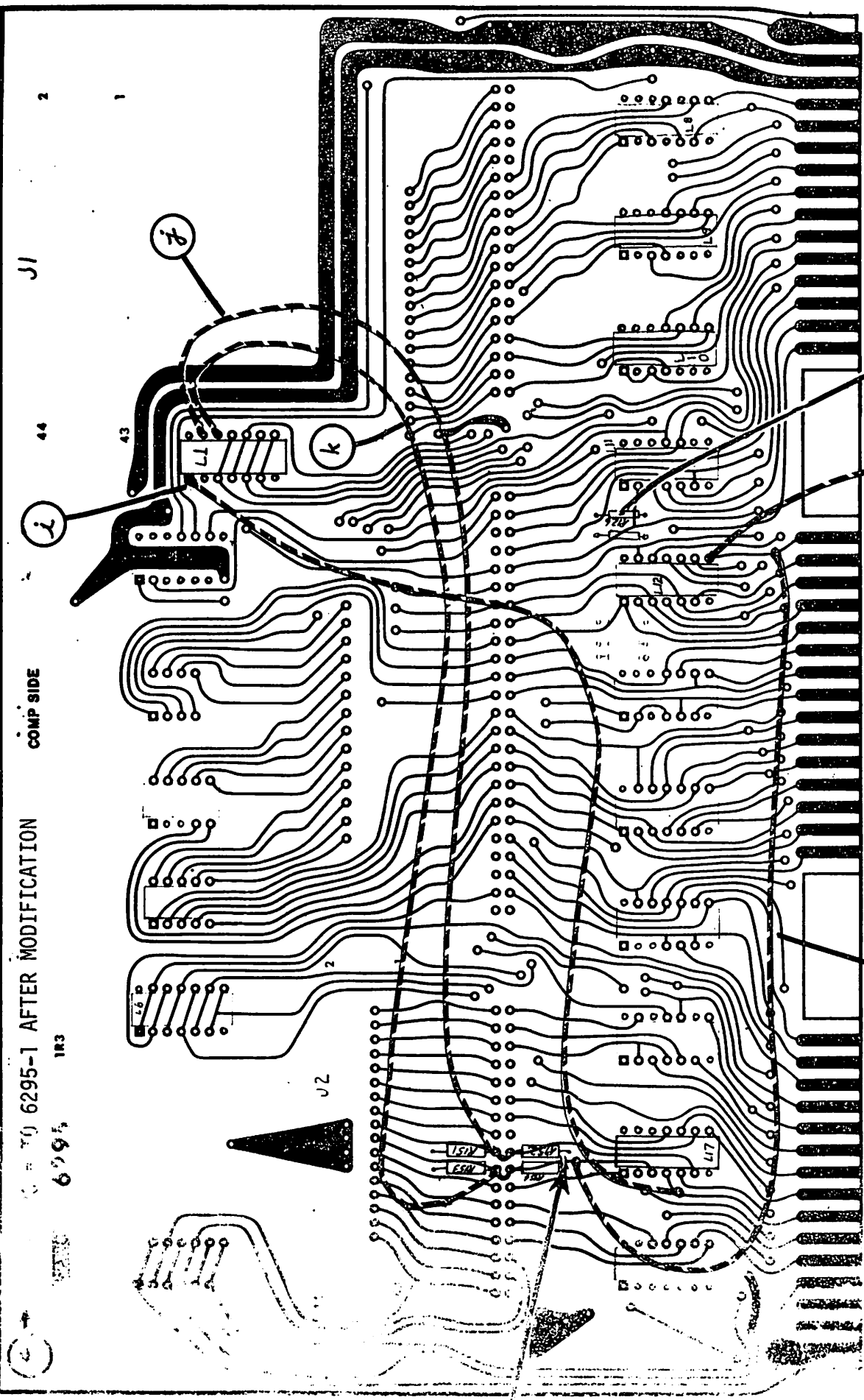

i

j

k

l

m

n

o

p

q

r

s

t

u

v

w

x

y

z

AA

AB

AC

AD

AE

AF

AG

AH

AI

AJ

AK

AL

AM

AN

AO

AP

AQ

AR

AS

AT

AU

AV

AW

AX

AY

AZ

BA

BB

BC

BD

BE

BF

BG

BH

BI

BJ

BK

BL

BM

BN

BO

BP

BQ

BR

BS

BT

BV

BW

BX

BY

BZ

CA

CB

CC

CD

CE

CF

CG

CH

CI

CJ

CK

CL

CM

CN

CO

CP

CQ

CR

CS

CT

CV

CW

CX

CY

CZ

DA

DB

DC

DD

DE

DF

DG

DH

DI

DJ

DK

DL

DM

DN

DO

DP

DQ

DR

DS

DT

DV

DW

DX

DY

DZ

EA

EB

EC

ED

EE

EF

EG

EH

EI

EJ

EK

EL

EM

EN

EO

EP

EQ

ER

ES

ET

EV

EW

EX

EY

EZ

FA

FB

FC

FD

FE

FF

FG

FH

FI

FJ

FK

FL

FM

FN

FO

FP

FQ

FR

FS

FT

FV

FW

FX

FY

FZ

GA

GB

GC

GD

GE

GF

GG

GH

GI

GJ

GK

GL

GM

GN

GO

GP

GQ

GR

GS

GT

GV

GW

GX

GY

GZ

HA

HB

HC

HD

HE

HF

HG

HH

HI

HJ

HK

HL

HM

HN

HO

HP

HQ

HR

HS

HT

HV

HW

HX

HY

HZ

IA

IB

IC

ID

IE

IF

IG

IH

II

IJ

IK

IL

IM

IN

IO

IP

IQ

IR

IS

IT

IV

IW

IX

IY

IZ

JA

JB

JC

JD

JE

JF

JG

JH

JI

JJ

JK

JL

JM

JN

JO

JP

JQ

JR

JS

JT

JV

JW

JX

JY

JZ

KA

KB

KC

KD

KE

KF

KG

KH

KI

KJ

KK

KL

KM

KN

KO

KP

KQ

KR

KS

KT

KV

KW

KX

KY

KZ

LA

LB

LC

LD

LE

LF

LG

LH

LI

LJ

LK

LL

LM

LN

LO

LP

LQ

LR

LS

LT

LV

LW

LX

LY

LZ

MA

MB

MC

MD

ME

MF

MG

MH

MI

MJ

MK

ML

MM

MN

MO

MP

MQ

MR

MS

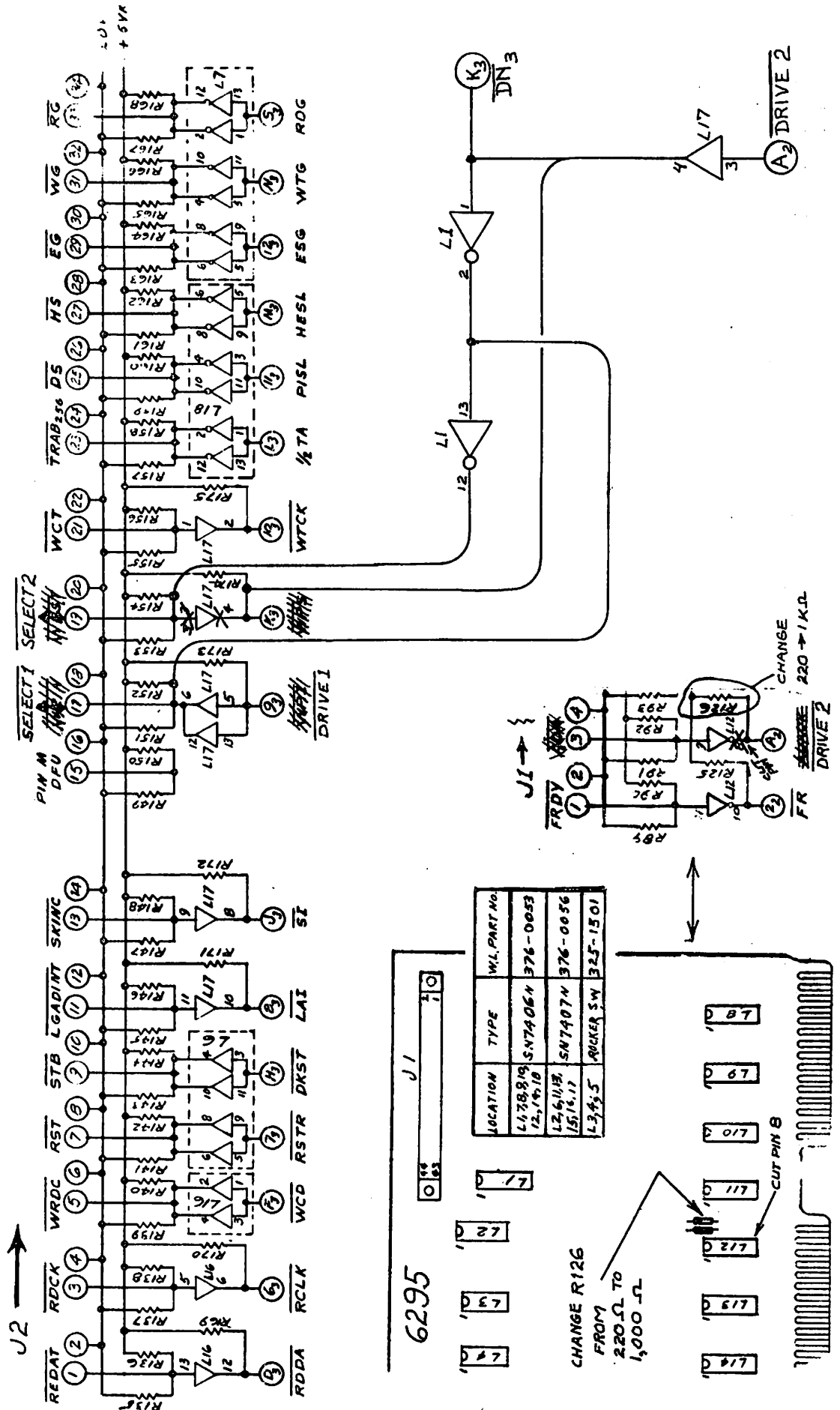

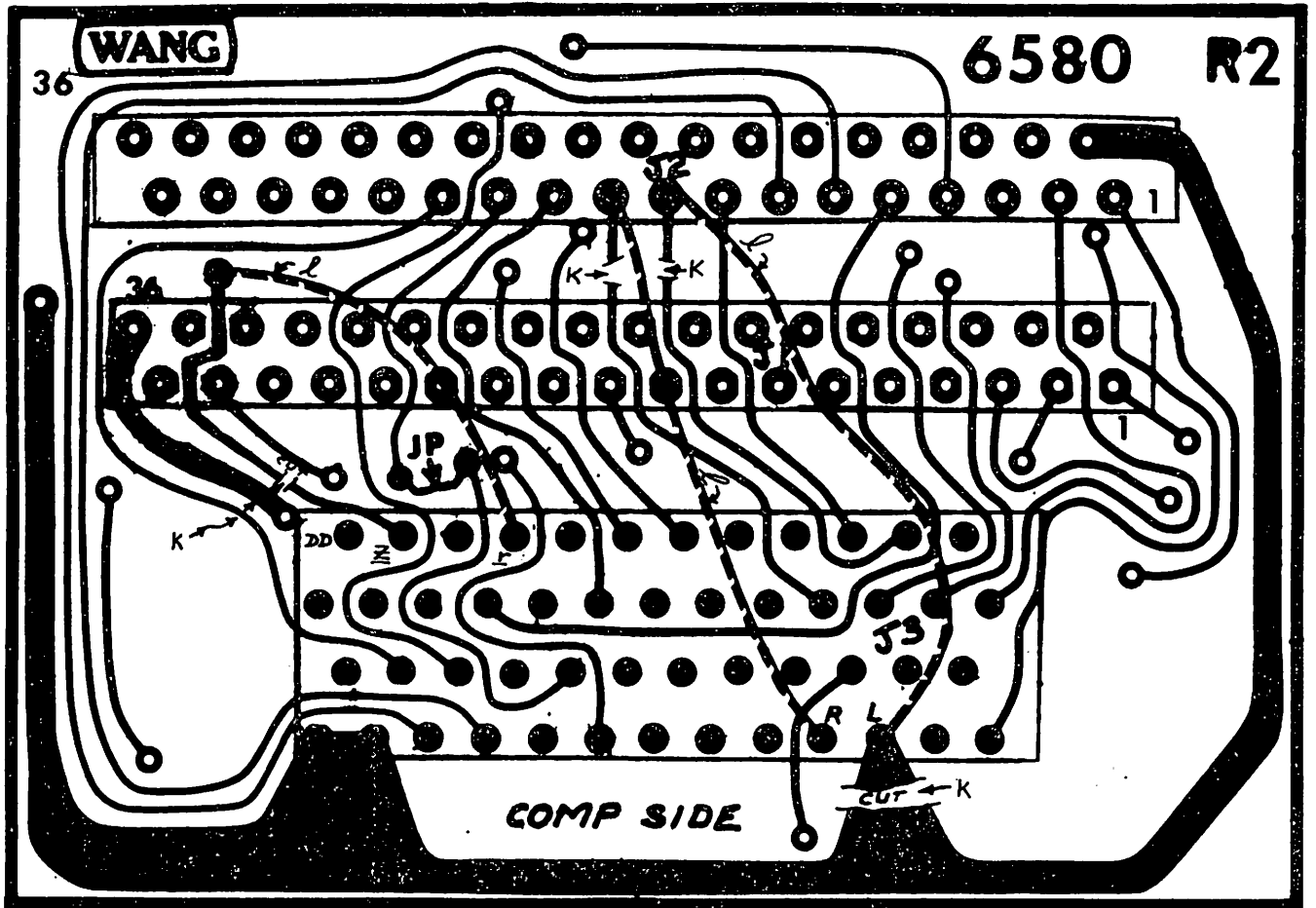

 <p>IMMEDIATE SERVICE NOTICE</p>	NO. 136	DATE: 4/13/77
	CATEGORY	
	MASS STORAGE DEVICES #7	
SUBJECT		
MODELS 630/730/2230/2260/2260B NEW DISK INTERFACE CABLE		

The interface cable (WLI #220-0108-1) used between the Diablo disk drive and the WANG microprocessor is being replaced by a similar ribbon cable (WLI #220-0108-2) that has the terminator incorporated as part of the cable. The 6580 PCB is replaced by a 7080 PCB to accommodate the addition of the terminating resistors. A jumper is provided on the 7080 PCB to select the additional address bit required for 2260 operation (see Figure on other side). The jumper must be in for 2260 use and out for 2230 use.

The transition to this new cable creates a problem since the 7013 exerciser requires a terminator to operate properly. This means that each office must have a terminator available for disk service calls. Due to a shortage of Diablo terminators, the Home Office cannot supply enough terminators as required. To relieve this situation, it is suggested that the interface cable in older units be replaced with the new interface cable to acquire the terminator(s) from customer units.

NOTE:

These cables (-0108-1 and -0108-2) cannot be used with the disk drive that is part of the 928 System 30; this part number is 220-0108-3.

The 928 disk cable is longer and the 7080 board is modified for 928 use. This configuration is temporary until a new board is manufactured to replace the modified 7080 in 928 Systems.



LABORATORIES, INC.

1 INDUSTRIAL AVENUE, LOWELL, MASSACHUSETTS 01851. TEL (617) 851 4111, TWX 710 343-6769, TELEX 94 7421

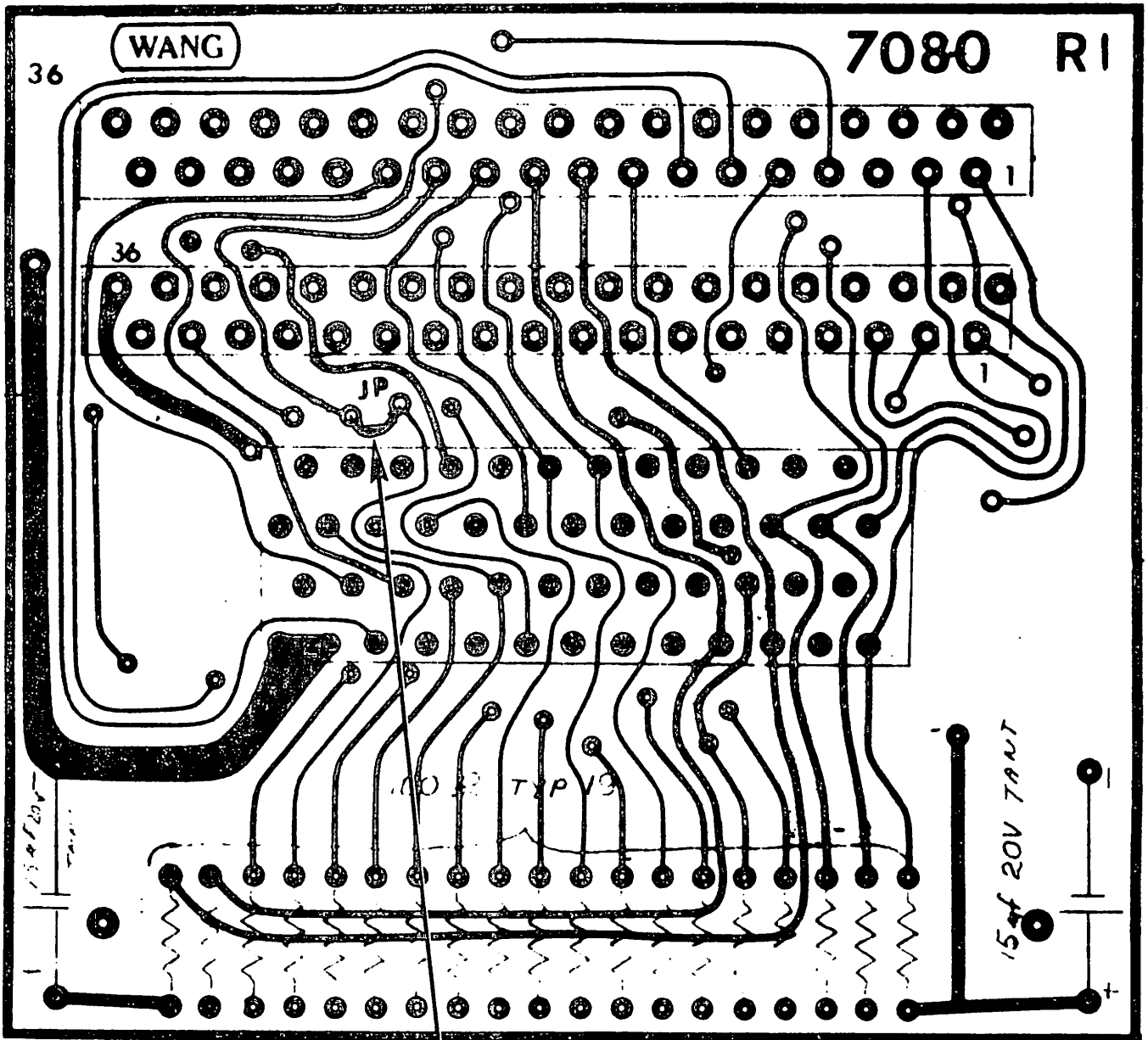

JUMPER WIRE

2260/2260B/2260B½/2260B¼ - INSERT

630/730/2230 - REMOVE



NO. 113

DATE: 5/24/75

ITEM(S) / PRODUCT(S):

SYSTEM 2200 #1

TRIPLE CONTROLLER ARTWORK ERRORS

An artwork error on the 6742 and the 7042 triple controller can cause a Model 2260 disk to 'hang up' while performing certain operations e.g. LIST, COPY, MOVE, etc.

This problem is corrected by the following ECN's.

PC BOARD	ECN	FROM E REV	TO E REV
6742	5562	3	4
6742-1	5562	3	4
7042	5563	2	3
7042-1	5563	2	3

To perform the above ECN's on component side of board:

1. Cut etch at J3 Pin 29 between connector pin and the plate through.
2. Add jumper from J3 Pin 29 to J3 Pin 33 (+0V).

WANG

LABORATORIES, INC

436 NORTH STREET, TEWKSBURY, MASSACHUSETTS 01876 TEL (617) 851-4111, TWX 710 343 6769, TELEX 94 7421

Printed in U.S.



NO. 103

DATE: 1/20/76

ITEM(S) / PRODUCT(S):"2230 MXA/B MULTIPLEXER SYSTEM
MODIFICATIONS"

Due to the numerous problems with the 2230 Multiplexer System (2230 MXA/B), extensive research was done on the multiplexer design. This resulted in several ECNs, and hopefully, a final solution to 2230 MXA/B disk multiplexer problems.

It is apparent that some of these ECNs have not been implemented on all multiplexers; therefore, all applicable ECNs are listed in this ISN in ascending chronological order. Ensure that each of the ECNs listed are incorporated; some of these ECNs are interactive.

Proceed as follows:

A) MODEL 2230 MXA (MASTER CONTROLLER); 6785 PC

CHANGE #1: ECN #5089

This ECN was performed on all multiplexers prior to shipment from the plant.

CHANGE #2: ECN #5111

Change the .001 μ f ceramic capacitor connected between L15 pin 2 and +0 volts to .002 μ f ceramic (WL #300-1913).

CHANGE #3: ECN #5162

On the component side, connect a 4.7 K Ω , 1/4 W., 10% resistor (WL #330-3047) between L14 pin 11 and +5 volts. Next,

WANG

LABORATORIES, INC

436 NORTH STREET LEWISBURG, MASSACHUSETTS 01876 TEL (617) 851-4111, TWX 710 343 6769, TELEX 94 7421

2230 MXA
MASTER CONTROLLER
6785 PC

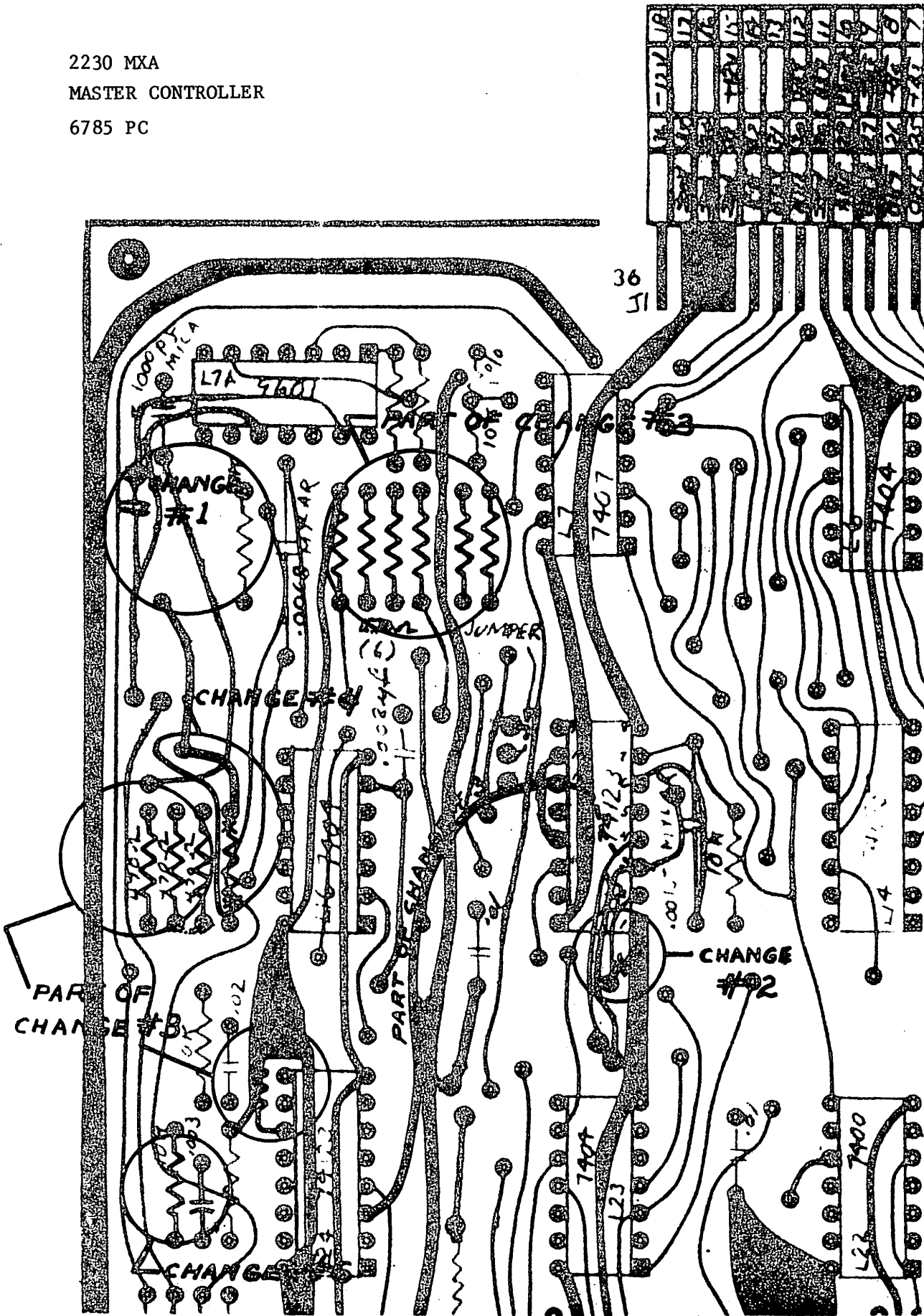

2230 MXA
MASTER CONTROLLER
6785 PC

(WITH ALL CHANGES, ELEC. REV. LEVEL = 6)

6	5	4	3	2	1
19	18	17	16	15	14
13	12	11	10	9	8
7	6	5	4	3	2
1	2	3	4	5	6

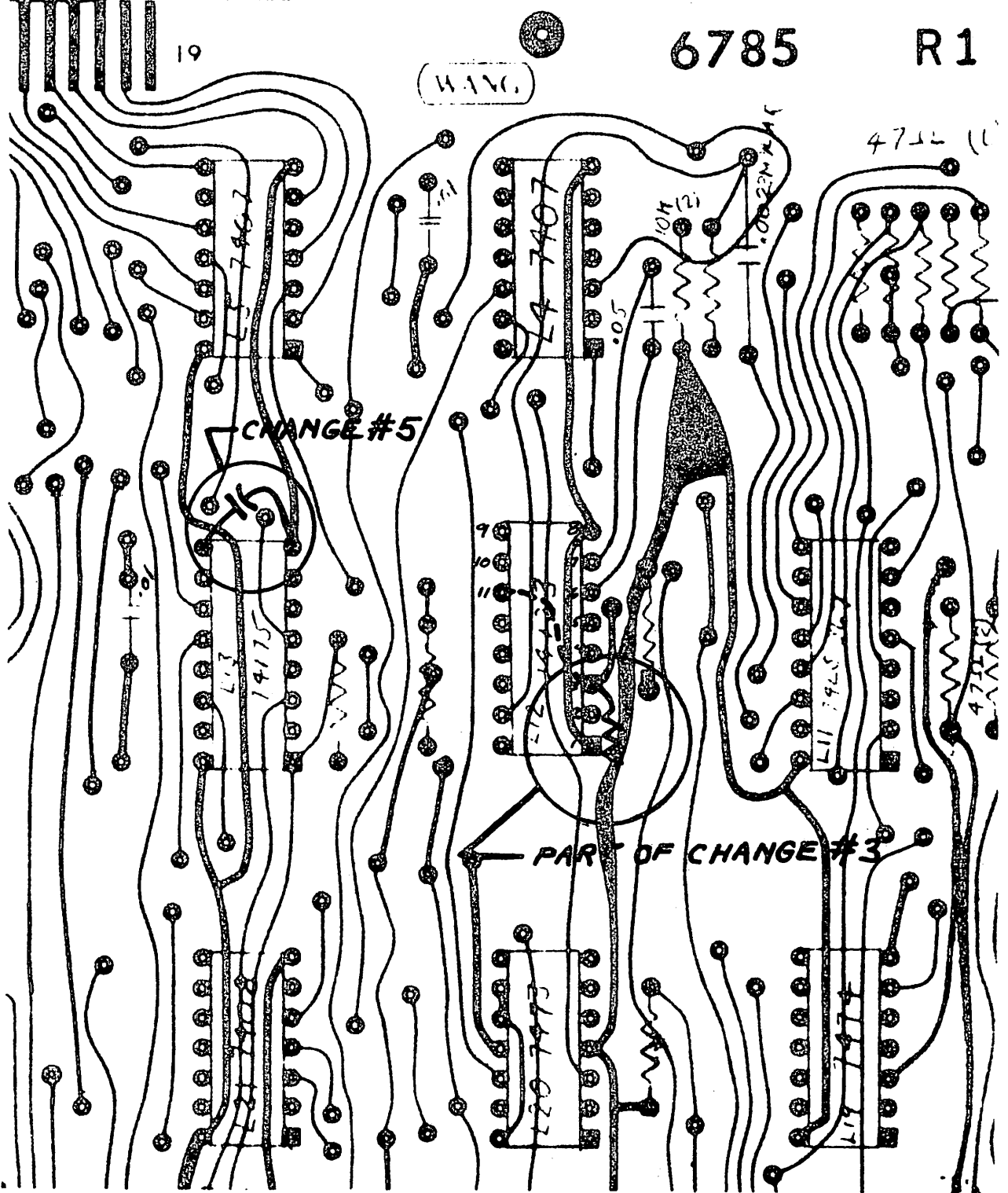

connect a wire from L15 pin 11 to L24 pin 3. Connect another 4.7 K Ω , 1/4 W., 10% resistor from L12 pin 3 to +5 volts. Change resistors R12 thru R20 from 4.7 K Ω to 470 Ω , 1/4 W., 10%.

On the wire side, connect a wire from L15 pin 3 to L15 pin 11. Connect another wire from L24 pin 3 to L24 pin 11. Lastly, connect a wire from L12 pin 3 to L12 pin 11.

This ECN changes the Electronic Revision Level from 2 to 3.

CHANGE #4: ECN 5190A

Connect a wire from L16 pin 9 (BSY) to +0 volts. Remove R63.

This ECN changes the Electronic Revision Level from 3 to 4.

CHANGE #5: ECN #5284

Add a .0068 μ f ceramic capacitor (WL #300-1911) between L13 pin 9 and +0 volts.

This ECN changes the Electronic Revision Level from 4 to 5.

CHANGE #6: ECN #5318

Change R45, located at L24 pin 15, from 10 K Ω , 1/4 W., 10% to 22 K Ω , 1/4 W., 5% (WL #330-4023). Next, change C6 from .003 μ f ceramic, to 1,000 pf. mica (WL #300-5006).

This ECN changes the Electronic Revision Level from 5 to 6.

B) MODEL 2230 MXB (SLAVE CONTROLLER); 6786 PC

CHANGE: ECN #5319

Change R11, located at L1 pin 11, from 12 K Ω , 1/4 W., 10% to 10 K Ω , 1/4 W., 1% (WL #333-0017). Change C1 from .0015 μ f ceramic to 1,000 pf. mica (WL #300-5006).

This ECN changes the Electronic Revision Level from 0 to 1.

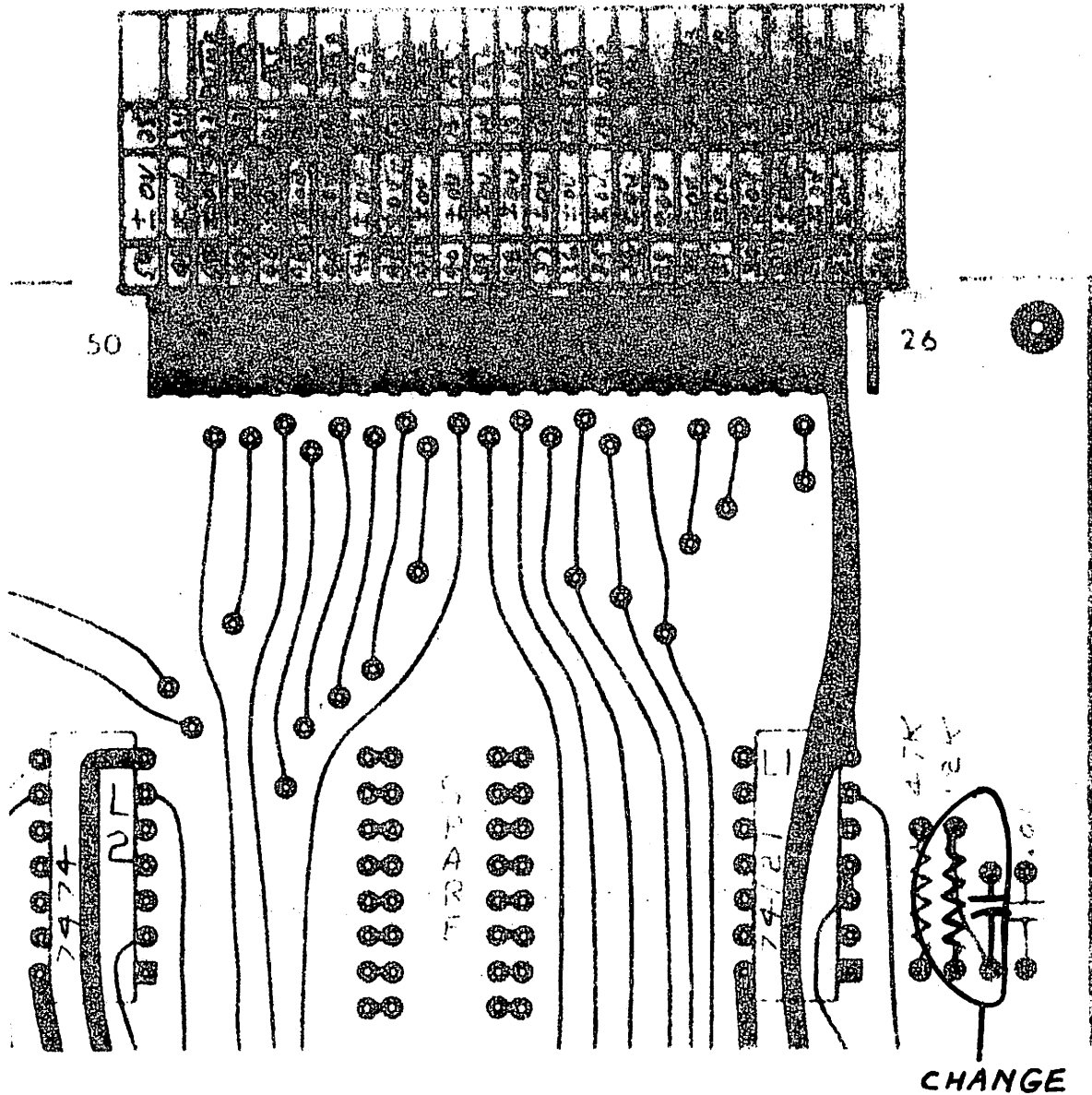

2230 MXB - SLAVE CONTROLLER

6786 RO

(CHANGES ELEC. REV. LEVEL FROM 0 TO 1)



**IMMEDIATE
SERVICE
NOTICE**

NO. 31

DATE: 11/20/74

ITEM(S) / PRODUCT(S):

MDL 2260 TEN MEGABYTE DISK UNIT

NEW PRODUCT:

1. GENERAL:

The WANG Model 2260 Ten Megabyte Disk unit is a 200 track-per-inch (200 TPI) Diablo Model 44 disk drive, combined with a WANG Microprocessor. The data storage capacity doubles that of the Model 2230-3 (a total of 10,027,008 bytes are available on the 2260). As with the 2230, storage allocation is evenly distributed between a fixed disk and a removable disk.

With fast rotational speed (2400 rpm) and high track density (200 TPI) of the Diablo model 44 combined, the WANG 2260 yields an average access time of 38 ms; the total number of sectors is 39,168 (19,584 sectors per disk).

2. HARDWARE DIFFERENCES:

The 2230 and 2260 are very similar. Most of the PC board compliment for both the Diablo Model 44 Disk Drive and the WANG 2260 microprocessor unit is compatible with WANG 2230 units. (Slight modifications to 2230 PC boards are necessary.)

The major difference between 2230 and 2260 units appear in the Head Positioner and Head Assemblies: Due to a lower track-per-inch density, the Head Positioner for the 2230 (Diablo part number 16010-10) does not meet the same specifications for track linearity that the 2260 head positioner does (Diablo part number 16010-20). (Tracks are twice as wide on the 100 TPI 2230, as they are on the 200 TPI 2260.) The magnetic pickup heads in the 2230 (Diablo #16272-03 or -04) are 7 mils wide; 2260 heads (Diablo #16272-05 or -06) are 3.5 mils wide.

2.1 2230/2260 PC BOARD COMPATIBILITY

The following tables list PC boards used in a 2230, and the changes which are required for use in a 2260. Table 1 covers the Diablo Disk Drive; Table 2, the WANG Microprocessor.

WANG

LABORATORIES, INC

836 NORTH STREET, NEWBURY, MASSACHUSETTS 01876. TEL (617) 851 4111, TWX 710 343 6769, TELEFAX 94 7421

Printed in U.S.

TABLE 1 - (Continued)

WANG 2230 (Diablo Model 43) Designation/ Diablo #:	WANG 2260 (Diablo Model 44) Designation/ Diablo #: Changes:	
AW-CB 11435-20	AW-CB 11435-20	No changes; directly compatible
I01-CB 11431-01 or RDR1-CB 11643-01	I01-CB 11431-01 or RDR1-CB 11643-01	No changes; directly compatible.
I02-CB 1433 or RDR2-CB 11645-00	I02-CB 11504 or RDR2-CB 11647-00	11504 (new board) is not compatible with 11433. 11647-00 (new board) is not compatible with 11645-00.
D/CS-CB 11429-00 11637-00	D/CS-CB 11429-01 11429-01 11637-01	11429-01 are not compatible with: 11637-01 11429-00 or 11637-00
SC-CB 11459	SC-CB 11459	No changes; directly compatible.
IO-MB 11400-01 11521	IO-MB 11400-01 11521	No changes; directly compatible.
TC-CB (NOT USED IN DIABLO MOD. 43)	TC-CB 11537	Not interchangeable between 2260's; requires unique calibration for temperature compensation.

TABLE 2 - WANG MICROPROCESSOR PC BOARDS

2230 Micro-processor/WL#	2260 Micro-processor/WL#	Changes:
6295 PC #210-6295	6295 PC #210-6295	No changes; directly compatible.
6296 PC #210-6296	6296 #210-6296	No changes; directly compatible.
6297-1 PC #210-6297-1 or 6597* #210-6597	6297-1PC #210-6297-1 or 6597* 210-6597	Both 6297 and 6597 must be changed as follows, for use of either PC in a 2260. Cut etches from L14-11 and from L2-3. Add a jumper wire from L24-2 to L2-2. Add another jumper wire from L1-13 to L2-3.
6298 PC #210-6298	6298 PC 210-6298	Must insert PROMs for 2260. See loading diagram, page 6.
6299 210-6299 or 6398 210-6398 6.25 MHz XTAL	6299 210-6299 or 6398 210-6398	To use either 6299 or 6398 in 2260, change 6.25 MHz XTAL to 10 MHz XTAL.
341 PC 210-0341	341 PC 210-0341	No changes; directly compatible.
6349 (Motherboard)	6349	Add a jumper wire from 6299 socket pin 9 ₂ to I/O connector pin 9.

*See NOTE, page 5.

NOTE:

The 6297-1 PCB will be superceded by a 6597 PCB in the near future. The 6597 will be a universal board for use with all disks except the 740. The jumpers presently incorporated in the 6297-1 at locations L16, L17 and L18 will be replaced by etches on the 6597.

The interface cable (WL #220-0108) between the Diablo disk drive and the WANG microprocessor will be phased out and superceded by a ribbon-type cable (WL #220-0108-1; see Figure below). This new ribbon cable will have provisions for a jumper wire insertion between two plate-through eyelets, located on the backside of the 6580 connector board PC. This jumper wire *must* be installed when the ribbon cable is used in a Model 2260. This jumper should be *removed* from the 6580 connector PC, for use of a ribbon cable in the 2230-1, -2, or -3. The previous cable (WL #220-0108) can also be used on a 2260 by *adding* a spare wire from J2 finger-board connector pin 23 to Winchester connector pin small "m".

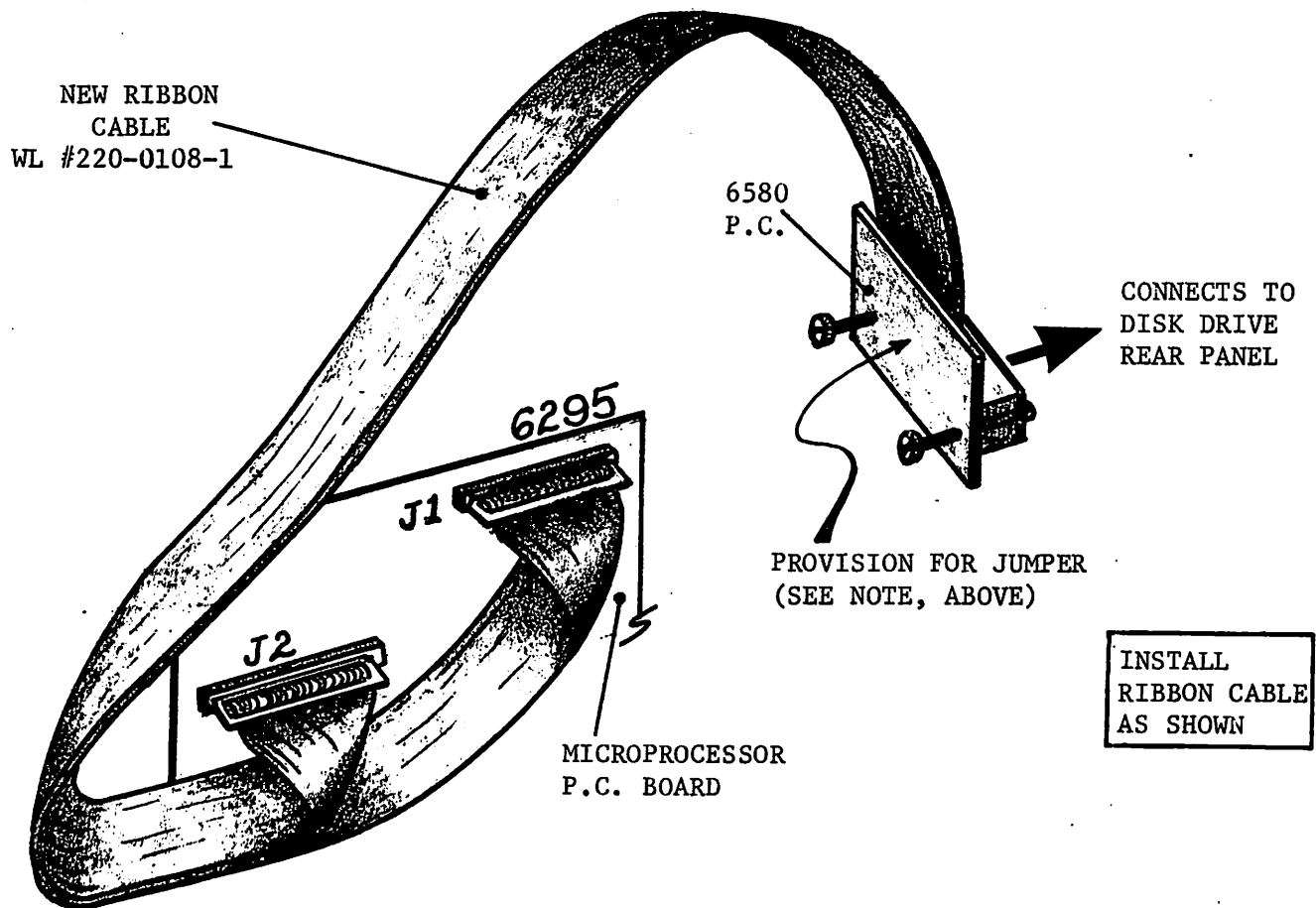

2.2 PROM LOADING OF 6298 PC - 2260

On the 6298 PCB there has been a recent ECN (#4464). This ECN *must* be complied with before the 6298 PCB can be used with a 2260; however, the ECN pertains to all 6298 PC boards.

Change R8 (1K 1/4W) to a 2.7K 1/4W resistor (330-3027) and change C3 (.003 μ f ceramic capacitor) to a .001 μ f mylar capacitor (300-2010). See Schematic Manual.

6298 PROM loading for 2260 is as follows:

L8	L7	L6	L5	L4	L3	L2	L1
378- 0359	378- 0357		378- 0361	378- 0358	378- 0356		378- 0360

6298 PC

3. DISK CARTRIDGES

3.1 REMOVABLE CARTRIDGES

Removable disk cartridges presently being used (WL #177-0041) are not certified for 200 TPI use. Some of these cartridges have a 200 TPI stamp. These "200 TPI" stamped disks are also not certified for Customer use. The 200 TPI cartridges presently in the field are only certified for a maximum of 400 tracks. The 2260 uses 408 tracks. In the future, Nashua Corp. will certify all 408 track disks. The new Wang part number for these cartridges will be WL #177-0062.

3.2 ALIGNMENT CARTRIDGES

Head alignment and Index alignment are covered in the Diablo Maintenance Manual for the 200 TPI, 2400 RPM Model 44 Disk Drives. These adjustments must be done with a Diablo alignment cartridge. After comparing the CDC alignment cartridges against the Diablo CE pack (P.N. 70709) it has been determined that Diablo CE packs will be ordered for the Model 44 disk drive alignments. These CE packs will be sent to area offices as soon as they are received from Diablo, Inc. A detailed description of these alignments will be covered in a future bulletin.

4. 2260 SOFTWARE DIFFERENCES

The 2260 uses the same BASIC statements that the 2230-1, -2 and -3 uses. From a software point of view, the only difference is an increased number of available sectors. The highest address for both fixed and removable 2260 disks is 19,583 as compared with 2399, 4799, and 9791 for the 2230-1, -2 and -3, respectively.

5. 2230/2260 DIAGNOSTICS

5.1 2230/2260 DISK HARDWARE DIAGNOSTICS

This diagnostic is very similar to the 2230 Disk Hardware Diagnostic. It can be used on both the 2230 and the 2260 models.

INSTRUCTIONS

- 1) CLEAR, EXECUTE.
- 2) LOAD, EXECUTE.
- 3) RUN, EXECUTE.
- 4) The CRT displays the following:
ENTER 1, 2, 3, or 4.

1 - - - - - 2230-1 Disk Drive
2 - - - - - 2230-2 Disk Drive
3 - - - - - 2230-3 Disk Drive
4 - - - - - 2260 Disk Drive
- 5) ENTER Y or N for the first test. This test is long, and may be skipped and returned to later.

This diagnostic checks the following:

- (a) WRITES and READS on every sector.
- (b) DATASAVE DA/DATALOAD DA using 1 to 10 variables.
- (c) DATASAVE DA/DATALOAD DA using Alphanumeric variables.
- (d) DATASAVE DA/DATALOAD DA using Alphanumeric arrays.
- (e) DATASAVE BA/DATALOAD BA using Numeric and Alpha.
- (f) Numeric Sector Addressing.
- (g) READ after a WRITE.

Hardware diagnostics yield the following results:

TEST A: FIXED DISK.
 ERRORS = X Y.Z%

REMOVABLE DISK:
 ERRORS = X Y.Z%

Where: X = Quantity of errors
 Y.Z = Percentage; indicates number of sectors failed vs. total number of sectors on the disk under test.

FIXED DISK

Testing DATASAVE DA, DATALOAD DA, using from 1 to 10 variables.

Loop # () Complete ← (1 - 5 loop count)

REMOVABLE DISK

Testing DATASAVE DA, DATALOAD DA, using from 1 to 10 variables.

Loop # () Complete ← (1 - 5 loop count)

TEST C:

FIXED DISK:

Alpha-numeric variables

Loop # () Complete ← (1 - 5 loop count)

REMOVABLE DISK:

Alpha-numeric variables

Loop # () Complete ← (1 - 5 loop count)

TEST D:

FIXED DISK:

Alpha and Numeric Arrays

Loop # () Complete ← (1 - 5 loop counter)

REMOVABLE DISK

Alpha and Numeric Arrays

Loop # () Complete ← (1 - 5 loop counter)

TEST E:

FIXED DISK:

Testing DATASAVE BA, DATALOAD BA, using numeric and alphanumeric sector addressing.

Loop # () Complete ← (1 - 5 loop counter)

REMOVABLE DISK:

Testing DATASAVE BA, DATALOAD BA, using numeric and alphanumeric sector addressing.

Loop # () Complete ← (1 - 5 loop counter)

FIXED DISK:

Read after Write at random locations.

LOCATION #####	TOTAL SECTORS ###
(0 - 19,583)	(1 - 260) count

REMOVABLE DISK:

Read after Write at random locations.

LOCATION #####	TOTAL SECTORS ###
(0 - 19,583)	(1 - 260) counter

When TEST F completes, the cassette automatically rewinds and reloads the first block, to allow continued testing.

NOTE: A failure in tests B through E produces "STOP ERROR" on CRT, and processing halts.

A failure in test F produces ERROR 85 on CRT.

5.2 2230/2260 MICRO-CODE DIAGNOSTICS

This diagnostic is exactly the same as the 2230 MICROCODE Diagnostic except that it has been expanded for the 2260 addresses.

INSTRUCTIONS

- 1) CLEAR, EXECUTE.
- 2) LOAD, EXECUTE.
- 3) RUN, EXECUTE.
- 4) ENTER 1, 2, 3, or 4 for the following:

- 1 - - - - - 2230-1 Disk Drive
- 2 - - - - - 2230-2 Disk Drive
- 3 - - - - - 2230-3 Disk Drive
- 4 - - - - - 2260 Disk Drive

This diagnostic checks the following instructions:

DATALOAD/DATASAVE DC OPEN	MOVE END
DATALOAD/DATASAVE DC	CATALOG INDEX
DATALOAD/DATASAVE DA	SCRATCH DISK
DATALOAD/DATASAVE BA	COPY
DSKIP, DBACKSPACE	MOVE
VERIFY	DATASAVE DC CLOSE
LIMITS	SCRATCH

A test passed prints "OK" on the CRT; a test failure results in "ERROR" on the CRT.

Service Newsletter

NO. 86.1

MASS STORAGE DEVICES #10

May 6, 1977

THIS NEWSLETTER REPLACES SERVICE NEWSLETTER NO. 86
MODEL 2260 SERIES INTRODUCTION

1. INTRODUCTION

The Wang Model 2260 series Fixed/Removable Disk Drives provide a high-capacity, direct-access storage medium for all Wang systems except the 2200A. (However, the System 2200S and WCS/10 require Option-24, the Disk ROM, in order to support a disk.) The Model 2260 series provides up to ten megabytes (10,027,008 total bytes) of on-line storage capacity.

PHYSICAL CHARACTERISTICS

The Model 2260 series Disk Drives each hold a pair of disk platters, one fixed and one removable. The disk drive's total storage capacity is distributed equally between the two platters.

Each disk platter has two recording surfaces, which are divided into a number of concentric circular recording tracks. Every track is, in turn, subdivided into 24 "sectors". A sector is the smallest addressable unit on the disk, and can store 256 bytes of information (program text or data). The sectors on each platter are sequentially numbered, and individual sectors can be directly addressed.

The 2260 series is divided into two basic categories, one having Wang model numbers of 2260, 2260 $\frac{1}{2}$ and 2260 $\frac{1}{4}$ that contain a Diablo Model 44 disk drive, and the second having Wang model numbers of 2260B, 2260B $\frac{1}{2}$ and 2260B $\frac{1}{4}$ that contain a Diablo Model 44B disk drive. See summary chart below.

WANG

LABORATORIES, INC.

ONE INDUSTRIAL AVENUE, LOWELL, MASSACHUSETTS 01851, TEL. (617) 851-4111, TWX 710 343-6769, TELEX 94-7421

Printed in U.S.A.
13-266

DISK DRIVE SUMMARY

WANG MODEL #	CAPACITY (BYTES)	DIABLO MODEL #
2230-1	1,288,800	43
2230-2	2,457,600	43
2230-3	5,013,504	43
2260B ¼	2,457,600	44B
2260B ½	5,013,504	44B
2260B	10,027,008	44B
2260	10,027,008	44
2260 ¼	2,457,600	44
2260 ½	5,013,504	44

2. DISK PLATTER COMPATABILITY

The disk platter compatibility chart below reflects the disk cartridge interchangeability between the various disk drives offered by Wang Labs. Notice that all 2260/2260Bs are capable of reading all 2230 platters (using a special disk address explained after the chart) and that there is complete compatability between 2260 and 2260B platters.

DISK PLATTER COMPATABILITY CHART

A PLATTER CREATED ON A:	CAN BE READ BY A:								
	2230-1	2230-2	2230-3	2260	2260½	2260¼	2260B	2260B½	2260B¼
2230-1	✓	✓	✓	✓**	✓**	✓**	✓**	✓**	✓**
2230-2	✓*	✓	✓	✓**	✓**	✓**	✓**	✓**	✓**
2230-3	✓*	✓*	✓	✓**	✓**	✓**	✓**	✓**	✓**
2260				✓	✓*	✓*	✓	✓*	✓*
2260½				✓	✓	✓*	✓	✓	✓*
2260¼				✓	✓	✓	✓	✓	✓
2260B				✓	✓*	✓*	✓	✓*	✓*
2260B½				✓	✓	✓*	✓	✓	✓*
2260B¼				✓	✓	✓	✓	✓	✓

*The platter can be read up to the maximum address available on this capacity drive.

**In order to access a Model 2230 disk cartridge in a Model 2260 or 2260B series Disk Drive, a special disk device address of 350 must be used. The special address causes this series to initiate a routine which simulates the Model 2230 track spacing and platter format for reading on the Removable Platter. The user is then able to read information from the cartridge in Model 2230 format with standard disk statements, while the cartridge is loaded in a Model 2260/2260B series drive. For example, the statement LIST DC R/350 generates a listing of the Catalog Index from a Model 2230 cartridge loaded in a Model 2260/2260B drive. Similarly, the special address can be assigned to a file number, and referenced indirectly in statements which do not permit the use of a device address. For example, the statements

```
SELECT #3 350
DATALOAD DC OPEN R #3, "TEST"
```

could be used to reopen the file TEST on a Model 2230 cartridge in a Model 2260/2260B Disk Drive.

If the Model 2260/2260B is the second, or subsequent, disk drive in a system, the special address must be calculated by adding a HEX(40) to the disk device address. For example, if the address of the Model 2260/2260B is 320, the special address is 360; if the normal address is 330, the special address is 370, etc. Note that the special address should not be used to access the Fixed Platter of the Model 2260/2260B, nor should it be used to access a Removable Platter formatted in the Model 2260/2260B itself.

3. ALIGNMENT PROCEDURES

The 2260B alignments/adjustments are described in Service Newsletter 76.2 (TRK \emptyset Head Alignment, Index Transducer Adjustment, Azimuth) and the Diablo 44B Maintenance Manual. Refer to either of these documents when alignments and/or adjustments are required. The 2260 alignments/adjustments are described in Service Bulletin 43.1 and the Diablo Series 40 Maintenance Manual.

4. STORAGE CAPACITY CONVERSION PROCEDURES

Storage capacity conversion from a 2260/2260B $\frac{1}{4}$ to a 2260/2260B $\frac{1}{2}$ or to a 2260/2260B is accomplished by changing the PROM loading on the 6298 PCB. These changes are designated in the PROM loading variation chart below. All other hardware in both the Wang processor and the Diablo section remains the same.

PROM LOADING VARIATION CHART

I.C.	2260 or 2260B	2260 $\frac{1}{2}$ or 2260B $\frac{1}{2}$	2260 $\frac{1}{4}$ or 2260B $\frac{1}{4}$
L3	378-0356	378-0356	378-0356
L7	378-0357	*378-0527	*378-0526
L4	378-0358	378-0358	378-0358
L8	378-0359	378-0359	378-0359
L1	378-0360	378-0360	378-0360
L5	378-0361	378-0361	378-0361

*Only PROMs that differ from 2260B loading.

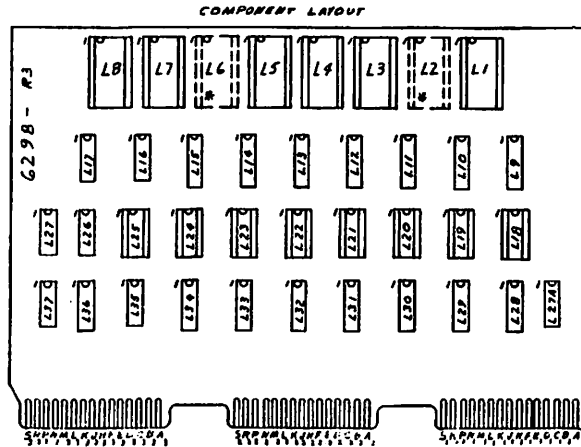

April 21, 1977

MASS STORAGE DEVICES #10 MODEL 2260B SERIES INTRODUCTION

1. INTRODUCTION

The Wang Model 2260B Fixed/Removable Disk Drive provides a high-capacity, direct-access storage medium for all Wang systems except the 2200A. (However, the System 2200S and WCS/10 require Option-24, the Disk ROM, in order to support a disk.) The Model 2260B provides ten megabytes (10,027,008 total bytes) of on-line storage capacity. The 2260B also is available in two smaller configurations, for applications requiring lesser data bases.

PHYSICAL CHARACTERISTICS

The Model 2260B Disk Drive unit holds a pair of disk platters, one fixed and one removable. The disk drive's total storage capacity is distributed equally between the two platters.

Each disk platter has two recording surfaces, which are divided into a number of concentric circular recording tracks. Every track is, in turn, subdivided into 24 "sectors". A sector is the smallest addressable unit on the disk, and can store 256 bytes of information (program text or data). The sectors on each platter are sequentially numbered, and individual sectors can be directly addressed.

The 2260B series is designated in this manner because the Diablo Model 44B disk drive is interfaced with the Wang processor, whereas the 2260 contains the Diablo Model 44 and the 2230 series contains the Model 43. See summary chart below.

WANG

LABORATORIES, INC

836 NORTH STREET, TEWKSBURY, MASSACHUSETTS 01876, TEL (617) 851 4111, TWX 710 343 6769, TELEX 94 7421

Printed in U.S.A.
13-26

DISK DRIVE SUMMARY

WANG MODEL #	CAPACITY (BYTES)	DIABLO MODEL #
2230-1	1,288,800	43
2230-2	2,457,600	43
2230-3	5,013,504	43
2260B 1/4	2,457,600	44B
2260B 1/2	5,013,504	44B
2260B	10,027,008	44B
2260	10,027,008	44

2. DISK PLATTER COMPATABILITY

The disk platter compatability chart below reflects the disk cartridge interchangeability between the various disk drives offered by Wang Labs. Notice that all 2260Bs are capable of reading all 2230 platters (using a special disk address explained after the chart) and that there is complete compatability between 2260 and 2260B platters.

DISK PLATTER COMPATABILITY CHART

A PLATTER CREATED ON A:	CAN BE READ BY A:						
	2230-1	2230-2	2230-3	2260	2260B	2260B1/2	2260B1/4
2230-1	✓	✓	✓	✓**	✓**	✓**	✓**
2230-2	✓*	✓	✓	✓**	✓**	✓**	✓**
2230-3	✓*	✓*	✓	✓**	✓**	✓**	✓** *
2260				✓	✓	✓*	✓*
2260B				✓	✓	✓*	✓*
2260B1/2				✓	✓	✓	✓*
2260B1/4				✓	✓	✓	✓

*The platter can be read up to the maximum address available on this capacity drive.

**In order to access a Model 2230 disk cartridge in a Model 2260B Disk Drive, a special disk device address of 350 must be used. The special address causes the Model 2260B to initiate a routine which simulates the Model 2230 track spacing and platter format for reading on the Removable Platter. The user is then able to read information from the cartridge in Model 2230 format with standard disk statements, while the cartridge is loaded in a Model 2260B drive. For example, the statement LIST DC R/350 generates a listing of the Catalog Index from a Model 2230 cartridge loaded in a Model 2260B drive. Similarly, the special address can be assigned to a file number, and referenced indirectly in statements which do not permit the use of a device address. For example, the statements

```
SELECT #3 350
DATALOAD DC OPEN R #3, "TEST"
```

could be used to reopen the file TEST on a Model 2230 cartridge in a Model 2260B Disk Drive.

If the Model 2260B is the second, or subsequent, disk drive in a system, the special address must be calculated by adding a HEX(40) to the disk device address. For example, if the address of the Model 2260B is 320, the special address is 360; if the normal address is 330, the special address is 370, etc. Note that the special address should not be used to access the Fixed Platter of the Model 2260B, nor should it be used to access a Removable Platter formatted in the Model 2260B itself.

3. ALIGNMENT PROCEDURES

The 2260B alignments/adjustments are described in Service Newsletter 76.2 (TRK Ø Head Alignment, Index Transducer Adjustment, Azimuth) and the Diablo 44B Maintenance Manual. Refer to either of these documents when alignments and/or adjustments are required.

4. CONVERSION PROCEDURES

Conversion from a 2260B 1/4 to a 2260B 1/2 or to a 2260B is accomplished by changing the PROM loading on the 6298 PCB. These changes

are designated in the PROM loading variation chart below. All other hardware in both the Wang processor and the Diablo section is identical.

PROM LOADING VARIATION CHART

I.C.	2260B	2260B 1/2	2260B 1/4
L3	378-0356	378-0356	378-0356
L7	378-0357	*378-0527	*378-0526
L4	378-0358	378-0358	378-0358
L8	378-0359	378-0359	378-0359
L1	378-0360	378-0360	378-0360
L5	378-0361	378-0361	378-0361

*Only PROMs that differ from 2260B loading.

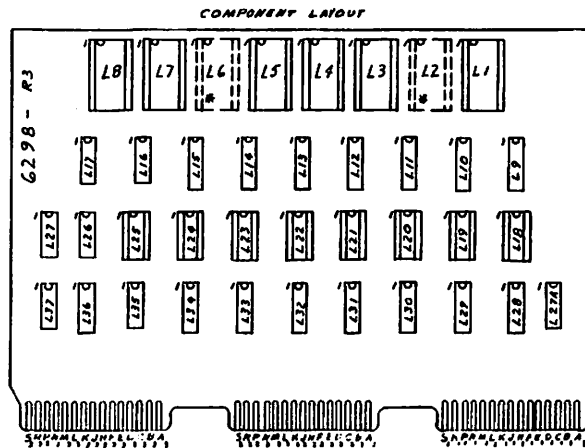

Service Newsletter

#53

GENERAL #14

This newsletter contains the following items:

- A. Signetics 8T25 (WL# 376-0130)
- B. WL# 300-1270 Alternate Purchased Part
- C. 6297 Boards - Fairchild 74195 (WL# 376-0097)

A. Signetics 8T25 (WL# 376-0130)

Signetics has mixed in a small quantity of 8T25's marked with 10066015. Please be advised that these parts are in fact 8T25's.

B. WL# 300-1270 Alternate Purchased Part

Erie Capacitor is going to supply us with 831000Y5D271J instead of a 831000Y5F271K.

The differences are, the substitute has a temperature coefficient of +3.3% and a 5% tolerance. Our standard part has a TC of +7.5% and a tolerance of +10%.

C. 6297 Boards - Fairchild 74195 (WL# 376-0097)

The Fairchild 74195 (WL# 376-0097) should not be loaded in location L2 and L14 on boards 6297-1, 6297-2, 6297-3. This restriction does not apply to Fairchild's 9300 device which works properly in this application.

WANG

LABORATORIES, INC

836 NORTH STREET, TEWKSBURY, MASSACHUSETTS 01876. TEL (617) 851 4111, TWX 710 343 6769, TELE X 94 7421

Printed in U.S.A.
1.3-266

HARD DISK

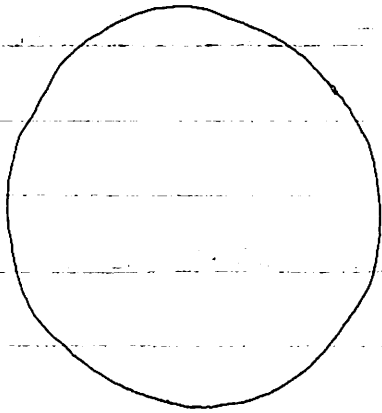

408 TRACKS - 0 - 407

24 SECTORS/TRACK

2230 - 100 TPI

2260 - 200 TPI

24 SECTOR NOTCHES PLUS INDEX NOTCH

SECTORS 0-23 LOWER HEAD, 24-47 UPPER HEAD, ETC.

2244

FILE READY - SPINDLE SPEED, HEADS OVER TRACKS, BRUSHES HOME

BSRW - (READY TO SEEK, READ, OR WRITE)

POSITION TRANSDUCER - TO FIND DIFFERENT TRACKS

GIVES ACTUAL 1. POSITION 2. DIRECTION 3. VELOCITY

VELOCITY - ^{SEEK} OVER 256 TRACKS - FULL SPEED

SEVERAL DIFFERENT SPEEDS

SECTOR 1 BYTE = 8 BITS = 1 ASCII CHARACTER

PREAMBLE I SYNC I HEADER PREAMBLE II SYNC 2 DATA LRC CRC POSTAMBLE

20 BYTES

2 BYTES

256 BYTES 1 BYTE 2 BYTES 20 BYTES

ALL ZEROS

TRACK &
SECTOR ADDR.

CPU GENERATES & CHECKS LRC (PARITY CHAR. GENERATED BY DATA FIELD)

~~DATA~~ MICROPROCESSOR GENERATES & CHECKS CRC (GENERATED ACCORDING TO DATA FIELD & LRC)

2260 - 38 msec. AVG. SEEK TIME

HIGHEST SECTORS - 2230-1, -2, -3 & 2260 2399, 4799, 9791, 19583

Error 72 - 2 BIT CRC CHECKS DATA + LRC w/ EXCLUSIVE
OR CIRCUITRY IN MICROPROCESSOR BOARD

Error 68 - 1 BIT LRC CHECKS DATA AT 6311 CARD IN
CPU

Error 67 - HEADS NOT ON TRACK

Error 60 - ARRAY TOO SMALL (SOFTWARE)

61 - DID. NOT RESPOND TO CPU IN CERTAIN TIME (MICROPROCESSOR)

62 - FILE FULL (SOFTWARE)

64 - SECTOR NOT ON DISK (SOFTWARE OR SHUGART HARDWARE)

65 - DISK NOT READY (HARDWARE)

71 - LOST TRACK OF ADDRESS, SEEK INCOMPLETE (DIABLO HARDWARE)

80 - CATALOGUE NOT IN FILE (SOFTWARE)

82 - NO END OF FILE (SOFTWARE)

CHECK LITE

① WRITING WHEN NOT SUPPOSE TO OR NOT WRITING WHEN
SUPPOSED TO

② POWER SUPPLY

ERROR LITE

① WRITE CHECK

② NO FILE READY

③ SEEK INCOMPLETE (ERROR 71)

④ LOGICAL ADDRESS INTERLOCK

2260B

DATA TRANSFER BOARD (12406)

SW	1	2	3	4
	ON	ON	ON	OFF

SW 1 - ALWAYS ON ERASE CURRENT

SW 2 - WRITES PROTECT REMOVABLE DISK

SW 3 - WRITES PROTECT FIXED DISK

SW 4 - ALWAYS OFF SEPARATES DATA + CLOCK PULSES

SW 2 + 3 - IF EITHER OFF

LOGIC BOARD (12066) - 3 STYLES (SHOULD CHECK ALIGNMENT IF CHANGED)

SW 1 - ON INDEX ONLY ON WHEN DOING ALIGNMENT

(IF ON WITH REGULAR DISK ERR 67 REMOVABLE DISK)

(IF OFF WITH ALIGNMENT CARTRIDGE)

SW 2 - ON 1500 RPM

SW 3 - NOT USED

SW 4 - ALWAYS ON (ON THE 12065-02 BOARD ARTWORK)

IF OFF INDEX PULSES FROM FIXED DISKS USED TO WRITE REMOVABLE DISK

ADDRESS LOGIC BOARD (12064 + 12101)

SW 1 - 100 TPI ALWAYS OFF

SW 2 - NEG ATTN ALWAYS OFF

SW 3 / SW 4	FILE 1, 2, 3, 4	3, 2, 1, 0	SW 4 SW 3
			LOW HI

SERVO BOARD (12068 - 12099) 68 SERVO MUST BE USED w/ 64 AL + 99 w/ 101

CAN BE RUN w/ WRONG STYLE TO TEST OUT (MIGHT RUN SLOW)

2270

6718/7018

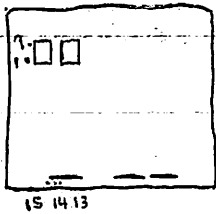

ETCH SIDE

PIN 1 (TOP LEFT PROM) +12

PIN 9 " " -12

PIN 15 - +5

PIN 14 - +24

PIN 13 - -5

2230 + 2260A

+24 POWER - SPINDLE

CHECK IN PS, RW BOARD, &

+24 CIRCUIT - EVERYTHING ELSE

HS BOARD

WITH -24

+5V PIN 6 ACROSS CARD CAGE OR ON R/W BOARD ADJ. IN PS B62

+15 & -15V PIN 10 OF SL, SR, OR, ETC. -15

PIN 13 OF SD, OR, TC, & SL +15

+5V - EMITTER OF J28 R/W BOARD

-5V - EMITTER OF J22 R/W BOARD

FUSE IN BACK OF PS 7A - NO POWER AT ALL

ALIGNMENT

1V/cm 1mm/sec/cm

ADJ. ALLEN

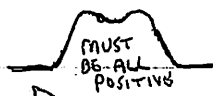

MIN PK 70-80% OF MAX PK

1. TRACK 0 A. SAMS ENVIRON - 15 MIN WARM, DIFFERENT - 30 MIN WARM, REMOVES & REBORN FOR 15 min. B. RESTORE SW. ON C. CH. 1 TO TP 13 ON SO

2. RADIAL ALIGNMENT A. SET TO TRACK 146 OR 73 1MM PKs ALL EVEN

CH 1 TO TP 1 OF EXERCISER, SYNC. PIN 11 SR BOARD C. CHECK OTHER HEAD

3. INDEX A. SET TO TRACK 10 OR 5 B. CH 1 TO TP 1, SYNC. SP PIN 11, NEG. 1MM

C. CHECK AT 402 & 201 FOR AZIMUTH D. CENTER BETWEEN UP & LOW HEAD

REV	DATE	BY	CHK
1			



LIGHT-TERMINAL DESIGNATIONS, VIEW FROM BOTTOM OF CONNECTOR

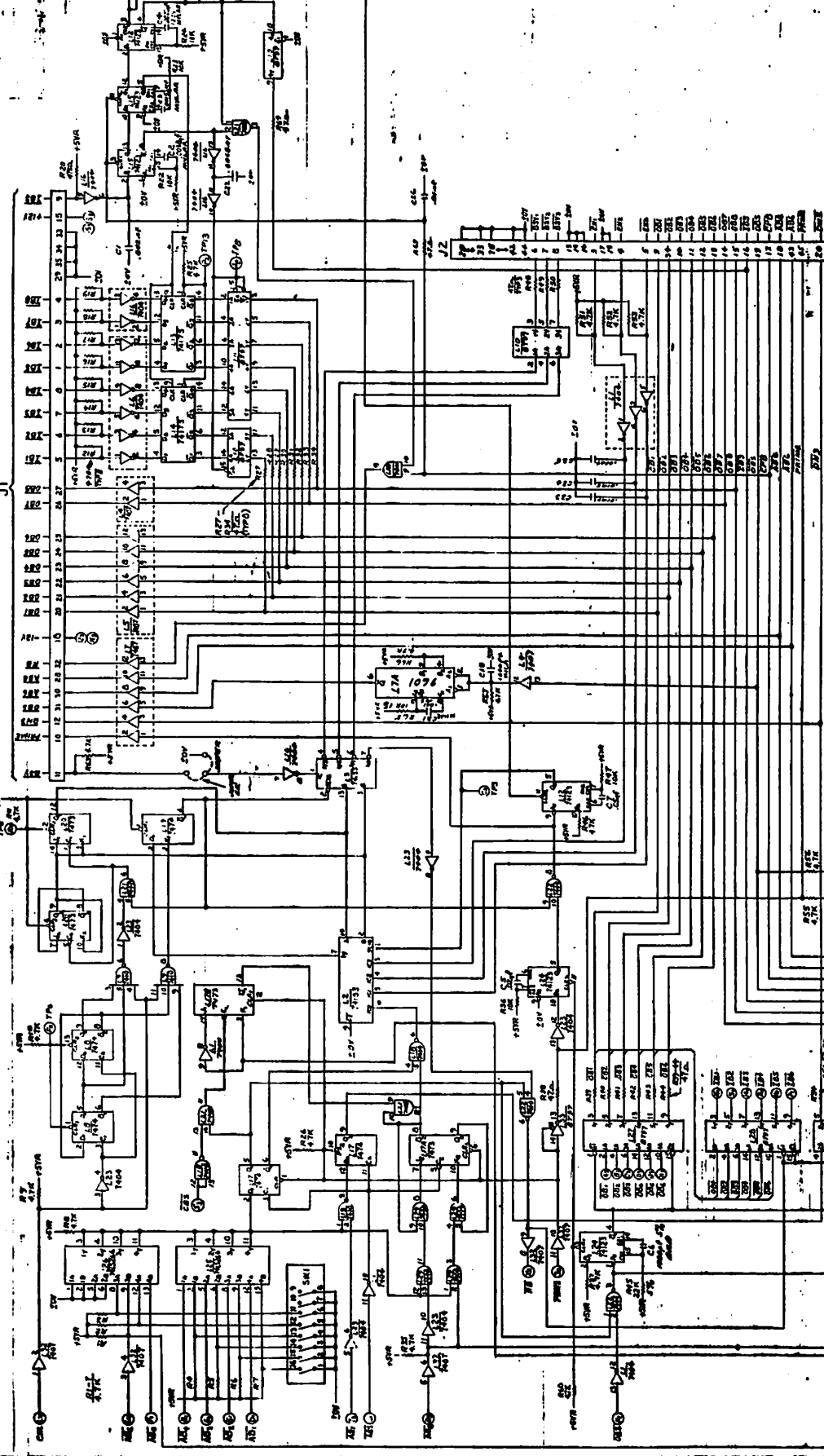

LOC	REF	QTY	DESCRIPTION
1	1A1	1	...
2	1A2	1	...
3	1A3	1	...
4	1A4	1	...
5	1A5	1	...
6	1A6	1	...
7	1A7	1	...
8	1A8	1	...
9	1A9	1	...
10	1A10	1	...
11	1A11	1	...
12	1A12	1	...
13	1A13	1	...
14	1A14	1	...
15	1A15	1	...
16	1A16	1	...
17	1A17	1	...
18	1A18	1	...
19	1A19	1	...
20	1A20	1	...
21	1B1	1	...
22	1B2	1	...
23	1B3	1	...
24	1B4	1	...
25	1B5	1	...
26	1B6	1	...
27	1B7	1	...
28	1B8	1	...
29	1B9	1	...
30	1B10	1	...
31	1B11	1	...
32	1B12	1	...
33	1B13	1	...
34	1B14	1	...
35	1B15	1	...
36	1B16	1	...
37	1B17	1	...
38	1B18	1	...
39	1B19	1	...
40	1B20	1	...

COMPONENT	W.L. PART NO.
1A1	330-3047
1A2	330-3047
1A3	330-3047
1A4	330-3047
1A5	330-3047
1A6	330-3047
1A7	330-3047
1A8	330-3047
1A9	330-3047
1A10	330-3047
1A11	330-3047
1A12	330-3047
1A13	330-3047
1A14	330-3047
1A15	330-3047
1A16	330-3047
1A17	330-3047
1A18	330-3047
1A19	330-3047
1A20	330-3047
1B1	330-3047
1B2	330-3047
1B3	330-3047
1B4	330-3047
1B5	330-3047
1B6	330-3047
1B7	330-3047
1B8	330-3047
1B9	330-3047
1B10	330-3047
1B11	330-3047
1B12	330-3047
1B13	330-3047
1B14	330-3047
1B15	330-3047
1B16	330-3047
1B17	330-3047
1B18	330-3047
1B19	330-3047
1B20	330-3047

LOC	REF	QTY	DESCRIPTION
1	1A1	1	...
2	1A2	1	...
3	1A3	1	...
4	1A4	1	...
5	1A5	1	...
6	1A6	1	...
7	1A7	1	...
8	1A8	1	...
9	1A9	1	...
10	1A10	1	...
11	1A11	1	...
12	1A12	1	...
13	1A13	1	...
14	1A14	1	...
15	1A15	1	...
16	1A16	1	...
17	1A17	1	...
18	1A18	1	...
19	1A19	1	...
20	1A20	1	...
21	1B1	1	...
22	1B2	1	...
23	1B3	1	...
24	1B4	1	...
25	1B5	1	...
26	1B6	1	...
27	1B7	1	...
28	1B8	1	...
29	1B9	1	...
30	1B10	1	...
31	1B11	1	...
32	1B12	1	...
33	1B13	1	...
34	1B14	1	...
35	1B15	1	...
36	1B16	1	...
37	1B17	1	...
38	1B18	1	...
39	1B19	1	...
40	1B20	1	...

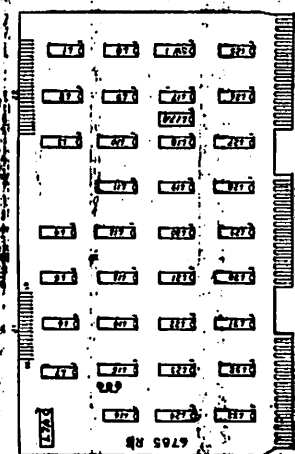

REV	DATE	BY	CHK
1			

REV	DATE	BY	CHK
1			

REV	DATE	BY	CHK
1			

REV	DATE	BY	CHK
1			

WANG

5873

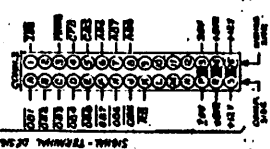
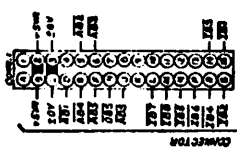

WIRE	TO	FROM
1	24V	24V
2	0V	0V
3	0V	0V
4	0V	0V
5	0V	0V
6	0V	0V
7	0V	0V
8	0V	0V
9	0V	0V
10	0V	0V
11	0V	0V
12	0V	0V
13	0V	0V
14	0V	0V
15	0V	0V
16	0V	0V
17	0V	0V
18	0V	0V
19	0V	0V
20	0V	0V
21	0V	0V
22	0V	0V
23	0V	0V
24	0V	0V

LOCATION	REL. PART NO.	QTY.	REVISION
11	315-0051	1	1
12	316-2056	7	4
13	316-0053	11	4
14	316-0081	7	14
15	316-2052	7	14
16	316-2057	7	14
17	316-2058	7	14
18	316-2059	7	14
19	316-2060	7	14
20	316-2061	7	14
21	316-2062	7	14
22	316-2063	7	14
23	316-2064	7	14
24	316-2065	7	14

COMPONENT	REL. PART NO.
SW 1	315-1503
J2	315-2097
J1	315-2098
R-23A739	315-3047
R-23A740	315-3047
R-23A741	315-3047
C1	300-2006
C2-5	300-1903
C6,7	300-4023
C8	300-4023
D1-4	300-0000
D5,6	300-1001
SW 1/2	300-0047

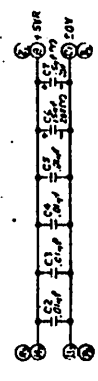
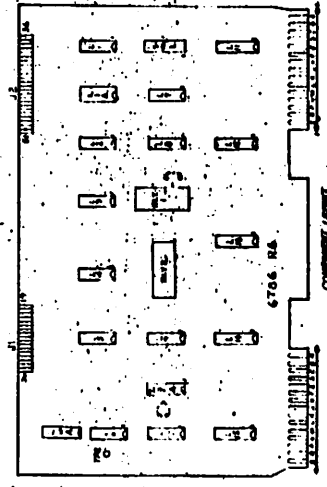

NOTE: See 6706-1000000000 for details on wiring.

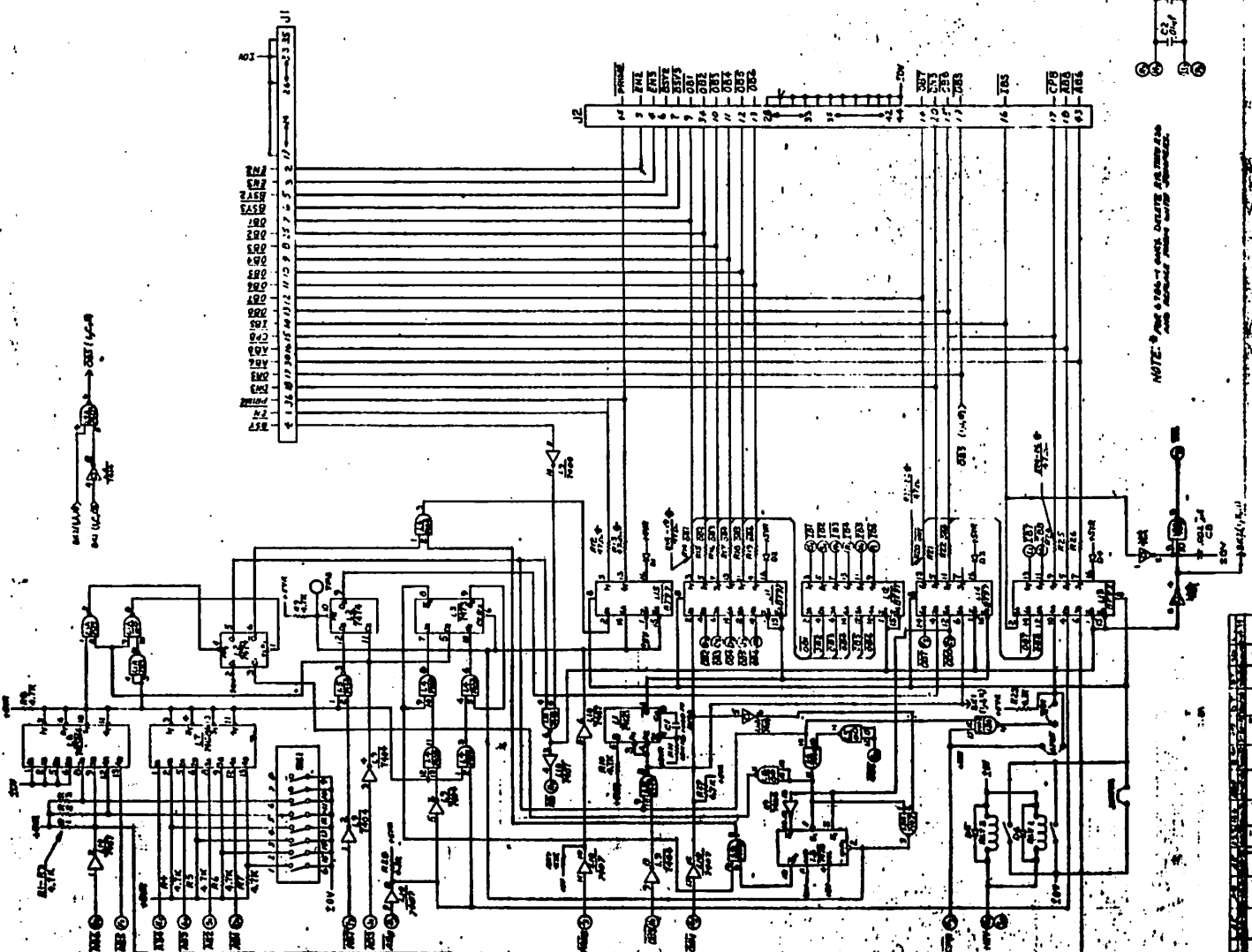

WANG
 MODEL 720
 SERIAL NO. 1000000000
 DATE 10/10/60
 E 6706 II

AUTOMATIC FILE CATALOGING

Starting with a disk with no useful information on it, execute the following statement:

```
SCRATCH DISK F LS = 24, END = 1023
```

With the exception of the first 6 bytes of sector #0 this statement writes HEX(00) at every byte of every sector starting with sector #0, and ending at the sector which is 1 less than the total # of index sectors specified by the LS parameter. (In this case #23). This statement also reads the sector specified by the END parameter. (sector #1023).

The following program will print any sector in hexadecimal. The sector address can be a variable or a constant.

```
10 DIM A$(16)
20 DATALOAD BAF(0,L) A$( )
30 HEXPRINT A$( )
```

FOR MULTIPLE SECTORS CHANGE
O TO X WITH A FOR/NEXT LOOP

The first 6 bytes of sector #0 would appear as follows:

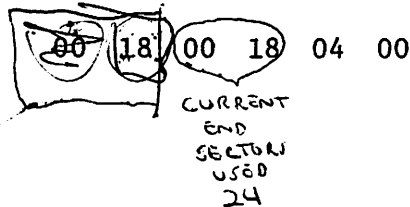

IF WRITTEN ON R DRIVE WOULD BE
80 18 | 80 18 | 84 00 | 80 00 | 80 00
SEE 1ST PARAGRAPH NEXT PAGE

Every time a new program or datafile is added the current end (bytes 3+4) is incremented by the # of sectors used by the new file.

The 'END OF CATALOG' can be altered by the basic verb MOVE END as in MOVE END F = 1000. This statement sets the End of Catalog back to 1000. Error #64 will result if the end specified is larger than the maximum legal sector address and error #74 if the end specified is less than the current end.

In the following program 1 + 2 byte hexadecimal numbers are covered by statements #30 and #50.

```
1 BYTE - #30
2 BYTE - #50
```

The following program simulates the first phase of a LIST DCF statement.

```
10 DIM A$(16) 16
20 DATALOAD BAF(0,L) A$( )
30 A = VAL(STR(A$(1),2,1)) CHANGE TO DECIMAL 2ND BYTE OF A#1 (18 = 24)
40 PRINT "INDEX SECTORS" =";A
* 50 B = VAL(STR(A$(1),5,1))*256 + VAL(STR(A$(1),6,1)) B = 1024
60 PRINT "END OF CATALOG" =";B
70 C = VAL(STR(A$(1),3,1))*256 + VAL(STR(A$(1),4,1)) 0*256+24 = 24
80 PRINT "CURRENT END";C
```

USING

* 50 CHANGE TO DECIMAL 5TH BYTE OF A#1 (04=4) MULTIPLY BY 256 (256*4 = 1024) AND ADD THE DECIMAL VALUE OF THE 6TH BYTE OF A#1 (00=0) 0 + 1024 = 1024

If this program were run on a platter which was created on a removeable type disk then it would be necessary to mask out a high-order 8 bit from the first byte of any 2 byte hexadecimal #'s. This 8 bit being on is something that was micro-coded but never used. To turn it off without effecting other values add statement #25. (bytes 3 +5).

3RD BYTE = 0000 0000
 0111 1111
 5TH BYTE 0000 0000
 0000 0100
 0111 1111
 0000 0100

5TH BYTE
 AND 3RD BYTE OF A\$(1) WITH 7F
 25 AND(STR(A\$(1),3,1),7F):AND(STR(A\$(1),5,1),7F)

The following statement opens a datafile on the fixed disk by the name "DATAFILE"

10 DATASAVE DC OPEN F 100, "DATAFILE"

SECTOR TO BE USED

This file would be indexed in sector #18. While the sector chosen is not sequential, the sectors themselves are filled sequentially. Therefore, information pertaining to this file would be stored in the first 16 bytes, the next file in sector #18 would occupy bytes 17-32 etc. If #18 were full, #17 would be checked to see if it were full. It would continue decrementing until it found an open space or reached sector 0. If it reached #0 and has not found an open space it would go to the largest index sector, and work its way back to the original. If no sectors were found to have an empty slot error #88 (CATALOG FULL) would result.

The datafile "DATAFILE" would appear as follows:

10 80 00 7C 00 7E 00 00 4441614146495245

1. Indicates if the file is scratched or active.
 HEX(10) = Active HEX(11) = Scratched
2. Indicates type - program or Datafile.
 HEX(80) = Program HEX(00) = Data
3. Bytes 3 + 4 are a 2 byte hexadecimal # containing the starting sector address.
4. Bytes 5 + 6 are a 2 byte hexadecimal # containing the ending sector address.
5. Byte 9-16 contain the program name.

If this were on a removeable disk the high order 8 bit would have to be masked out of bytes 3 + 5.

The # of sectors used by a file is stored in bytes 2 + 3 of the ending sector as a 2 byte hexadecimal #. In this case it would be in sector #123.

$$X = \text{INT}(19584 * \text{RND}(1))$$

X = WHOLE NUMBER DERIVED FROM MULTIPLYING 19584 X

A RANDOM > 0 AND < 1

ON ERROR E\$,N\$ GOTO 110 (E\$ - ERROR #, N\$ - STATEMENT #)

WANG

ECN

CE # 142

ECN No. 10182

SHEET 1 OF 5
DATE 2-5-79
RFA NO. (REF)

ORIGINATOR Paul Congo DEPT. 16 EXT. 2663 DATE 11/28/78
MODEL NO. 2260B TITLE

ECN NO. 10182

PART NO. See Below	PART NAME Ram Prom memory	REV. F	T	PC.REV. FROM	TO	ELEC.REV. FROM	TO
DWG. NO. 6298	(DWG. TITLE) 56						
ASSY. PART NO.	ASSY. TITLE					EFFECTED <input type="checkbox"/>	NO EFFECT <input type="checkbox"/>

DESCRIPTION OF CHANGE

Change schematic by updating software loading chart for 210-6298-1F, 1H and 1J as follows:

VARIATION MODEL	-1F-	-1H-	-1J-
	2260	22601/4	2260 1/2
L3	378-0546R1	378-0546R1	378-0546R1
L7	378-0547R1	378-0547R1	378-0547R1
L4	378-0548R1	378-0548R1	378-0548R1
L8	378-0549R1	378-0549R1	378-0549R1
L1	378-0550R1	378-0550R1	378-0550R1
L5	378-0551R1	378-0567R1	378-0568R1

Change BOM's 210-6298-1F, 210-6298-1H and 210-6298-1J to reflect these changes.

NOTE: To convert a 2260 (using the new R1 PROMs) to either 1/2 or 1/4 storage, Chip #6 (Location L5) is changed instead of Chip #2 (Location L7) as was the case with the old PROMs

REASON FOR CHANGE

To make MVP compatible
Eliminates "HANG UP" WHEN LOADING OPERATING SYSTEM ON VP + MVP

2075J/37

43

NEW PURCHASE REQ'D. SHOP REWORK REQ'D. VENDOR REWORK REQ'D.

CUSTOMER ENGINEERING <input type="checkbox"/> IMMEDIATE CUST. <input checked="" type="checkbox"/> CUST. PER NEXT CALL <input type="checkbox"/> INFORMATION ONLY <input type="checkbox"/> NONE	ACKNOWLEDGE BY: _____ DATE: _____	<input checked="" type="checkbox"/> MANDATORY CHANGE <input checked="" type="checkbox"/> DOCUMENTATION CHANGE (PL, BOM, DWG) <input type="checkbox"/> EASE OF MFG., COST REDUCTION <input type="checkbox"/> PRODUCT IMPROVEMENT
---	---	--

DISPOSITION	Bonded	FINAL ASSY AREA	SUB ASSY AREA	PARTS		Future MFG
				IN House	Outside Vendor	
USE AS IS TO PREVIOUS REV.	X					
TO CONFORM		X				X
TO CONFORM IF NOT BEYOND OPERATIONS EFFECTED						

FINAL APPROVAL *[Signature]*
 APPROVED DESIGN ENGRG. *[Signature]*
 APPROVED MFG. ENGRG. *[Signature]*
 WRITTEN BY Paul Richer *[Signature]* RP

WANG

LABORATORIES, INC.

BA #40

MEMORANDUM

TO: ALL EASTERN AREA CUSTOMER ENGINEERS

FROM: SCOTT TAGEN

SUBJECT: DIABLO DISK DRIVES

DATE: MARCH 24, 1977

When using a 7013 Exerciser board to align a 44B, the input must be terminated. Since 44B terminators are built into the I/O cable, we will be distributing one of the Model 40 terminators (part number 11441) to each office. Order more if you have a need for them. Any office that needs a tri-bit alignment cartridge, and/or a 7013 Exerciser board should order them. The part number for the alignment cartridge is 726-0382. Service Bulletin number 43.1 explains Exerciser operation.

Due to the large number of boards received in the Area shop with no apparent failures, (approximately 30%), it seems that some confusion exists as to 43-44 compatibility. Listed below are applicable I.S.N.'s which should be carried by all Customer Engineers when servicing disks.

I.S.N. #31 lists compatibility between 2230/2260 boards. Also OR board #11875 can be used in place of the 11414. Resistor E46 is loaded for a 2260, and cut out for a 2230.

I.S.N. #45, set up a system of labeling 2230 boards with a '3' and 2260 boards with a '4'. However, if the label is missing, or someone else made a modification, the board may seem to be bad. Before returning the board for repair, use I.S.N. #31 to determine if the board is the correct one to use in the drive you are repairing. Also, if you need a board which you don't have, it is usually possible to change it to the one you need. If you do this, be sure and switch the labels so that the next Customer Engineer doesn't get confused.

I.S.N. #116 and 116A lists SR board interchangeability and OR/SL board compatibility.

I.S.N. #125 further explains I.S.N. 116.

In some instances, if a wrong board is used in a machine, the drive will not function. But in some cases, intermittent errors will occur. Checking these I.S.N.'s every time you repair a disk will prevent needless recalls. If you have any further questions, do not hesitate to call me.

Regards,

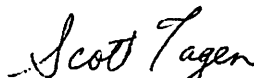

SCOTT TAGEN
EASTERN AREA TECHNICAL SPECIALIST

ST/mf

EDITED BY CUSTOMER ENGINEERING DIVISION

DIABLO DISK EXERCISER AND TRIBIT ALIGNMENT CARTRIDGES

INTRODUCTION

The purpose of this Service Bulletin is to familiarize the serviceperson with two items for alignment and testing of Diablo Disk Drives. Section 1 of this bulletin describes the Diablo Disk Exerciser, WLI #190-0703, and Section 2 describes the use of the Tribit Alignment Cartridge, WLI #726-0382.

1. DIABLO DISK EXERCISER

The Diablo Disk Exerciser, the 7013 board, is a testing device that allows the user to operate the Diablo Disk Drives used in the -30 and -60 independent of the 2200 (or 600/700) CPU. The 7013 can be used for disk drive testing and is useful for performing disk drive alignment.

1.1 DESCRIPTION

Looking at the 7013 tester, you will see two banks of switches, four indicators, two cables and two test points. Their labels and functions are:

- (a) TA - Track Address. When ON, the disk receives the track address from the track address switches. When OFF, the track address is generated randomly or sequentially by circuitry on the 7013 as selected by RND.

NOTICE:

This document is the property of Wang Laboratories, Inc. Information contained herein is considered company proprietary information and its use is restricted solely to the purpose of assisting you in servicing Wang products. Reproduction of all or any part of this document is prohibited without the consent of Wang Laboratories.

WANG

LABORATORIES, INC.

836 NORTH STREET, TEWKSBURY, MASSACHUSETTS 01876, TEL. (617) 851-4111, TWX 710 343-8769, TELEX 94-7421

Printed in U.S.A.
13-210A

- (b) DISP - Disable. When ON, the track address is disabled. The head will remain positioned wherever it is when the DISP switch is turned ON.
- (c) RST - Restore. When ON, the head is positioned at TRACK 0 for alignment. RST overrides the TA and RND switches.
- (d) HUP - Head Upper/Lower. ON selects the upper head, OFF selects the lower head.
- (e) DUP - Disk Upper/Lower. ON selects the upper (removable) disk, OFF selects the lower (fixed) disk.
- (f) RND - Random Track Generator. When ON, a random track address is generated. When OFF, a sequential track address is generated. In both cases, the TA switch must be OFF.
- (g) TK1 through TK256. These are the track address switches. Setting a track address switch ON causes the head to move to the appropriate track, but only when the TA switch is ON.
- (h) LAI - Logical Address Interlock. If ON, an illegal address has been selected.
- (i) SI - Seek Incomplete. If ON, indicates the head did not move to the track address requested.
- (j) FR - File Ready. When ON, indicates the drive is ready for use.
- (k) RSRW - Ready to Seek, Read or Write. When ON, indicates the drive is ready to do another read or write operation.
- (l) CABLE 1 - Plugs into the upper or lower head cable of the top disk.
- (m) CABLE 2 - Connects to the Diablo Read/Write Amplifier board to provide -5 volts for the amplifier on the 7013.

(n) TP1 - The output of the amplifier of the 7013.

(o) TP2 - +0 volts.

1.2 OPERATION

Remove the I/O cable from the rear of the Diablo Drive and install the 7013 Exerciser. Do not remove the terminator block. Set the switches for the desired type of operation and apply power to the disk drive.

With all switches in the OFF position (both banks), the track address will be incremented sequentially, and hence, move the head at 10 millisecond intervals. Setting the TA switch to ON will select a ~~X~~ track address as set by the Track Address switches. An illegal track address will turn the LAI indicator on.

Setting the RND switch to ON generates random track addresses and causes the head to move accordingly.

2. THE TRIBIT ALIGNMENT CARTRIDGE

2.1 DESCRIPTION

The alignment cartridge has a TRI BIT head alignment track and an Index Transducer alignment track recorded on each disk surface for adjusting hard disk drives from 100 to 500 TPI.

2.2 USING THE ALIGNMENT CARTRIDGE WITH THE 7013 EXERCISER

A user's manual is enclosed with each TRIBIT alignment cartridge, however, a standard alignment procedure is described in this Service Bulletin. A modified and corrected copy of the Tribit Manual is included at the end of this Service Bulletin for convenience. To align the disk drive with the disk exerciser, perform the following:

(a) Install the Disk Exerciser on the disk drive. Set the RST switch ON and all others OFF. Apply power to the drive.

- (b) Insert the alignment cartridge in the drive and allow 45 minutes for the system to stabilize.
- (c) Check the Track 0 alignment as described in the Diablo Disk Drive Maintenance Manual, Section 6.6.4.5. The Track 0 adjustment should never need to be performed unless the head positioner was changed. An out of alignment indication could indicate a bad PC board or a faulty Track 0 LED or phototransistor in the drive.
- (d) Head Alignment. Set the exerciser switches as follows:

630/730/2230	2260
TRK 64....ON	TRK 128....ON
TRK 8.....ON	TRK 16.....ON
TRK 1.....ON	TRK 2.....ON
TA.....ON	TA.....ON
All Others.....OFF	All Others.....OFF

Connect cable 2 of the 7013 Exerciser to the emitter of transistor J22 on the Read/Write Amplifier Board (RW-CB). Refer to Figure 1.

Remove the removable upper disk head cable from the bottom of the Read/Write Board to align the upper head, or the removable lower disk head cable to align the lower head. Connect the head cable to cable 1 of the 7013.

Connect channel 1 of the oscilloscope to TP1 on the 7013. When aligning the lower head on a -30, set the scope to INVERT. Trigger the oscilloscope on Ch. 1, SLOPE & LEVEL NEGATIVE.

A pattern similar to Figure 3 or 4 in the GDC Manual should be seen. Set a ground reference line on the oscilloscope and adjust the Vertical Sensitivity and Variable controls for a vertical deflection of six divisions from the ground reference to the highest peak. If the difference of the two peaks is more than $\frac{1}{2}$ of a division, adjust the head as described in the Diablo Disk Drive Maintenance Manual, Section 6.6.4.3.

While adjusting the head, readjust the oscilloscope variable control to maintain a deflection of 6 divisions. It is imperative that a 6 division deflection be maintained to measure the head deviation properly. The head is aligned when the two peaks are of equal amplitude.

CONNECT CABLE 2 TO THIS POINT

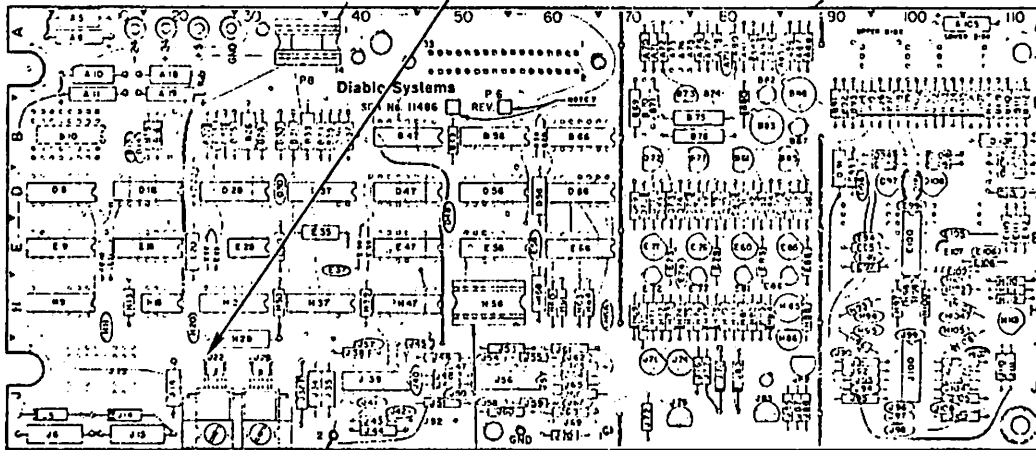

FIGURE 1 READ/WRITE AMPLIFIER BOARD

(e) Index Transducer Alignment. Set the exerciser switches as follows:

630/730/2230	2260
TRK 4....ON	TRK 8....ON
TRK 1....ON	TRK 2....ON
TA.....ON	TA.....ON
All Others....OFF	All Others....OFF

Connect cable 2 of the 7013 Exerciser to the emitter of transistor J22 on the Read/Write Amplifier board (RW-CB). Refer to Figure 1.

Remove head cable 1 from the bottom of the Read/Write board and connect it to cable 1 of the 7013.

Connect channel 1 of the oscilloscope to TP1 on the 7013 Exerciser. Connect the EXT. TRIGGER of the scope to Pin 11 of the SR board. Perform the index transducer alignment as described in the Diablo Disk Drive Maintenance Manual, Section 6.6.4.4.

APPENDIX A
GDC ALIGNMENT CARTRIDGE MANUAL

I. SPECIFICATIONS

GDC Alignment Cartridges are single disk cartridges inspected to meet stringent GDC purchase specifications.

A Head Alignment Track with TRIBIT pattern (Fig. 1) is prerecorded on each disk surface with allowable radial tolerance of ± 65 microinches when compared with GDC master alignment cartridge.

For Index Transducer Alignment each disk surface is prerecorded with a single flux transition marker located 180° from the index slot. At 1500 RPM the marker pulse (Pulse A, Fig. 2) is prerecorded 30.0 ± 3.0 μ sec. after the leading edge of the index pulse. For easy identification, it is followed after 10 μ sec. by 3.4 msec long burst of pulses.

II. ALIGNMENT PROCEDURE

The GDC Alignment Cartridge shall be used for R/W head and index transducer alignment as described.

1. Cleanliness

In addition to the cleanliness precautions stated in the disk drive maintenance manual, it is important that the mating surfaces of the alignment cartridge and the disk drive be free of contaminants during the alignment procedure.

CAUTION:

Do not use a material for cleaning that may tear or leave lint.

The cartridge armature plate and locating cone can best be cleaned using the ball of the index and little fingers.

CAUTION:

An alignment Cartridge which shows visible evidence of damage to the armature plate or locating cone (including flaking plating) will cause erroneous alignment.

2. Temperature Stabilization

Only after the disk drive has been temperature stabilized can the alignment cartridge stabilization be accomplished. The time required for temperature stabilization of the alignment cartridge is dependent upon the cartridge storage environment.

(1) Storage in the Drive Operating Environment

If the cartridge storage temperature is essentially the same as the recommended machine operating environment, the cartridge shall be allowed to run in the drive with heads loaded for 15 minutes prior to attempting the alignment procedure.

(2) Storage in Other Than the Drive Operating Environment

If the cartridge storage temperature is essentially different from the recommended drive operating environment, the cartridge shall be allowed to run on the drive with heads loaded for 30 minutes. The cartridge shall be removed and reinstalled. Alignment shall proceed after an additional 15 minutes of head loaded drive operation.

3. Hysteresis

In order to eliminate head positioner hysteresis (on disk drives where applicable) always approach the head alignment tracks from home or restore position.

4. R/W Head Alignment

Make certain that temperature stabilization was achieved at the R/W head alignment cylinder specified in Table 1. Set the oscilloscope for internal triggering with the time base setting of 2 or 5 μ s/cm. Connect scope to the "Read" test point on the drive. NOTE: Should the read back signal be different than in Fig. 1, it might be due to differential signal at the test point. To eliminate this problem it may be necessary to use a test point electrically closer to the head output. Simplification of head alignment procedure and complete overwrite protection is achieved by using the GDC Battery Powered Preamp into which the R/W head is plugged and which connects directly to the scope.

For head alignment align peaks B and C to touch a common horizontal line. If vertical gain is used as in Fig. 3, head alignment within 10 microinches can be achieved.

Head off-track position is determined by adjusting the highest peaks B or C to be 6 cm from ground, see Fig. 4. The difference between peak B and C expressed in centimeters is compared with Figure 4.

Head off-track position:

200 TPI	1 cm = 250 microinches
370 - 400 TPI	1 cm = 125 microinches

Other track spacing - contact GDC. NOTE: GDC tri bit cartridges can be used for any future track spacing without modification.

5. Index Transducer Alignment

Select index to burst cylinder for adjusting index transducer. Set oscilloscope time base to 10 μ s/cm while triggering externally from drive index.

Adjust the index transducer, or the index pulse delay as required until the peak of the single pulse is located at 30 \pm 5 microseconds at 1,500 RPM or 19 \pm 3 microseconds at 2,400 RPM from the leading edge of the index pulse.

Select the bottom head. The peak of the single pulse must be within 30 \pm 5 microseconds or 19 \pm 3 microseconds at 2,400 RPM. If not, readjust the index transducer until both heads are within specified limits. (See Figure 2.)

III. WARRANTY

GDC Alignment Cartridges are warranted against defective materials and workmanship for one (1) year from the date of shipment.

TABLE I

ALIGNMENT CARTRIDGE MODEL	DISK DRIVES USED IN	LOCATIONS OF ALIGNMENT CYLINDERS		NUMBER OF SLOTS IN HUB
		Head	Index Trans- ducer	
GDC 2315T	100 or 200 TPI	105 or 210	100 or 200	Index slot and eight (8) sector slots.
	1100, 2200 BPI			
	1500, 2400 RPM			
GDC 5440T	100 or 200 TPI	073 or 146	005 or 010	Index slot only.
	1100, 2200 BPI			
	1500, 2400 RPM			

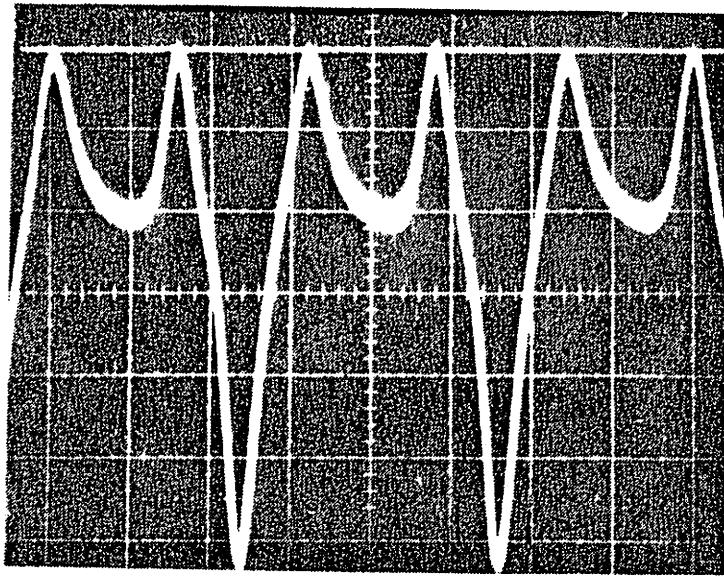

Head is aligned when pulses touch a common horizontal line

FIGURE 1
(Tribit pattern.)

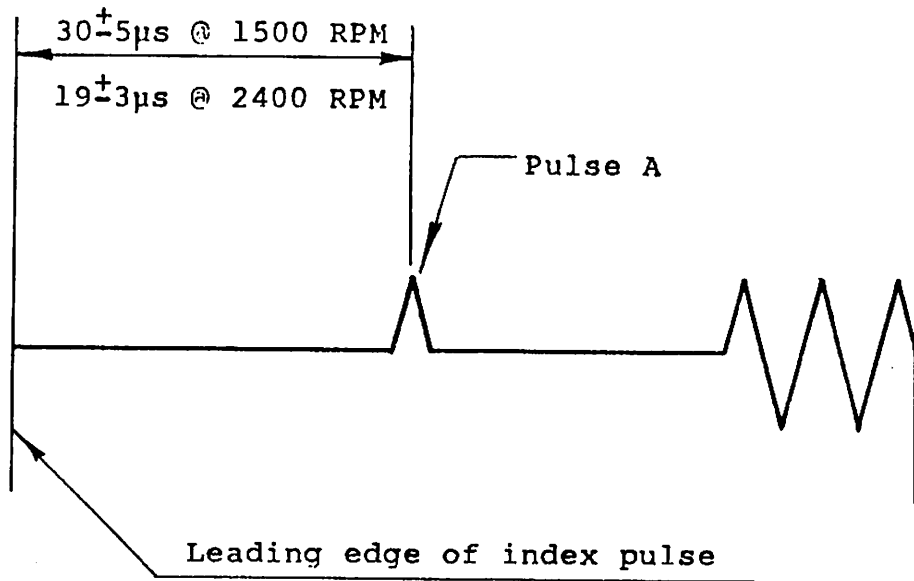

FIGURE 2
(Index transducer alignment.)

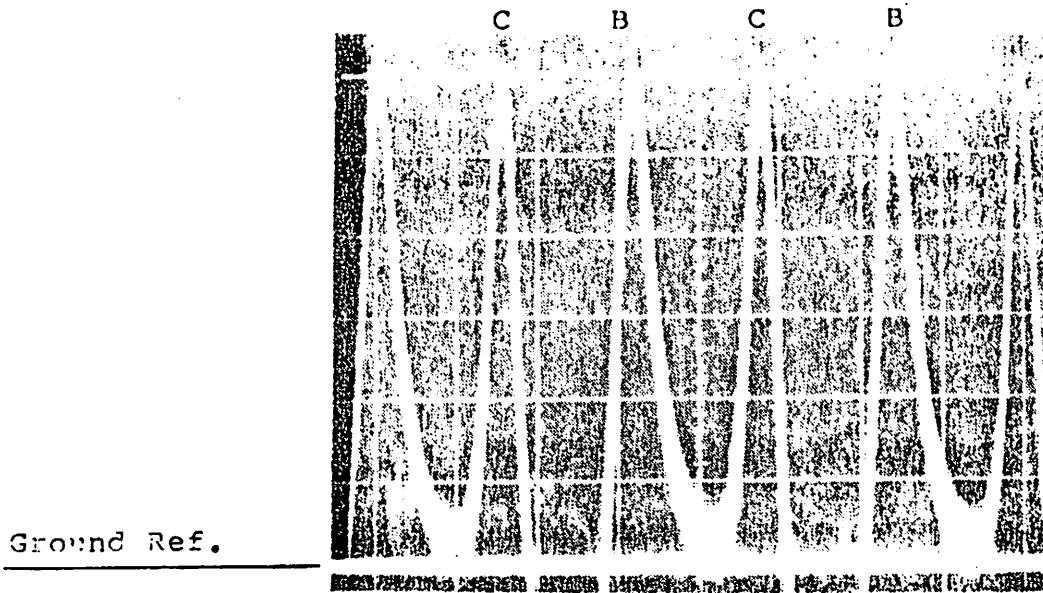

FIGURE 3
(Heads aligned)

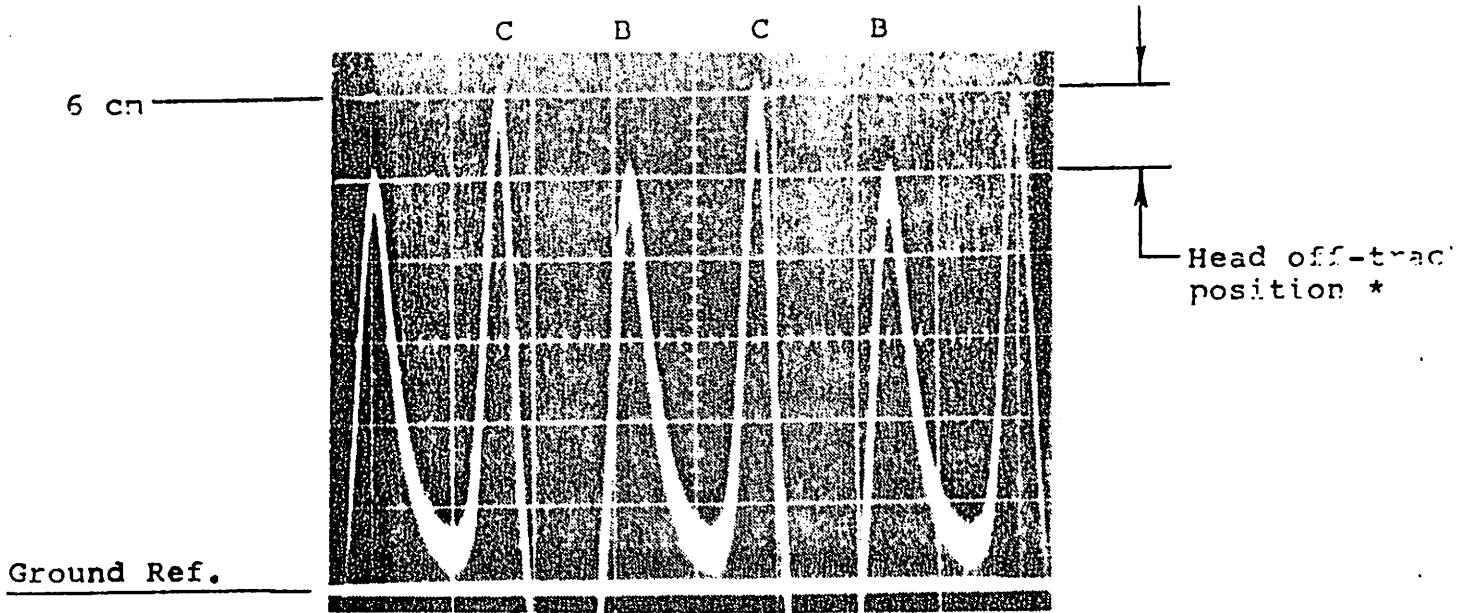

FIGURE 4
(Measuring head
off-track distance)

* Note: Head off-track position (when Ground to the highest peaks B or C equals 6 cm.)

200 TPI 1 cm = 250 microinches
370 - 400 TPI 1 cm = 125 microinches

OPERATION OF 7213 DISK EXERCISER

December 29, 1977

The 7213 Hard Disk Exerciser board is a testing device that allows the user to operate the Diablo Models 43, 44A, 44B and the CDC Hawk disk drives independently of a CPU. The 7213 is useful in performing disk drive alignments and general disk drive testing.

SWITCHES AND INDICATORS

The 7213 tester has two rows of switches, 6 cables, and 5 test points. Their labels and functions are as follows:

1. TK1 through TK256 (switch #'s 2 through 10 in Figure 1) - These are the track address switches. A track address is selected by setting the appropriate track address switches to ON. When the SEEK button is then pressed, the heads will move to the selected track. If the LOAD button is pressed, the selected track address will be loaded into the multiplexer of the exerciser board.
2. DS - DISK UPPER/LOWER (switch #11 in Figure 1) - When ON, the upper (removable) disk is selected; when OFF, the lower (fixed) disk is selected.
3. HS - HEAD UPPER/LOWER (switch #12 in Figure 1) - When ON, the upper head is selected; when OFF, the lower head is selected.

NOTICE:

This document is the property of Wang Laboratories, Inc. Information contained herein is considered company proprietary information and its use is restricted solely to the purpose of assisting you in servicing Wang products. Reproduction of all or any part of this document is prohibited without the consent of Wang Laboratories.



LABORATORIES, INC.

1 INDUSTRIAL AVENUE, LOWELL, MASSACHUSETTS 01851. TEL. (617) 851-4111, TWX 710 343-6769. TELEX 94-7421

Printed in U.S.A.
13-210A

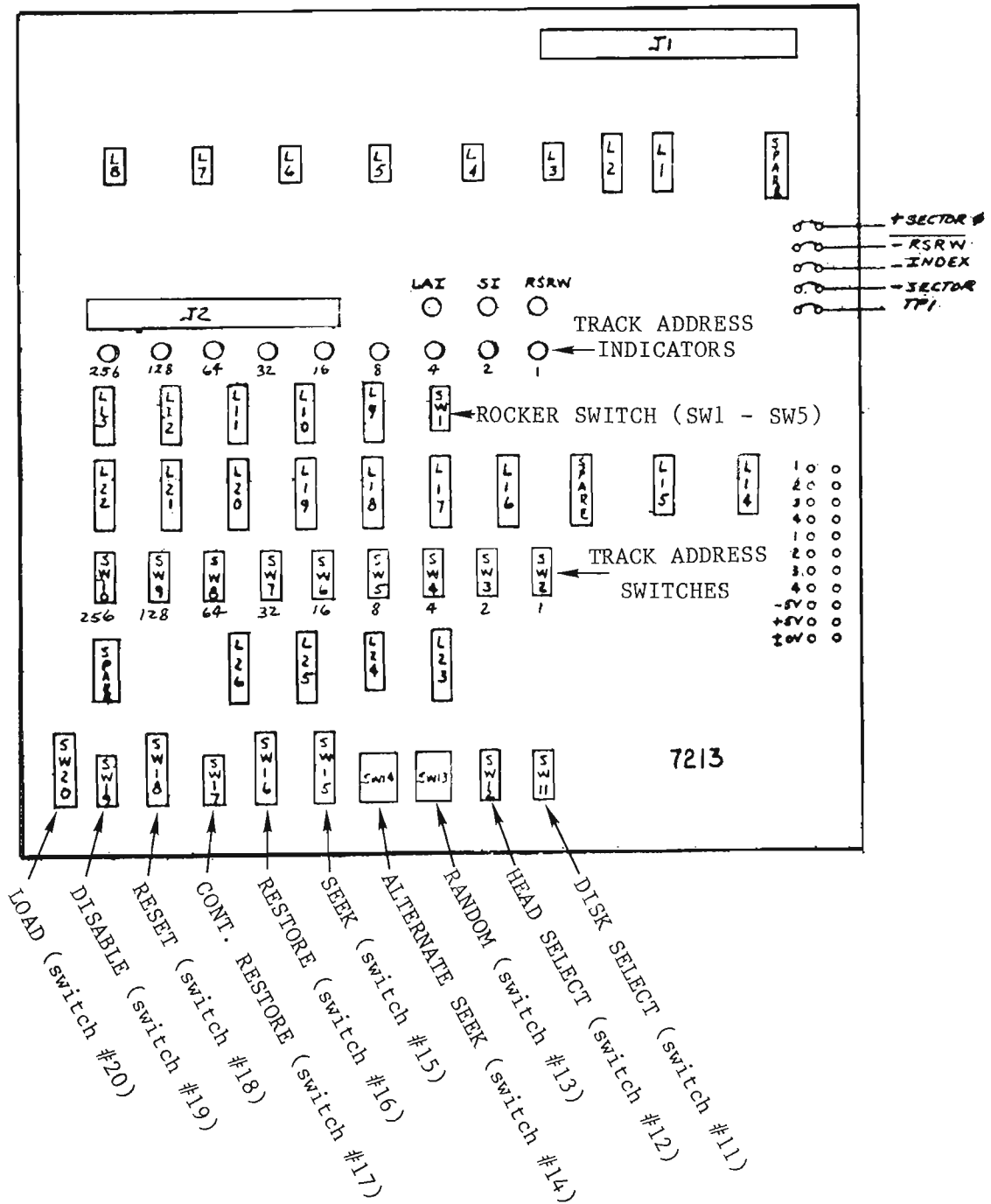

FIGURE 1 7213 DISK EXERCISER (LATEST REVISION)

4. RND - RANDOM TRACK GENERATOR (switch #13 in Figure 1) - When ON, a random track pattern is generated; when OFF, the random track generator is off.
5. ALTERNATE SEEK (switch #14 in Figure 1) - When ON, the head positioner will continuously seek between two addresses: the address set on switches TK1 through TK256, and the address loaded in the multiplexer of the exerciser board (by a LOAD operation).
6. SEEK (switch #15 in Figure 1) - Pressing this momentary contact switch will move the heads to the address set on switches TK1 through TK256.
7. RST - RESTORE (switch #16 in Figure 1) - Pressing this momentary contact switch will position the heads at track zero.
8. CONT. RST (switch #17 in Figure 1) - When ON, the heads are repeatedly positioned to track zero.

NOTE:

RST or CONT. RST will override the RND and ALTERNATE SEEK switches.

9. RESET (switch #18 in Figure 1) - This momentary contact switch resets the exerciser.
10. DISP - DISABLE (switch #19 in Figure 1) - When ON, the track address is disabled. The head will remain positioned wherever it is when the DISP switch is turned on.
11. LOAD (switch #20 in Figure 1) - This momentary contact switch loads the track address (selected by switches TK1 through TK256) into the multiplexer of the exerciser.

12. UNIT SELECT (switch #1 in Figure 1) - This 5-bank rocker switch has the following functions:
 - A. SW1 - Selects 100 TPI or 200 TPI for the random generator. During the random mode, switch 1 of rocker switch has control of the random generator. If SW1 is ON, the random address generated at any time will not be greater than 128. If SW1 is OFF, the random address can be greater than 128. This switch is active only when the RANDOM switch is on.
 - B. SW2 - Selects Unit 1.
 - C. SW3 - Selects Unit 2.
 - D. SW4 & SW5 - Not used.

The 7213 board has 12 LED indicators; nine of these LEDs indicate the selected track address (1 through 256). The remaining indicators are described below.

13. LAI - LOGICAL ADDRESS INTERLOCK - When ON, it indicates that an illegal track address has been selected. The maximum legal addresses are 203 for the Model 43, and 407 for the Models 44A/44B and CDC Hawk.
14. SI - SEEK INCOMPLETE - If ON, it indicates that the head did not move to the selected track address.
15. RSRW - READY/SEEK/READ/WRITE - When ON, it indicates that the disk drive is ready to do another Seek, Read, or Write operation.

The 7213 board has six cables.

1. The +5V cable with Molex connector is used to provide power to the 7213 board (used with CDC Hawks only).

2. The +5V cable with E-Z hook connector is used to provide power to the 7213 board (used with all Diablo Models).
3. The -5V cable provides the -5V that is needed to operate the amplifier of the 7213. It is used only during head alignments.
4. The GND cable provides +0V to the exerciser.
5. This head cable (see Figure 5B) plugs into the CDC Hawk or Diablo 44B heads.
6. This head cable (see Figure 5A) plugs into the Diablo Models 43 and 44A.

TEST POINTS

The 7213 has four test points.

1. INDEX - Index Mark coming from the disk.
2. RSRW - Monitors Drive Ready.
3. SECTOR MARK - Monitors Drive Sector marks.
4. SECTOR 0 - Time from Index to first sector, used to obtain index to sector compatibility.

INSTALLING THE 7213 EXERCISER FOR TESTING AND ALIGNMENT

DISK CABLES -- The 7213 exerciser board looks physically similar to the 210-6295 I/O board, used in the Wang portion of the Models 2230 and 2260. The J1 and J2 connectors are located in the same position on both of these boards, and the ribbon cables from the disk must be inserted into these connectors in the same order. To test a disk

J1 LONG CABLE
J2 SHORT CABLE

drive, simply unplug the ribbon cables from the 6295 board in the microprocessor and plug them into same connectors of the 7213 exerciser board. If a Daisy Chain cable (system to master in 2260-2) from the microprocessor is being used, select the drive by switches SW2 and SW3 of the rocker switch.

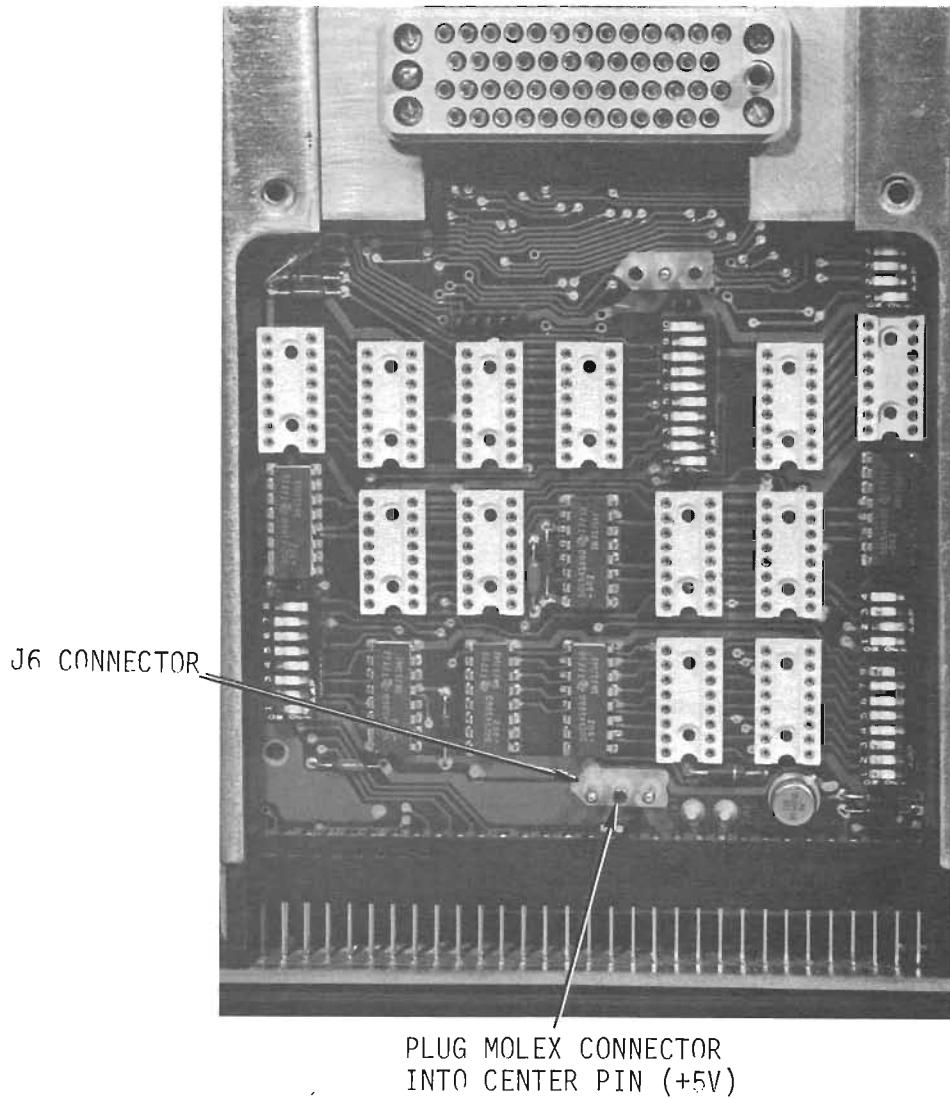

FIGURE 2 CDC HAWK WINCHESTER I/O BOARD

+5V CABLES -- The 7213 has two +5 volt cables: one with an E-Z hook connector and the other with a single pin Molex connector.

On all Diablo Model drives, attach the E-Z hook to the cathode side of the diode on the I/O PCB. On the Diablo 44B, this diode is located in the lower right corner of the I/O board, below the Winchester connectors. To locate the diode on the Diablo Models 43 and 44A, it will be necessary to remove the cover plate around the bottom Winchester connector, held in place by two screws.

The single pin Molex connector is used with the CDC Hawk disk drives. On the Winchester I/O board, connect the cable to the center pin of the three-pin connector (J6) as shown in Figure 2.

+5V - TOP TRACK OF ADDRESS LOGIC

-5V CABLES -- On the Diablo Models 43 and 44A, connect the -5 volt cable to the emitter of J22 on the R/W PCB. On the Diablo Model 44B, connect this cable to the junction of resistor M31 and transistor M33 on the servo board (artwork revision 12067) as shown in Figure 3A. If the servo board has artwork revision 12098, connect the -5V cable to pin 7 or 9 of H26 as shown in Figure 3B.

On the CDC Hawk drives connect the -5V cable to TP9 on the AGC Servo Preamp Board. See Figure 4.

HEAD CABLES -- The head cable connector shown in Figure 5A plugs into the upper or lower head cables of the Diablo Models 43 and 44A.

The head cable connector shown in Figure 5B plugs into the upper or lower head cables of the Diablo Model 44B and the CDC Hawk.

GND CABLE -- Connect the GND cable to logical +0V for all Models.

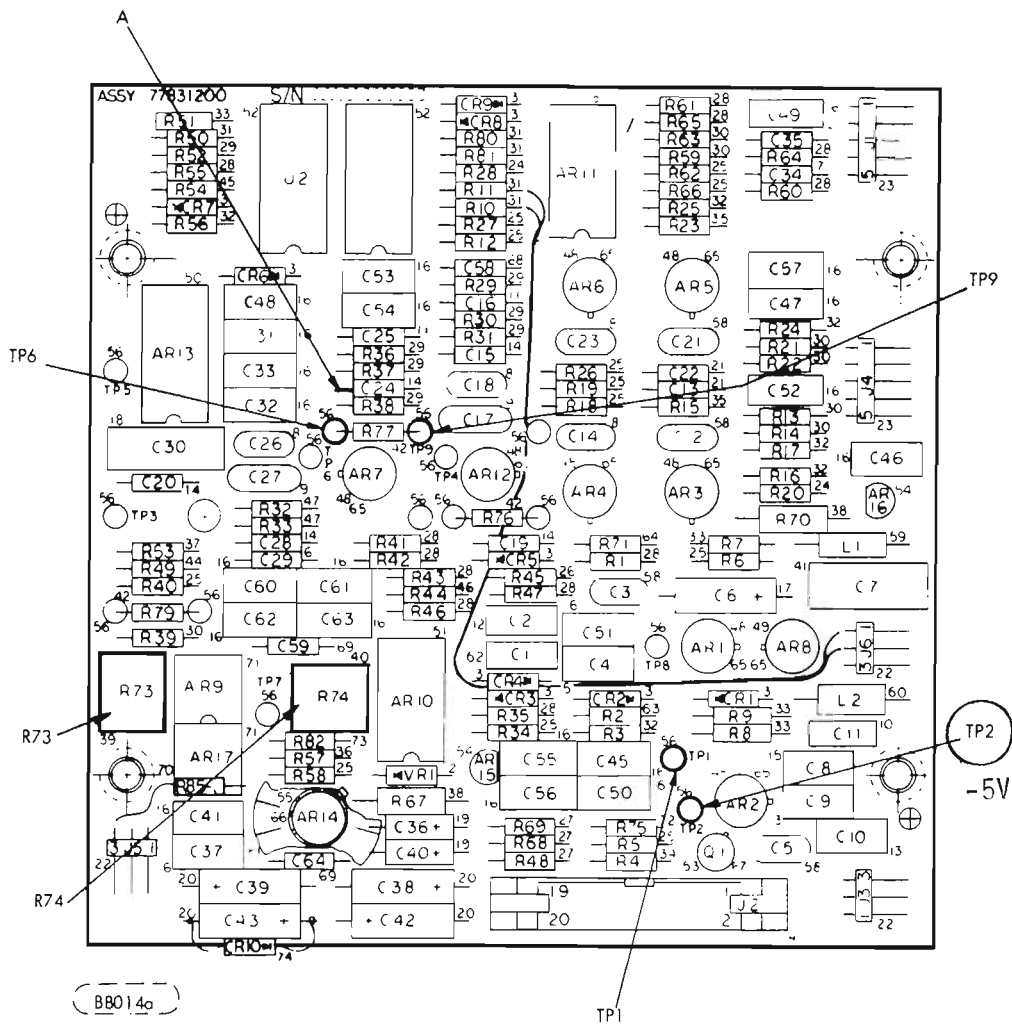

FIGURE 4 CDC HAWK SERVO PREAMP BOARD



A) DIABLO 43 & 44A
HEAD CABLE CONNECTOR

B) DIABLO 44B & CDC HAWK
HFAD CABLE CONNECTOR

FIGURE 5

PRE-OPERATION CHECK

1. Power off the drive.
2. Plug the ribbon cables into the exerciser.
3. Connect the +5 volt cable in its proper place.
4. Connect the +0V cable with E-Z hook.
5. Set all switches to the OFF position.
6. Power on the drive; when the drive loads the heads, the READY light (RSRW) will turn on.

The exerciser is now ready for operation.

SEEK OPERATION

1. Reset the exerciser.
2. Press the RST button (switch #16 in Figure 1) to restore the head positioner to track zero.
3. Set the Seek Address with address switches TK1 through TK256 and note address in address LED Display.
4. Press the Seek switch (switch #15 in Figure 1).

The drive should now seek to the address specified.

ALTERNATE SEEK

1. Reset the exerciser.
2. Press the RST button (switch #16 on in Figure 1) to restore the head positioner to track zero.
3. Select one seek address with switches TK1 through TK256.
4. Press the Load switch (switch #11 in Figure 1) to load this seek address into the multiplexer.
5. Select the other seek address with switches TK1 through TK256.
6. Turn the Alternate Seek switch ON (switch #14 in Figure 1).

The drive should now seek between the two selected addresses.

RANDOM SEEK

1. Reset the exerciser.
2. Press the RST button (switch #16 in Figure 1) to restore the head positioner to track zero.
3. Turn the RND switch ON (switch #13 in Figure 1) to select the Random Mode.

NOTE:

If the disk drive is a 100 TPI device, note that switch SW1 of the rocker switch must be ON to limit the seek addresses to 128 or less.

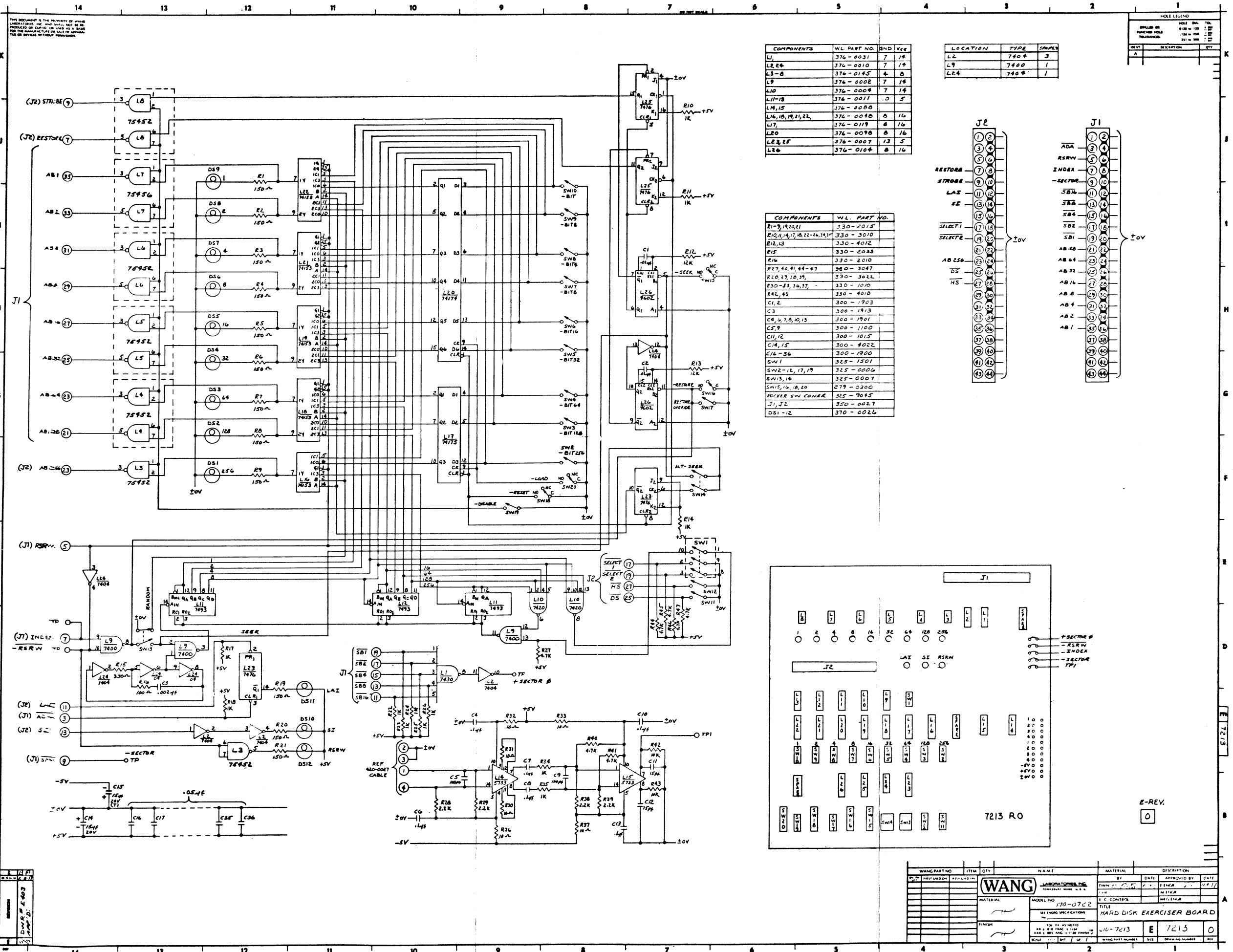

COMPONENTS	WL PART NO.	QTY	VEC
L1	376-0031	7	1/4
L2,4	376-0010	7	1/4
L3-8	376-0145	4	8
L9	376-0008	7	1/4
L10	376-0008	7	1/4
L11-13	376-0011	0	5
L14,15	376-0000	0	5
L16,18,19,21,22	376-0098	8	1/4
L17	376-0119	8	1/4
L20	376-0098	8	1/4
L23,24	376-0007	13	5
L25	376-0104	8	1/4

LOCATION	TYPE	QTY
L2	740#	3
L9	740#	1
L24	740#	1

COMPONENTS	WL PART NO.
R1-9,19,20,21	330-2015
R10,11,14,17,18,22-26,31,31'	330-3010
R12,13	330-4012
R15	330-2033
R16	330-2010
R27,40,41,44-47	330-3047
R28,29,30,39	330-3022
R30-33,34,37	330-1010
R42,43	330-4018
C1,2	300-1903
C3	300-1913
C4,7,8,10,13	300-1901
C5,9	300-1100
C11,12	300-1015
C14,15	300-4022
C16-36	300-1900
SW1	325-1501
SW2-12,17,19	325-0006
SW3,14	325-0007
SW15,16,18,20	279-0300
PECKER SW CONER	325-9045
J1,J2	350-0027
DS1-12	370-0026

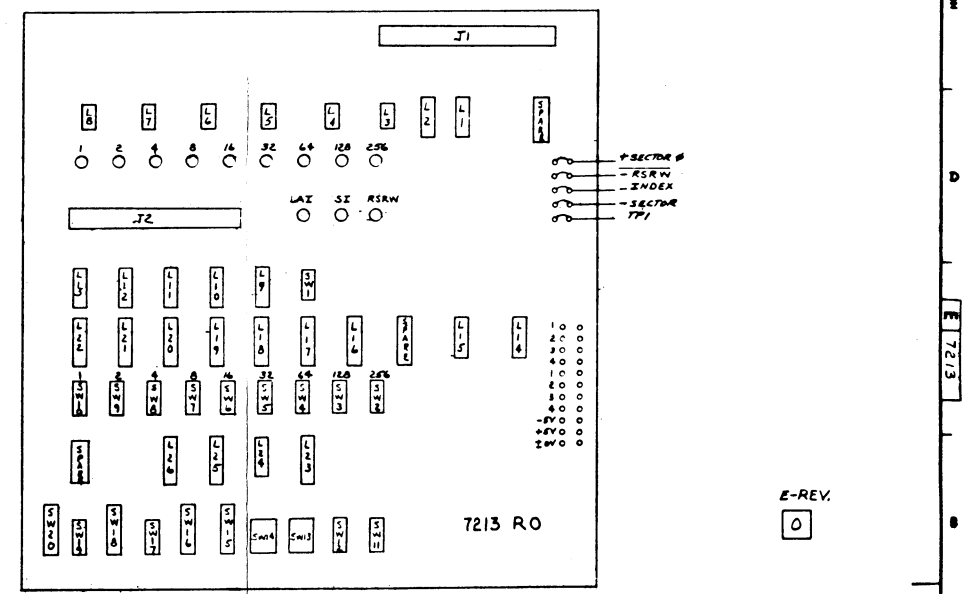
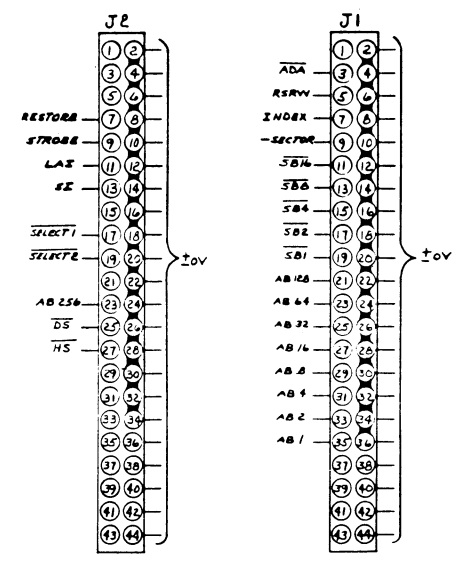

WANG PART NO.	ITEM	QTY	NAME	MATERIAL	DESCRIPTION
130-0728			HARD DISK EXERCISER BOARD		

THIS DOCUMENT IS THE PROPERTY OF WANG CORPORATION AND WILL NOT BE REPRODUCED OR COPIED IN WHOLE OR IN PART WITHOUT THE WRITTEN PERMISSION OF WANG CORPORATION.

REV.	DESCRIPTION	DATE
0		

E-REV. 0

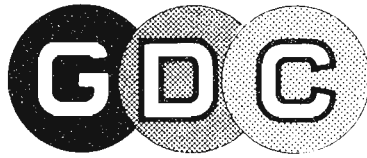

TRIBIT

ALIGNMENT CARTRIDGE

SPECIFICATIONS

&

USER'S MANUAL

PART NUMBERS

GDC 2315T

GDC 5440T

GENERAL DISK CORPORATION

3070 Scott Boulevard / Santa Clara, California 95050

Ph (408) 246-9434

I. SPECIFICATIONS

GDC Alignment Cartridges are single disk cartridges inspected to meet stringent GDC purchase specifications.

A. Head Alignment Track

A Head Alignment Track is prerecorded on each disk surface with the TRIBIT pattern shown in Figure 1. Each track has an allowable radial tolerance of ± 65 microinches when compared with a GDC master alignment cartridge.

B. Index Transducer Alignment Track

For Index Transducer Alignment, each disk surface is pre-recorded with a single flux transition marker located 180° from the index slot. At 1500 RPM, the marker pulse (Pulse A, Fig. 2) is prerecorded $30.0 \pm 3.0 \mu$ sec. after the leading edge of the index pulse. For easy identification, it is followed after 10μ sec. by 3.4 msec. long burst of pulses.

II. USER'S INSTRUCTIONS

A. Alignment Procedure

The GDC Alignment Cartridge shall be used for R/W head and index transducer alignment as described below.

1. Overwrite Protection

Activate the WRITE PROTECT option if the drive is so equipped; otherwise, exercise extreme caution during the alignment operation to avoid overwriting the alignment tracks.

2. Cleanliness

In addition to the cleanliness precautions stated in

the disk drive maintenance manual, it is important that the mating surfaces of the alignment cartridge and the disk drive be free of contaminants during the alignment procedure.

CAUTION

DO NOT USE A MATERIAL FOR CLEANING
THAT MAY TEAR OR LEAVE LINT.

The cartridge armature plate and locating cone can best be cleaned using the ball of the index and little fingers.

CAUTION

AN ALIGNMENT CARTRIDGE WHICH SHOWS
VISIBLE EVIDENCE OF DAMAGE TO THE
ARMATURE PLATE OR LOCATING CONE
(INCLUDING FLAKING PLATING) WILL
CAUSE ERRONEOUS ALIGNMENT.

3. Temperature Stabilization

Only after the disk drive has been temperature stabilized can the alignment cartridge stabilization be accomplished

a. Drive Temperature Stabilization

Time necessary for drive temperature stabilization requires one up to two hours of head loaded operation as per drive manufacturer's instructions.

b. Alignment Cartridge Temperature Stabilization

The time required for temperature stabilization of the alignment cartridge is dependent upon the cartridge storage environment.

(1) Storage in the Drive Operating Environment

If the cartridge storage temperature is essentially the same as the recommended machine operating environment, the cartridge shall be allowed to run in the drive with heads loaded for 15 minutes prior to attempting the alignment procedure.

(2) Storage in Other Than the Drive Operating Environment

If the cartridge storage temperature is essentially different from the recommended drive operating environment, the cartridge shall be allowed to run on the drive with heads loaded for 30 minutes. The cartridge shall be removed and reinstalled. Alignment shall proceed after an additional 15 minutes of drive operation with the heads loaded.

4. Hysteresis

In order to eliminate head positioner hysteresis (on disk drives where applicable) always approach the head alignment tracks from home or restore position.

5. R/W Head Alignment

Make certain that temperature stabilization has been achieved at the R/W head alignment cylinder specified in Table 1. Set the oscilloscope for internal triggering with the time base setting of 2 or 5 μ s/cm. Connect scope to the "Read" test point on the drive. NOTE: Should the read back signal be different than that shown in Fig. 1, it might be due to differential signal at the test point. To eliminate this problem, it may be necessary to use a test point electrically closer to the head output. Simplification of the head alignment procedure and complete overwrite protection is achieved by using the GDC Battery Powered Preamp into which the R/W head is plugged.

For head alignment, align peaks B and C to touch a common horizontal line. If vertical gain is used as shown in Fig. 3, head alignment within 10 microinches can be achieved.

Head off-track position is determined by adjusting the highest peaks of B or C to be 6 cm from ground (see Fig. 4). The difference between peak B and C expressed in centimeters is compared with Fig. 4.

Head off-track position:

100 TPI (6.7 mil head) 1 cm = 225 microinches
200 TPI (3.8 mil head) 1 cm = 125 microinches

For other track spacing - contact GDC. NOTE: GDC tribit cartridges can be used for any future track spacing without modification.

G. Index Transducer Alignment

Select index to burst cylinder for adjusting the index transducer. Set oscilloscope time base to 5 ms/cm while triggering externally from drive index.

Adjust the index transducer, or the index pulse delay as required until the peak of the single pulse is located at 30 ± 5 microseconds at 1,500 RPM or 19 ± 3 microseconds at 2,400 RPM from the leading edge of the index pulse.

Select the bottom head. The peak of the single pulse must be within 30 ± 5 microseconds or 19 ± 3 microseconds at 2,400 RPM. If not, readjust the index transducer until both heads are within specified limits. (See Fig. 2).

III. WARRANTY

GDC Alignment Cartridges are warranted against defective materials and workmanship for one (1) year from the date of shipment.

TABLE I

ALIGNMENT CARTRIDGE MODEL DISK DRIVES USED IN LOCATIONS OF ALIGNMENT CYLINDERS NUMBER OF SLOTS IN HUB

ALIGNMENT CARTRIDGE MODEL	DISK DRIVES USED IN	LOCATIONS OF ALIGNMENT CYLINDERS		NUMBER OF SLOTS IN HUB
		Head	Index Transducer	
GDC 2315T	100 or 200 TPI	105 or 210	100 or 200	Index slot and eight (8) sector slots.
	1100, 2200 BPI			
	1500, 2400 RPM			
GDC 5440T	100 or 200 TPI	073 or 146	100 TPI	Index slot only.
	1100, 2200 BPI		200 TPI	
	1500, 2400 RPM		005 201	

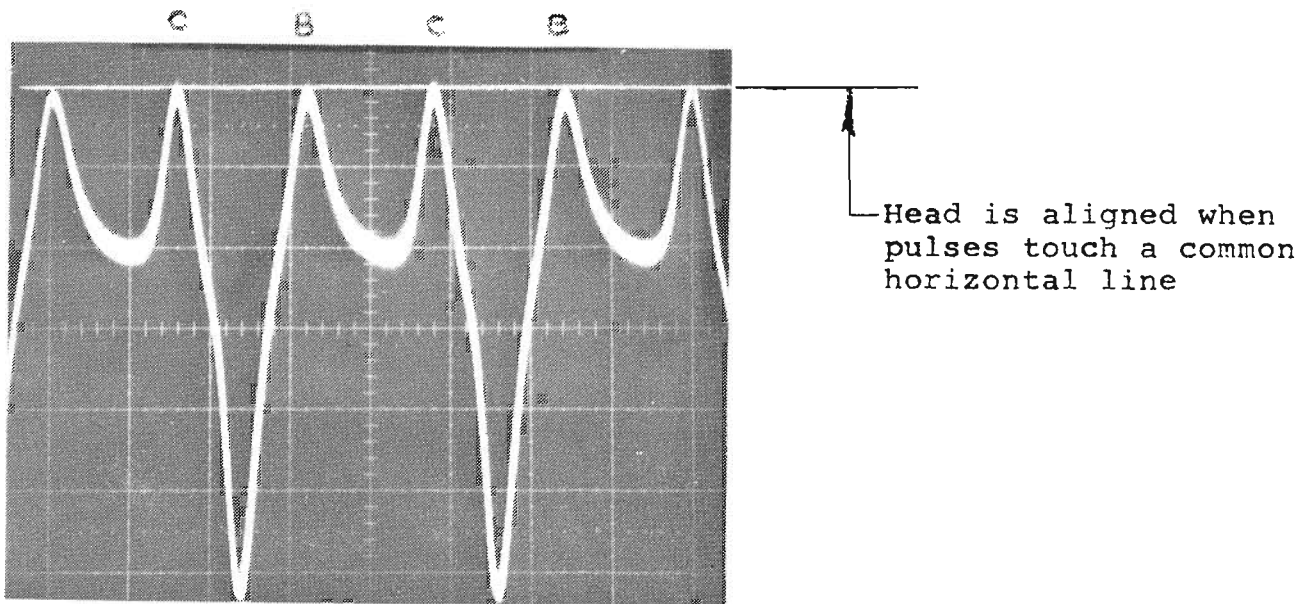

FIGURE 1
(Tribit pattern.)

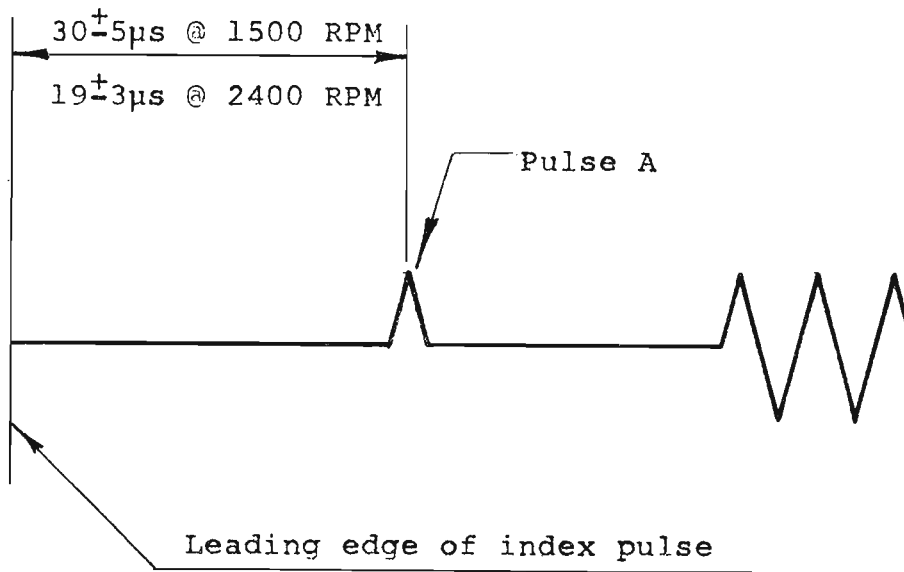

FIGURE 2
(Index transducer alignment.)

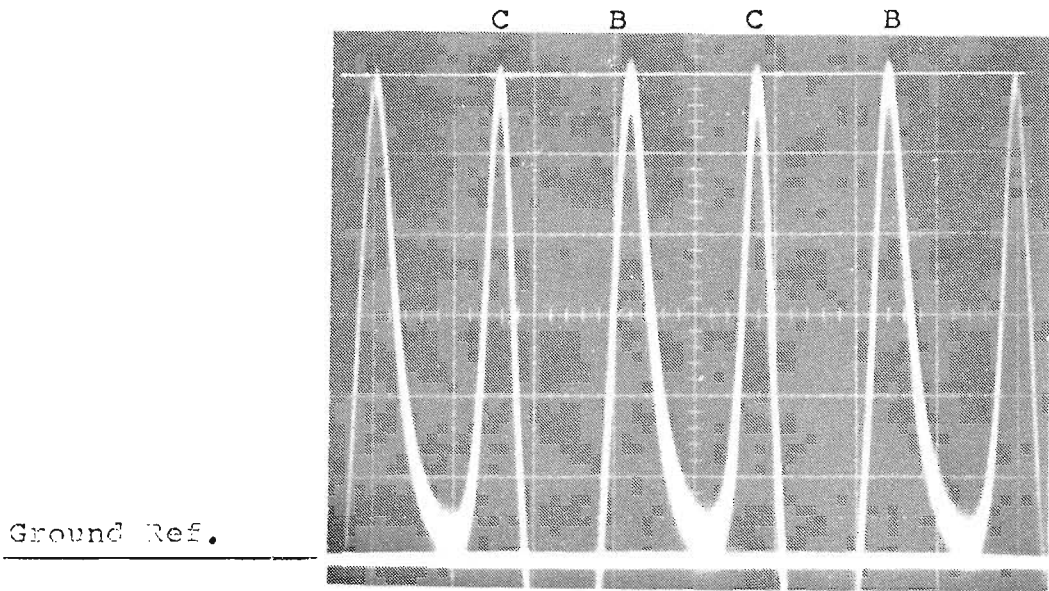

FIGURE 3
(Heads aligned)

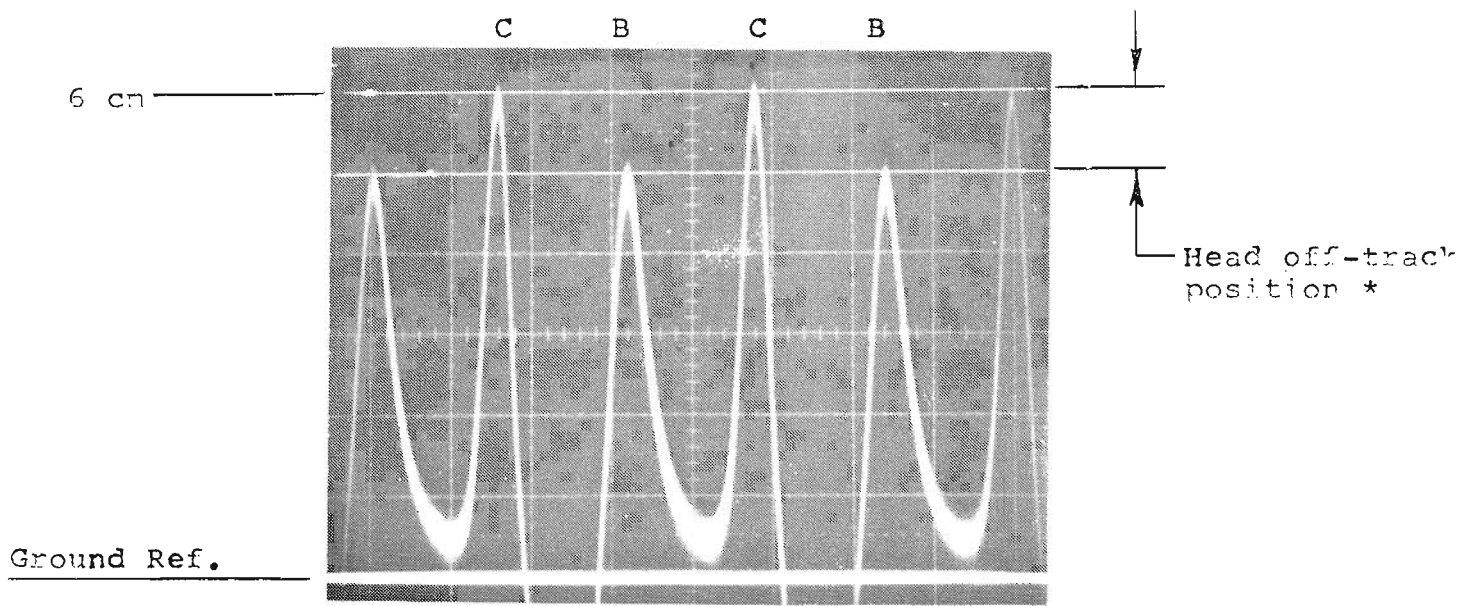

FIGURE 4
(Measuring head
off-track distance)

* Note: Head off-track position. (when Ground to the highest peaks B or C equals 6 cm.)

100 TPI	1 cm = 225 microinches
200 TPI	1 cm = 125 microinches

PRODUCT SERVICE NOTICE

DATE : November 12, 1981

CLASSIFICATION PERIPHERALS

CATEGORY DISK DRIVES

PRODUCT/APPL. GENERAL TECHNICAL

SEQUENCE # #1

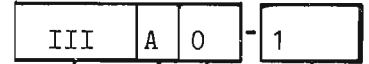

TITLE :

10 MEG CATSEYE ALIGNMENT PACKS

This PSN shows the waveforms which should be obtained when using the Catseye Alignment Pack for R/W head alignment on the 10 Megabit Diablo and Hawk disk drives.

NOTE

There is a new part number for the Catseye Alignment Pack. The new number is 726-8037.

Use of the Catseye Alignment Pack eliminates the need for the exerciser board (with its separate amplifier) that is required when using the Tri-bit Alignment Pack. The Catseye Alignment Pack generates a calibrated "catseye" pattern using the signals as read directly on the R/W heads.

When using the Catseye Alignment Pack, follow the same procedure (including the same track numbers and scope settings) that is used with the Tri-bit Alignment Pack. This procedure is found in the Diablo Model 44B Disk Drive Maintenance Manual.

Figure 1 shows the "catseye" oscilloscope pattern when the heads are properly aligned. The scope calibration used to obtain this pattern is as follows:

Vertical: 0.2 V/Div.
Horizontal: 1 ms/Div.



III.A.0-1

Figure 2 is the same waveform but with the horizontal sweep expanded to 0.5 ms/Div.

Figure 3 shows the index-to-data burst timing with calibration as follows:

Vertical: 50 mv/Div.
Horizontal: 2ms/Div.

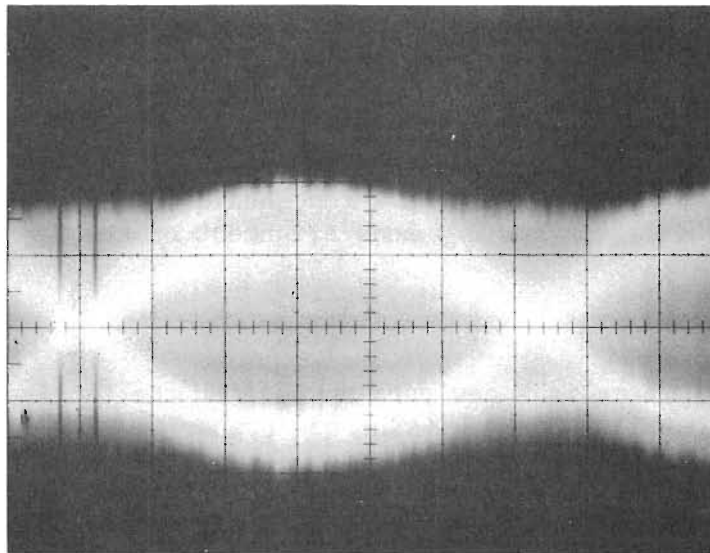

Figure 1 Heads Properly Aligned

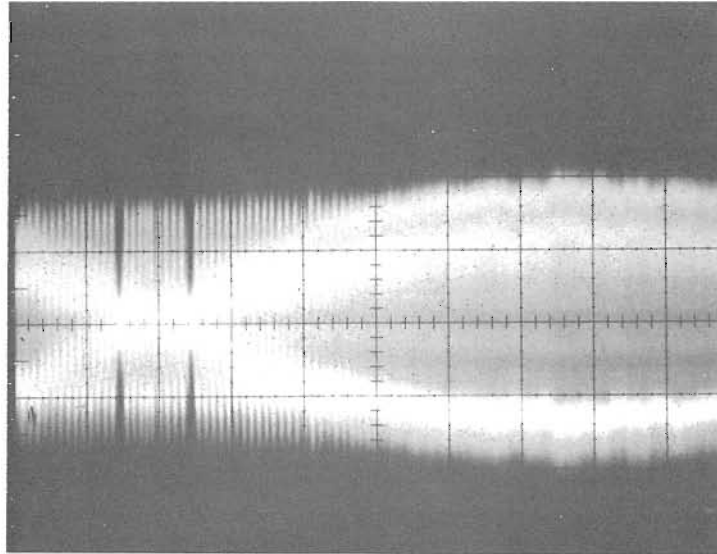

Figure 2 Heads Properly Aligned--(expanded sweep)

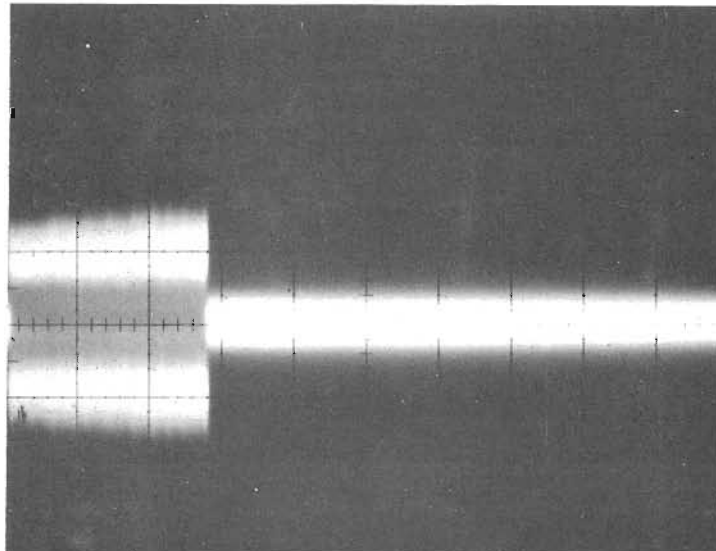

Figure 3 Index-to-Data Burst