

Customer Engineering Division

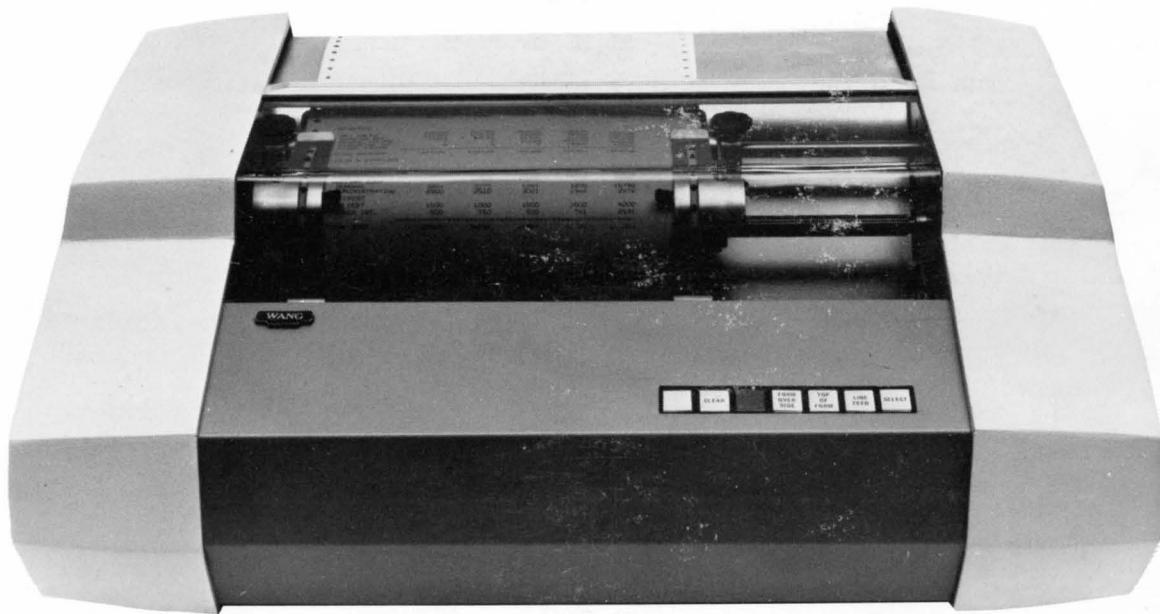

Model 61/62 Matrix Printer Maintenance Manual



Customer Engineering Division

Model 61/62 Matrix Printer

Maintenance Manual

© Wang Laboratories, Inc., 1978

NOTICE:

This document is the property of Wang Laboratories, Inc. Information contained herein is considered company proprietary information and its use is restricted solely to the purpose of assisting you in servicing Wang products. Reproduction of all or any part of this document is prohibited without the consent of Wang Laboratories.



LABORATORIES, INC.

ONE INDUSTRIAL AVENUE, LOWELL, MASSACHUSETTS 01851, TEL. (617) 851-4111, TWX 710 343-6769, TELEX 94-7421

THE
FEDERAL
BUREAU OF
INVESTIGATION

DEPARTMENT OF JUSTICE

COMMUNICATIONS SECTION

WASHINGTON, D.C. 20535

10/10/90

TO: SAC, NEW YORK
FROM: SAC, PHOENIX
SUBJECT: [Illegible]

PHOENIX, ARIZONA
[Illegible text and stamp]

TABLE OF CONTENTS

	<u>PAGE</u>
SECTION 1 INTRODUCTION	
1.1 SCOPE	1-1
1.2 MATRIX PRINTERS AND THEIR DIFFERENCES	1-2
1.3 UNIT DESCRIPTION	1-2
1.3.1 Print Head and Carriage	1-4
1.3.2 Inking	1-4
1.3.3 Paper Movement	1-4
1.3.4 Vertical Format Unit (VFU).....	1-5
1.3.5 Control Electronics	1-5
1.4 SPECIFICATIONS	1-6
1.5 PAPER SPECIFICATIONS.....	1-8
SECTION 2 INSTALLATION	
2.1 SITE CONSIDERATIONS	2-1
2.2 MATRIX PRINTER STAND (OPTION A).....	2-1
2.3 UNPACKING AND PACKING PROCEDURES.....	2-1
2.3.1 Unpacking	2-1
2.3.2 Packing	2-3
2.4 UNIT INSPECTION PROCEDURE	2-4
2.5 OPERATOR CONTROLS AND INDICATORS	2-5
2.5.1 Control Panel	2-5
2.5.2 Rear Panel	2-6
2.5.3 Printer Chassis	2-6
SECTION 3 OPERATION	
3.1 GENERAL	3-1
3.2 VERTICAL FORMAT UNIT (VFU)	3-1
3.3 RIBBON CARTRIDGE REMOVAL AND REPLACEMENT	3-4
3.3.1 Removal	3-4
3.3.2 Replacement	3-5

3.4	OPERATION OF 2231W VIA 2200 CPU	3-6
3.4.1	Device Address Codes	3-6
3.4.2	Select Statements	3-7
3.4.3	Line Length	3-10
3.4.4	Tab Function	3-11
3.4.5	Expand function: HEX (OE)	3-11
3.4.6	Zones	3-13
3.4.7	HEX Function	3-13
3.4.8	Control Codes	3-14
3.4.9	2231W-3 Operation with 2282 Graphic CRT	3-16

SECTION 4 THEORY OF OPERATION

4.1	INTRODUCTION	4-1
4.2	GENERAL	4-1
4.3	GENERAL OPERATION	4-3
4.3.1	Carriage Movement and Print Timing	4-3
4.3.2	Servomotor Logic	4-4
4.3.3	Paper Movement	4-5
4.3.4	Paper Feed Logic	4-6
4.3.5	Print Operation	4-7
4.3.6	I/O Control and Character Storage	4-8
4.4	DETAILED THEORY OF OPERATION	
4.4.1	Timing and Printing Control	4-10
4.4.1.1	Carriage Movement Detailed	4-10
4.4.1.2	Paper Movement	4-14
4.4.1.3	Print Operation	4-15
4.4.1.4	I/O Control and Data Storage	4-17
4.4.1.5	Prime Circuits Operation	4-18
4.4.1.6	Marker Bit Circuits	4-19
4.4.1.7	Select Circuit Operation	4-20
4.4.1.8	Print Buffer Loading Operation	4-21
4.4.1.9	Ready/Busy Circuit Operation	4-21
4.4.1.10	Print Cycle Operation	4-23
4.4.1.11	Audio Alarm Operation	4-24
4.4.1.12	Cover Open Operation	4-25

4.4.1.13	Paper-Out Switch Operation	4-25
4.4.1.14	Form Override Operation	4-25
4.4.1.15	Servo Alarm Light Circuit Operation	4-25
4.5	2231W-3 PRINTING AND PLOTTING OPERATION	4-26
4.5.1	Conventional Printing	4-27
4.5.2	Plotting Mode	4-27

SECTION 5 ADJUSTMENT, REMOVAL AND REPLACEMENT PROCEDURES

5.1	INTRODUCTION	5-1
5.2	ELECTRICAL ADJUSTMENTS	5-1
5.3	MECHANICAL AND ELECTROMECHANICAL ADJUSTMENTS, REMOVAL/REPLACEMENT INDEX FOR 2231W-1,-2,-3	5-6
5.3.1	Paper Guides	5-7
5.3.1.1	Adjustment Checks	5-7
5.3.1.2	Adjustment	5-8
5.3.1.3	Removal and Replacement	5-8
5.3.2	Head Adjustment Arm	5-8
5.3.2.1	Adjustment Check	5-8
5.3.2.2	Adjustment	5-9
5.3.2.3	Removal and Replacement	5-9
5.3.3	Striker Plate and Platen Brackets	5-9
5.3.3.1	Adjustment Check	5-9
5.3.3.2	Adjustment	5-9
5.3.3.3	Striker Bar Removal and Replacement	5-11
5.3.4	Main Drive Belt	5-11
5.3.4.1	Adjustment Check	5-11
5.3.4.2	Adjustment	5-11
5.3.4.3	Removal and Replacement	5-12
5.3.5	Print Head Adjustment	5-12
5.3.5.1	Adjustment Check	5-12
5.3.5.2	Adjustment of Print Head	5-13
5.3.5.3	Solenoid Removal and Replacement	5-15
5.3.6	Ribbon Clutch Assembly and Cartridge Guides	5-17
5.3.6.1	Adjustment Check	5-17
5.3.6.2	Adjustment	5-17
5.3.6.3	Removal and Replacement.....	5-19

5.3.7	Reed Switches and Mounting Bracket	5-19
5.3.7.1	Adjustment Check	5-19
5.3.7.2	Adjustment	5-21
5.3.7.3	Removal and Replacement.....	5-22
5.3.8	Reed Switches Magnet	5-22
5.3.8.1	Adjustment Check	5-23
5.3.8.2	Adjustment	5-23
5.3.8.3	Removal and Replacement	5-23
5.3.9	Magnet Reluctance Pickup and Timing Disk	5-23
5.3.9.1	Adjustment Check	5-23
5.3.9.2	Adjustment	5-24
5.3.9.3	Removal and Replacement	5-25
5.3.10	Paper Feed Sprockets and Paper Guide Cover	5-25
5.3.10.1	Adjustment Check	5-25
5.3.10.2	Adjustment	5-25
5.3.10.3	Removal and Replacement	5-27
5.3.11	Horizontal Vernier Clutch (Paper Advance)	5-28
5.3.11.1	Adjustment Check	5-28
5.3.11.2	Adjustment	5-28
5.3.11.3	Removal and Replacement	5-28
5.3.12	Paper Movement Gears	5-29
5.3.12.1	Adjustment Check	5-29
5.3.12.2	Adjustment	5-30
5.3.12.3	Removal and Replacement	5-30
5.3.13	Vertical Format Unit	5-31
5.3.13.1	Adjustment Check	5-31
5.3.13.2	Adjustment	5-31
5.3.13.3	Removal and Replacement	5-34
5.3.14	Carriage Servomotor Removal and Replacement	5-34
5.3.15	Carriage Assembly Removal and Replacement	5-36
5.3.16	Electronic Assembly Cover Removal and Replacement...	5-36
5.3.17	Cover Removal and Replacement	5-36

SECTION 6 MAINTENANCE

6.1	INTRODUCTION	6-1
6.2	DIAGNOSTICS	6-1
6.2.1	2231W Diagnostic	6-2
6.2.2	Description of Command 2231W-1,-2,-3 Diagnostic	6-2
6.2.3	Looping Diagnostics for Scoping	6-4
6.2.4	2231W-3 Printer Diagnostic	6-11
6.2.5	Overall System Tests	6-11
6.2.5.1	Menu for Troubleshooting Tests	6-11
6.3	PREVENTIVE MAINTENANCE	6-12
6.3.1	Lubrication (Quarterly)	6-12
6.4	TROUBLESHOOTING	6-13
6.4.1	Troubleshooting Hints	6-13
6.5	115VAC/230VAC CONVERSION	6-18
6.6	RECOMMENDED SPARE PARTS LIST	6-18
6.7	PRINTER CABLES	6-18

SECTION 7 SCHEMATICS

<u>2231W-1,-2</u>	<u>2231W-3</u>	<u>DRAWING</u>
6761	6794	Timing and Format Control
7060	6795	I/O Data Storage
6756	6756	Power Drive Board
6758	6758	Print Head Finger Board
6757	7157	Mother Board
6759	6759	Print Head Cable Finger Board
7062	7062	Center Panel Fingerboard (6X2)
7063	7063	Reed Switch Fingerboard (5X2)
7064	7064	Format Control Fingerboard (4X2)
6762	6762	Panel Switch Board
6749	6749	Power Selection Switch (115/230V)

SECTION 8 MECHNICAL ASSEMBLY DRAWINGS

8.1	INTRODUCTION	8-1
8.2	PRINT HEAD ASSEMBLY	8-1
8.3	PAPER GUIDE COVER ASSEMBLY	8-1
8.4	LOWER PAPER GUIDE ASSEMBLY	8-3
8.5	COVER ASSEMBLY	8-5
8.6	RIGHT HAND SIDE FRAME ASSEMBLY	8-9
8.7	SHAFT ASSEMBLIES	8-12
8.8	LEFT HAND SIDE FRAME ASSEMBLY	8-15
8.9	CARRIAGE ASSEMBLY	8-18
8.10	FORMAT CONTROL ASSEMBLY	8-20
8.11	CHASSIS ASSEMBLY	8-22

SECTION 9 APPENDICES

HEXADECIMAL CODES	9-2
SIGNAL MNEMONICS	9-3

LIST OF ILLUSTRATIONS

<u>FIG. NO.</u>	<u>TITLE</u>	<u>PAGE</u>
1-1	Matrix Printers	1-3
2-1	Unpacking the Printer	2-2
2-2	Removal of Packaging Tape	2-3
2-3	Control Panel	2-5
2-4	Rear Panel	2-6
2-5	Typical Installations	2-7
3-1	Vertical Format Tape	3-3
3-2	Tape Flow and Splicing Square	3-3
3-3	Head Adjustment Arm	3-4
4-1	Basic Block Diagram	4-2
4-2	Carriage Movement	4-2
4-3	Paper Movement	4-5
4-4	Print Operation	4-8
4-5	I/O Control and Character Storage	4-9
4-6	Window Stroke (WS) Adjustment	4-12
4-7	Print timing Diagram	4-13
4-8	Marker Bit Generator	4-19
5-1	WS Timing Adjustment	5-3
5-2	Electrical Chassis Assembly Layout	5-5
5-3	Paper Guide Assembly	5-7
5-4	Head Adjustment Arm Assembly	5-8
5-5	Striker Bar Adjustment	5-10
5-6	Main Drive Belt Adjustment	5-12
5-7	Main Drive Belt Removal	5-13
5-8	Solenoid Wire Adjustment	5-14
5-9	Identification of Solenoids	5-14
5-10	Removal and Replacement of Solenoids	5-14
5-11	Carriage Assembly	5-18
5-12	Ribbon Drive	5-18
5-13	Ribbon Advance Cable	5-18
5-14	Reed Switches and Mounting Bracket	5-20
5-15	Reed Switch Magnet	5-20
5-16	First Character Position Adjustment	5-24
5-17	Magnetic Pickup Adjustment	5-24
5-18	Sprocket Adjustment (Disengaged)	5-26
5-19	Paper Guide Cover	5-26
5-20	Sprocket Adjustment (Engaged)	5-26
5-21	Paper Movement Adjustment	5-30
5-22	Vertical Format Housing Adjustment	5-33
5-23	VFU and Stepper Motor Phase Check	5-33
5-24	Vertical Format Unit	5-35

NOTE:

See Section 7 Title Page for Schematic Listing.

See Section 8 Title Page for exploded view mechanical drawings.

LIST OF TABLES

TABLE

TABLE

PAGE

1-1
6-1

Printer Differences
Troubleshooting

1-2
6-13

SECTION I
INTRODUCTION

1.1 SCOPE

This manual provides field maintainance information for the following versions of the 2231W low-cost printer: Model 61 - 10 pitch (2231W-1), Model 62 - 12 pitch (2231W - 2), and the 2231W-3 Graphic Display Printer, Model 63.

The manual is arranged in the following manner:

- SECTION 1: Introduction: Provides the reader with the scope of this manual, a general description, and specifications for the three versions of the matrix printer.
- SECTION 2: Installation: Contains instructions for unpacking, set up, and checkout of the matrix printer. Basic configuration for the three machines are also shown. Describes the function of all operator controls and indicators.
- SECTION 3: Operation: Included are the basic CPU operations required to operate each version of the 2231W matrix printer and operation of the VFU assembly.
- SECTION 4: Theory of Operation: Explanations of the electronic and mechanical assemblies are provided in sufficient detail to aid in maintaining the matrix printers.
- SECTION 5: Adjustments and Replacements Procedures.
- SECTION 6: Maintenance: Includes diagnostics, preventive maintenance, and troubleshooting information.
- SECTION 7: Schematics: Contains a set of electronic schematics and wiring and interconnection diagrams.
- SECTION 8: Mechanical Assembly Drawings: Allows the user to identify the mechanical parts of the matrix printer.
- SECTION 9: Hexidecimal Codes and Signal Mnemonics.

1.2 MATRIX PRINTERS AND THEIR DIFFERENCES

Mechanically, the three models are basically identical (See Figure 1-1). Electrically they are also nearly the same for the conventional printing functions; however, the 2231W-3 model has a graphic display capability as well as the conventional printing function as shown in Table 1-1.

TABLE 1-1
PRINTER DIFFERENCES

<u>MODEL</u>	<u>2231W-1</u>	<u>2231W-2</u>	<u>2231W-3</u>
Pitch	10 p.	12 p.	14.4 p.
Characters/ Second	120	120	120
Plotting Dot Configuration	N/A	N/A	800 X 8 dot strips

NOTE: An expanded feature doubles the width of the characters (14W X 9H Matrix).

Each printer contains a print head and carrier assembly, an inking medium, a paper movement mechanism, a Vertical Format Unit, and control electronics. The 31W-1, 31W-2, and 31W-3 print upper and lower case ASCII characters. The 31W-3 also prints the graphics displayed on a 2282 Graphic Display Terminal (CRT).

1.3 UNIT DESCRIPTION

The printers use a matrix-impact-printing technique that generates printed characters with dots in matrix form. The characters are composed of a 7w X 9h dot matrix and the matrix for graphics is the 800 X 8 dots per line. The printers operate at a rate of 120 characters per second and can achieve a rate of 40 to 250 lines per minute depending upon line length.

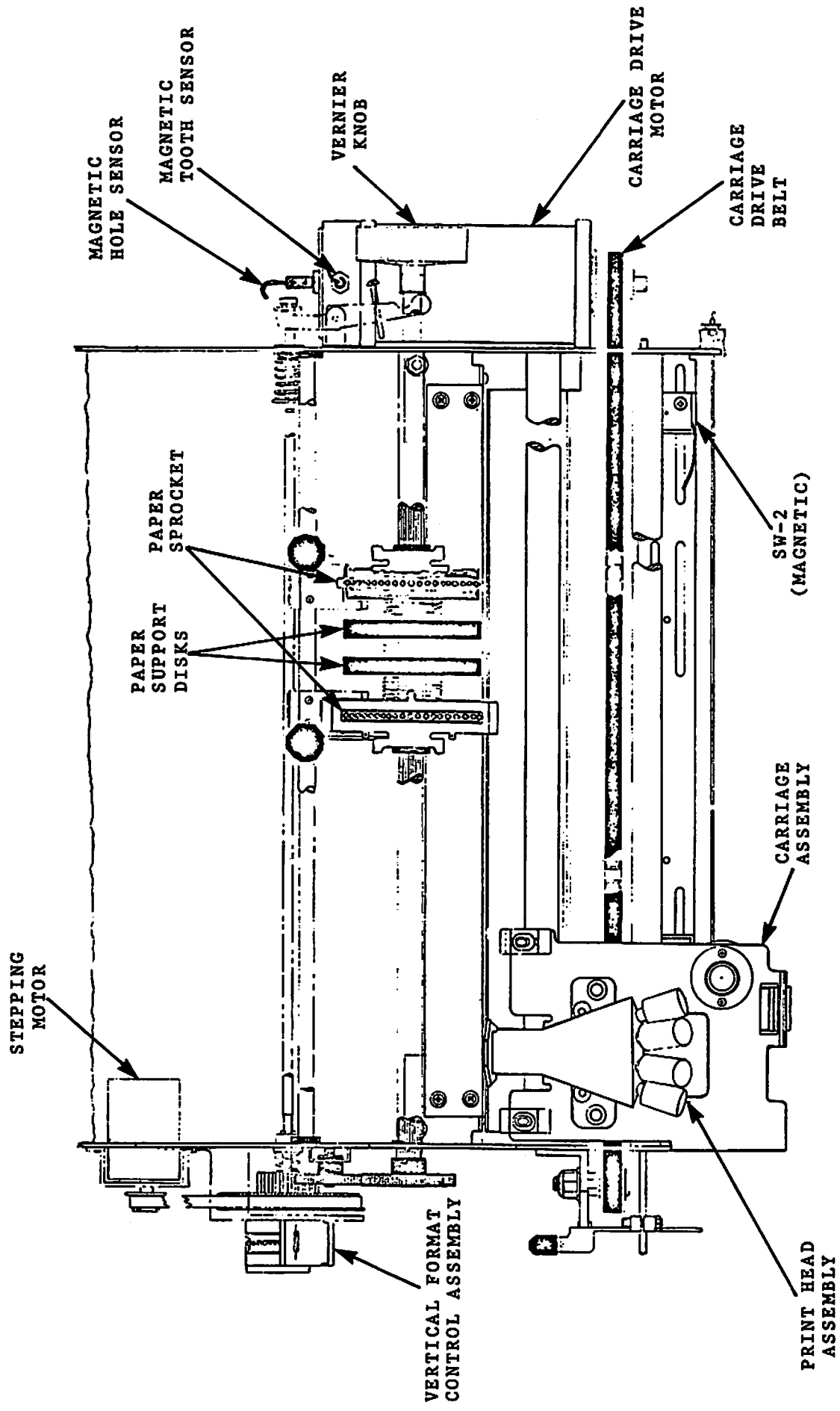

FIGURE 1-1 MATRIX PRINTERS

1.3.1 Print Head and Carriage

Printing is accomplished by firing selected solenoids on the print head as the carriage moves from left-to-right across the paper. When a solenoid is fired, the attached print wire is extended impacting against the ribbon which prints a dot on the paper. Two magnetic reluctance sensors and a timing disk provide electronic signals which are used to control print head motion and print timing.

1.3.2 Inking

The printers contain a mobius strip, fabric ribbon cartridge. As the print head moves from left-to-right, the ribbon is advanced by a pulley mounted under the carriage. The pulley mechanism disengages from the ribbon cartridge as the carriage returns to the left side of the paper.

As any particular spot on the ribbon passes the print head and re-enters the ribbon cartridge, the looped ribbon is flipped over so that both sides of the ribbon are used as it rotates in one direction.

1.3.3 Paper Movement

Continuous-form paper, of widths from 4 to 12.8 inches (10.2 to 32.4 cm), can be used in the printer as the distance between the two pin-feed mechanisms is continuously adjustable over the above range.

A stepping motor, geared to the pin-feed units, is used to advance the paper.

The stepping motor is activated by either a carriage return or by program control. The stepping motor may advance the paper one line, or the Vertical Format Unit may be used to halt the stepping motor at the end of a formatted distance of paper advancement.

1.3.4. Vertical Format Unit (VFU)

The Vertical Format Unit is a punched tape reader which uses a punched paper tape to automatically control paper movement. Under program control or manual operation of control panel switches, the VFU will advance the paper to the next vertical tab stop or top-of-form stop. The tape and paper are advanced simultaneously by the stepping motor.

1.3.5 Control Electronics

The control electronics are located on printed circuit boards in the rear of the printer. These boards contain a line buffer, function decoder logic, character generator, and power driver circuits.

1.4 SPECIFICATIONS

	<u>MODELS</u>		
	<u>2231W-1</u>	<u>2231W-2</u>	<u>2231W-3</u>
Printer Size			
Height	10 inches (26 cm)	Same	Same
Width	24 inches (61 cm)		
Depth	18 inches (46 cm)		
Weight	68 lbs (38.4 KG)	Same	Same
Speed	120 Char/Sec 40-250 LPM	Same	Same
Graphic Image Reproduction Time	N/A	N/A	105 seconds
Character Set	Upper & Lower ASCII (96 characters)	Same	ASCII, also dots for graphics
Character Configuration	7 dots wide 9 dots high	7 dots wide 9 dots high	7 dots wide 9 dots high
Plotting Configuration	N/A	N/A	800 X 8 dot strips
Line width	112 Characters	119 Characters	132 Characters
Vertical Spacing	6 lines/inch	Same	Same
Ribbon	Mobius Strip Cartridge	Same	Same
Switches/Lamps	ON/OFF, SELECT FORM OVERRIDE, TOP OF FORM, LINE FEED	Same	Same

MODELS

Specifications (Cont'd)	<u>2231W-1</u>	<u>2231W-2</u>	<u>2231W-3</u>
Vertical Format Control	2 Channel Standard 1 inch (2.54 cm) Tape	Same	Same
Power Requirements	115 or 230 VAC 50/60 Hz 140 Watts	Same	Same
Fuses	1.5A (SB) for 115 VAC, 8/10A (SB) for 230 VAC, 2.5A (SB) for Carriage Motor	Same	Same
Operating Environment	50° to 90°F (10 to 32°C) 40 to 80% relative Humidity, non condensing allowable 40 to 65% recommended	Same	Same
Operating Temp.	50° to 90°F (10 to 32°C)	Same	Same
Storage Temp.	40° to 130° F (8 to 55° C)	Same	Same

1.5 PAPER SPECIFICATIONS

If paper does not conform to these specifications, degraded forms handling can occur.)

1. Material must be margin-perforated, fanfold paper or card stock; perforations are used for guiding by pin-feed mechanisms.
2. Maximum form length is not to exceed 11 in. (37.9 cm).
3. Paper stock:
 - a. For single part forms, use 15-to 20-lb bond (20 lb for improved forms handling).
 - b. For multipart forms use:
 - 2 ply: 15/15 lb bond, 7 lb carbon
 - 3 ply: 15/12/15 lb bond, 7 lb carbon
 - 4 ply: 12/12/12/15 lb bond, 7 lb carbon
 - 5 ply: 12/12/12/12/15 lb bond, 5 lb carbon(up to four copies in addition to the original can be used)
 - c. Form width must be:
 - 3 1/2 in. (8.9 cm) minimum.
 - 13 1/2 in. (34.3 cm) maximum (edge-to-edge).
4. Fastening of multipart forms:
 - a. Improved multipart paper handling can be achieved with glued margins.

- b. Multipart forms must otherwise be fastened with crimps every two inches (5.1 cm) along both edges of the forms. NCR or other specialty paper can be fastened up to four parts of the form length.
 - c. Crimp must not come closer to the fanfold than 0.50 in. (1.27 cm).
 - d. Each crimp must have four prongs, two to enter both form and carbon and two to enter forms only. Card stock should be tested first.
5. Forms thickness:
- a. Maximum in the print area: 0.018 in. (0.046 cm) (allows for four 12-lb, one 15-lb and four 7-lb carbon parts).
 - b. Over crimps in the pin-feed margin: 0.030 in. (0.076 cm).
6. Sprocket holes:
- a. Must run along both margins $0.25 \pm .03$ in. (0.635 ± 0.076 cm) from paper edge to the hole center lines.
 - b. Distance between hole centers along the margins must be 0.5 ± 0.005 in. (1.27 ± 0.013 cm) non-accumulative in any 5 in. (12.7 cm) length.
 - c. Hole diameters must be 0.156 ± 0.005 in. (0.396 ± 0.013 cm). The two top and bottom drive holes on each sheet (four per sheet) can be up to 0.200 in. (0.508 cm) in diameter to permit post or ring binding of output.

- d. Distance between hole centers across the sheet must be uniform within 0.015 in. (0.038 cm) to a maximum of 12 5/16 in. (31.27 cm).
7. When using forms with wide and narrow copies in the same set, the top copy should always be the fullest width.
8. For pre-printed forms:
 - a. Pin-hole center to left side of left-most character cannot be less than $\frac{3}{8} + \frac{1}{16}$ in. (1.0 + 0.2 cm).
 - b. Pin-hole center to right side of last character cannot be less than $\frac{3}{8} + \frac{1}{16}$ in. (1.0 + 0.2 cm).

SECTION 2
INSTALLATION

2.1 SITE CONSIDERATIONS

If the printer is to be used without the stand, it must be placed on a table with the front edge of the printer overhanging and paralleled to the front edge of the table. The ventilation fan intake screen must not be obstructed by any objects which could reduce normal airflow. For environmental temperature, humidity, etc., see Technical Characteristics in Paragraph 1.4 of Section 1.

2.2 MATRIX PRINTER STAND (OPTIONAL)

The 2231W Matrix Printer has paper feed guides which permit the paper to be fed to the printer from the bottom or the front.

2.3 UNPACKING AND PACKING PROCEDURES

2.3.1 Unpacking (See Figure 2-1)

- 1) Open top of box and remove cardboard spacer placed around printer.
- 2) Remove jiffy bag from carton.
- 3) Remove printer from box.
- 4) Remove four foam blocks from corners of plywood base.
- 5) Place the printer on a table surface and remove plastic covering from the printer.

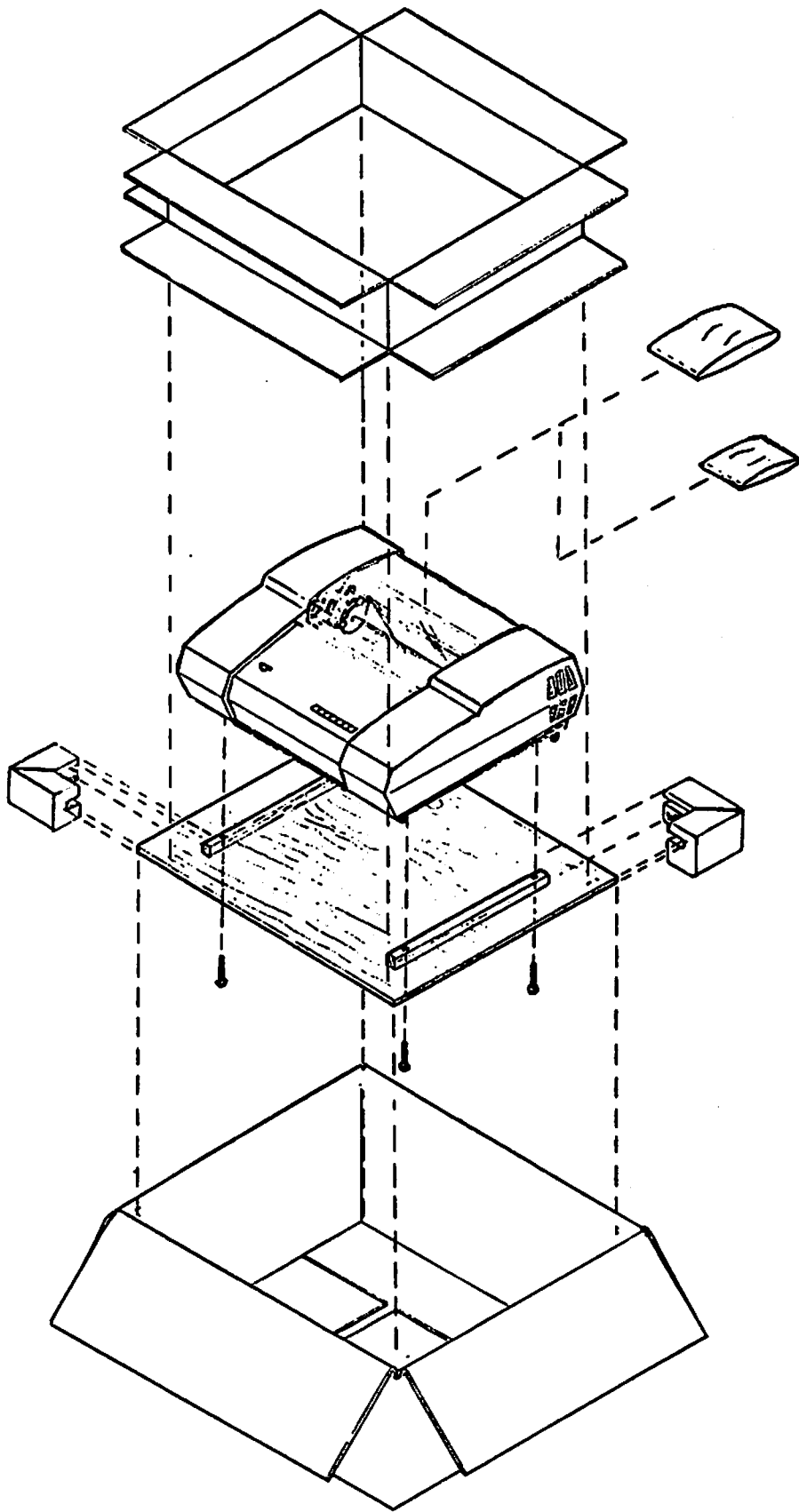

FIGURE 2-1 UNPACKING THE PRINTER

- 6) Extend one corner of the printer over the edge of the table. Remove the shipping bolt recessed in that corner of the plywood. Repeat for the remaining three corners.
- 7) Slide the printer off the plywood base onto the table.
- 8) Remove the tape securing the printer cover.
- 9) Lift the cover (front lifts upward toward the rear) to remove the tape from the following areas: (Refer to Figure 2-2)).
 - a. Paper Tape Reader "A"
 - b. Left and Right Paper Feed Units "B"
 - c. Print Head "C"
- 10) Remove I/O cable & ribbon cartridge from jiffy bag. Install ribbon cartridge (Section 3.3.2) and close cover.

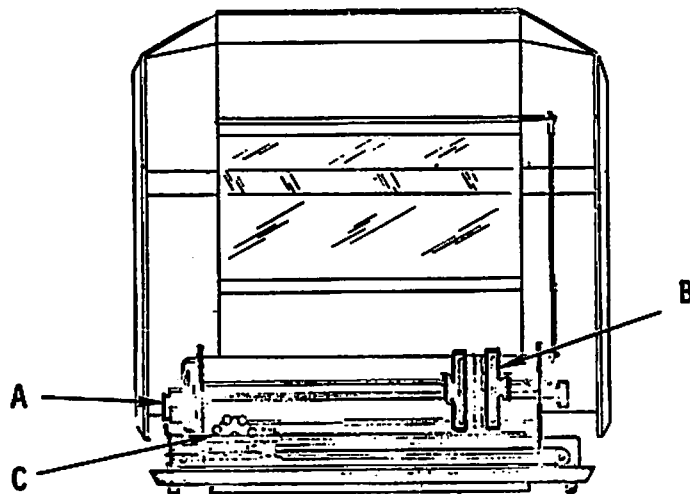

FIGURE 2-2 REMOVAL OF PACKAGING TAPE

2.3.2 Packing

Reverse steps 2 through 10 of the unpacking procedure, 2.3.1.

2.4 UNIT INSPECTION PROCEDURE

- 1) Lift cover, front to rear. The cover is connected to the chassis via wiring cable attached to the keyboard.
- 2) With the interior completely visible, inspect all parts of the printer. Look for any unusual conditions. The following list is a suggested procedure. If any faults are found that require replacement or adjustment, refer to Section 5 of this manual.

WARNING

No power is to be applied to the printer during this inspection.

- (a) Inspect the wiring to all three reed switches prior to checking the timing disk and magnetic reluctance pickups. Be sure that the pickups and timing disk do not make contact.
- (b) Check for damaged or loose parts. Make sure ribbon advance cable is properly seated on the ribbon drive pulley. Slowly move the carriage from left to right while observing the ribbon assembly for proper operation of pulley and ribbon cartridge.
- (c) Check that the printed circuit boards are properly seated in their connectors.
- (d) Check the cable connectors and fingerboards to insure they are firmly seated in their sockets.
- (e) Verify that paper tape is properly seated in Vertical Format Unit.

2.5 OPERATOR CONTROLS AND INDICATORS

2.5.1 Control Panel

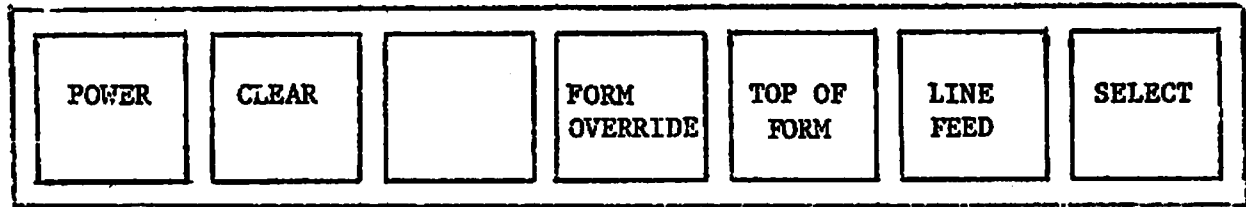

FIGURE 2-3 CONTROL PANEL

- POWER-ON LAMP:** Illuminates when power is on.
- SELECT SWITCH:** Enables input to the unit. The switch illuminates when the printer is selected.
- TOP OF FORM SWITCH:** Advances paper vertically to next top-of-form position; switch is disabled when unit is selected.
- LINE FEED SWITCH:** Advances paper vertically one line when held down momentarily. If held down continually, it will advance paper continually in one line segments. Switch is disabled when unit is selected.
- PAPER-OUT SWITCH:** (on chassis) Opens about one inch before paper runs completely out. At this time, the switch disables the input and turns on the audio alarm for approximately 1 second. The Form Override Lamp is illuminated.
- FORM OVERRIDE SWITCH:** Overrides the paper-out switch and allows completion of the final form. The lamp illuminates when the paper out switch opens.
- PAPER OUT LAMP:** May be cleared by refilling paper and depressing Forms Override Switch.

SERVO ALARM LAMP: Lights when servo fuse is open and servo logic is active.

2.5.2 Rear Panel (Figure 2-4)

ON/OFF SWITCH: Switches power on and off.

SERVO MOTOR FUSE: 2.5A SLO BLO Fuse - protects servomotor during paper jam conditions or logic failure.

MAIN FUSE: 2 amp (SB) 250 volt fuse for 115 VAC or 1 amp (SB) for 230 VAC.

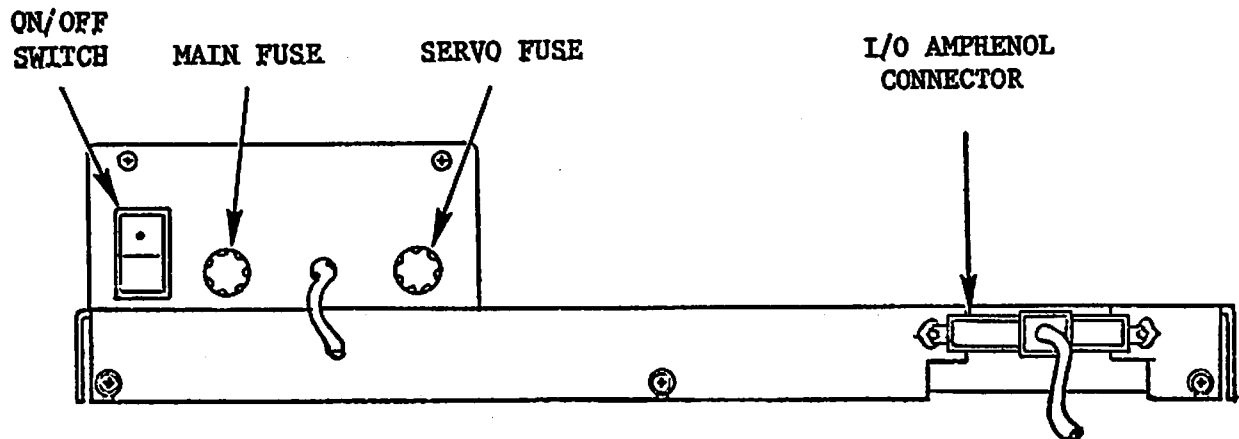

FIGURE 2-4 REAR PANEL

2.5.3 Printer Chassis

PLATEN KNOB: Advances the paper when manually depressed and turned. To vertically align forms, depress Top-of-Form Switch and then manually advance forms for proper alignment.

PAPER MARGIN KNOBS: Adjust sprockets to paper width.

HEAD ADJUSTMENT ARM: The head adjustment arm adjusts the distance between the printhead bearing and the striker bar. The arm is adjusted for the best print quality (position 1 to 9). To load a new ribbon cartridge, move the Head Adjustment Arm to position L.

2.6 DYNAMIC CHECKOUT

- 1) Connect power cord to 115 or 230 volt outlet as specified. Be sure that the unit has the proper input.
- 2) Connect I/O cable from I/O connector on rear of printer to controller in 2200 CPU or 2282 Graphic Terminal. Typical configurations shown in Fig. 2-5.

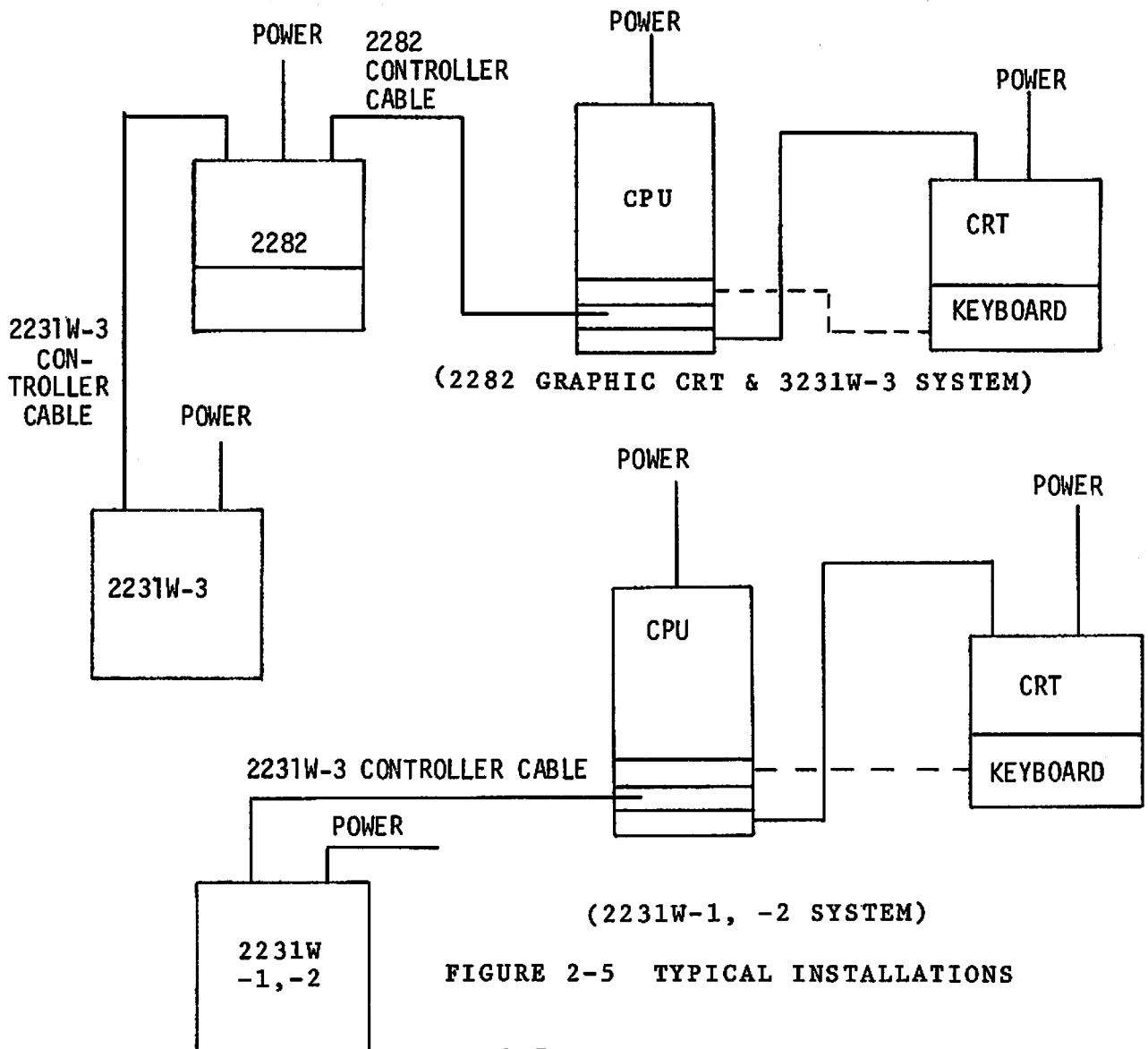

FIGURE 2-5 TYPICAL INSTALLATIONS

- 3) Load paper. NEVER OPERATE THE PRINTER WITHOUT PAPER.
 - (a) Place printer near and parallel to the front of table to allow insertion of paper into paper slot.
 - (b) Loosen paper margin knobs of pin feed sprockets and adjust to paper width.
 - (c) Slide paper into paper slot on the bottom or bottom front of the machine. Push it through until it reaches the pin feed sprockets. Fit the feed holes of the paper into the pin feed sprockets and close the paper guide covers.
- 4) Turn power on and be sure that the cooling fan is running.
- 5) Select the unit and run 2231W printer diagnostic.
See maintenance Section 6 for procedures.

SECTION 3 OPERATION

3.1 GENERAL

The controls and indicators are the same on all three models of the matrix printers. The controls are presented in Section 2, paragraph 2.5.

3.2 VERTICAL FORMAT UNIT

The Vertical Format Unit (VFU) is a two (2) channel tape reader, located on the left side of the printer, which reads a standard 1" wide, 8-channel black opaque paper or mylar tape. Because the operation of the tape reader is dependent on the switching of light via punched holes in the tape, the use of transparent tape could result in vertical format errors.

The VFU is linked directly to the stepping motor which advances the paper (by one line) and the paper tape (by one sprocket hole for each line feed). This linkage produces six (6) lines per inch. On the standard VFU paper tape shipped with the printer, vertical tab holes are spaced six sprocket holes apart, corresponding to a one inch tab (2.54 cm), and top of form holes spaced sixty-six (66) sprocket holes apart (corresponding to an eleven inch (27.9 cm) form.

If it is desired to use a shorter or longer form, then a new paper tape must be punched to change the vertical tab and top-of-form positions on the tape.

Each vertical tab function will advance the tape to the next hole on channel five of the paper tape.

Each top-of-form function will advance the tape to the next hole on channel seven of the paper tape.

A format tape may be punched using a Teletype^R. Figure 3-1 illustrates a typical tape and a chart with characters or functions of a Teletype which may be used to punch the selected holes. Format tapes will vary in length with paper form sizes.

TYPICAL FORMAT TAPE

<u>FUNCTION DESIRED</u>	<u>CHARACTER OR FUNCTION ON TELETYPE WHICH CORRESPONDS</u>
VERTICAL TAB	CONTROL P
TOP OF FORM	SHIFT P
SIMULTANEOUS VERTICAL TAB AND TOP OF FORM	P
SPACING BETWEEN FUNCTIONS	CONTROL SHIFT P

NOTE:

Holes punched anywhere other than channels 5 and 7 are ignored by the VFU.

To splice prepared format tape, cut a piece of 1" black opaque paper tape at least 15" long. (This length will provide two top-of-form functions.) Determine exactly where the tape is to be spliced by counting sprocket holes and vertical tab holes. Overlap the tape ends, mark the tape accurately, cut the surplus tape square across so the new ends butt evenly to the same sprocket hole. Trim as necessary and splice the ends using splicing squares WL# 660-0176 on both sides of tape to prevent catching and breaking of splice (see Figure 3-2).

To replace the Vertical Format Tape, lift the cover of the printer to gain access to the tape reader. Lift upper reader cover and install tape, be sure that the sprocket teeth protrude through the paper tape. Close reader cover.

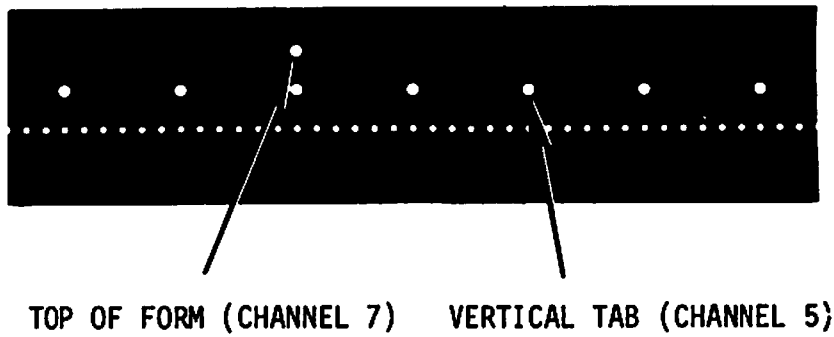

FIGURE 3-1 VERTICAL FORMAT TAPE

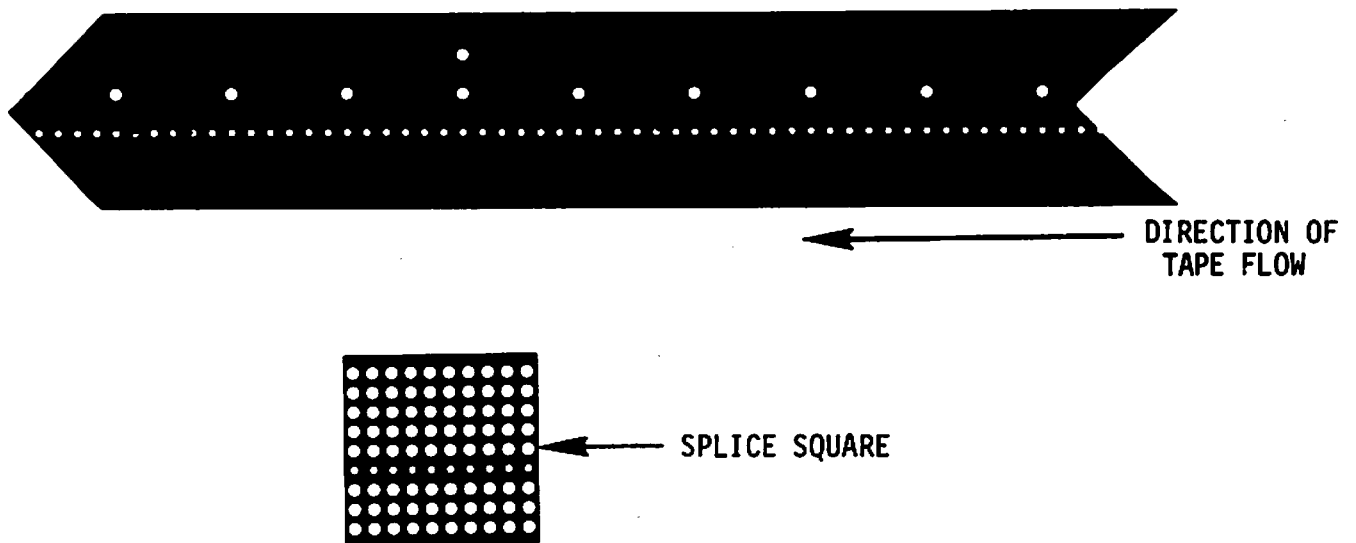

FIGURE 3-2 TAPE FLOW AND SPLICING SQUARE

NOTE:

It is important that the tape proceed through the tape reader in the up direction with the channel holes punched as shown in Figure 3-2. If the paper tape loop is inadvertently turned inside out, the paper feed will not work properly.

3.3 RIBBON CARTRIDGE REMOVAL AND REPLACEMENT

3.3.1 Removal

- 1) Lift open the printer cover.
- 2) Move Head Adjustment Arm to load L position (Figure 3-3).
- 3) Pull up vertically on the right side of the ribbon cartridge until it is completely off its spindle.
- 4) Remove the ribbon from print head ribbon guide and remove ribbon cartridge.

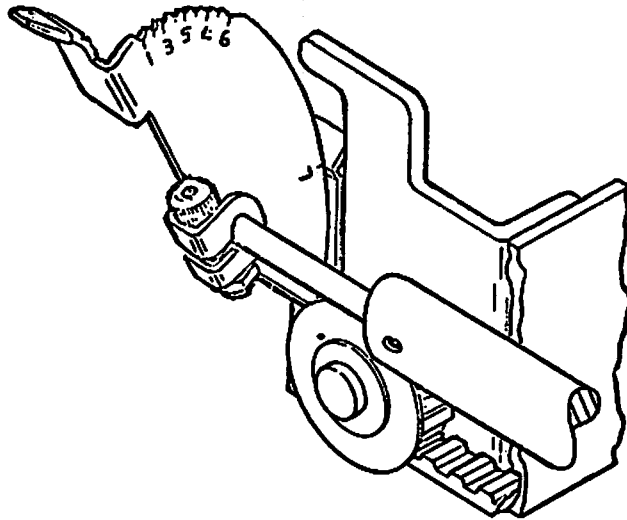

FIGURE 3-3 HEAD ADJUSTMENT ARM

3.3.2 Replacement

- 1) Move Head Adjustment Arm to load (L) position (Figure 3-3).
- 2) Turn Ribbon Advance Knob counterclockwise to take up slack in ribbon.
- 3) In this step it should not be necessary to handle the ribbon. Tilt the ribbon towards the bottom rear of the machine while sliding the ribbon into the ribbon guides on the print head. Tilt ribbon cartridge downward toward the rear of the machine so the lip at the left and right corners of the cartridge slip into the carriage guides. Push down on cartridge until carriage spring seats in cartridge indentation by the ribbon advance knob.
- 4) Turn Ribbon Advance Knob counterclockwise to take up slack in ribbon.
- 5) Move the Head Adjustment Arm back to its original position (1 to 9) and close the top cover.

3.4 OPERATION OF 2231W VIA 2200 CPU

NOTE:

Operation of all three versions of the 2231W is basically identical, the only differences involve line length and pitch. Therefore the 2231W-1 will be used as an example to demonstrate operation of the printer. Where differences in operation occur, they will be identified.

3.4.1 Device Address Codes

A three character device code, HEX XYY, is assigned to each peripheral that is connected to the 2200 CPU. The first character, X, is the device type and the next two characters, YY, are the device address.

There are three device types for the 2231W:

- 1) HEX X = 0: This device type addresses devices that do not index when a carriage return is executed; the 2200 automatically adds an index to the device. Since the 2231W generates an index with a carriage return, the output of the 2231W will be double space if a 0 is used.

- 2) HEX X = 2: This device type addresses devices that generate an index with a carriage return. The output of the 2231W will be single spaced if a 2 is used.

- 3) **HEX X = 4:** The **SELECT** statement specifies the maximum line length on the line printer. When the number of characters equals the specified line length, a carriage return is executed. Choosing device codes 415 or 416, however, suppresses this feature by not executing a carriage return when the number of characters equals the line length. The carriage return is not executed until the carriage return command is given or the buffer on the 2231W is filled. This gives a more interesting double spaced output when used to list program steps. Each individual statement longer than 112 characters will be single spaced, while the space between statements will be double spaced. Samples of printouts can be seen in diagnostic Section 6.

- 4) There are two device address codes for the 2231W:
 - a) **HEX YY = 15:** This is the address normally used when one printer is connected into a system. If two printers are connected in a system, code 15 addresses the first printer.

 - b) **HEX YY = 16:** This addresses the second printer connected to a 2200 system.

3.4.2 Select Statements

There are three select statements which select the 2231W for distinct types of output: **SELECT PRINT**; **SELECT LIST**; and **SELECT CO**.

(a) **SELECT PRINT 215**

The above statement selects the 2231W with the device address code 215 for output resulting from the execution of **PRINT** or **PRINTUSING** statements.

EXAMPLE:

Be sure that all units are on and the 2231W selected.
Key the following program:

```
CLEAR
10 SELECT PRINT 215
20 PRINT "X", "LOG X"
30 FOR X = 1 TO 10
40 PRINT X, LOG (X)
50 NEXT X
RUN
```

PRINTOUT:

X	LOG X
1	0
2	.6931471805597
3	1.098612288667
4	1.386294361119
5	1.609437912433
6	1.791759469227
7	1.945910149055
8	2.079441541679
9	2.197224577335
10	2.302585092994

If statement 10 was SELECT PRINT 015, the output would be double spaced.

(b) SELECT LIST 215

The above statement selects the 2231W with the device address code 215 for all program listings.

EXAMPLE:

To list the preceding program, key the following:

```
SELECT LIST 215
LIST
EXECUTE
```

PRINTOUT:

```
10 SELECT PRINT 215
20 PRINT "X", "LOG X"
30 FOR X = 1 TO 10
40 PRINT X, LOG(X)
50 NEXT X
```

(c) SELECT CO 215

The above statement selects the 2231W with the device address code for printing all console output. All information keyed into the 2200 system will be printed on the 2231W until any other console output device is selected.

EXAMPLE:

Key the following:

```
SELECT CO 215
EXECUTE
RESET
```

PRINTOUT

READY

Assuming the CRT was being used, it is now de-selected and the 2231W outputs all information. The printer prints a line anytime the RETURN key is depressed or as soon as the previously set line length is exceeded (see Section 3.4.3). To de-select the 2231W and select the CRT, key the following:

```
SELECT CO 005
EXECUTE
```

The CRT is now the selected device. To list the program on the CRT, enter:

```
SELECT LIST 005
```

3.4.3 Line Length

- (a) The 2231W-1 has a maximum of 112 characters per line while the 31W-2 prints 119 characters per line and the 31W-3 prints 132. When turning system power on, the line length on all devices is set for 64 characters (because of CRT line length). To make use of the full line of characters the printer must be commanded in its address statement:

```
SELECT PRINT 215 (112) FOR 2221W-1
SELECT PRINT 215 (119) FOR 2221W-2
SELECT PRINT 215 (132) FOR 2221W-3
```

The number in parenthesis indicates that the specified number of characters will be allowed to be printed before an automatic carriage return is given.

- (b) Any amount of characters may limit the line length:

```
SELECT PRINT 215 (25)
```

The 25 in parenthesis only allows 25 characters to be printed on a line; an automatic carriage return would be generated if this number of characters is exceeded. The remaining characters would be printed on the next line(s).

NOTE:

If a line limit of 25 characters is given for the 2231W, this limitation applies to any output device that is selected after the 2231W if no new limitation is specified.

- (c) More than one line length may be combined in a select statement.

EXAMPLE:

```
SELECT PRINT 215 (25), LIST 215 (64), CO 215 (112)
```

3.4.4 Tab Function

When a print statement containing a TAB() expression is encountered, the printer will advance to the column indicated in parenthesis in the TAB() expression.

EXAMPLE:

```
10 SELECT PRINT 215 (112)
20 PRINT TAB (25); "WANG LABS"
30 STOP
RUN
```

When these statements are executed, the 2231W advances to column 25 and prints "WANG LABS".

NOTE:

If a semicolon (;) is not used after the TAB() function, the 2231W will not necessarily tab to the correct column.

3.4.5 Expand Function: HEX (OE)

The regular characters, (10, 12, or 14.4/ horizontal inch), can be expanded to double their width, (5, 6, or 7.2/ horizontal inch), with the following statement:

```
PRINT HEX (OE), "WANG LABS"
```

The expand function only expands one line of print. Assuming a line limit of 112 characters in the 2231W-1, when more than 56 characters are to be printed with the expand function, only the first 56 are printed, the 2231W performs a carriage return and all other characters are lost. If a line limit of less than 56 characters is selected, and the number of expanded characters exceeds the selected line length, the expanded characters are printed up to the line limit, the printer carriage returns and prints the remaining characters on the next line (s) in regular size.

EXAMPLE:

```
10 SELECT PRINT 215 (5)
20 PRINT HEX (OE), "1112223333444"
30 STOP
```

PRINTOUT:

```
1 1 1 2 2
2 3 3 3 4
4 4
```

A line limit of 5 was given to the printer; the printer was instructed to expand the twelve numbers. The printout illustrates that:

- 1) The printer only printed five elongated characters on the first line.
- 2) When the characters are expanded, so are the columns.
- 3) The excess characters were printed on the next two lines, the second line containing only five characters and the third line the rest.

Not only does the expand function expand the characters and columns, but also the zones.

3.4.6 Zones

The 2231W-1 is divided into seven zones of 16 characters each. The zones constitute columns 0-15, 16-31, 32-47, 48-63, 64-79, 80-95, and 96-111 respectively. The 2231W-2 and -3 have similar zones corresponding to their line lengths.

If commas separate elements in a PRINT statement, then each element begins at the start of a new zone. If semicolons separate elements in a PRINT statement, the zoned format is ignored, and the output appears in packed format.

3.4.7 HEX Function

The HEX function is used in a BASIC program to output characters on the printer that do not appear on the standard keyboards or to output special printer control codes. The HEX function has the form:

HEX ([hh] [hh]...)

where h = a hex digit 0 to 9 or a letter A to F. An even number of characters must always appear in a HEX statement; spaces are not allowed. (See the Wang BASIC Reference Manual for hexadecimal characters and codes.) HEX codes can be combined.

EXAMPLE:

```
10 SELECT PRINT 215
20 PRINT HEX (2424)
30 END
```

PRINTOUT:

\$ \$

3.4.8 Control Codes

The special Control Codes for the printer are:

<u>FUNCTION</u>	<u>HEX CODE</u>	<u>DESCRIPTION</u>
ALARM	HEX (07)	Generates an audible tone about one second in duration in the speaker at the rear of the printer.
LINE FEED	HEX (0A)	Advances paper one line.
VERTICAL TAB	HEX (0B)	Advances paper until the next hole in channel 5 of the Vertical Format Unit paper tape is reached.
FORM FEED	HEX (0C)	Advances paper until the next hole in channel 7 of the Vertical Format Unit paper tape is reached.
CARRIAGE RETURN	HEX (0D)	Causes the line of characters stored in the printer buffer to be printed. An automatic line feed occurs after the line has been printed and the print head returns to the left side of the printer.
ELONGATED	HEX (0E)	Prints a full line of expanded (double width) characters.
DELETE	HEX (7F)	Clears buffer of partial line prior to the '7F'.

2231W-3 CONTROL CODES

<u>FUNCTION</u>	<u>HEX CODE</u>	<u>DESCRIPTION</u>
SET PLOT MODE	HEX (08)	Places the printer in the Plot mode. In this mode the printer accepts input from the Model 2282 Graphic CRT.
SET LINE FEED SPACING	HEX (09XX)	Sets the line Feed spacing as HEX (XX) times 1/72 inches. XX can vary from 01 to 0F (1 to 15). The default value for line feed spacing is 15 set by the switches on the 6795 PCB. Sending a HEX (09XX) code to the printer sets the line feed spacing to HEX(XX) times (1/72) for a single print line. Subsequent lines are printed at the default spacing equal to the switching setting on the 6795 PCB.
COPY GRAPHIC CRT	HEX (E7)	This code causes the CRT image to be reproduced on the 2231W-3 printer. The line spacing on the printer is automatically selected to produce a copy of optimum accuracy.
SELECT PRINTER	HEX (E9)	This command will select the printer for output, and all non-special characters received after this will be ignored by the CRT and be sent to the printer.

NOTE:

When HEX codes are combined, control codes are executed first.

See Appendix A for complete listing of hexadecimal codes.

3.4.9 2231W-3 Operation with 2282 Graphic CRT

When used with the 2282, the HEX code E7 when encountered in a program will print the contents of the CRT screen, one line at a time.

HEX (E7) puts the printer in the plotting mode and presets all variables for correct printing of the graphic display.

SECTION 4
THEORY OF OPERATION

4.1 INTRODUCTION

This section of the manual consists of three basic parts: a mechanical section including a general description of carriage movement and paper movement; an electrical section that includes a general description of logic and an electrical section with a detailed logic description of the printed circuit boards. Signal Mnemonics are presented in Appendix B.

4.2 GENERAL

The 2231W Printer consists of the following electronic basic blocks (Figure 4-1):

Input Buffer - Buffers input data to function decoder and shift registers

Storage Shift Registers - 2-quad 80 bit and 2-quad 32 bit shift registers are used in series to store up to 112 input characters.

Function Decoder - Monitors input data for function commands and transmits function to be performed to the control logic.

Character Generator - Converts 7-bit ASCII character codes to the dot-matrix pattern used to drive the print solenoids.

Driver Circuits - Power transistors, clamping diodes, etc. Used as output drivers for the print solenoids and motors.

Carriage Servo - Circuit used to control speed and direction of the carriage motor. Feedback generated by pulses from timing wheel and magnetic reluctance pickup provide the error correction voltage.

Stepping Motor Control - Provides START/STOP logic for serial pulse train generator. A state generator (circular shift register) provides the proper pattern to the phases of the stepping motor.

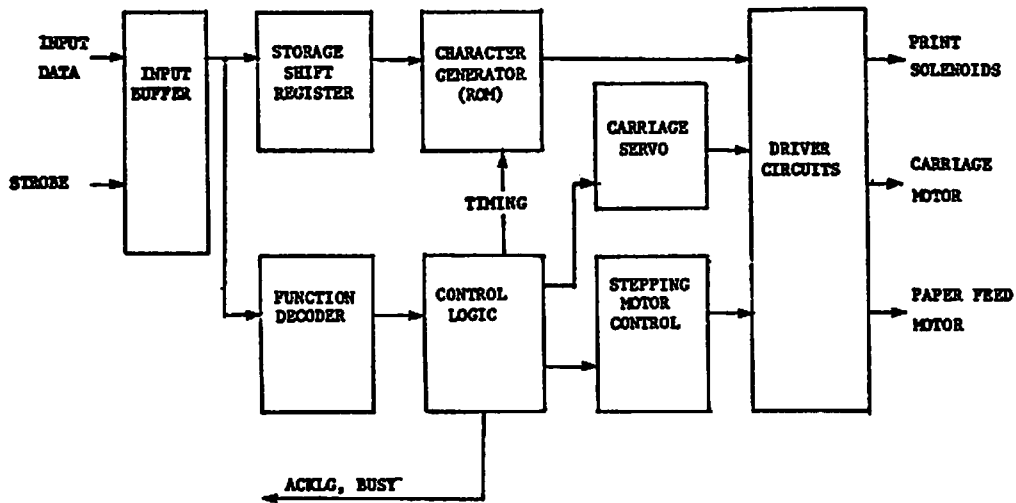

FIGURE 4-1 MODEL 61 BASIC BLOCK DIAGRAM

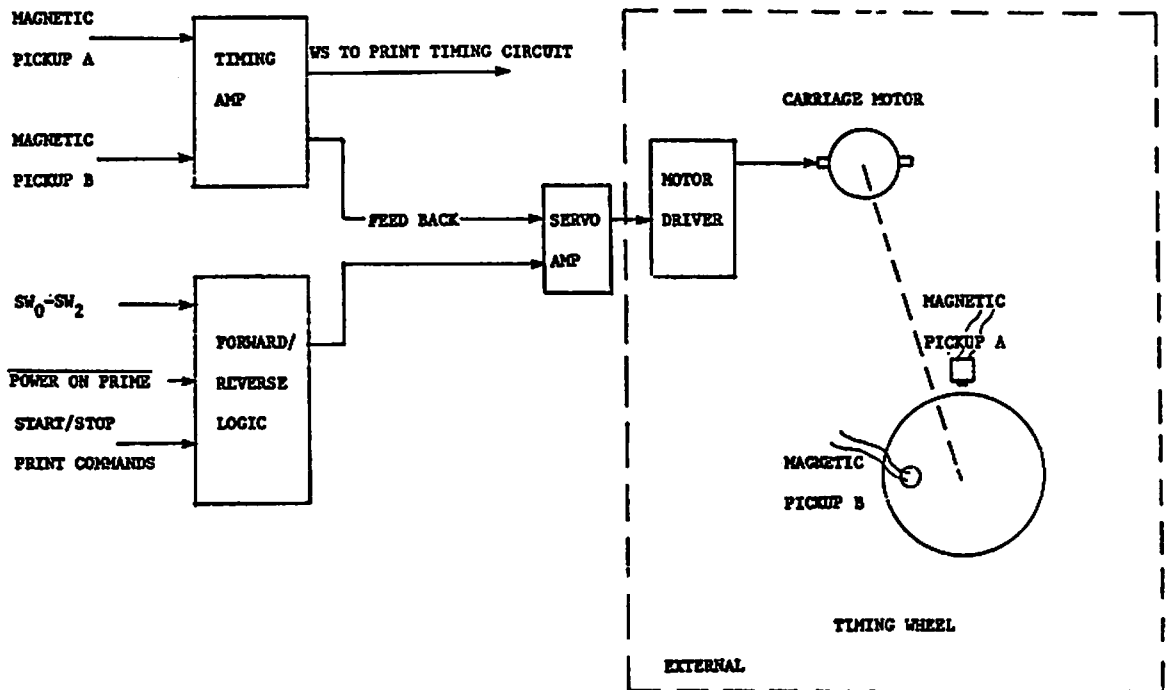

FIGURE 4-2 CARRIAGE MOVEMENT

Control Logic - Consists of the following: main clock, power-up prime, busy, and shift circuits and control for all operations.

4.3 GENERAL OPERATION

The following discussions are primarily keyed to the 2231W-1 printer. The other models follow very closely. Consequently, only one Theory-of-Operation is needed to understand the operation of all three models. However, a brief 2231W-3 theory is presented at the end of this section to identify the few major differences.

4.3.1 Carriage Movement and Print Timing

A carriage assembly (See Figure 1-1) moves the print head across the paper. Printing is performed by selectively firing the print head solenoids as the assembly moves from left to right. Synchronization of the print process and carriage movement is provided by two magnetic reluctance pickups and a timing disk (See Figure 4-2). The disk on the 31W-1 is made from a ferrous metal, has 780 teeth around its circumference, and one hole drilled through its flat surface. The 31W-2 and -3 have a similar disk with more teeth to correspond to 10; 12, or 14.4 pitch characters.

A magnetic reluctance pickup, located near and perpendicular to the circumference of the disk, senses flux changes as the disk's teeth rotate by. These flux changes create a small voltage pulse in the pickup which is amplified and shaped by the timing amplifier. This signal is used to generate a reference strobe (\overline{WS} , window strobe) for print timing, and negative feedback to the servomotor amplifier which controls the carriage motor. The Forward/Reverse logic blocks control the speed and direction of the motor.

Another magnetic reluctance pickup, located so the hole in the disk passes over it each rotation, generates an index pulse which determines the left-hand margin when printing.

There are three (four for the 2231W-3) reed switches (SW_0 - SW_2) located on the frame under the carriage block. These switches are activated by a magnet located on the underside of the moving carriage. The outputs of the switches and Start/Stop logic are used to control forward and reverse logic for the servomotor.

4.3.2 Servomotor Logic

The timing disk and magnetic reluctance pickups are used to generate print timing and feedback for the servo system. The timing disk is mounted to the rear shaft of the carriage servomotor. As the servomotor and disk turn, magnetic reluctance pickups MPA and MPB sense flux changes and generate pulses which are amplified and applied to a logic network to develop timing and feedback signals.

Magnetic reluctance pickup, MPA, is mounted near and perpendicular to the circumference of the timing disk. As each tooth passes the pickup, the flux changes cause a small signal to be generated with a frequency which is a function of the motor speed. After amplification, the signal's leading and trailing edges are used to trigger four one-shots. Two of these one-shots generate 550 us pulses which are ORed and applied to the \overline{WS} gate. \overline{WS} is used to generate print timing. The other two one-shots generate pulses which are applied to a summing network to provide the servo op-amps with a DC bias that varies directly with the motor speed.

The second magnetic reluctance pickup, MPB, is located perpendicular to the flat surface of the timing disk. This pickup senses the passing of the hole drilled in the disk. The signal generated by the passing hole is used to set a flip-flop to gate \overline{WS} and insure a consistent left margin.

4.3.3 Paper Movement (Figure 4-3)

Paper movement is produced by three separate functions: line feed, vertical tab and form feed. Each of these functions activates the stepping motor causing paper movement. Vertical tab and form feed will step the motor until a hole in the appropriate channel of the vertical-format paper tape is detected by the tape reader.

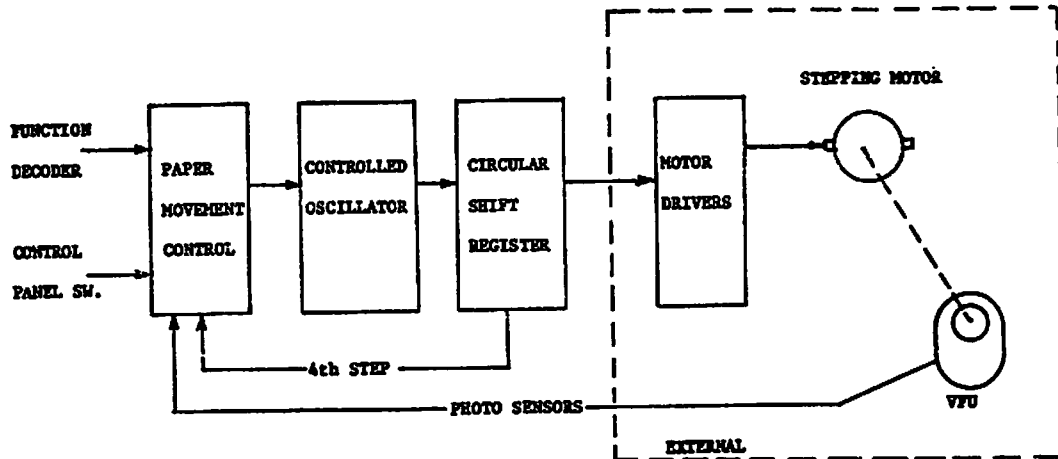

FIGURE 4-3

The Vertical Format Unit (VFU) is an optical tape reader which only reads 2 channels (5 and 7). VFU tape movement is caused by direct mechanical linkage to the paper-feed gear train. See Operation Section (3) for more details.

LINE FEED - (Moves paper vertically one line at time per LF function). Line feed can be generated by any of the following three conditions:

- (a) Automatic line feed during each carriage return.
- (b) Receiving a line-feed code HEX (0A) via the input as decoded by the function decoder.
- (c) Depressing the line feed key on the control panel of the 2231W. (In this case, the printer must be de-selected.)

VERTICAL TAB - Vertical tab can be generated only by receiving a vertical tab code HEX (OB). (Moves paper vertically 1" at a time as standard set up.)

FORM FEED - Form feed can be generated by:

- (a) Receiving a form-feed code, HEX (OC), at the input decoded by the function decoder (paper moves vertically to the top of the next form).
- (b) Pressing the Top-of-Form key on the control panel (printer must be deselected).

4.3.4 Paper Feed Logic (Refer to drawing E6761 for 31W-1 and 2, 6794 for 31W-3)

A stepping motor, mounted in the rear on the left-hand side of the Printer (See Figure 1-1) is used to drive the paper feed mechanism and the Vertical Format Unit (VFU). Each step of the motor accomplishes a 15° rotation; there are 4 steps for each line feed. The motor utilizes a two-phase drive provided by a J-K flip-flop. A Phase State Generator is clocked by a resettable astable oscillator called the Paper Feed Oscillator.

All conditions causing paper movement such as $\overline{\text{LFM}}$ (Line Feed Manual), $\overline{\text{LFP}}$ (Line Feed Pulse), etc., set the paper feed flip-flop high enabling the oscillator and the state generator. With the paper feed flip-flop set, LF will be high inhibiting the print gate, and therefore printing, during paper-feed functions.

The paper feed flip-flop L9 and L15 can be set by applying a low on any of the inputs of the expandable NAND gate. These inputs are:

- (a) $\overline{\text{LFP}}$ from the function decoder.
- (b) $\overline{\text{LFCR}}$ generated by carriage return as a first character.

- (c) Return gate output from the 2nd carriage return decoder, and by the right limit switch $\overline{SW2}$ located under the carriage run.
- (d) \overline{LFM} from the key on the control panel gated with \overline{SL} (Selected Status) and the Line-Feed Delay one-shot.
- (e) A Form-feed flip-flop.
- (f) A Vertical-tab flip-flop.

The Form-Feed Flip-Flop is reset by \overline{POP} on power up or by a 4th step gate. If either the Form-Feed Flip-Flop or Vertical Tab Flip-Flop/remain set, the paper feed flip-flop cannot be reset.

The Form-Feed Flip-Flop can be set by either \overline{FFP} (Form-Feed Pulse) from the Function Decoder or the Form-Feed Manual Switch (\overline{FFM}) on the Control Panel.

When a hole is detected in channel 7 of the VFU tape, the Form-Feed Flip-Flop is reset by FFS (Form-Feed Photo-Transistor Emitter) in the VFU Assy.

The Vertical-Tab Flip-Flop is set by pulse \overline{VTP} from a function decoder and is reset when a hole is detected in the VFU tape, (channel 5).

4.3.5 Print Operation (Figure 4-4)

All print timing is derived from the \overline{WS} (MPA and MPB) signals and a master clock. As shown in the block diagram, the clock generator subscripts represent its sequence with respect to \overline{WS} strobe. The character storage bits b_1 to b_7 from the character shift register are presented to ROMs as addressing bits. A column counter is used to address each column of the character matrix and is incremented by CLK_4 the clock generator for each \overline{WS} . At a count of nine, $\overline{SF6}$ is sent to the character storage to shift out the next character. On the tenth count, the counter is reset to zero.

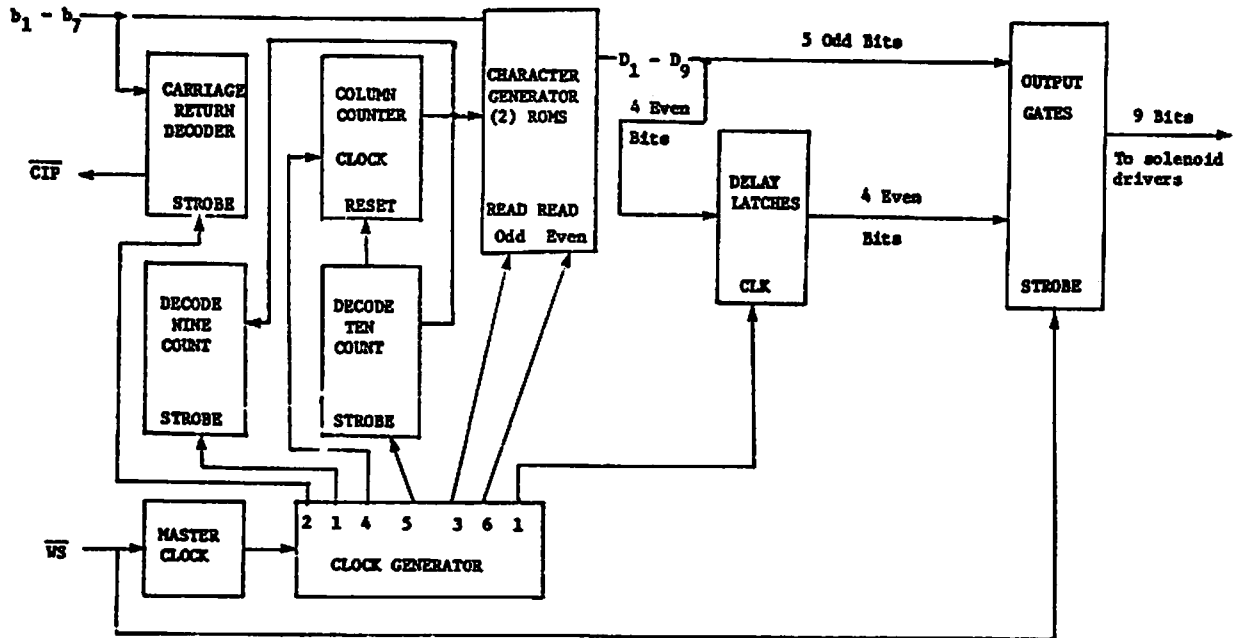

FIGURE 4-4

The carriage return code from data input is decoded to indicate end-of-line; \overline{CIP} (Control Input Prime) is generated to prime the control logic and originate a carriage return.

Due to mechanical consideration, the nine print solenoid wires are not in one vertical column. The five odd solenoid wires precede the four even wires as the print head moves across the carriage. Delay latches are used to delay the outputs to the even solenoids. The delay allows the print head to move in line with the dots printed by the odd print wires before printing with the even solenoids. This results in a vertical line of printed dots.

4.3.6 I/O Control and Character Storage (Figure 4-5)

The printer accepts a 7-bit ASCII code. A data strobe is necessary to accept and process the data. Data bits D_1 to D_7 are true for a logical "1" (high). \overline{DSTB} must be a low pulse with a duration of .5 us to 5 us.

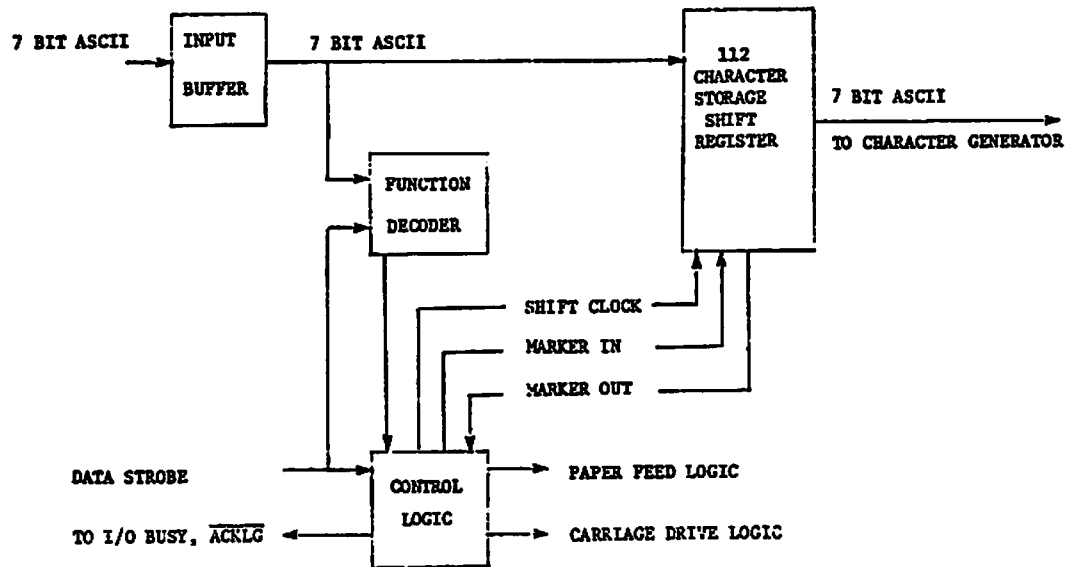

FIGURE 4-5

The input data is buffered to the storage shift registers and the function decoder circuits. When a function is decoded, the control logic activates the appropriate circuits to perform the function. A BUSY status is provided at the I/O interface to indicate that the printer is busy. When the printer is again ready, an acknowledge pulse ($\overline{\text{ACKLG}}$) is sent to the I/O connector.

A control logic shift-gate generates the shift clocks necessary to shift data in and out of the storage registers, and the marker bit initiated by DT8 is used to indicate a buffer full condition. Upon detecting a carriage return code or a buffer full condition, the control logic initiates the print cycle. During the print cycle the carriage moves forward and the characters are shifted from the shift register to the character generator ROMs and print solenoids with appropriate delay of even solenoids. When the print cycle is completed, the control logic initializes the printer circuits for a new line of input.

4.4 DETAILED THEORY OF OPERATION

During the detailed discussions of this section continual reference will be made to the appropriate engineering schematics. To quickly locate the circuits being discussed, reference will be made to the schematic grid system as follows: (G,11). Signals names are given in Appendix B.

The stars on the schematics indicate test points. Octagons indicate electrical adjustments, and rectangles give the units' functional name of a given stage of logic.

4.4.1 Timing and Printing Control (Refer to drawing E6761 and E7060 Schematics)

4.4.1.1 Carriage Movement Detailed

When power is applied to the printer, $\overline{\text{POP}}$ on the 7060 board (L10) (H,11) is generated and initializes the carriage-drive and paper-feed control logic on the 6761 PCB. If the carriage is not at home position (SWO closed), a carriage return will be performed.

$\overline{\text{PRINT}}$ from the 7060 board (G,5) starts the carriage moving by setting the forward and run flip-flops (6761) (G,11) with $\overline{\text{SFM}}$. $\overline{\text{CF}}$ and $\overline{\text{RN}}$ enable the forward gate L30-8 (G,8) which closes the forward relay. This action puts a positive voltage on the output of M0 which feeds the motor drivers on PCB 6756 (F,7).

A ferrous timing disk attached to the motor shaft has a toothed edge which passes a magnetic pickup and generates a voltage. This signal voltage is amplified and shaped to a rectangular pulse whose frequency is a function of the motor speed. The leading and trailing edges of this pulse are used to trigger the feedback one-shots, L28-9 and L28-7 (G,10). Note that the feedback control gate L6-6 (G,11) is held high by $\overline{\text{CF}}$, releasing the clear lines of the one-shots. The outputs of the feedback one-shots are applied to an integrating

circuit causing the input of the carriage motor amplifier L27 (G,7)(6756) to be less negative. Since the amplifier is an inverting configuration, the output MO (output servo motor amplifier) will be less positive as the feedback increases. This serves to maintain a constant forward speed of the carriage assembly. Potentiometer R71 (6761)(G,8) is used to adjust the speed of the carriage motor by changing the negative bias of the amplifier input.

Carriage return will be initiated by the limit switch $\overline{SW2}$ (6761)(I,8) (closed) or by a carriage return code sensed at the output of the shift registers (7060)(L8-9, L8-11)(b6,b7)(J,7). Either one will cause the forward flip-flop to be reset via the return gate L32-4 (6761)(G,12). \overline{CIP} (H,9) is generated at this time to perform a prime routine. \overline{CF} goes high disabling the forward gate L30-8 (G,8) and \overline{CF} goes low to enable the reverse gate L30-6. The reverse relay closes switching the second-stage of the servo amplifier to the input of the motor amplifier shown in schematic 6756 (G,7). MO will now be negative causing the carriage to return.

If the line printed was of sufficient length to cause the carriage to move past $\overline{SW1}$, then the fast/slow decision flip-flop L6-3 (6761)(F,11) will be set high. The feedback control gate L6-6 (G,11) will go low disabling the feedback one-shots L28 (F,10). With no feedback, a fast return is performed. On the fast return, the carriage magnet again closes $\overline{SW1}$ and resets the fast/slow decision flip-flop L6. The feedback control gate L6-6 goes high releasing the one-shots L28 clear line. Feedback is generated to decelerate the carriage before it reaches full left. When the carriage reaches $\overline{SW0}$, the run flip-flop L13(F,11) will be reset and \overline{RN} will go high to disable both forward and reverse gates L30. Both relays K_1 and K_2 are now open and the motor stops. If the line to be printed is so short that the carriage does not pass $\overline{SW1}$, then the fast/slow decision flip-flop will not set and only a slow return will be performed.

As the carriage moves, the signal from the magnetic pickup MPA, is amplified and shaped. As stated previously, it is used to trigger the feedback one-shots. It is also applied to another pair of one shots, L19-7 and L19-9 (J,11) whose outputs are negative ORed by \overline{WS} gate L3-3 (K,10). Potentiometer R10 adjusts the duty cycle of the input signal by varying the DC bias on the Q5. See Figure 4-6 for adjustment effect of R10 on the duty cycle of L19 one shots or window-strobe, \overline{WS} .

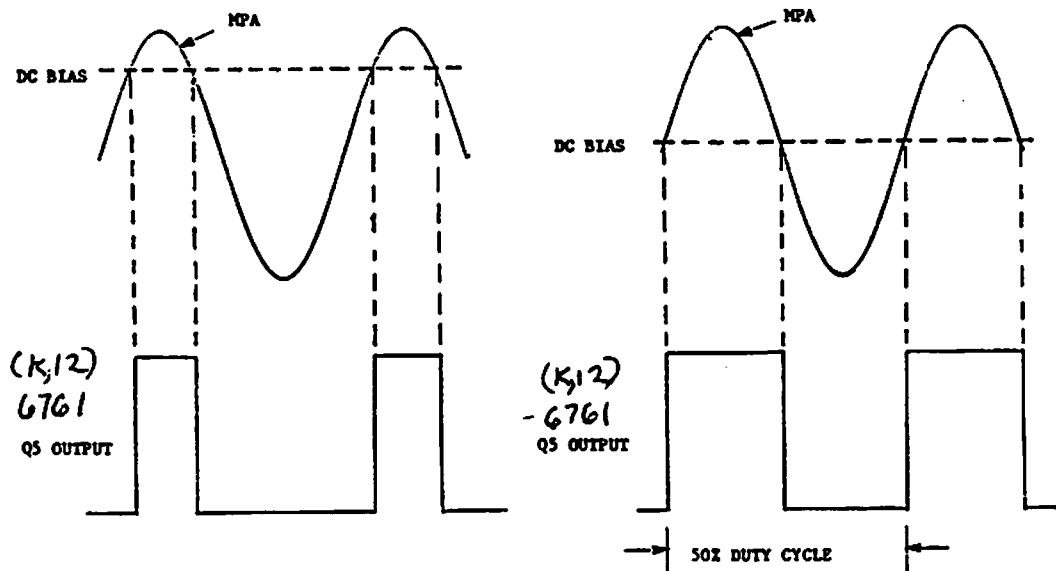

FIGURE 4-6 WINDOW STROBE (WS) ADJUSTMENT

There is also a magnetic pickup MPB, located near the index hole on the timing disk. The signal developed by this magnetic pickup is amplified, shaped and used to generate a uniform left margin. This pulse is gated with a delayed L19-9 (J,10) pulse to set the index flip-flop. $\overline{FS0}$ gate L10-6 (J,8) is enabled when the index flip-flop is set and \overline{CF} is high. The \overline{WS} strobe is now used to synchronize print timing with the master clock L2, through L4 flip flop and L3-6 gate to the clock generator L37. Timing relationships are shown in Figure 4-7. See paragraph 4.4.1.3 for more details.

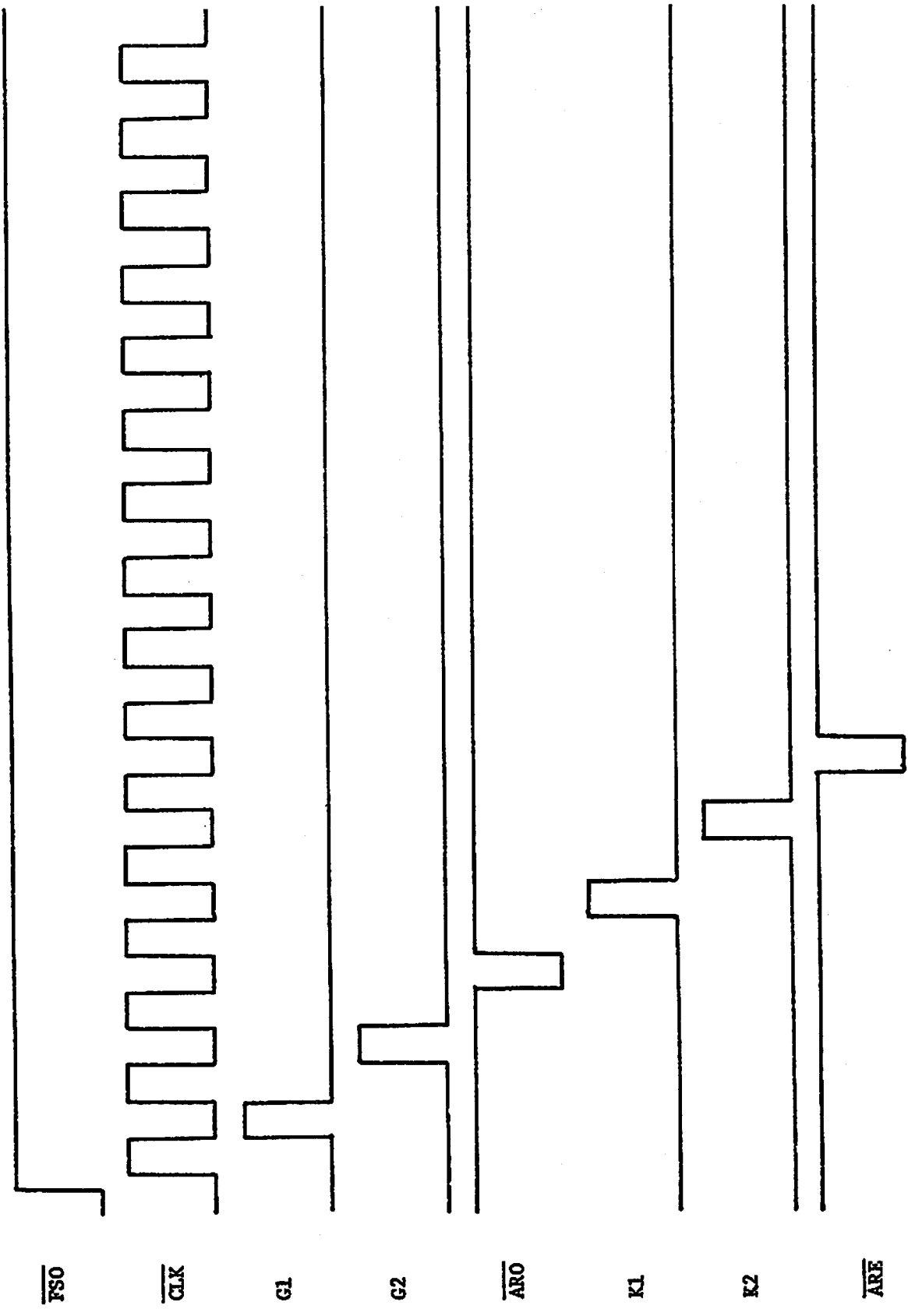

FIGURE 4-7 PRINT TIMING DIAGRAM

4.4.2.2 Paper Movement (Refer to drawing E6761)

A stepping motor is used to drive the paper-feed mechanism and the Vertical Format Unit (VFU). Each step of the motor accomplishes 15° rotation and there are 4 steps for each line feed. The motor utilizes a two-phase drive provided by L14 J-K flip-flop (D,8). This circuit is also referred to as the state generator.

L8 (E,10) the Paper-Feed Oscillator is a resettable, astable oscillator whose output is used to clock the state generator. For each cycle of L8, a step of 15° is performed. All conditions causing paper movement such as $\overline{\text{LFM}}$, $\overline{\text{LFP}}$ etc., set the paper-feed flip-flop L9-6 (D,11) high. This high releases the clear inputs of the state generator and the reset line of the L8 paper-feed oscillator.

The circuit of L14 (D,8) develops four combinations for stepping the paper-movement stepping-motor 15 degrees for each combination. The fourth step gate L15-8 (C,11) provides a negative pulse, following the fourth step, to reset the paper-feed flip-flop. This action clears the state generator and disables the oscillator.

The paper-feed flip-flop has an expandable NAND gate and provides six ways to perform paper movement. When a printed line is terminated by a carriage-return code or by the right limit switch ($\overline{\text{SW2}}$), the return gate L32-4 (G,14) sets the paper-feed flip-flop via L9-2 (D,11). $\overline{\text{LFP}}$ from the CPU data-input-function decoder 7060 (L33-3) (I,8) is applied to Paper-Feed F/F L9-1 via terminal 11-3 of 6761.

$\overline{\text{LFCR}}$ 7060 (L2-3)(F,6) is a signal generated when a carriage return-code is received as a first character via CPU input and L33-6(I,8) sets the paper-feed flip-flop via L9-5 6761 (D,11). $\overline{\text{LFM}}$ (B,14)(6761) from the operator panel line-feed control is NANDed with $\overline{\text{SL}}$ [from L21 Select FF (F,12) 7070] and LFD (L7-7)(B,11/6761) one-shot and provides an input to the expanded input L9-3 6761 (D,11). The expanded input is also activated by the outputs of the form-feed and vertical tab flip-flops [L16(C,14) and L16(B,14)] on 6761 schematic.

The form-feed flip-flop (C,12) can be set by $\overline{\text{FFM}}$ from the operator's panel or by $\overline{\text{FFP}}$ of the function decoder 7060(L33-5)(I,8). While the form-feed flip-flop is set, it will keep the paper-feed flip-flop 6761(L9)(D,11) from resetting. This is also true of the vertical-tab flip-flop, which is set only by $\overline{\text{VTP}}$ from the input function decoder as well. The form-feed and vertical-tab flip-flops are reset by FFS and VTS respectively from the photo transistor emitter in the Vertical Format Unit. FFS (Channel 7) and VTS (Channel 5), outputs from the phototransistors of the VFU, are amplified, shaped and gated with the fourth step pulse to reset the corresponding flip-flops. The paper movement flip-flops are also reset at power-up by $\overline{\text{POP}}$ from the output of L10-7 (7060)(H,11) which is triggered initially by the output of R55 and C12 RC circuit (7060)(G,10) at unit turn-on.

It should also be noted that the manual functions $\overline{\text{FFM}}$, $\overline{\text{LFM}}$, and $\overline{\text{CLEAR}}$ from the operator's panel are gated with $\overline{\text{SL}}$ such that they will be active only when the printer is deselected (Clear at H,8 on 6761 schematic, goes through L39 and L32 to paper feed F/F). Each of the outputs of the state generator X0 and Y0 L14 (D,8) are amplified by op-amps (E,10)(E,9) on the 6756 and applied to a complementary driver circuit. This circuit acts as a level translator to convert the logic levels of the state generator to levels of +17V or -17V for the motor windings.

4.4.1.3 Print Operation

The dot patterns for all the characters are contained in 2 ROMs. One ROM contains the odd-column dot pattern of the matrix for each character while the other ROM contains the even column patterns. By alternately selecting and reading each ROM, the full 8w x 9h dot matrix may be printed. (the printer matrix size is referred to as a 7w x 9h, however, a few characters are actually 8w x 9h.)

As the carriage starts moving, a signal is generated by the magnetic pickup MPA, and its associated amplifier. As the second magnetic pickup, MPB, senses the index hole, the index flip-flop is set and gates the signal from the $\overline{\text{WS}}$ gate to the clock network. Thus synchronization is maintained between printing and carriage movement.

On each edge of FSO at L3-6 (J,6) (Refer to E6761 and timing diagram Figure 4-7) the master clock is gated to the timing counter L36 (J,6). The timing counter output is decoded by L37 clock generator (J,6) to generate sequential timing for print operations.

On power-up and at the end of each line printed, the prime circuit produces a clear pulse CLR. It is used to reset the divide by 2 flip-flop, L4-12 6761 (G,6) and the column counter L5 (H,5).

G1 time strobes the SF6 gate L12-8 (I,4) which decodes a nine count and the G1 also strobes the delay latch L29 (K,3) on the 7060 board. G2 strobes the CR decoder L39-6 (G,13) on the 6761 board to insure that the character being printed is completed before reversing the carriage. G2 also strobes the delay latch L30 on the 7060 board.

On the 7060 board, ARO is the read strobe for the Odd ROM L14 (K,5) and ARE is the read strobe for Even ROM L15(J,3). Note that although ARO and ARE are both generated each cycle, they will have no effect unless the corresponding chip select SCO or SCE is active from the 6761 board.

On the 6761 board, K1 time is used to increment the column counter and K2 strobes the decoder, L22-8 (H,6) used to reset the counter.

FSE gate, L39-8 (H,4) is a quad input NOR w/strobe. The strobe is derived from an inverted FSO signal. FSE is active for only the even counts of the column counter except zero. At counts of zero and one, the expand divide by 2 flip-flop will not be set thus keeping FSE high. This action is necessary to keep the even solenoids from firing until the delay latches have been conditioned. On power-up, the delay latches, L29 and L30, of the 7060 contain undetermined information.

A₁ and A₂, the 2-bit and 4-bit outputs of the column counter address the ROMs. These two address bits select 4 locations in each of the two ROMs for a total possible 8 column by 9 row matrix.

During expanded print operation, \overline{EC} (H,4) (7060) will be low, causing column counter output, QA to be divided by two before being gated to the BIN input of the column counter. The effect is that each column of a normal size character is printed twice resulting in a symmetrical expanded character.

The ROM outputs (7060) are ORed through L4 (K,4) and L23 (K,4) which act as level translators. The outputs for the odd-numbered solenoids are gated by \overline{FSO} directly to the solenoid drivers. The even numbered outputs are applied to the delay latch L29 (K,3) at G1 time and at G2 time, are loaded into delay latch L30 (K,3). L30 outputs are gated with \overline{FSE} to the even solenoid drivers. The print head is physically constructed so that the odd numbered solenoids actually lead the even ones. Thus the delay latches provide the necessary delay to the even solenoids as the even dots are aligned with the odd dots for a straight vertical line.

The solenoid drivers on the 6756 board act as sink elements for current flow from +32 volts through the solenoid coils causing the solenoids to energize. Return diodes are used to protect the driver transistor from damaging high voltage transients as the coil fields collapse.

4.4.1.4 I/O Control and Data Storage

Data bits DT1 through DT7 (7060) are received at the input buffer from the CPU. At the buffer output, the seven bits are monitored to decode all functions. When a function is decoded, the control logic sets the Busy flip-flop L37(E,11) and executes the function. At the completion of the function, an Acknowledge pulse L1-10(E,7) is sent to the external device. If the input from the CPU is a printable character, then it is shifted into the 112-bit register by the control logic. An Acknowledge is sent to tell the CPU (the external device) that the character was received and the Printer is ready for the next input.

Function codes are not shifted into the 112-bit registers L9, L19, L25, L8 (K,7) with the exception of carriage return which is used during shift out to terminate printing (b6 and b7 outputs schematic 6761).

Upon receiving a CR code L33-6 (I,8), or detecting the marker bit at the shift register output (L8-7 to L7-8 to J & K inputs of L6), the print cycle is initiated by L36-8 gate (G,6). Characters are shifted out through the output buffer to be printed. By monitoring the shift register output, the print cycle is terminated by the control logic (b6 and b7 schematic 6761).

4.4.1.5 Prime Circuits Operation

When power is applied to the printer, C12 (18 uf) charges through R55 (G,10) (56K). This causes inverter L5-6 to go low after C12 charges to TTL level. L11-4 (G,11) is high at this time and L2-8 goes high to fire one-shot, L10-7 (H,11). The duration of this one-shot is approximately 3.3 ms to activate the prime circuit. POP sets the 1st character CR Latch and resets the paper movement flip-flops L9 on 6761 (D,11).

The prime circuit may also be activated by CIP, DELETE, RESET and CLEAR. Any one going low will cause L42-8 (H,12) to go high, firing L10-9 (H,11) one-shot for 3.3 ms. L2-11 (H,10) acts as a negative OR circuit as either one-shot L10-9 or L10-7 will cause L2-11 to go high for 3.3 ms.

When L2-11 the Prime Gate (H,10) goes high, L5-8 inverter will go low to reset JK flip-flop L6-9 low. L5-8 will also be used to set the L17 (6,9) Prime Latch. CLR the inverter output of L6-8 is used to reset EC (Expanded Character) flip-flop (H,4); clear the column counter L5(H,5) on the 6761 board; clear the MKR flip-flop L6-12 and goes to L26-12 Busy Gate (F,11) to generate a busy signal. It also serves to clock paper-out latch L21(E,13) via L22-1 Nand Gate (D,13).

4.4.1.6 Marker Bit Circuits (7060)

The following paragraph describes the clearing and loading of a marker bit in bit position number 8 of the 112-bit shift register L8-7 (J,7). A marker bit is used for two purposes. It indicates the position in the print buffer of the first character to be printed and indicates when the print buffer is full (contains 112 characters to be printed). In the the prime routine, the marker bit is placed in the first position of the shift register after all random bits have been shifted out and replaced by zeroes.

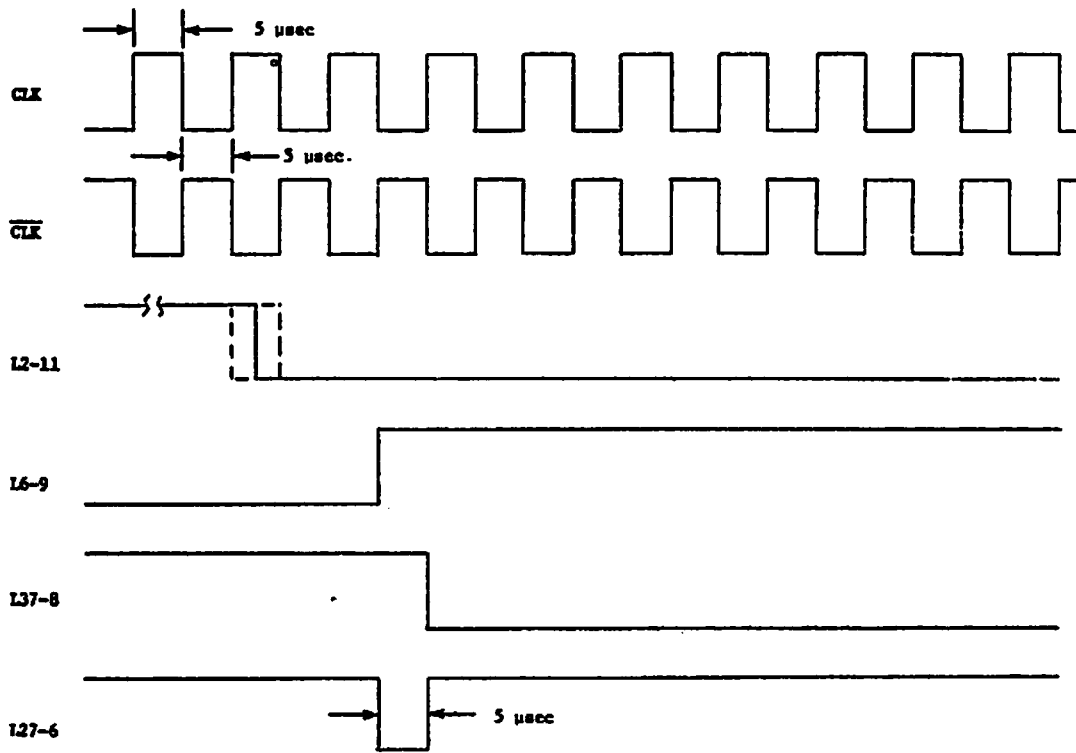

FIGURE 4-8 MARKER BIT GENERATOR

With L6-9 JK (H,9) low, L37-8 JK (G,8) will be kept high enabling L27-3 Nand Gate to follow $\overline{\text{CLK}}$ (E,12). The Shift Gate inverter output (H,7) will follow $\overline{\text{CLK}}$ firing PG L3-10 (I,7) on each leading edge. L3-10 is used as a shift clock for the 112-bit registers. Since bit DT8 (D,14) at L27-8 (I,8) is low during this time, zeroes will be shifted into the (D8) position of the shift registers, clearing out any Markers. The preceding conditions will exist until the L10 3.3 ms

one-shots time out. At that time, L6-9 JKFF (H,9) will be set by the trailing edge of the CLK. A marker bit, at MKR L27-8 (I,8) gate, will exist at this time (Figure 4-8) and the leading edge of CLK will shift it into the first register L9 (J,7). At the trailing edge of CLK, L37-8 (G,8) goes low to inhibit MKR L27-8 (I,8) gate, and also to inhibit any more shift clocks via Busy Gate L25-8, via L27-3 Nand Gate (F,11), and Busy FF L37-12 (E,11). CLR goes back high to release the Busy circuit. The logic is now initialized, and a marker bit is in the first position of the shift register. When selected by the CPU the printer is ready to receive inputs.

4.4.1.7 Select Circuit Operation

Before accepting any data, the printer must be selected. This is done by depressing the select switch on the control panel.

When the select switch is depressed, a low is applied to pin R₁ (G,14) setting the Select Latch L36-7 (G,13) high. Upon releasing the select switch, a low is applied at pin 14₁ (G,14) and resets the Select Latch. On the negative edge of L36-7, PG L36-13 (F,13) fires to clock Select flip-flop L21-9. With SL high, the Busy circuit, via L36-9 and L22-8 to Busy Gate L25, is released and other gates are enabled. A lamp inside the Select Key is lit and a select status bit SL is provided at the I/O interface. Prime Latch, L17-13 (G,9), is gated with SL at L22-8 (F,12) for a Busy condition. Set low at the end of each print cycle, the Prime Latch sets with the receipt of the first printable character. If the printer is deselected during buffer loading, then a low on L22-11 (G,9) will inhibit L22-9 from causing a Busy at this time.

The printer may be selected and deselected alternately by pressing and releasing the Select Switch. Also, note that SL latch is cleared by the power-up circuit L2-8 (G,11) to keep the printer deselected at power-on.

4.4.1.8 Print Buffer Loading Operation

Data bits, DT1 through DT7, are buffered and presented at the inputs of the shift registers L19, L9, L25, L8 (J,7) and the function decoders L34, L35, L32, L42, L33 etc. L35-8 (I,11) decodes the bell function or audio alarm. L34-8 (I,12) decodes the delete function. L33 (I,8), a BCD-TO-DECIMAL decoder, decodes line feed, vertical tab, form feed, and carriage return. L32-12 (I,10) decodes any function or character in the range of Hex (00) to Hex (1F) except for carriage return. The output is used to inhibit the loading of functions in the shift registers. Note that all function decoders are gated by $\overline{\text{DSTB}}$, and that the duration of each output will be a direct function of the pulse width of $\overline{\text{DSTB}}$.

$\overline{\text{DSTB}}$ is used to fire $\overline{\text{ACK-DLY}}$ one-shot (E,9) and to generate PS at L32-6 (I,10) to clock the shift registers via the L12-8 shift gate (H,7). $\overline{\text{DSTB}}$ is gated with L32-12 (I,10) function decode-output and if low, $\overline{\text{DSTB}}$ will not get through. For printable characters, L32-12 is high and PS is generated. PS resets L17-13 prime latch, resets 1st character CR latch low and causes shift gate L12-8 to go high. On the low-to-high transition L3-10 (I,7) PG is fired to shift in the character that is setting on the input lines (output of buffers).

$\overline{\text{ACK-DLY}}$ is low for a 7-usec duration. If the character at the input didn't cause a busy condition, then the trailing edge of $\overline{\text{ACK-DLY}}$ will fire the $\overline{\text{ACKLG}}$ one-shot via L2-6. If a busy condition did exist longer than 7 usec, then $\overline{\text{ACK-DLY}}$ will be generated by the trailing edge of RDY/BSY. $\overline{\text{ACKLG}}$ may be used to initiate the next $\overline{\text{DSTB}}$ on the sending device.

4.4.1.9 READY/BUSY Circuit Operation

The BUSY circuit is used to indicate to the sending device that an operation is in process. It also inhibits the $\overline{\text{ACKLG}}$ pulse from allowing the printer to become ready before more input is accepted. See 7060 Schematic.

The following conditions will cause the busy flip-flop, L37-12 (E,11) to go low or busy:

1. $\overline{\text{CLR}}$ (H,8) - prime circuit is active (L26-12)
2. $\overline{\text{BL}}$ (F,11) - 1.1 second audio alarm active (L26-10)
3. $\overline{\text{CO}}$ (F,14) - gated with Prime Latch or Marker Detect F/F (L26-9)
4. $\overline{\text{SL}}$ (G,14) - select status gated with Prime Latch or Marker Detect F/F (L26-9)
5. LF (G,5) - paper feed in process (L38-1) (D,12) (7060)
6. $\overline{\text{CF}}$ (D,14) - carriage forward indicating device is printing (L38-5) (D,12) (7060)
7. MKR (H,6) - buffer full condition (L38-2)
8. CR (G,6) - Latch set (L38-4)
9. PAPER OUT SW - paper out sensed (L26-13) (F,11) Busy Gate 2

$\overline{\text{LF}}$, $\overline{\text{CF}}$, $\overline{\text{CR}}$ Latch and $\overline{\text{MKR}}$ are negative ORed by gate L38-6 (D,12). Any low input will cause L38-6 to go high and inverter L39-6 to go low. This low is applied to D3 and negative ORed with other inputs by expandable gate L26-8 (F,11) Busy Gate 2. Again, any low input will cause L26-8 to be high, giving a low on busy latch clear input, keeping it busy.

PAPER-OUT from L21-13 (E,12) and BELL from L35-8 (I,11) are negative ORed by L28-6. This gate serves to generate an audio alarm, MA, and a busy condition by L39-12 inverter and L26-8 Busy Gate (F,11).

Cover Open ($\overline{\text{CO}}$) and $\overline{\text{SL}}$ are negative ORed at L36-9 (F,12) and Nanded with output of L22-11 (G,9) (negative ORed PRIME LATCH and MKR). This delays setting of the BUSY F/F L37-12 (E,11) by a cover open or a deselect condition until after buffer registers finish receiving the current line of data being inputted and the line has been printed.

The busy latch is set to READY on the first $\overline{\text{CLK}}$ after the busy condition is removed.

4.4.1.10 Print Cycle Operation

The print cycle is initiated by detecting a print buffer full condition or decoding a CR at the input. See 7060 Schematic.

Buffer Full Print Cycle

As each character is shifted into the buffer, the marker bit is shifted along ahead of the data. When 112 printable characters have been inputted, the MKR bit is sensed by MKR flip-flop L6-12 (H,6) via L8-7, L7-8 to L6-14 thru an inverter L5. $\overline{\text{MRK}}(Q_1)$ goes low to set printer busy. $\text{MRK}(Q)$ goes high to enable print gate, L38-8 (G,5). $\overline{\text{PRINT}}$ sets logic on the 6761 board to start the carriage moving. As the timing disk passes the magnetic pickup, print timing pulse 1, G_1 (K,4) is generated and the character at the buffer output b1 through b7 is printed. Each time the magnetic pickup senses five teeth $\overline{\text{SF6}}$, pin 1₃ (7060) (H,8) goes low generating a shift clock L12-8 (H,7) to shift out the next character. After printing the 112th character, the carriage magnet closes $\overline{\text{SW2}}$ 6761 (H,8) (right-most reed switch)) to reverse the servo logic. $\overline{\text{CIP}}$ from the 6761 board generates a prime condition on the 7060 to initialize the printer for a new line of data by L2-11 generating a 30 ms Prime Gate.

Decoded Carriage Return Print Cycle

When a CR code is received at the input and less than 111 printable characters have been shifted into the registers, CRP (decoded by L33-5) initiates the print cycle. Since the first character to be printed could be in any one of the 111 register positions, some means must be used to shift it to the output before carriage movement is initiated.

Upon decoding a carriage return at the input buffer, CRP goes low sets CR Latch L17 (G,6). On the trailing edge of $\overline{\text{DSTB}}$, CRP goes high and produces a low on L24-6 (G,8). This causes a busy condition, and holds inverter L11-2 high to enable shift control gate L12-6 (F,8). For each $\overline{\text{CLK}}$, a low is generated at L12-6 which causes Shift Gate

L12-8 (H,7) to go high. Thus, L3-10 (I,7) PG is fired at each CLK until the marker is sensed at the output of the shift register. At this time Marker Detect F/F sets and inhibits the Shift Control Gate L12-6 stopping the shift pulses. It also enables the Print Gate which initiates forward carriage motion.

When the carriage-return code is shifted to the shift register output, it indicates that all the characters have been printed. Rather than wait for the carriage to activate the right reed switch, time may be saved by returning it from its present position. CR code is detected at the output of the shift registers by NOR Gate L39-6 (G,13) on the 6761 board at Print Pulse 2 (G2) time*. On return, CIP causes a prime routine to ready the printer for another line of input.

4.4.1.11 Audio Alarm Operation

The audio alarm is produced by the following conditions. See Figure 7060.

1. Power-on circuit action
2. On receipt of Bell code, Hex (07)
3. On sensing paper-out condition

BELL, PAPER-OUT and Limit Latch (set) are gated at L28-6.** (C,13). When any of the three conditions occur, L1-6 on the 6761 (J,3) one-shot is triggered for a duration of 1.1 seconds by MA. This gates the output of the Alarm Oscillator to the audio amplifier on the 6761 board. The frequency of the audio signal is approximately 300 Hz. Transistor Q4 in the one-shot L1-6 circuit is necessary when a large value RX_1 is used for such a large time constant.

* Actually decodes any code between Hex (00) and Hex (1F) but only a CR code Hex (0D) can be shifted into the buffer.

** Note: The Limit Latch circuit was used to indicate a carriage malfunction. It is presently not in use.

4.4.1.12 Cover Open Operation

See Schematic 7060. When the front cover is opened, pin P_1 (F,14) goes low. \overline{CO} is negative ORed with \overline{SL} and NANDed with Prime Latch or Marker Detect F/F to cause a busy condition. If the cover is opened during buffer loading, L22-11 (F,9) will be low and inhibit the busy. When CR code is received as a line terminator and the marker is detected at the shift register output, L22-11 will go high to enable L22-8 (F,12) causing a busy via Busy Gate 2 (F,11).

4.4.1.13 Paper-Out Switch Operation

While paper is moving over the PAPER-OUT SW actuator, the switch remains open. See Schematic 7060. When the end of the form passes the switch, the switch closes making pin 10_1 low. Paper out F/F, L21-12 (E,12) will set upon receiving a clock via L22-3 (E,13) gate. Either LF (G,5) or \overline{CLR} (H,8) will provide this clock to set the latch. L21-13 (Q) is buffered and PO is made available at the I/O interface for monitoring. Q_1 is also used to trigger the alarm one-shot via MA and to cause a busy condition. The Q output is buffered and used to turn on the paper-out light.

4.4.1.14 Form Override Operation

See Schematic 7060. (FOR) (E,14) switch applies a low to the clear input of the L21 Paper Out F/F (E,13). If the switch is released, the latch will again set by LF or \overline{CLR} . The latch cannot be set as long as the override switch on the front panel is held down.

4.4.1.15 Servo Alarm Light Circuit Operation

The servo alarm light is connected across (in parallel) the servo motor fuse. The lamp only illuminates when servomotor fuse is open.

4.5 2231W-3 PRINTING & PLOTTING OPERATION

Equipment configuration for the 2231W is: 2282 plugs into the 2200 controller board where the printer was normally connected, and the 2231W-3 plugs into the 2282 output connector. For normal print operation (character & symbols) the information sent out on the controller board is directed to the printer and will print out as if there were no Graphic CRT present. Plotting operations are intercepted by the Graphic CRT and displayed. The plotting operations will not be received directly by the printer.

The 2231W-3 is a modification of the 2231W printer. The modified printer provides a plotted output in addition to conventional (ASCII) printing capability. By sending a HEX (E7) code to the Graphics CRT, the image on the CRT is dumped into the printer for hard copy. This is accomplished by printing strips of 800 dots by 8 dots on the page until the image on the CRT is reproduced.

The 2231W-3 is also capable of being plugged directly into the printer controller board of the 2200. If a programmer followed the conventions used by the Graphics CRT, he could drive the printer as if it were a plotter by using \$GIO commands. In general this is accomplished by storing on disk an array image of the CRT screen, and using \$GIO commands to send the image to the printer. Each eight "rows" of the image corresponding to one of 64 rows on the printer output.

The printer provides a R/B status line (C,9) which indicates that the printer's power is on, selected, and operational ready for data (See schematic 6795). The printer also provides to external equipment an acknowledge strobe (C,9). The R/B status line and acknowledge strobe from the printer, control a R/B status bit in the electronics of the 2282 that can be read by the 2282. The 2282 software will only write to the printer when this status bit is off (ready).

When the printer is ready, the 2282 sends its contents in the accumulator to the printer in terms of DT1 through DT9. This automatically turns the R/B status bit on to indicate that the printer is busy. When the printer has received the character and either stored it in its buffer or processed it (letters and symbols are stored - dots are processed immediately), the printer sends back an acknowledge strobe. This action returns the R/B status bit to ready.

4.5.1 Conventional Printing

When the printer's buffer (L15 thru L18) becomes full, (132 characters), or a carriage return is encountered, the printer automatically prints the contents of the buffer. During the printer operation, the printers' R/B status bit goes to busy, and stays there while the printer prints the line, does a carriage return and a line feed of 1/6 inch. The R/B status bit then returns to ready.

During the period, the printer input signals DT1 thru DT8 are decoded and characters stored in the 132 bit shift registers (K,13). The serial output of the L15 thru L18 shift registers is used to generate the printing characters in the ROM's, the dual L11's (J,6).

Non-expanded characters are fed directly to the multiplexers L41 and L54 (J,4). The odd solenoids are fed directly through Nand gates. The even solenoids are fed through delay shift registers (L53, L52) (I,3) then Nand gates.

4.5.2 Plotting Mode

The 2282 puts the printer (2231W-3) in the plotting mode by sending a command HEX (08). Neither the plot command itself, nor subsequent bit patterns that are to be printed, will be acknowledged with an acknowledge strobe.

The printer immediately starts the print head moving, and when it is moving up to speed, the printer starts sending acknowledge strobes every 0.8 milliseconds. These acknowledge strobes are used as timing

marks by the 2282 which sends a byte of data in response to each strobe. When a data byte is received by the printer, the eight data bits are printed by the eight solenoids of the print head.

When the last data byte is printed on a line, a carriage return/line feed command is automatically sent to the printer by the controller microcode. The size of the line feed is controlled by a selection switch located within the printer and can be overridden by the microcode a line at a time.

The byte at a time from the 2282 through the controller is immediately processed through the inverters, the universal shift registers, L55 and L68, to the multiplexers, L41 and L54, without storage as is done by the 132 bit shift registers in the printer's conventional printing mode.

SECTION 5
ADJUSTMENT, REMOVAL AND REPLACEMENT PROCEDURES

5.1 INTRODUCTION

This section pertains to the adjustment, removal and replacement of the major mechanical assemblies in the 2231W-1/2/3 printers. Procedures peculiar to the 2231W-3 will be discussed separately. Reference to the illustrated parts list in Section 8 will be helpful during the performance of procedures.

Prior to the removal and replacement of suspected mechanical components, the mechanical assembly in question should be checked for proper adjustment. Should adjustment check show out-of-tolerance operation, the corresponding adjustment procedure should be attempted next. Should adjustment fail to correct the problem, part removal and replacement may be necessary. The procedures to remove and replace a given part or parts are provided herein right after the check and adjustment procedures. Adjustment and or alignment procedures should also be performed after the assembly procedures of a given mechanical section. Of course, assembly procedures are the reverse order of removal and replacement procedures.

5.2 ELECTRICAL ADJUSTMENTS (REFER TO FIGURE 5-1)

5.2.1 Check, and adjust if necessary, first character position per Section 5.3.9.

CAUTION:

To perform the following print timing adjustments the print head should be disconnected electrically.

5.2.2 Print Head Adjustment - To prevent damage to the print head while making the following adjustments, disconnect the print head electrically by disconnecting the finger board which plugs into print head ribbon cable. Then run a program for continuous printing. Each adjustment required for print timing is listed in Table 5-1. Perform the +5VR adjustment before proceeding to print timing.

5.2.2.1 WS Adjustments - (Figure 5-1) WS is generated by the timing disk teeth passing the magnetic reluctance pickup. This signal must be adjusted by R71 on the 6761 board (2231W-1,-2) and R67 on the 6794 (2231W-3) for a complete cycle of 1600 us +25 as monitored at L19 Pin 5 of the 6761 board on 2231W-1/2, and 6794 board on 31W-3 (negative trigger in noraml trigger mode). R10 must then be adjusted to obtain a squarewave (50% duty cycle).

5.2.2.2 After obtaining the proper waveform for WS (Figure 5-1), the following pulses should be checked and/or adjusted.

WS trailing edge - Adjust R19 on the 6761/6794 boards for a 550-560 us negative pulse at L19 pin 7.

WS leading edge - Adjust R19 on the 6761/6794 boards to obtain a 550-560 us negative pulse at L19 pin 9.

The WS leading and trailing edge strobes are only present during the printing period. Replace print head solenoid fingerboard connector.

5.2.2.3 To properly phase the signals from the two magnetic reluctance sensors, pivot the mounting plate holding the magnetic reluctance sensor for the index hole of the timing disk (Figure 5-17) for a difference of 800 usec +50 usec between positive edge of signal at L3 pin 12 and L3 pin 13 (positive edge of signal from L3 pin 13 is used to trigger oscilloscope sweep) for all models on 6761/6794 boards.

SCOPE: L19-5
 NEG. TRIGGER
 ADJUST: R71 (2231W-1,-2)
 R67 (2231W-3)

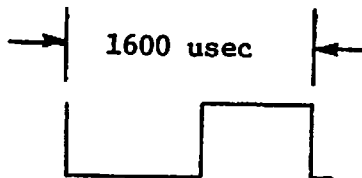

SCOPE: L19-5
 NEG. TRIGGER
 ADJUST: R10 (2231W-1,-2,-3)

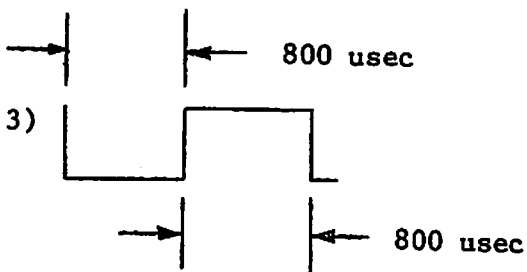

SCOPE: L19-7
 NEG. TRIGGER
 ADJUST: R22 (2231W-1,-2)
 R23 (2231W-3)

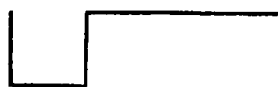

SCOPE: L19-9
 NEG. TRIGGER
 ADJUST: R19 (2231W-1,-2,-3)

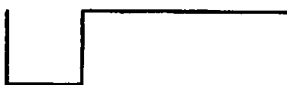

SCOPE: Channel 1 ~~L3-13~~ L3-13
 POS TRIGGER
 Channel 2 L3-12
 ADJUST: Pivot Plate
 6761 (2231W-1,-2)
 6794 (2231W-3)

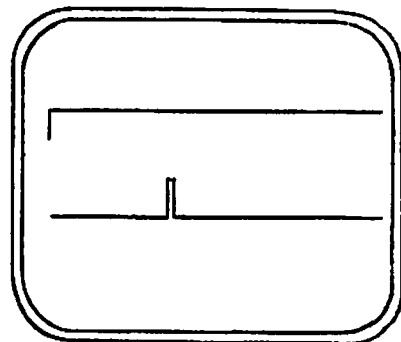

FIGURE 5-1 WS TIMING ADJUSTMENT

TABLE 5-1

LEVEL OR SIGNAL	BOARD	LOCATION	MEASUREMENT	ADJUSTMENTS	
				2231W <u>-1,-2</u>	<u>2231W-3</u>
+5VR	6756	Pin C ₁	+5 volts \pm .25 volts	R24	R24
WS	6761	L19 pin 5 (K,11)	1600 us \pm 25 us full cycle	R71	R67
	6794	L19 pin 5	square wave 50% duty cycle)	R10	R10
WS(TRAILING EDGE	6761	L19 Pin 7	550-560 us negative	R22	R23
	6794		pulse		
WS(LEADING EDGE	6761	L19 Pin 9	550-560 us negative	R19	R19
	6794		pulse		
INDEX	6761	Ch. 1 L3 (J,9)	L3 pin 13 (TPE ₁) should lead	Pivot plate (magnetic sensors) mounting)	
	6794	pin 13 and	L3 pin 12 (TPF ₁) by 800 us		
		Ch. 2 L3			
		pin 12 (Trig. Ch. 1)			

6794/7894

□ □ □ □
R19 R23 R10 R67

NOTE:

Whenever the 6761 or 6794 boards are changed, all electrical adjustments must be checked. All timing pots should be secured with Glyptal after adjustment to prevent any changes due to vibrations in the printer.

The complement of Electrical Circuit Boards used in the 2231W-1, 2231W-2 and 2231W-3 are listed in Table 5-2. Refer to Figure 5-2 for locating the position of Electrical Circuit boards on the Electrical Chassis Assembly of all models.

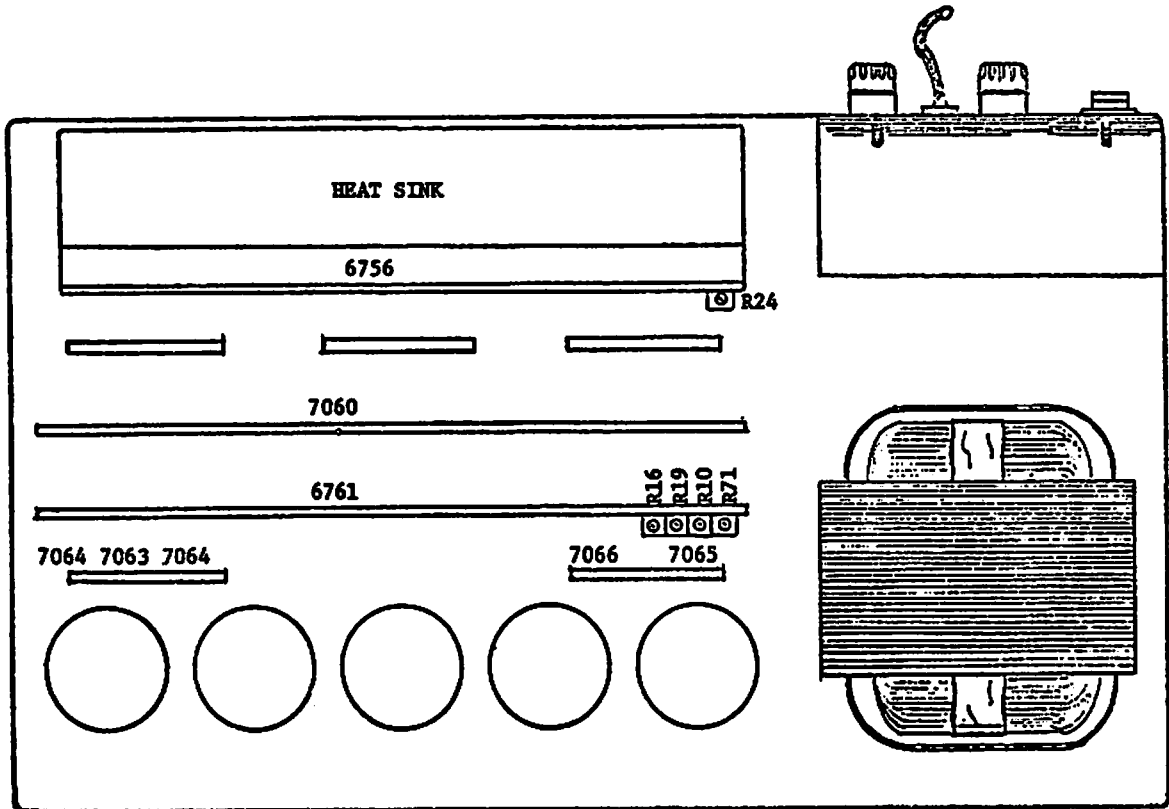

FIGURE 5-2 ELECTRICAL CHASSIS ASSEMBLY LAYOUT

5.2.2.4 2231W-3 Adjustments

The 2231W-3 is identical in all adjustment procedures to the 2231W-1-2 except on plot mode. SW3 carriage switch is the right hand magnetic limit switch which is used in plot mode only. Since character mode is 14.4" pitch a full line of characters (132) or full line expanded (66) will stop short of SW3. It is not used in the normal printing mode, only plotting. This switch is simply moved to the right far enough to print all 800 X dots yet not so far as to slam the carriage into the stop.

TABLE 5-2

	<u>ELECTRICAL CIRCUIT BOARDS</u>			<u>PART NUMBER</u>
	<u>2231W-1</u>	<u>2231W-2</u>	<u>2231W-3</u>	
1) Timing and Format Control	6761	6761	6794/7394	
2) I/O, Data Storage	7060	6760	6795	
3) Power Driver Board	6756	6756	6756	
4) Print Head Finger Board	6758	6758	6758	
5) Motherboard	6757	6757	7157	
6) Print Head Cable Fingerboard	6759	6759	6759	
7) Center Panel Fingerboard (6 X 2)	7062	7062	7062	
8) Read Switch Fingerboard (5 X 2)	7063	7063	7063	
9) Format Control Fingerboard (4 x 2)	7064	7064	7064	
10) Panel Switch Board	6762	6762	6762	
11) Power Selection Switch (115V/230V)	6749	6749	6749	

5.3 MECHANICAL AND ELECTROMECHANICAL ADJUSTMENT, REMOVAL/REPLACEMENT INDEX FOR 2231W-1/2/3.

- 1) Paper Guides
- 2) Head Adjustment Arm
- 3) Striker Plate and Platen Brackets
- 4) Main Drive Belt
- 5) Print Head
- 6) Ribbon Clutch Assembly and Cartridge Guides
- 7) Reed Switches and Mounting Bracket
- 8) Reed Switch Magnet
- 9) Magnetic Reluctance Pickup and Timing Disk (First Character Position)
- 10) Paper Feed Sprockets and Paper Guide Cover
- 11) Horizontal Vernier Clutch Paper Advance
- 12) Paper Movement Gears
- 13) Vertical Format Unit (VFU)
- 14) Carriage Servomotor
- 15) Carriage Assembly Removal and Replacement
- 16) Electronic Assembly Cover Removal and Replacement
- 17) Cover Removal and Replacement

5.3.1 Paper Guides (Figure 5-3)

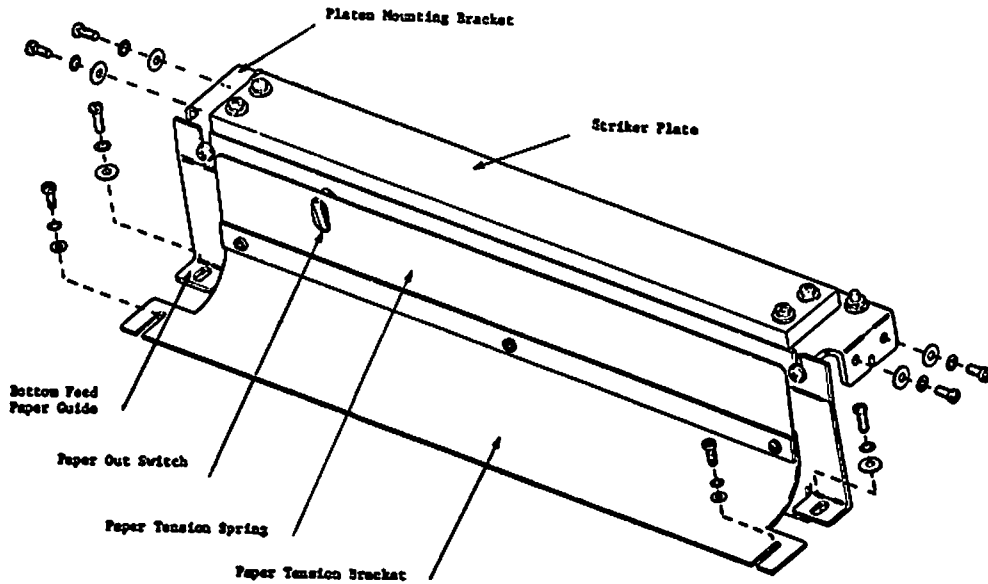

FIGURE 5-3 PAPER GUIDE ASSEMBLY

5.3.1.1 Adjustment Checks

- 1) The paper tension spring must be parallel to the bottom feed paper guide across its entire length.
- 2) The point at which the paper exits from the paper tension spring should be the only place where the spring contacts the bottom feed paper guide. This may be difficult to see, so it is suggested that a piece of paper be pushed squarely through the front feed or bottom feed paper guides as if paper was being loaded. In doing this a slight resistance should be felt along the entire width of the paper just as the paper begins to appear at the front of the machine.

- 3) As a single sheet of paper is pulled upward through the paper tension spring, check for a two ounce (57 gram) force applied to pull paper to produce movement. (An 8 part form, or 8 sheets of paper, should not bind when pulled through.)

5.3.1.2 Adjustment

Loosen the two screw holding the paper tension bracket and move it forward or backward parallel to bottom feed paper-guide to achieve the proper tension.

5.3.1.3 Removal and Replacement (See Figure 5-3)

- 1) Remove striker plate (Section 5.3.3).
- 2) Remove paper out switch wires.
- 3) Remove print head mounting screws and lift print head clear of carriage. (See Figure 8-1 of Section 8.)
- 4) Remove four bottom feed paper guide mounting screws and guide.
- 5) Loosen two paper-tension-bracket mounting screws and remove bracket and spring assembly.
- 6) Reverse procedure to reassemble.

5.3.2 Head Adjustment Arm (Figure 5-4)

5.3.2.1 Adjustment Check

- 1) Move head adjustment arm to position 5 and check that allen screw in carriage shaft is vertical.

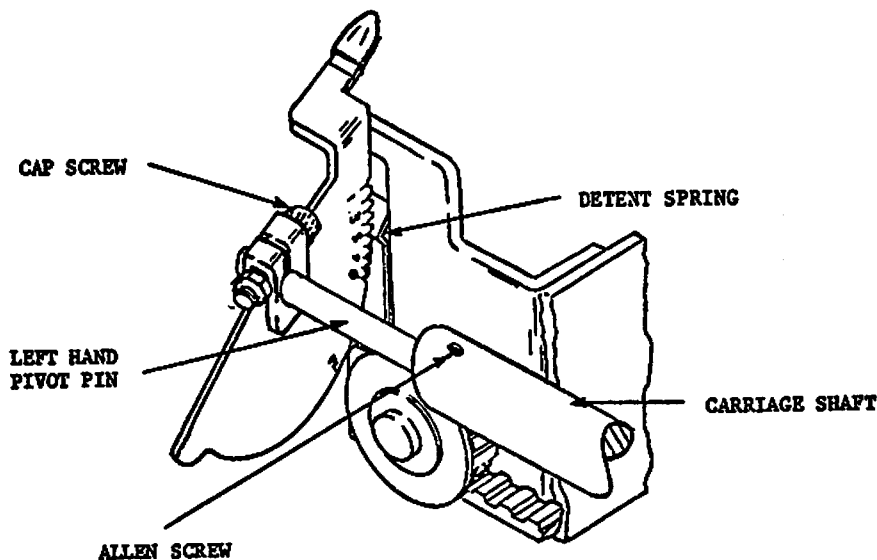

FIGURE 5-4 HEAD ADJUSTMENT ARM ASSEMBLY

5.3.2.2 Adjustment

- 1) Rotate carriage shaft so allen screw is vertical.
- 2) Loosen allen screw holding left hand pivot pin.
- 3) Place head adjustment arm (on left-hand pivot pin) to position 5, center arm on detent spring and tighten allen screw.
- 4) Check striker plate adjustment (Section 5.3.3).

5.3.2.3) Removal and Replacement

- 1) Loosen allen head cap screw and nut on head adjustment arm and slide lever off end of pivot pin. (for carriage shaft removal, see Section 5.3.15).

5.3.3 Striker Plate and Platen Brackets (Figure 5-5)

5.3.3.1 Adjustment Check

- 1) With the print head in the far left carriage position and ribbon cartridge removed, move the head adjustment arm to position 1 (move the print head as close as possible to the striker plate). A .013" (.33 mm) gauge should just fit between the striker plate and the solenoid wires.
- 2) Move the head to the far right carriage position and check for the same gap.

5.3.3.2 Adjustment

Fine Adjustment

- 1) Move the head adjustment arm to position 1.

- 2) Remove the ribbon cartridge from the print head to allow for proper measurement (Section 3.3).
- 3) Loosen the four Phillips head screws holding the striker plate to platen mounting brackets.
- 4) Adjust the striker plate in-or-out to meet adjustment tolerances.

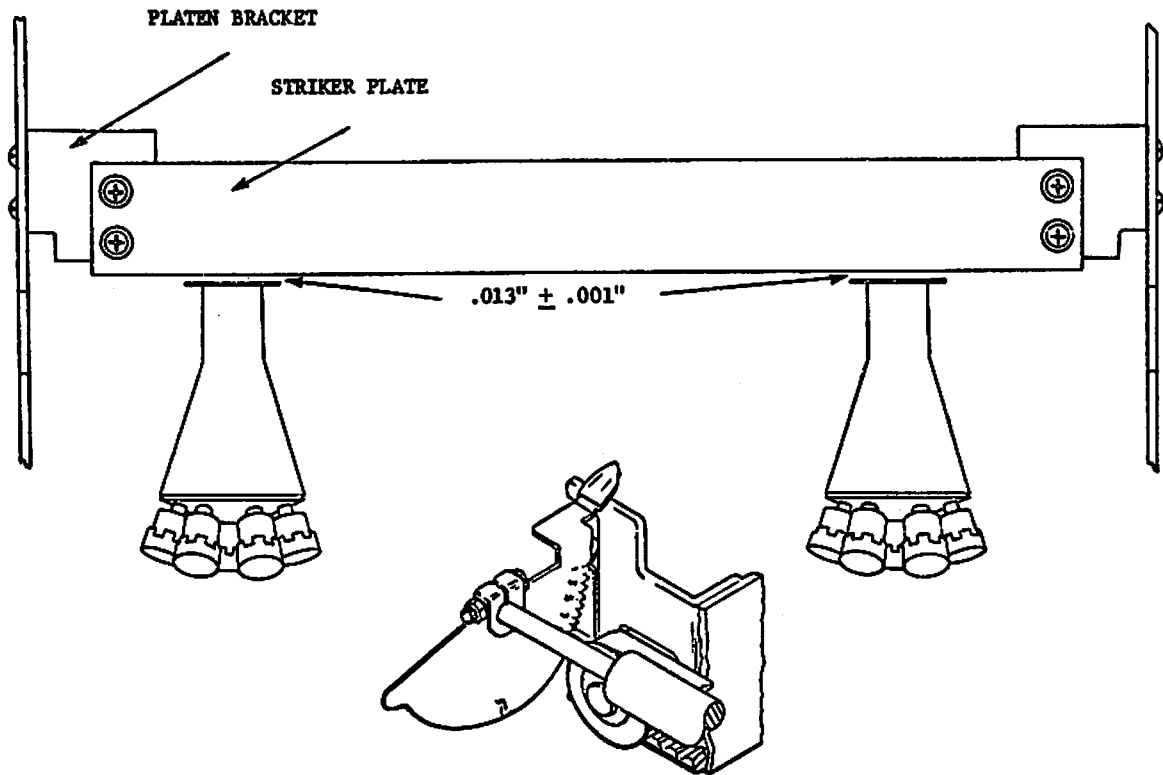

FIGURE 5-5 STRIKER BAR ADJUSTMENT

Coarse Adjustment (if necessary)

- 1) Loosen the four screws holding the striker plate to the platen mounting bracket; slide striker plate to front of printer and retighten screws.

- 2) Move print head to left side of printer and set head adjustment arm to position 5.
- 3) Loosen two screws holding platen mounting bracket on left side frame and adjust in-or-out for a gap of .013" (.33 mm) between striker plate and solenoid wires. Tighten screws.
- 4) Repeat step 2 and 3 for right side.
- 5) Check paper guide adjustment (Section 5.3.1).
- 6) Perform striker plate fine adjustment step 1 to 4.

5.3.3.3 Striker Bar Removal and Replacement

- 1) Move the head adjustment arm to position L.
- 2) Remove the four Phillips screws that attach the striker plate to the platen mounting brackets.
- 3) Reverse procedure to reassemble and then readjust striker plate.
- 4) Check the paper guide adjustment (Section 5.3.1).

5.3.4 Main Drive Belt

5.3.4.1 Adjustment Check

- 1) Move the carriage to the extreme right hand position.
- 2) Using a spring gauge and scale, deflect the middle of the belt .31" or 5/16" (7.9 mm). The gauge should read 1 lb +2 oz (453 grams +57 grams). (Figure 5-6).

5.3.4.2 Adjustment

Loosen the 7/16" nut holding the main drive-belt-pulley on the left side of the printer. Move the pulley in the desired direction retighten the pulley nut. See Figure 8-7 of Section 8.

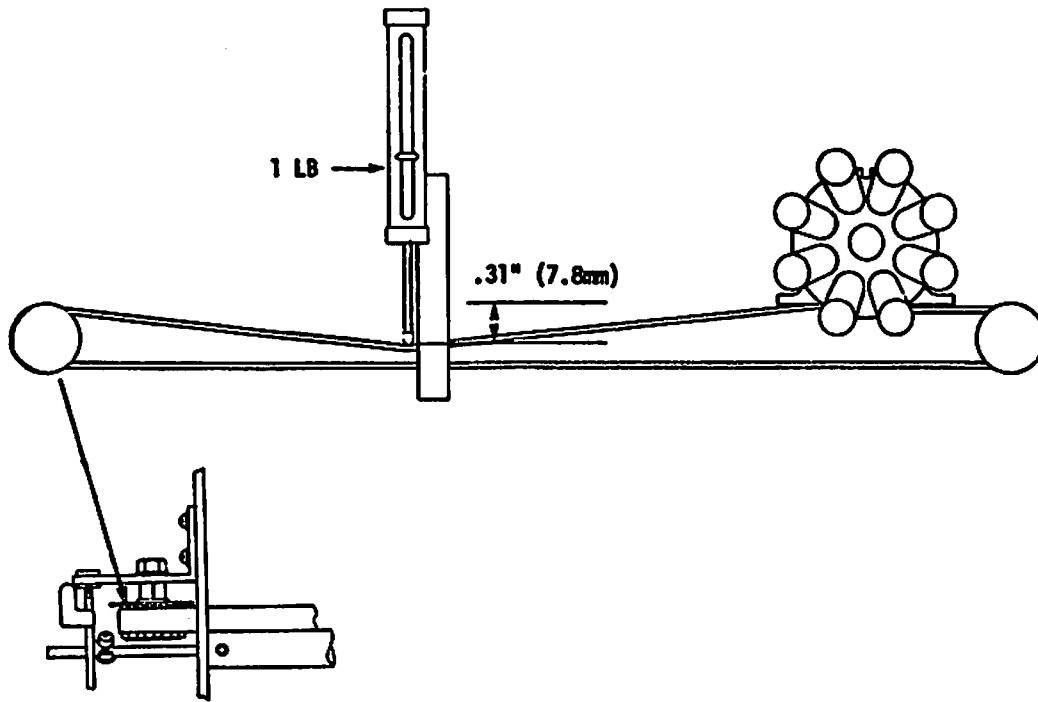

FIGURE 5-6 MAIN DRIVE BELT ADJUSTMENT

5.3.4.3 Removal and Replacement

- 1) Remove the carriage assembly (Section 5.3.15) (Figure 8-6 of Section 8).
- 2) Turn carriage assembly upside down, remove two belt holding plate screws and remove belt (Figure 5-7).
- 3) To replace reverse procedure.

5.3.5 Print Head Adjustment

5.3.5.1 Adjustment Check

- 1) Loosen mounting screw holding 6758 fingerboard retainer and rotate away from finger board.

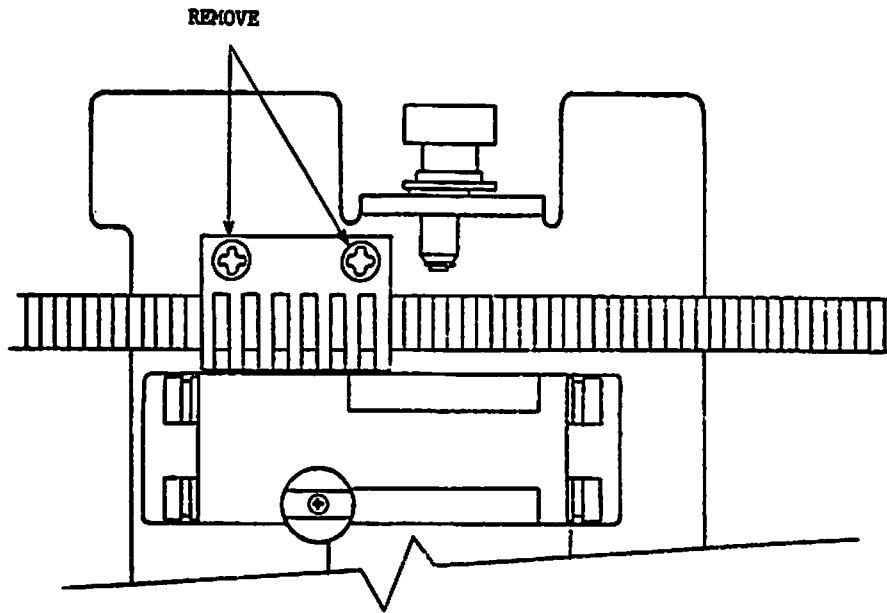

FIGURE 5-7 MAIN DRIVE BELT REMOVAL

- 2) Remove the print head from the carriage assembly by disconnecting fingerboard from connector and removing the two print head mounting screws.
- 3) With a jewelers loupe (magnifier) look at the head bearing (Figure 5-8). All the solenoid wires must be flush with the bearing surface.

NOTE:

When replacing solenoid fingerboard Wang
Logo faces front of printer.

5.3.5.2 Adjustment of Print Head

- 1) Remove the head cover by removing the two Phillips screws. See Figure 8-1 of Section 8.
- 2) Unlock the desired solenoid by loosening its corresponding nylon tip locking set screw WL #650-4086 (8-32 X 15/64). These screws are positioned radially at the rear of the print head. (See Figure 5-9)

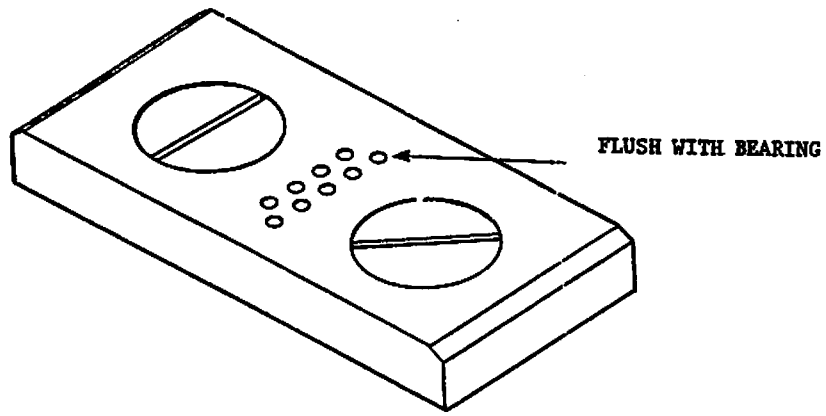

FIGURE 5-8 SOLENOID WIRE ADJUSTMENT

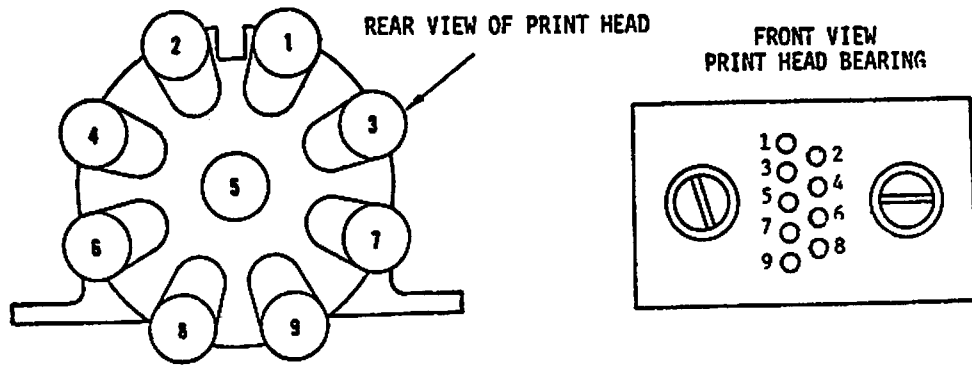

FIGURE 5-9 IDENTIFICATION OF SOLENOIDS

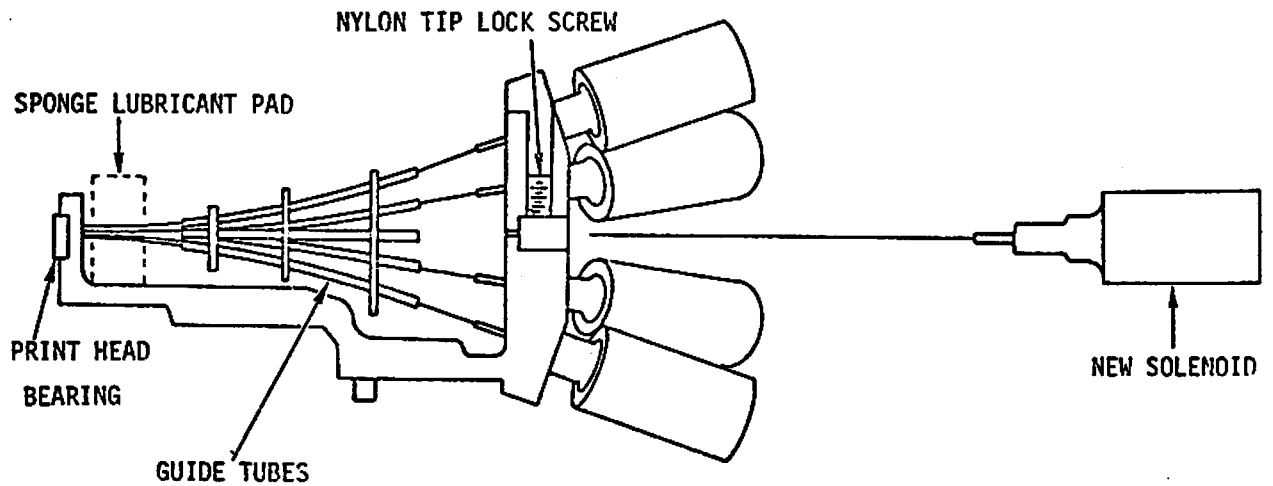

FIGURE 5-10 REMOVAL & REPLACEMENT OF SOLENOIDS

CAUTION

In step 3, while turning solenoid, grasp the metal body of the solenoid, not the plastic endcap. Using the endcap as a gripping point may damage the coil wires protruding from the endcap.

- 3) Turn the solenoid to be adjusted in or out while watching the solenoid wire at the bearing (Figure 5-10).
- 4) Tighten nylon tip set screw and check the bearing again.

5.3.5.3 Solenoid Removal and Replacement

NOTE:

If more than one solenoid requires replacement, only one solenoid should be removed, replaced and adjusted at one time.

- 1) Remove print head from carriage assembly by removing the fingerboard and the two screws holding print head to carriage assembly.
- 2) Remove print head cover; loosen 6758 fingerboard retainer bracket and remove 6758 fingerboard. See Figure 1 of Section 8.
- 3) Unsolder solenoid wires from 6758 fingerboard.
- 4) Loosen desired lock set-screw and unscrew solenoid from head casting (Figure 5-10).
- 5) Remove lubricant pad. Remove any broken wire material at pad location.

- 6) Cautiously insert the new solenoid being careful not to bend the new print wire. With a pair of tweezers (or springhook) guide the wire into its guide tube and then into its respective bearing hole. Relock the solenoid with the nylon-tip set-screw. Separating the two rows of print wires with a feeler gauge aids in guiding the new solenoid wire into the print-head bearing.
- 7) Solder solenoid wires to 6758 fingerboard.

CAUTION:

The next step is lubricating the new solenoid wire and the bearing. Lubrication is necessary or damage to the new wire will result.

NOTE:

When replacing 6758 fingerboard, Wang Logo faces front of printer.

- 8) Dip the lubricant pad into the lubricant material (obtained from Home Office; no other lubricant can be substituted) and place it back into the print head. Tip the head forward to allow the lubricant to reach the tip of the print wires.
- 9) Replace print head on carriage assembly and operate for several minutes to insure that lubricant is distributed (lubricant has a wax base and does not flow readily).
- 10) Replace print-head cover and tighten 6758 retaining bracket.

5.3.6 Ribbon Clutch Assembly and Cartridge Guides

5.3.6.1 Adjustment Check

- 1) The distance from the center line of the ribbon drive assembly to the inside front edge of the ribbon cartridge guides is 4.38 to 4.42 inches (11.12 cm to 11.23 cm) (Figure 5-11). Also see Figure 8-8 of Section 8.
 - a) Remove print head and insert alignment tool in print head pin-holes. Check that ribbon cartridge guides are flush with the forward edge of the alignment tool.
- 2) Check that the ribbon advance cable is properly seated on ribbon drive pulley (Figure 5-12 and 5-13).
- 3) Ribbon cartridge should lift free of ribbon cartridge spring with an upward force of 2 lbs +2 oz (960 grams +57 grams) applied to the rear of the ribbon cartridge.

5.3.6.2 Adjustment

- 1) Loosen allen screws and move ribbon cartridge guides in appropriate direction (Figure 5-11).
- 2) Loop ribbon advance cable around ribbon drive pulley so the cable is to the rear of the pulley (Figure 5-13).
- 3) Loosen hex head screws on bottom of carriage and move ribbon cartridge spring in appropriate direction (Figure 5-11).

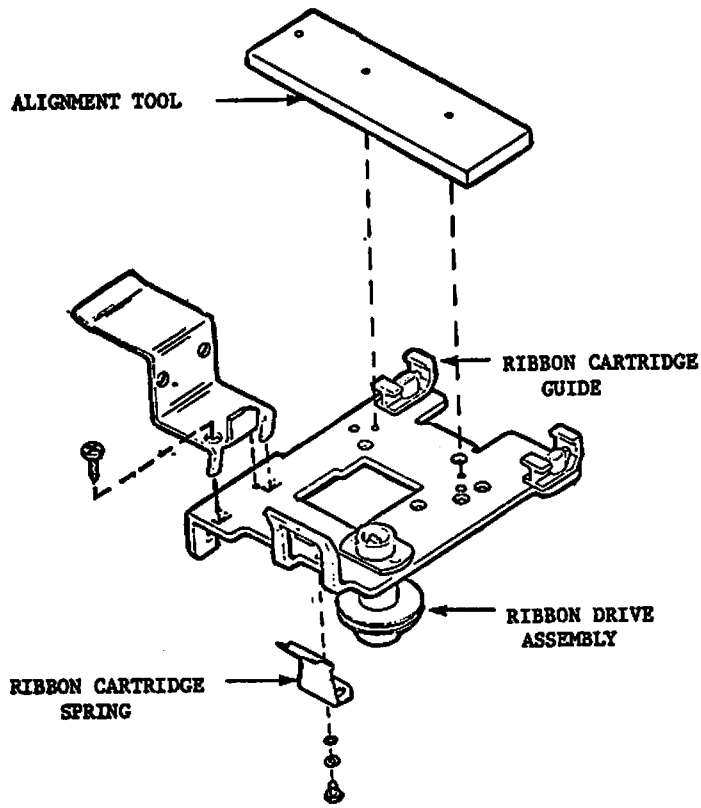

FIGURE 5-11 CARRIAGE ASSEMBLY

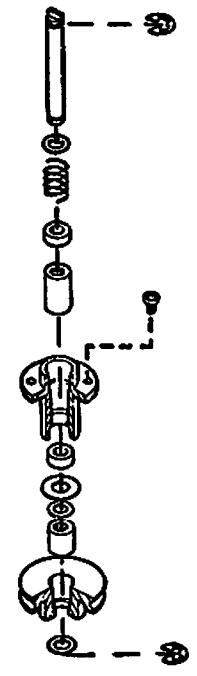

FIGURE 5-12 RIBBON DRIVE

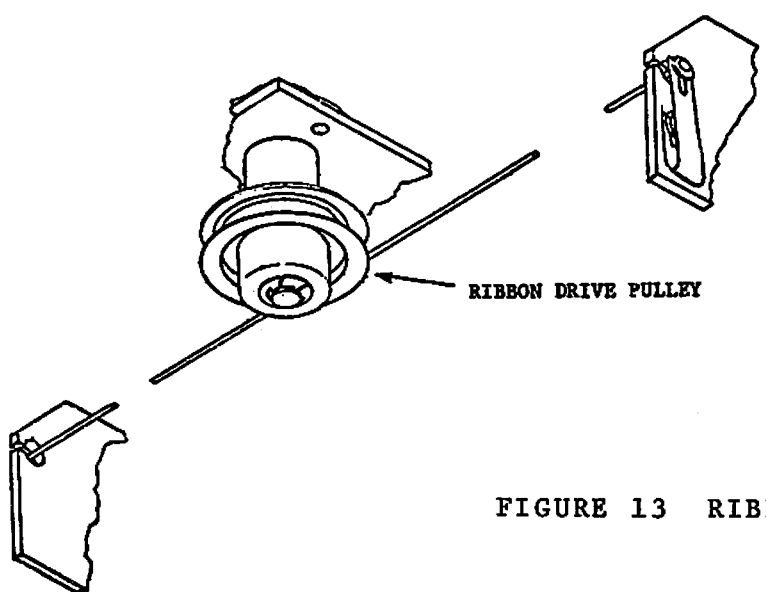

FIGURE 13 RIBBON ADVANCE CABLE

5.3.6.3 Removal and Replacement

- 1) Remove allen screw from center of cartridge guides.
- 2) Compress ribbon advance cable spring on right side frame and slide cable upward out of spring. Remove cable from ribbon drive pulley and slide out of left side frame (Figure 5-13).
- 3) Remove snap ring from bottom of ribbon drive pulley, remove 2 screws from top of ribbon drive assembly and pull through carriage assembly (Figure 5-12).
- 4) Remove ribbon cartridge spring screws from bottom of carriage assembly and slide ribbon cartridge spring out (Figure 5-11).
- 5) Reverse procedure to reassemble.

5.3.7 Reed Switches and Mounting Bracket (Figures 5-14, 15)

5.3.7.1 Adjustment Check

1) <u>FROM</u>	<u>TO</u>	<u>MEASURE</u>
Left side frame	Left side of SW ₀	1.70" \pm .015" (4.32 cm \pm .04 cm)
Left side frame	Left side of SW ₁	3.15" \pm .015" (8.00 cm \pm .04 cm)
Right side frame	Right side of SW ₂	.80" \pm .050" (2.03 cm \pm .13 cm)
Reed switch magnet	Top of SW ₀ /SW ₂	.060" \pm .015" (.15 cm \pm .04 cm)

NOTE:

SW3 for the 31W-3 is adjusted for proper operation by the procedure in paragraph 5.2.2.4.

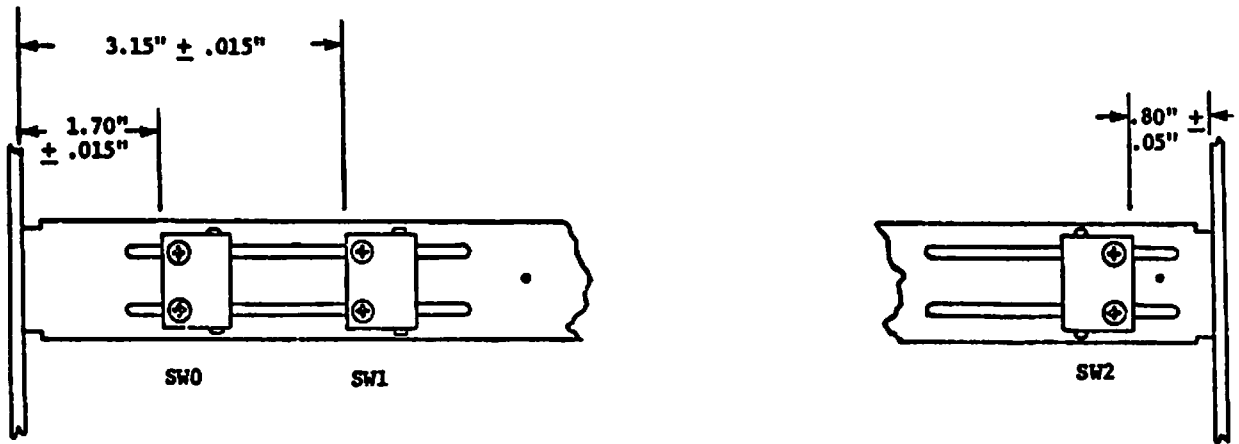

FIGURE 5-14 REED SWITCHES AND MOUNTING BRACKET

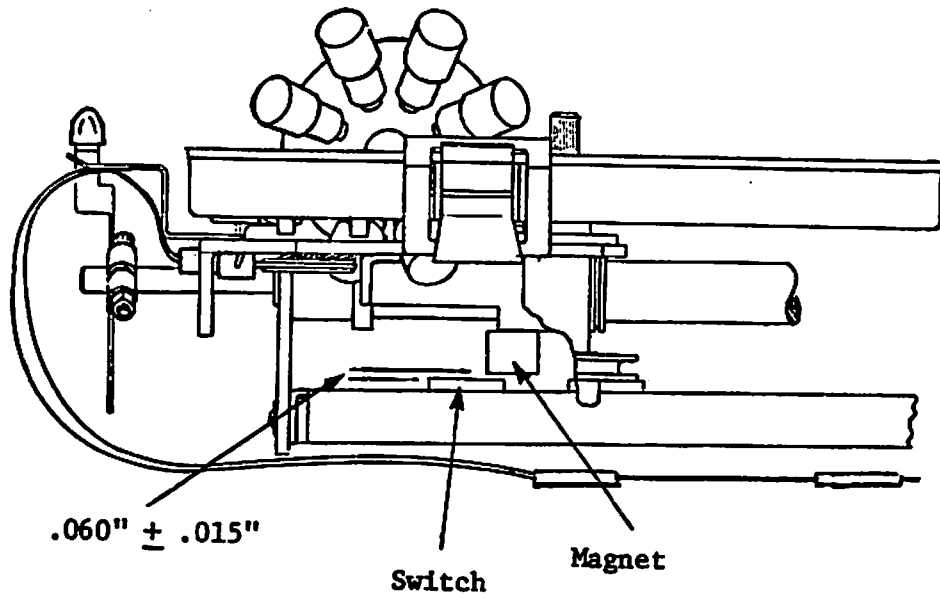

FIGURE 5-15 REED SWITCH MAGNET

- 2) A carriage return should occur automatically after a full buffer condition (112 characters) is generated. This can be accomplished by sending a line of more than 112 characters from the the CPU, or by plugging in the printer exerciser.
- 3) WITH POWER OFF, a gap of $.060'' \pm .015''$ (.152 cm \pm .038 cm) should exist between the reed switch packages and the reed switch magnet.

NOTE:

SW₃ on the 2231W-3 is adjusted to provide a full line of plotted dots without bumping into the frame.

5.3.7.2 Adjustment

WARNING:

Because the screwdriver used may be magnetic, always adjust the reed switches with power off. The accidental closing of these switches could be hazardous.

- 1) Adjust the switches by loosening the screws holding the reed switch brackets and use the previous adjustment checks in paragraph 5.3.7.1.
During the adjustment check if a reed switch appears to be faulty or misadjusted, shut off the power. Pull the reed switch fingerboard, 7063, from the electronic chassis. Proceed to check the defective reed switch by using an ohmmeter for continuity while moving the carriage magnet over the suspected switch or switches. The black lead on the fingerboard is common to all 3 switches. The color code for each switch is as follows:

SW0 (GREEN), SW1 (VIOLET) and SW2 (WHITE).

- 2) Loosen the four screws holding the reed switch bracket to side frames and move assembly up or down to adjust for $.060'' \pm .015''$ ($.152 \text{ cm} \pm .038 \text{ cm}$) gap between magnet and reed switch packages (Figure 5-15).
- 3) To adjust slot direction of the magnet, loosen the screw in the center of the magnet, turn the magnet to desired position and retighten screw.

5.3.7.3 Removal and Replacement

Reed Switch

- 1) Remove screws holding switch package.
- 2) Remove the wires from the solder lugs.
- 3) When replacing the switch, do not overheat the lugs and damage the switch.
- 4) Readjust the switch location (Section 5.3.7.2).

Mounting Bracket

- 1) Remove 7063 fingerboard from the electronic chassis.
- 2) Remove four screws holding the reed switch bracket to side frames and lift out.

5.3.8 Reed Switch Magnet (Figure 5-15)

5.3.8.1 Adjustment Check

Looking from the side of the carriage, the magnet should be centrally located over the reed switches, and the slot of the magnet should face in the direction of carriage motion.

5.3.8.2 Adjustment

See Removal and Replacement Procedure.

5.3.8.3 Removal and Replacement

- 1) Remove carriage assembly (Section 5.3.15).
- 2) Remove screw in center of magnet.
- 3) Reverse procedure to reassemble.
- 4) Readjust carriage belt tension, head adjustment arm, and striker plate (Section 5.3.2 to 5.3.4).

5.3.9 Magnetic Reluctance Pickup and Timing Disk

5.3.9.1 Adjustment Check

- 1) Place adjustment lug through pivot plate hole (Figure 5-16) and into timing disk hole. Check for a distance of $1.18'' \pm .01''$ ($3 \text{ cm} \pm .025 \text{ cm}$) between carriage assembly and left side frame.

- 2) Magnetic pickups and timing disk should not contact one another.
- 3) The distance between the edge/face of the timing disk and the pickkups should be consistent along the circumference of the disk with a gap of $.005'' \pm .001''$ ($.127 \text{ mm} \pm .025 \text{ mm}$) (Figure 5-17).

5.3.9.2 Adjustment

- 1) Loosen timing disk set screw; place adjustment plug through pivot plate hole and into timing disk hole.
- 2) Move carriage $1.18'' \pm .01''$ ($3 \text{ cm} \pm .025 \text{ cm}$) from left side frame (Figure 5-16, 17) and tighten timing disk set screw.
- 3) Loosen the index hole magnetic reluctance pickup locking nut.
- 4) Back out the pickup and place $.005''$ ($.127 \text{ mm}$) gauge between pickup and timing disk. Turn pickup in until i just contacts gauge and retighten locking nut.

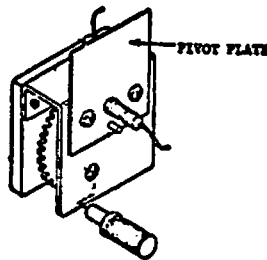

FIGURE 5-16 FIRST CHARACTER POSITION ADJUSTMENT

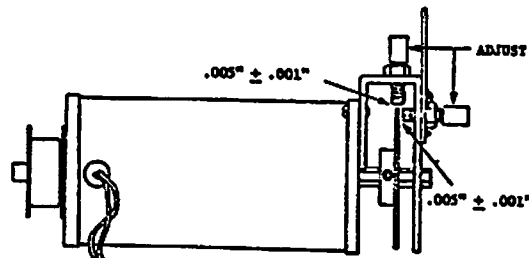

FIGURE 5-17 MAGNETIC PICKUP ADJUSTMENT

5.3.9.3 Removal and Replacement

- 1) Unsolder magnetic reluctance pickup wires from fingerboard.
- 2) Loosen pickup locking nut and unscrew pickups.
- 3) Reverse procedure to reassemble.

5.3.10 Paper Feed Sprockets and Paper Guide Cover

NOTE:

See Section 8 Figures 8-5 and 8-6.

5.3.10.1 Adjustment Check

- 1) With each of the sprocket wheel covers closed, there should be a gap between cover and paper-feed sprocket of .025" to .039" (.64 mm to .76 mm). See Figure 5-18.
- 2) The teeth of the sprocket should be centrally located in the cover slot as shown in Figure 5-19.

5.3.10.2 Adjustment

- 1) Adjust cover height with locking stop screw. Move screw down until a .030" (.76 mm) gauge begins to pinch between cover and rubber of sprocket. See Figure 5-19
- 2) Adjust sprocket cover pivot screws (2) to center teeth. This must be done to both paper guide assembly covers. The pivot screws act as eccentrics to center the cover.

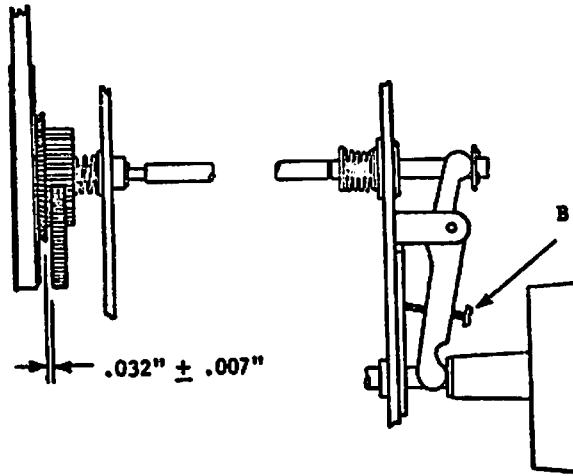

FIGURE 5-18 SPROCKET ADJUSTMENT
(DISENGAGED)

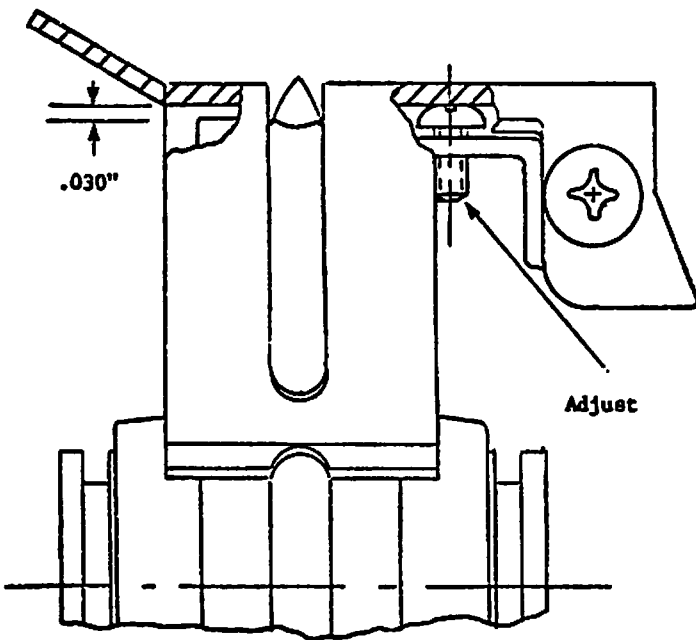

FIGURE 5-19 PAPER GUIDE COVER

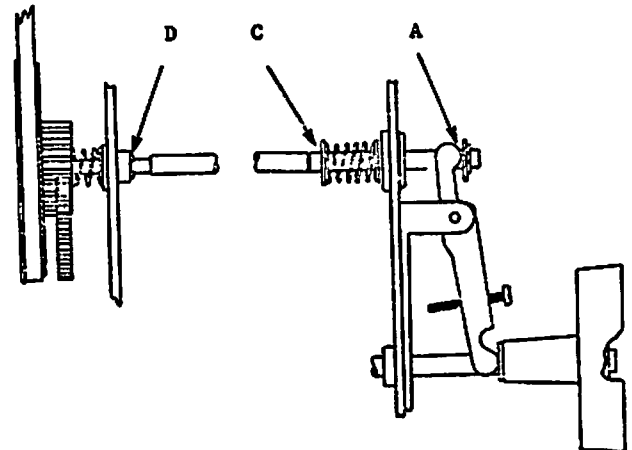

FIGURE 5-20 SPROCKET ADJUSTMENT
(ENGAGED)

5.3.10.3 Removal and Replacement

(Paper Feed Sprocket)

- 1) Remove horizontal vernier knob by removing allen screw from center of knob (Figure 5-20).
- 2) Remove snap ring and washer from the external right end of the vernier actuating rod.
- 3) Remove vernier actuating arm.
- 4) Remove the paper-drive-gear from left side of the paper-feed sprocket shaft and slide the paper-feed-sprocket springs and paper wheels off the splined shaft. See Figure 8-6 of Illustrated Parts List Section 8.
- 5) When removing and replacing the molded drive sprocket and rubber assembly (WL# 279-5070-63) for any reason, be sure that both the left and right sprocket teeth line up on the splined shaft. Each sprocket has a molded rib on the inside hub which is the key for proper alignment and proper paper drive. When reassembling the paper-feed-sprocket assembly, follow the steps in paragraph 5.3.10.3 in reverse, then check adjustments in Section 5.3.10.1.

(Paper Guide Cover)

- 1) Remove Phillips screws from ends of paper guide cover shaft. See Figure 8-6 of Section 8.
- 2) Remove shaft slipping paper-feed-sprocket slide-plates off paper-feed-sprockets.
- 3) Loosen plastic lock-screw and slide assembly off the shaft.

5.3.11 Horizontal Vernier Clutch (Paper Advance)

5.3.11.1 Adjustment Check

By using the horizontal vernier knob, push the vernier clutch in and out. With the use of a feeler gauge check for a clearance of $.032'' \pm .007''$ ($.081 \text{ cm} \pm .018 \text{ cm}$) between the idler gear and the cone gear as shown in Figure 5-18. Also when the knob is released after paper advancement the vernier clutch should fully re-engage flush with gear surface as shown in Figure 5-18. Also, when the knob is released after paper advancement, the vernier clutch should fully re-engage flush with gear surface as shown on Figure 5-20.

5.3.11.2 Adjustment

- 1) With clutch engaged (automatic advance) adjust allen screw in the center of horizontal vernier knob for a gap of $.021'' \pm .004''$ ($.053 \text{ cm} \pm .010 \text{ cm}$) between actuating arm and clutch rod washer (point A in Figure 5-20). (The screw can be adjusted through hole in horizontal vernier knob.)
- 2) With clutch disengaged (manual advance), adjust screw (B) for a $.032'' \pm .007''$ ($.081 \text{ cm} \pm .018 \text{ cm}$) gap between the cone gear and idler gear (Figure 5-18). (The screw can be adjusted through hole in horizontal vernier knob.)

5.3.11.3 Removal and Replacement

- 1) Remove allen screw in center of horizontal vernier knob and slide knob off shaft. See Figure 8-5 of Section 8 and Figure 5-20.
- 2) Remove snap ring and washer from the extreme right end of the vernier activating rod. See Figure 5-20.

- 3) Remove two screws on vernier actuating pivot bracket and remove bracket. See Figure 8-6 of Section 8.
- 4) Remove vertical format unit (Section 5.3.13).
- 5) Loosen paper-feed motor-mounting screws to release belt tension. See Figure 8-7 of Section 8.
- 6) Remove three mounting nuts from (VFU) format control plate and remove plate. See Figure 7 of Section
- 7) Remove snap rings, shaft spacers and two bushings from the vernier actuating rod and slide rod from the right to left out of the machine (Figure 5-20).
- 8) Remove snap ring from paper-drive-idler gear and then remove idler spur gear. See Figure 8-7 of Section 8.
- 9) To reassemble reverse procedure.
- 10) Check belt tension per Section (5.3.12.1).
- 11) Check all VFU adjustments per Section 5.3.13.

5.3.12 Paper Movement Gears

5.3.12.1 Adjustment Check

- 1) Check paper sprocket drive gear for maximum backlash of .030" (.076 cm), holding vertical format unit gear immobile (Figure 5-21).
- 2) Stepping Motor Timing Belt with the belt depressed .1" (.25 cm), the scale should read 1 lb (453 grams). (Figure 5-21.)

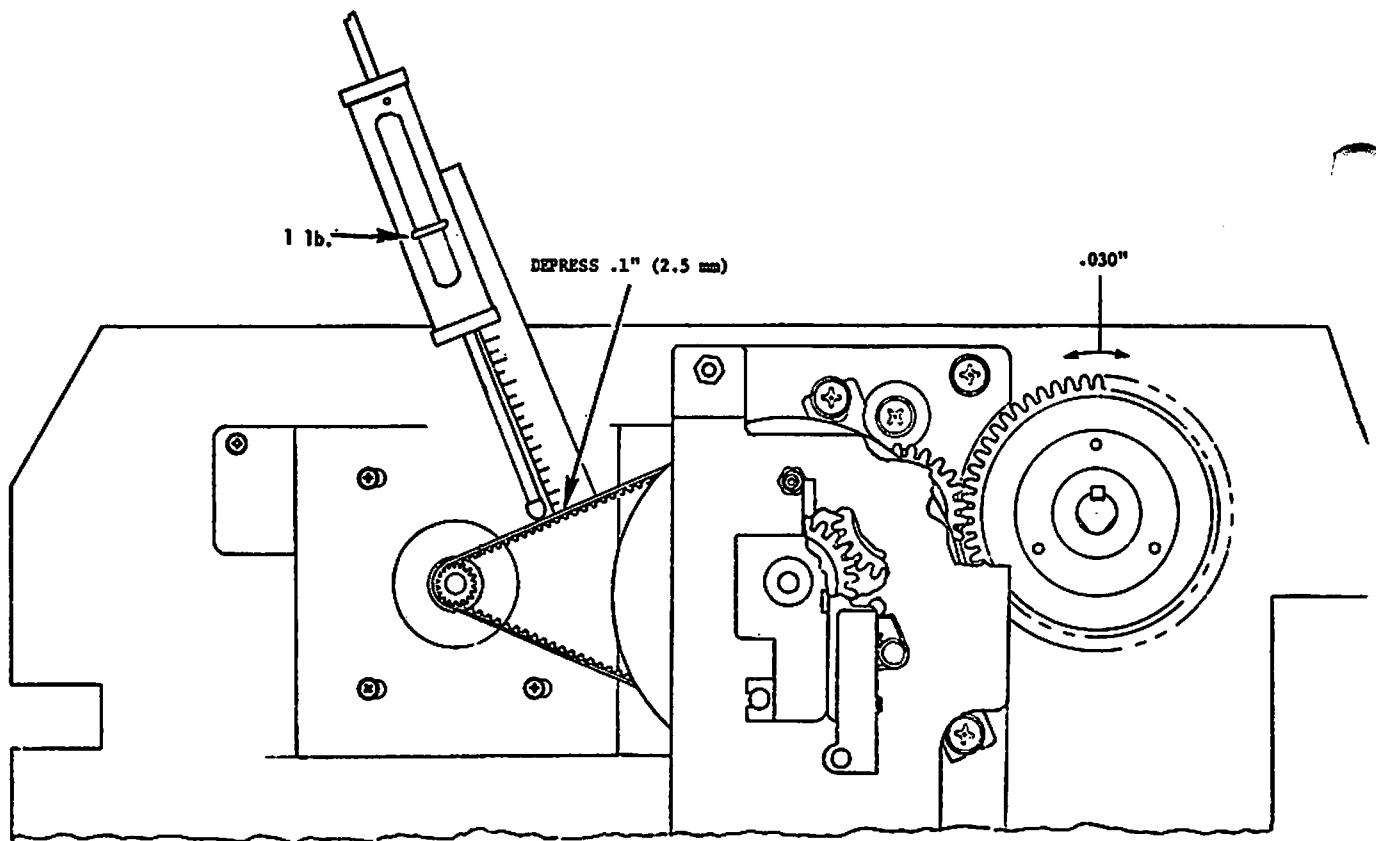

FIGURE 5-21 PAPER MOVEMENT ADJUSTMENT

5.3.12.2 Adjustments

- 1) Loosen the two idler-gear-mounting-screws to adjust gear train backlash.
- 2) Motor Belt - Loosen screws holding the motor bracket to the side frame. Move the motor in desired direction and tighten screws. Check VFU phasing adjustment (Section 5.3.13.1 step 4).

5.3.12.3 Removal and Replacement

(See Section 5.3.11.3 steps 1 to 11.)

5.3.13 Vertical Format Unit (VFU)

5.3.13.1 Adjustment Check

- 1) With the cover closed, there must be a $.012'' \pm .002''$ ($.31 \text{ mm} \pm .06 \text{ mm}$) uniform clearance between the cover and housing.
- 2) With the cover open and the tape well seated in the sprocket, the tape will be centered in the indented part of the housing.
- 3) The output of the phototransistor should be at least +4 volts on both channels of the VFU. Insert format tape in VFU and connect scope to the following pins of the 6761/6794 boards to determine their amplitude (hold the Top-Of-Form switch down continuously):

Channel 5 (VTS) M_3

Channel 7 (FFS) P_3

- 4) The stepping motor and VFU should be in phase. Connect a scope probe (channel 1) to pin M_3 of the 6761/6794 and another probe to L15 pin 8. Trigger on channel 1. Key Top-Of-Form continuously. Channel 1 of the scope is the output of channel 5 of the VFU and channel 2 of the scope is the 4th step signal (L15 pin 8) from the motor circuit. The 4 step pulse should appear just left of center of the VFU signal. See Figure 5-23A. If signals are incorrect proceed to Section 5.3.13.2 step 7.

5.3.13.2 Adjustment

- 1) The sprocket and housing are separate parts; hence with cover open, loosen the two screws holding the housing (Figure 5-22). Move the housing so that the base of the sprocket is flush with the housing.

- 2) Adjust cover stop eccentric to set a gap of $.012'' \pm .002''$ ($.31 \text{ mm} \pm .06 \text{ mm}$) between the cover and housing (Figure 5-22).
- 3) Connect scope probes to pins M_3 and P_3 of the 6761/6794 board.
- 4) With cover closed and no tape in format unit, loosen the three cover mounting screws and move the cover up or down until +5 volts from both channels is attained while maintaining the clearances specified between housing and cover.
- 5) Replace the format tape and close the cover. With probes attached as in Section 5.3.13.1, step 4, key Top-of-Form continuously. The signals should be at least +4 volts on each channel. If signals are less than +4 volts, then remove cell mount cover and adjust horizontal position of paper tape sprocket (see Section 5.3.13.3 step 6).

NOTE:

The following steps are purely for phase adjustment. Do not perform this adjustment unless absolutely necessary.

- 6) Follow 5.3.13.1 steps 3 and 4 to set up for this adjustment and to check phase. (Format tape is in VFU for this adjustment.)
- 7) If phase is off by more than a centimeter, a course alignment is necessary. Remove the belt between the stepping motor and timing gear (Horizontal Vernier Clutch Assembly) and rotate the Horizontal Vernier Clutch Assembly behind the VFU in desired direction several teeth and replace the belt. If the VFU signal is (channel 5) ahead of the 4th step pulse (Figure 5-23B), turn the Horizontal Vernier Clutch Assembly clockwise. If the 4th step pulse is ahead of the VFU signal (Figure 5-23C) then turn the Horizontal Vernier Clutch Assembly counterclockwise. If phase is off by a centimeter or less, loosening the motor retaining screws and then turning the motor in desired direction will correct phase error.

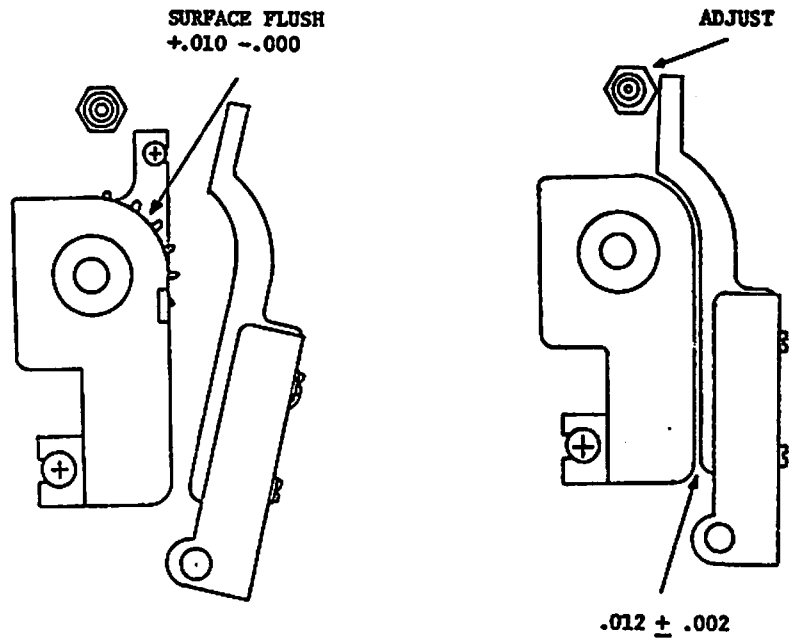

FIGURE 5-22 VERTICAL FORMAT HOUSING ADJUSTMENTS

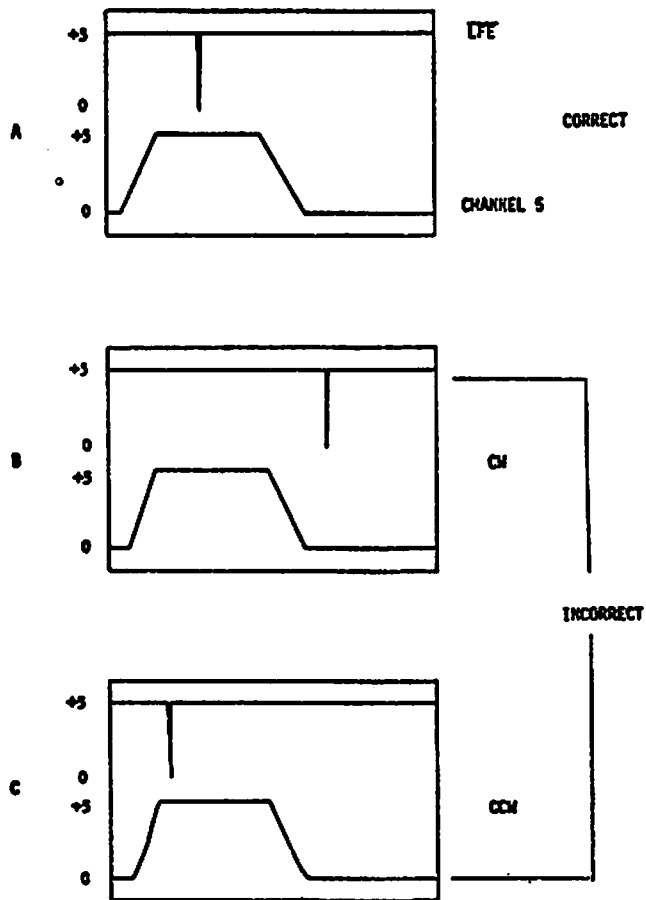

FIGURE 5-23 VFU AND STEPPER MOTOR PHASE CHECK

5.3.13.3 Removal and Replacement (Figure 5-24)

Removal

- 1) Remove format tape. Remove cell mount cover.
- 2) Turn horizontal vernier knob until paper-tape-sprocket allen screw is visible, then loosen allen screw.
- 3) Loosen VFU housing mounting screws and remove housing.

Replacement

- 4) Slide paper-tape-sprocket on vernier actuating rod.
- 5) Mount VFU housing and tighten mounting screws.
- 6) Rotate vernier actuating rod so flat surface is under paper tape sprocket allen screw and tighten allen screw. (Loosen allen screw to adjust horizontal position on shaft for required signal in Section 5.3.13.2 step 5.
- 7) Replace cell mount cover.
- 8) Check VFU adjustments (Section 5.3.13.1).

5.3.14 Carriage Servomotor Removal and Replacement

Removal and Replacement

- 1) Using 2-7/16" wrenches, remove main drive-belt pulley on left side of printer.
- 2) Remove 3-hex head screws holding servo to side plate assembly.
- 3) Unplug servo/magnetic pickup cable fingerboard and remove servo assembly.
- 4) Reverse procedure to reassemble.

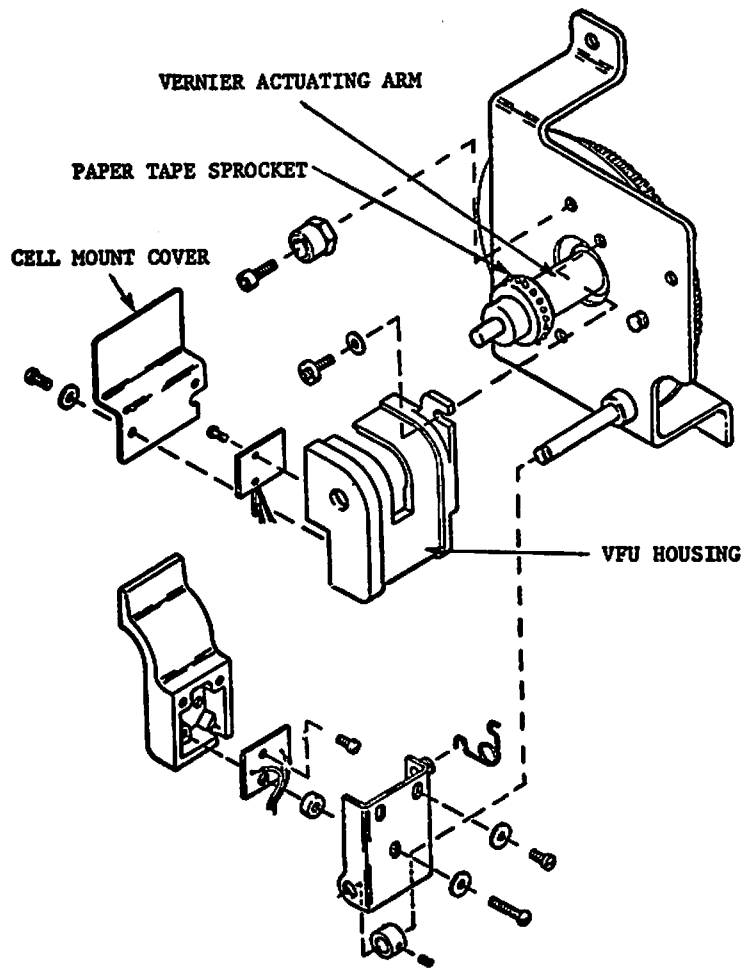

FIGURE 5-24 VERTICAL FORMAT UNIT

5.3.15 Carriage Assembly Removal and Replacement

- 1) Remove ribbon cartridge (see Section 3.2.1).
- 2) Remove head adjustment arm (Section 5.3.1.).
- 3) Using 2-7/16" wrenches, remove main drive-belt pulley from left side of printer.
- 4) Loosen allen set screws on right and left side of carriage shaft and remove shaft end pins.
- 5) Remove main carriage belt from servo drive gear.
- 6) Remove carriage stops on carriage shaft and slide carriage off the carriage shaft.
- 7) Reverse procedure to reassemble.
- 8) Readjust carriage belt tension and head adjustment arm (Section 5.3.2 to 5.3.4).

5.3.16 Electronic Assembly Cover Removal and Replacement

- 1) Loosen three screws on rear of electronic chassis.
- 2) Loosen two hex nuts on top of platen mounting bracket and slide cover back and lift out.
- 3) Reverse procedure to reassemble.

5.3.17 Cover Removal and Replacement

- 1) Loosen rear side frame mounting bracket hex screws on both sides of printer.

- 2) Rotate cover retainer clip backward.
- 3) Remove control panel fingerboard and remove ribbon cable from retaining clips.
- 4) Lift rear cover and slide out of slot.

1. The first part of the document is a list of names.

2. The second part of the document is a list of names.

3. The third part of the document is a list of names.

4. The fourth part of the document is a list of names.



SECTION 6
MAINTENANCE

6.1 INTRODUCTION

This section of the manual consists of three sections: diagnostics, preventive maintenance and troubleshooting for 2231W-1, -2 and -3.

The diagnostics section contains a description, operating procedure and a sample diagnostic program to be run on the Model 2231W Printer by the companion Model 2200 computer. The diagnostic program is written to aid the user in the checkout of equipment and to assure sustained quality of character printing.

The preventive maintenance section will amplify Section 5 (Adjustments, Removal and Replacement) by directing the user to the more frequent problems solved by inspection (visual checks) such as cleaning, wear, adjustments and lubrication.

Troubleshooting tables are available to aid in finding the cause and the solution to operating problems. The tables commence with the most common and basic faults and progress to the less frequent and more complex faults.

6.2 DIAGNOSTICS

The Model 2231W Matrix Printer uses a tape diagnostic program. The tape may be run through all tests for a complete checkout or individual tests may be chosen to perform only specific checks. This diagnostic can be used on all 3 machines however, a separate diagnostic must be used to check the 2231W-3 plot function.

6.2.1 2231W Diagnostic

1. Perform the following functions in order shown:

Key CLEAR EXECUTE

Key LOAD EXECUTE

Key RUN EXECUTE

2. The CRT will display the following readout:

Enter 0 for diagnostic, 1 for burn-in, 2 for operation check.

- a. 0 for diagnostic
Complete diagnostic checkout.
- b. 1 for burn-in
Prints regular and expanded characters for quality check.
- c. 2 for Operation check
Test 1 - Short checkout of keyboard and function codes.
Test 2 - Print quality and consistency in print pattern.
Test 3 - Repeated keyboard printout.
Test 4 - Vertical character alignment.
Test 5 - Repeated line feed.

6.2.2 Description of Command 2231W-1,-2,-3 Diagnostic

- 1) Complete printer test; includes all of the following test:
- 2) Data Buffer Test (Special Function #2) prints five lines each of the following:
 - A. Data Bits 1 through 6 (HEX (3F=?), 5 lines of ?
 - B. Data Bits 5 & 6 HEX (30=0), 5 lines of 0
 - C. Data Bits 1,3,5 & 6 HEX (35=5), 5 lines of 5
 - D. Data Bits 2,4,5 & 6 HEX (3A=;), 5 lines of ;

- E. Data Bits 5,6 & 7 HEX (70=p), 5 lines of p
- F. Data Bits 2,4 & 6 HEX (2A=*), 5 lines of *
- G. Data Bits 1,3,5 & 7 HEX (55=U), 5 lines of U

This test is useful for determining which bit is at fault when malselection faults occur.

- 3) Expanded Buffer Test; (Special Function #18) prints the same as the Data Buffer Test only in expanded characters providing the same useful function.
- 4) Head Solenoid Firing Test; (Special Function #3), prints a combination of expanded and regular characters to determine print quality.
- 5) Spiral Print Test; (Special Function #4), prints lines of characters starting with a line length of 5 and each line has one additional character until the last line which is a full line containing the full set of ASCII characters. This test is useful for alignment problems (reed switches etc.)
- 6) Expanded Spiral Print Test (Special Function #17), prints the same spiral print as S.F.4 except in expanded print.
- 7) Line Feed Test #1; (Special Function #9), prints 18 stars vertically spaced in a straight line. Good for troubleshooting index problems.
- 8) Line Feed Test #2 (Special Function #10), prints 3 reference lines vertically spaced down the page. These lines can be measured to assure accuracy of index function.
- 9) Carriage Return Test (Special Function #12), prints the following tests:
 - A. 5 lines of 82 characters (return by HEX OD)
 - B. 5 lines of 132 characters (return by Hardware C/R)
 - C. 5 lines over 132 characters (return by Line/over/run)

- 10) Printable HEX Codes (Special Function #6), prints a full line of each HEX code and gives the code used. (112 characters set codes - 10 to 7E)
- 11) Expanded Printable HEX Codes; (Special Function #18), prints the same Hex codes as above in expanded print.
- 12) Special Pattern Test (Special Function #7), prints groups of 5 letters in a special pattern to indicate print quality. This test is useful in spotting intermittent malselection.

6.2.3 Looping Diagnostics For Scoping

When any function is suspected as being faulty, the diagnostic portion for that function should be used. For example; if line feed problems exist, the Line Feed Test #1 should be used. This test constantly loops, thereby providing a constant line feed. If any malfunction is observed, troubleshooting is greatly aided by simply scoping the line feed circuit from the line feed solenoid back to where the proper signal is observed, thereby pin pointing the defective component.

1. THIS IS THE FIRST LINE OF THE PRINT OUT

6. THIS IS THE SIXTH LINE.
7. VERTICAL TAB STARTS FROM THIS LINE.

12. VERTICAL TAB. HEX(0D)

6.2.4 2231W-3 Printer Diagnostic

The 2231W-3 Diagnostic comes on tape or disc. When loaded into a 2200, the Master Menu appears. These functions are sufficient for evaluating the condition of the machine. For troubleshooting, special function #16 gives the menu for troubleshooting tests.

6.2.5 Overall System Tests

2231W-3 Printer Diagnostic
Master Menu
Special Function Key Designation

1	Complete Printer Test	5	Paper Motion Test
2	Data Buffer Test	6	Normal Hex Code Test
3	Head Solenoid Test	7	Special Pattern Test
4	Spiral Pattern Test	8	Graphic Output Test
		16	Printer Sub Test Menu

6.2.5.1 Menu for Troubleshooting Tests

Special Function Key Designation

9	Line Feed Test No. 1	15	Repetitive Chart Output
10	Line Feed Test No. 2	16	Alternating Bit Pattern
11	Vertical Tab Test	17	Expanded Spiral Pattern
12	Carriage Return Test	18	Expanded Hex Code
13	Pin Selection Test	19	Operator Action Tests
14	Diagonal Line Test	31	Return To Master Menu

The 2231W-3 has its own Diagnostic Test, available either on tape or diskette.

6.3 PREVENTIVE MAINTENANCE

6.3.1 (QUARTERLY) LUBRICATION

Print Head lubrication is a requirement to reduce print wire breakage.

NOTE:

Lubricant can be ordered using Wang Part #6600180.

Remove the print head cover. Remove the sponge from the print wires and soak it with the lubricant. Press the sponge against the rear of the print bearing. This forces some of the lubricant into the bearing holes. Replace sponge and print head cover.

Immediately after lubricating, exercise the print head for several minutes so that each solenoid is used. This allows the lubricant to make contact with all surfaces of the bearing.

6.4 TROUBLESHOOTING

6.4.1 TROUBLESHOOTING HINTS

TABLE 6-1

SYMPTOM	CAUSE	SOLUTION
1. Power turn on and no lights.	1A. Power fuse blown. 1B. +5V low. 1C. No voltage. 1D. Q1 (heat sink) bad. No +5V to logic.	1A. Replace power fuse. 1B. Check and adjust +5V. 1C. Replace 6756. 1D. Replace Q1.
2. Power turn on and alarm light	2A. Servo fuse open. 2B. Servo fuse blows repeatedly.	2A. Replace servo fuse. 2B. Adjust SW0 and SW1 as per Section 5.3.7 and 5.3.8.
3. Print is inverted.	3A. 6758 Fingerboard reversed. 3B. 6759 Fingerboard reversed.	3A. Reverse 6758. 3B. Reverse 6759.
4. Power prime and carriage does not return to left margin.	4A. Check servo fuse. 4B. Check for paper jam in paper guide preventing carriage from returning. 4C. Main drive belt and pulleys binding.	4A. Replace fuse. 4B. Remove paper. Check paper guides for alignment and tension. 4C. Check adjustments as per Section 5.3.4.
5. Power on; depress select button and select lamp does not come on.	5A. Defective lamp. 5B. Replace switch. 5C. Defective connection to switch. 5D. Defective 7060.	5A. Replace lamp. 5B. Defective switch. 5C. Continuity check. 5D. Replace 7060.

NOTE:

Use the same procedure for checking Top of Form, clear and linefeed switches. (These switches are connected to 6761 PC board.)

SYMPTOM	CAUSE	SOLUTION
6. Front cover is open; CPU tells printer to print but no carriage movement.	6A. Cover open switch is on.	6A. Manually pull switch to closed position.
7. Front cover is closed; CPU tells printer to print but no carriage movement.	7A. Cover open switch wired wrong. 7B. Cover open switch defective. 7C. Defective 6761.	7A. Check wiring. 7B. Replace switch. 7C. Replace 6761/6794.
8. Erratic forward motion of carriage during printing.	8A. Defective servo circuit. 8B. Defective servo.	8A. Replace 6756 or 6761/6794. 8B. Replace servo motor.
9. Carriage assembly returning at slow speed after printing a line.	9A. SW1 reed switch defective (shorted). 9B. 6761/6794 PCB defective.	9A. Replace reed switch 9B. Replace 6761/6794.
10. Carriage return fast with no deceleration.	10A. Defective 6761/6794. 10B. SW1 appears defective. (Open)	10A. Replace 6761/6794. 10B. Replace SW1 or align magnet.
11. No power to servo drive mechanism, but power lights on.	11A. Servo fuse open. 11B. Bad connection. 11C. +5V logic not up.	11A. Replace fuse. 11B. Check seating of pins and connectors. 11C. Adjust +5V logic.
12. No printing, but carriage movement.	12A. No WS signal. 12B. Defective magnetic pickup. 12C. Timing on 6761/6794.	12A. Check magnetic pickup signal. 12B. Replace magnetic pickup. 12C. Adjust 50% duty cycle on 6761/6794. or replace 6761/6794.
13. No delays between manual line feeds.	13A. 6761/6794 (L77) defective.	13A. Replace 6761/6794 (or L7).
14. No line feeds except under program control.	14A. Defective line feed switch. 14B. Defective 6761/6794.	14A. Replace switch. 14B. Replace 6761/6794.

SYMPTOM

CAUSE

SOLUTION

- | | | |
|--|---|---|
| <p>15. Continuous paper feed when top of form executed.</p> | <p>15A. Defective 6761.
15B. VFU defective.</p> <p>15C. No VFU tape.</p> | <p>15A. Replace 6761.
15B1. Adjust VFU
15B2. Replace paper tape.
15B3. Replace LED.
15B4. Replace photocell.
15C. Install tape.</p> |
| <p>16. Poor print quality at one specific location.</p> | <p>16A. Burr on chassis.</p> <p>16B. Defective timing disk.</p> | <p>16A. Check carriage bearing guide shaft or plate for dirt or burrs at that location.
16B. Replace timing disk.</p> |
| <p>17. Poor print quality everywhere (characters not symmetrical).</p> | <p>17A. Timing 6761.
17B. Magnetic pickup.
17C. Head penetration.
17D. Solenoids in head maladjusted.
17E. Print head loose.</p> | <p>17A. Adjust 50% duty cycle 6761.
17B. Replace magnetic pickup.
17C. Adjust head penetration.
17D. Remove head assembly and adjust print head to specification.
17E. Tighten head.</p> |
| <p>18. Missing dots in character</p> | <p>18A. Defective ROM on 7060.
18B. Defective pwr. transistor on 6756.
18C. Maladjusted solenoid.
18D. Broken solenoid wire.
18D. Replace solenoid.</p> | <p>18A. Replace ROM in 7060.
18B. Replace transistor on 6756.
18C. Adjust solenoid.</p> |
| <p>19. Print head catching ribbon during printing.</p> | <p>19A. Head penetration exceeds .000".
19B. Ribbon worn out with too much head penetration.
19C. Solenoid staying in fixed position.
19D. Strobe too long.</p> | <p>19A. Adjust penetration.
19B. Replace ribbon and adjust penetration.
19C1. Replace solenoid.
19C2. Replace pwr. transistor on 6756.
19C3. Replace 7060.
19D. Adjust strobe length.</p> |
| <p>20. Print quality light on one side.</p> | <p>20A. Striker bar maladjusted.</p> | <p>20A. Adjust striker bar.</p> |

SYMPTOM	CAUSE	SOLUTION
21. Paper streaked during print.	21A. Head penetration to close.	21A. Increase head to striker bar gap.
	21B. Paper not within usable specs.	21B. Advise user to replace with paper meeting specifications.
	21C. Print solenoid dragging on paper.	21C. Adjust solenoid.
	21D. Ribbon cartridge guides maladjusted.	21D. Adjust cartridge ribbon guides.
22. No printing, but carriage moves to right and fails to return. Servo fuse blows.	22A. Loss of WS strobe.	22A. Check adjustment of magnetic pickup A and wires.
	22B. Missing index pulse.	22B. Check adjustment of magnetic pickup B and wires.
	22C. Defective 6761/6794 PCB.	22C. Replace 6761/6794 PCB.

6.5 115 VAC/230 VAC CONVERSION

To convert the Model 61 Printer from 115 VAC to 230 VAC or vice versa, remove the cover from the on/off switch and fuse assembly and then unscrew the switch and fuse assembly from the chassis to uncover the 115/230 VAC selector switch. Move the switch to the proper setting and reassemble.

6.6 RECOMMENDED SPARE PARTS LIST

PART	2231W-1	2231W-2	2231W-3
Print Head			279-5060-59
Solenoid	279-5060-14	279-5060-14	279-5060-14
I/O Data Storage Board	210-7060	210-6760	210-6795
Timing and Format Control	210-6761	210-6761	210-6794
Regulator Driver	210-6756	210-6756	210-6756
Keyboard	210-6762	210-6762	210-6762
Reed Switch	325-2416	Same	Same
Servo Motor Fuse 8/10	360-10085B	Same	Same
Main Fuse	360-1016SB	Same	Same
Magnetic Pickup	360-1016SB	Same	Same
Fan Assembly	279-0226	Same	Same
Carriage Motor Assy	279-0226	Same	Same
Carriage Motor Assy	279-5060-16	Same	Same

6.7 PRINTER CABLES

220-0105-1	Printer I/O cable
220-3003	14 Conductor 40" flat cable assembly (control panel)
270-3061	Reed switch harness
270-3062	Format control harness
420-1017	Print head cable

[The page contains extremely faint and illegible text, likely bleed-through from the reverse side of the paper. The text is scattered across the page and cannot be transcribed accurately.]

**SECTION 7
SCHEMATICS**

DRAWING #	DESCRIPTION:
D6756	POWER TRANSISTOR
E6760	I/O CONTROL DATA STORAGE
E6761	TIMING & FORMAT CONTROL
E6794	TIMING & FORMAT CONTROL
E6795 (Sheet 1)	I/O DATA STORAGE & CHARACTER GENERATOR
E6795 (Sheet 2)	I/O DATA STORAGE & CHARACTER GENERATOR
E7060	DATA STORAGE, I/O CONTROL, & CHARACTER GENERATOR
D7157	MOTHERBOARD

1971-1972

1971-1972

1971-1972

1971-1972

1971-1972

1971-1972

1971-1972

1971-1972

1971-1972

1971-1972

1971-1972

1971-1972

1971-1972

1971-1972

1971-1972

1971-1972

1971-1972

1971-1972

1971-1972

1971-1972

1971-1972

1971-1972

1971-1972

1971-1972

1971-1972

THIS DOCUMENT IS THE PROPERTY OF WANG LABORATORIES, INC. AND SHALL NOT BE REPRODUCED OR COPIED, OR USED AS A BASIS FOR THE MANUFACTURE OR SALE OF APPARATUS OR DEVICES WITHOUT PERMISSION.

COMPONENT	W.L. No.
R1,2,9	330-3027
R2,10	330-4012
R3,11	330-4033
R4,12	330-4022
R5,13,20	330-3047
R6,14,44,47	
R7,5,56,59	336-0026
R2,6,5,60	
R2,15,8,9	330-3033
R8,16	330-5097
R9,13,80-88	330-3010
R20,22,90-97	330-2022
R21	330-2068
R23,24,38,50	330-2033
R24	336-1014
R25	330-3039
R26,27-79	330-2047
R17,34,35	330-3022
R30,31	330-2027
R32	330-0068
R33	330-1010
R45,48,51,58	
R28,63,66	330-2010
C9	
R46,49,52,55	331-1022
R8,46,66,70	
C4,2	300-4013
C3,4,5,9	300-4021
C6	300-1901
C7	300-1913
C8	300-1926
D1,4-17	380-4000
D2	380-2121
D3	380-2113
Q1	375-1054
Q2	375-1053
Q3	375-1052
Q4,6	375-1051
Q5,7	375-1050
Q8-16	375-1051
Q17,19,21	375-1017
Q3-8,9	
Q20,22	375-1006
Q20,32	375-1027
Q31,32	375-1026
H. SINR	375-9010
TRANS/IMP LARGE	375-9001
TRANS/IMP SMALL	375-9004
J1	350-0037

I.C. LOCATION	W.L. NO.	TERM. FOR 3OV	TERM. FOR VCC +5VR
L1	376-0066	5	
L2	376-0187		

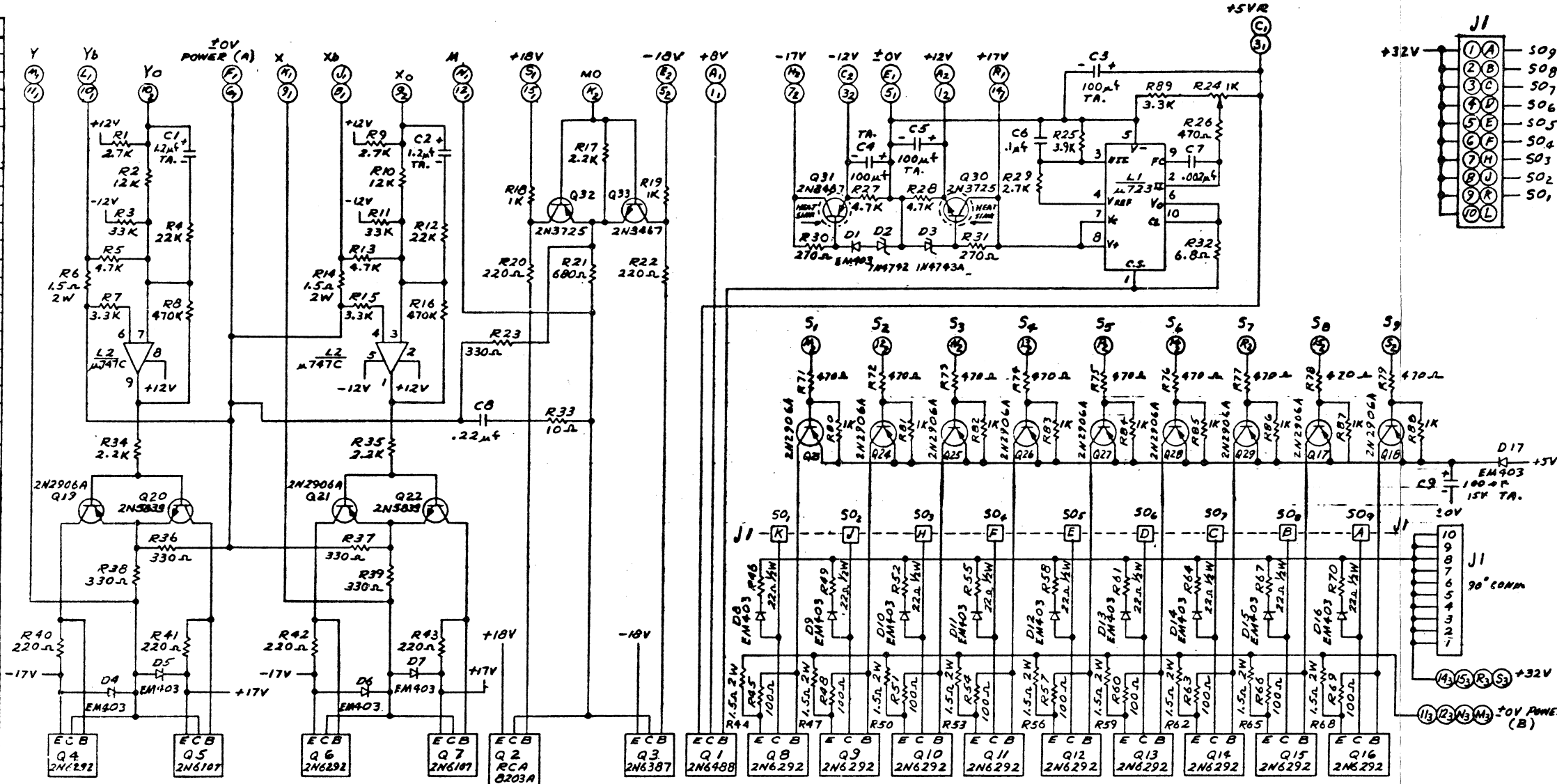

DRILLED OR PUNCH-HOLE	HOLE DIA.	TOL.
DRILLED	0.125 to 0.125	±.002
PUNCH-HOLE	0.125 to 0.250	±.002
TOLERANCE	0.251 to 0.500	±.005

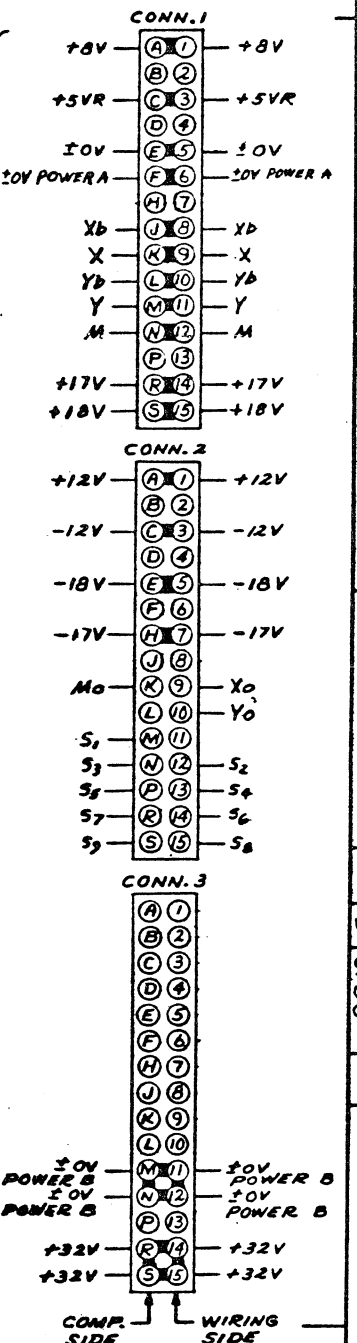

COMPONENT LAYOUT

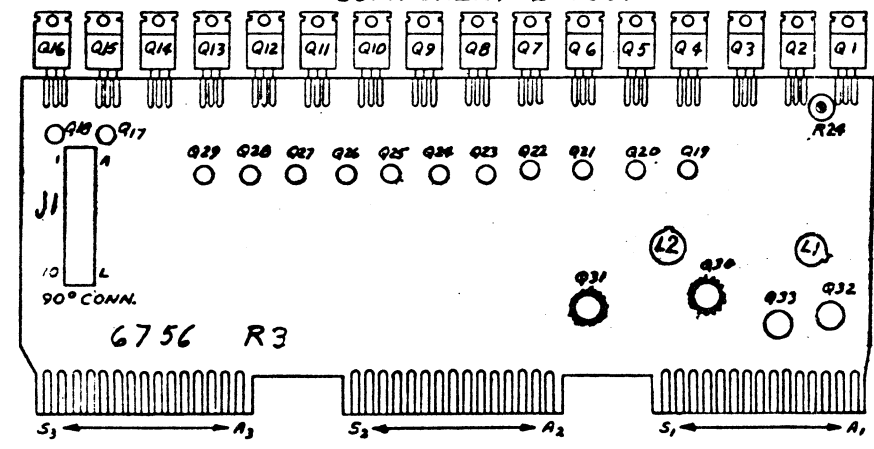

AUG 22 1978

E-REV 4

WANG PART NO.	ITEM	QTY	NAME	MATERIAL	DESCRIPTION
	FIRST USED ON				
	ASSY USED ON				
			WANG LABORATORIES, INC.		
			TELEPHONE: 617-552-4000		
			MODEL NO. 62 MATRIX PRINTER		
			SEE ENGR. SPECIFICATIONS		
			TOL. EX. AS NOTED		
			XX ± 0.10 FRAC. ± 1/64		
			XXX ± 0.05 ANG. ± 1°30' FINISH		
			SCALE: SHT 1 OF 7		
			TITLE: SCHEMATIC LOGIBLOC POWER TRANSISTOR BOARD		
			210-6756	D	6756 9
			WANG PART NUMBER	SIZE	DRAWING NUMBER

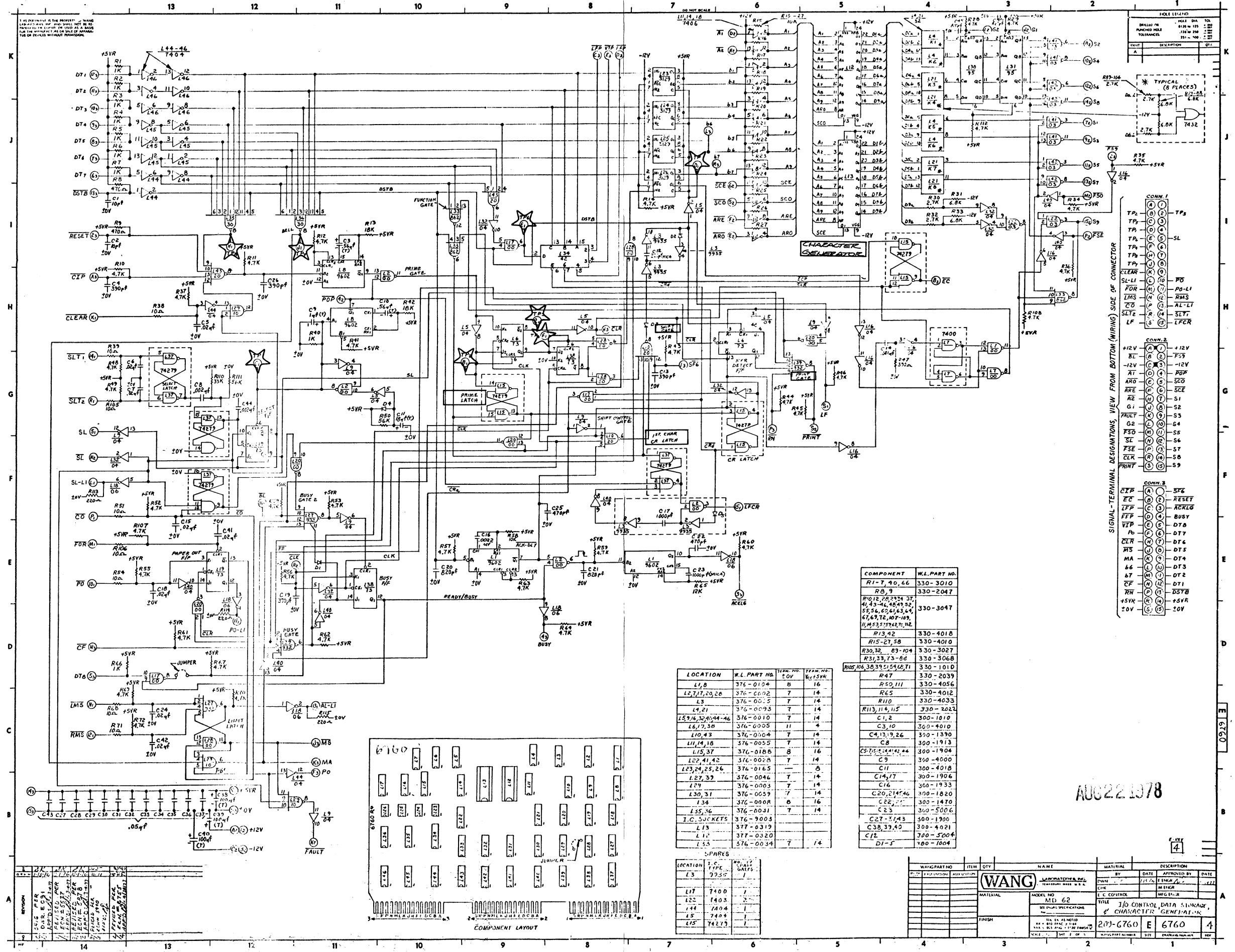

COMPONENT	M.L. PART NO.
R1-7, 40, 46	330-3010
R8, 9	330-2047
R10, 12, 26, 27, 34, 37, 41, 43-46, 48, 49, 52, 55, 56, 60, 61, 63, 64, 67, 68, 72, 107-109, 114, 153, 157, 162, 162	330-3047
R13, 42	330-4018
R15-27, 58	330-4010
R30, 32, 89-104	330-3027
R31, 33, 73-82	330-3068
R35, 106, 30, 39, 21, 54, 67, 1	330-1010
R47	330-2039
R50, 111	330-4056
R65	330-4012
R110	330-4033
R113, 114, 115	330-2022
C1, 2	300-1010
C3, 10	300-4010
C4, 13, 9, 26	300-1390
C8	300-1913
C5, 7, 14, 41, 42	300-1904
C9	300-4000
C11	300-4018
C14, 77	300-1906
C16	300-1933
C20, 21, 47, 46	300-1820
C22, 23	300-1470
C23	300-5006
C27-31, 43	300-1900
C38, 39, 40	300-4021
C12	300-5004
D1-5	700-1004

LOCATION	M.L. PART NO.	QTY	FRAM. NO.
L1, 8	376-0104	8	16
L2, 7, 17, 20, 28	376-0072	7	14
L3	376-0015	7	14
L4, 21	376-0093	7	14
L5, 9, 30, 40, 44-46	376-0010	7	14
L6, 19, 38	376-0005	11	4
L10, 43	376-0104	7	14
L11, 14, 18	376-0055	7	14
L15, 37	376-0186	8	16
L23, 41, 42	376-0028	7	14
L24, 25, 26	376-0165	7	14
L27, 39	376-0046	7	14
L29	376-0063	7	14
L30, 31	376-0057	7	14
L34	376-0008	8	16
L35, 36	376-0041	7	14
L.C. SOCKETS	376-9003		
L15	377-0319		
L11	377-0320		
L13	376-0034	7	14

LOCATION	I.C. TYPE	NO. OF GATES
L3	7400	1
L17	7400	2
L22	7403	2
L44	7404	1
L5	7404	1
L15	7427	1

AUG 22 1978

WARRANTY NO.	ITEM	QTY	NAME	MATERIAL	DESCRIPTION
WANG					
MODEL NO. 62					
TITLE: 110 CONTROL DATA LINKAGE & CHARACTER GENERATOR					
200-6760 E 6760 4					

REVISION	DATE	BY	DESCRIPTION
1			
2			
3			
4			
5			
6			
7			
8			
9			
10			
11			
12			
13			
14			

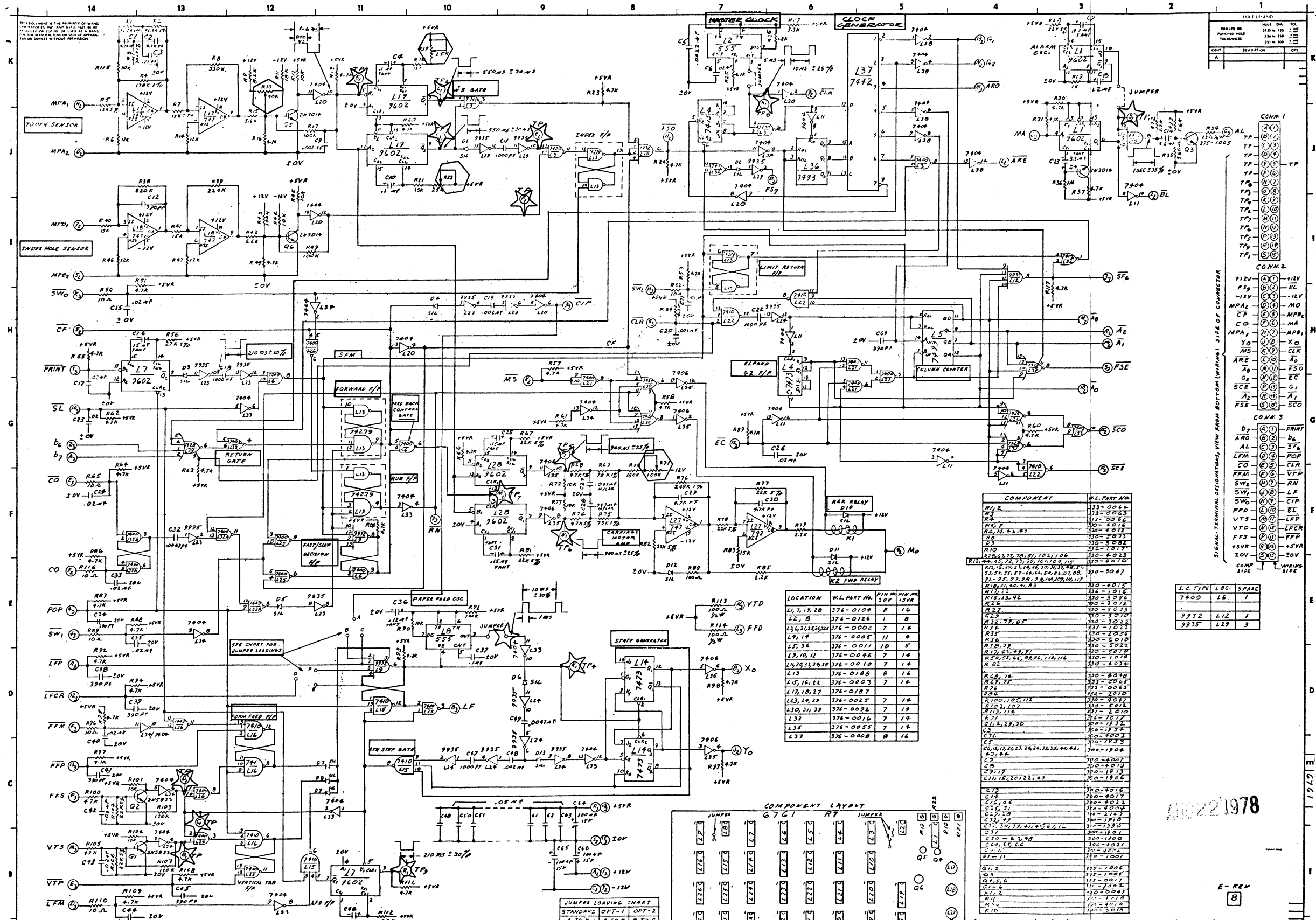

REV	DESCRIPTION	DATE
1	ISSUED FOR FAB	11-15-66
2	REVISED FOR	11-15-66
3	REVISED FOR	11-15-66
4	REVISED FOR	11-15-66
5	REVISED FOR	11-15-66
6	REVISED FOR	11-15-66
7	REVISED FOR	11-15-66
8	REVISED FOR	11-15-66
9	REVISED FOR	11-15-66
10	REVISED FOR	11-15-66
11	REVISED FOR	11-15-66
12	REVISED FOR	11-15-66
13	REVISED FOR	11-15-66
14	REVISED FOR	11-15-66

CONN 1

1	TP
2	TP
3	TP
4	TP
5	TP
6	TP
7	TP
8	TP
9	TP
10	TP
11	TP
12	TP
13	TP
14	TP

CONN 2

1	12V
2	12V
3	12V
4	12V
5	12V
6	12V
7	12V
8	12V
9	12V
10	12V
11	12V
12	12V
13	12V
14	12V

CONN 3

1	PRINT
2	AR0
3	AL
4	LPM
5	CO
6	FFM
7	SW
8	SWG
9	FFD
10	VTS
11	VTD
12	FFS
13	12V
14	20V

COMPONENT

LOCATION	W.L. PART NO.	QTY	DESCRIPTION
R1,2	330-0044	2	RES
R3	330-0044	1	RES
R4	330-0044	1	RES
R5,7	330-0044	2	RES
R6,14,16,17	330-0044	4	RES
R8	330-0044	1	RES
R9	330-0044	1	RES
R10	330-0044	1	RES
R11,12,13,15,18,19,20,10,11,12,13,15,18,19,20	330-0044	15	RES
R14,15,16,17,18,19,20,10,11,12,13,15,18,19,20	330-0044	15	RES
R21,22,23,24,25,26,27,28,29,30,31,32,33,34,35,36,37,38,39,40,41,42,43,44,45,46,47,48,49,50,51,52,53,54,55,56,57,58,59,60,61,62,63,64,65,66,67,68,69,70,71,72,73,74,75,76,77,78,79,80,81,82,83,84,85,86,87,88,89,90,91,92,93,94,95,96,97,98,99,100	330-0044	100	RES

LOCATION W.L. PART NO. QTY DESCRIPTION

L1,2,19,20	374-0104	8	16
L2,8	374-0124	1	8
L3,21,22,23,24	374-0002	7	16
L4,14	374-0005	11	4
L5,36	374-0011	10	5
L6,10,12	374-0046	7	16
L7,18,23,24,25	374-0010	7	16
L8,13	374-0185	8	16
L9,16,22	374-0003	7	16
L10,18,27	374-0015	7	16
L12,16,29	374-0187	7	16
L13,31,39	374-0032	7	16
L32	374-0016	7	16
L35	374-0005	7	16
L37	374-0008	8	16

I.C. TYPE LOC. SPACE

7400	L6	1
7401	L2	1
7402	L23	3

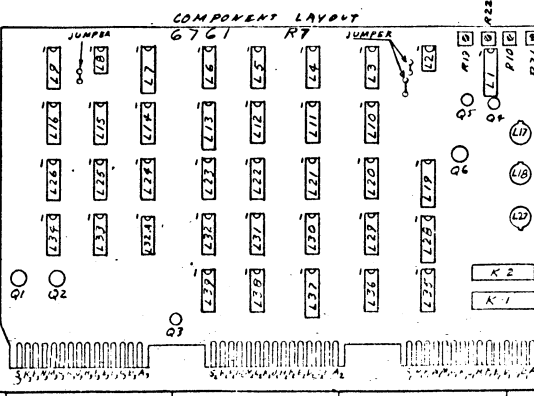

REV	DESCRIPTION	DATE
1	ISSUED FOR FAB	11-15-66
2	REVISED FOR	11-15-66
3	REVISED FOR	11-15-66
4	REVISED FOR	11-15-66
5	REVISED FOR	11-15-66
6	REVISED FOR	11-15-66
7	REVISED FOR	11-15-66
8	REVISED FOR	11-15-66
9	REVISED FOR	11-15-66
10	REVISED FOR	11-15-66
11	REVISED FOR	11-15-66
12	REVISED FOR	11-15-66
13	REVISED FOR	11-15-66
14	REVISED FOR	11-15-66

CHANGE IN PROCESS
 PER 1001 9016
 DATE: 1001 1970

WANG PARTS

ITEM	QTY	NAME	MATERIAL	DESCRIPTION
1	1	WANG
2	1	WANG
3	1	WANG
4	1	WANG
5	1	WANG
6	1	WANG
7	1	WANG
8	1	WANG
9	1	WANG
10	1	WANG
11	1	WANG
12	1	WANG
13	1	WANG
14	1	WANG

AUG 22 1978

E-REV
8

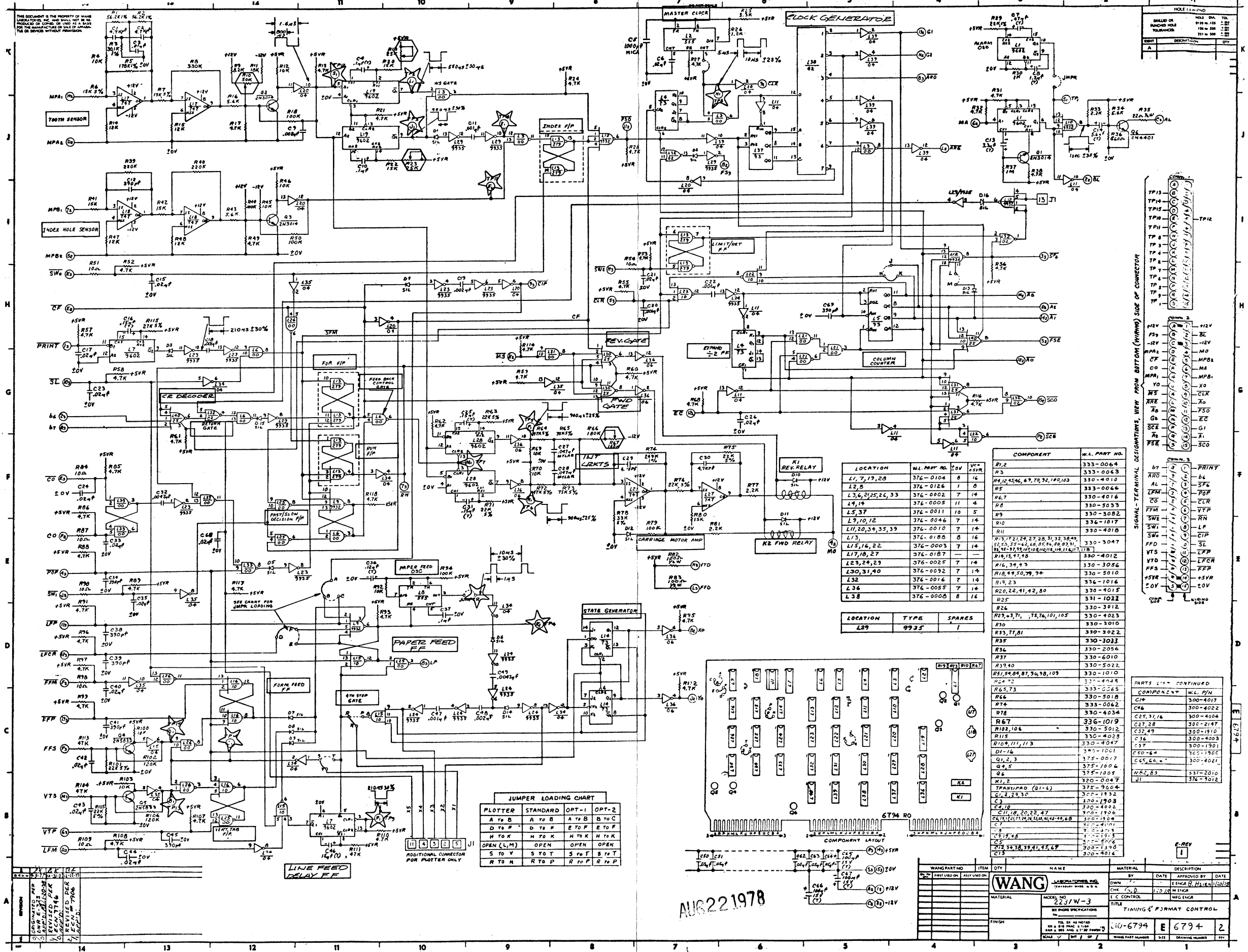

REV	DESCRIPTION	DATE
1	INITIAL	
2	REVISED	
3	REVISED	
4	REVISED	

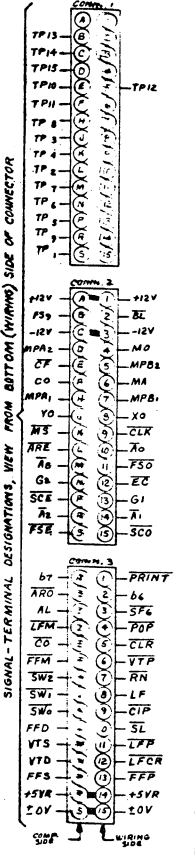

LOCATION	W.L. PART NO.	QTY	W.C. PART NO.
R12	333-0064		
R3	333-0063		
L1, 7, 19, 20	376-0104	8	16
L2, 8	376-0126	1	8
L3, 6, 25, 26, 33	376-0002	7	14
L4, 19	376-0005	11	4
L5, 37	376-0011	10	5
L9, 10, 12	376-0046	7	14
L11, 20, 34, 35, 39	376-0010	7	14
L13	376-0188	8	16
L15, 16, 27	376-0003	7	14
L17, 18, 22	376-0187		
L23, 24, 23	376-0025	7	14
L30, 31, 40	376-0092	7	14
L32	376-0016	7	14
L36	376-0055	7	14
L38	376-0008	8	16

LOCATION	TYPE	SPARES
L29	9935	1

COMPONENT	W.L. PART NO.
R12	333-0064
R3	333-0063
R4, 10, 45, 46, 67, 70, 72, 100, 103	330-4010
R5	333-0066
R6, 7	330-4016
R8	330-5033
R9	330-3082
R10	336-1017
R11	330-4010
R13	376-0188
R15, 16, 27	376-0003
R17, 18, 22	376-0187
R23, 24, 23	376-0025
R30, 31, 40	376-0092
R32	376-0016
R36	376-0055
R38	376-0008
R25	331-1022
R26	330-3812
R27, 37, 1, 75, 76, 101, 105	330-4023
R30	330-3010
R33, 77, 81	330-3022
R35	330-3033
R36	330-2056
R37	330-6010
R39, 40	330-5022
R51, 54, 84, 87, 94, 108, 109	330-1010
R52, 73	330-4049
R65, 73	330-5065
R66	330-5018
R74	330-4022
R78	330-4034
R67	336-1019
R102, 104	330-5012
R115	330-4028
R109, 111, 113	330-4047
D1-16	375-0017
C1, 2, 3	375-1006
C4, 5	375-1005
C6	375-1005
K1, 2	320-0047
TRANSIPAD (Q1-L)	375-9004
C1, 2, 23, 30	375-1932
C3	375-1903
C10	375-1906
C11, 18, 20, 22, 47	375-1906
C5, 17, 21, 24, 26, 28, 42, 43, 48	375-1904
C7	375-1904
C8	375-1904
C9	375-1904
C12, 19, 25, 27	375-1904
C13	375-1904
C14	375-1904
C15	375-1904
C16	375-1904
C17	375-1904
C18	375-1904
C20	375-1904
C21	375-1904
C22	375-1904
C24	375-1904
C25	375-1904
C26	375-1904
C27	375-1904
C28	375-1904
C29	375-1904
C31	375-1904
C32	375-1904
C33	375-1904
C34	375-1904
C35	375-1904
C36	375-1904
C37	375-1904
C38	375-1904
C39	375-1904
C40	375-1904
C41	375-1904
C42	375-1904
C43	375-1904
C44	375-1904
C45	375-1904
C46	375-1904
C47	375-1904
C48	375-1904
C49	375-1904
C50	375-1904
C51	375-1904
C52	375-1904
C53	375-1904
C54	375-1904
C55	375-1904
C56	375-1904
C57	375-1904
C58	375-1904
C59	375-1904
C60	375-1904
C61	375-1904
C62	375-1904
C63	375-1904
C64	375-1904
C65	375-1904
C66	375-1904
C67	375-1904
C68	375-1904
C69	375-1904
C70	375-1904
C71	375-1904
C72	375-1904
C73	375-1904
C74	375-1904
C75	375-1904
C76	375-1904
C77	375-1904
C78	375-1904
C79	375-1904
C80	375-1904
C81	375-1904
C82	375-1904
C83	375-1904
C84	375-1904
C85	375-1904
C86	375-1904
C87	375-1904
C88	375-1904
C89	375-1904
C90	375-1904
C91	375-1904
C92	375-1904
C93	375-1904
C94	375-1904
C95	375-1904
C96	375-1904
C97	375-1904
C98	375-1904
C99	375-1904
C100	375-1904

COMPONENT	W.L. PART NO.
C104	330-4019
C46	330-4022
C27, 31, 16	330-4004
C27, 28	330-2147
C32, 49	330-1912
C36	330-4003
C37	330-1901
C50-64	375-1902
C65, 66	330-4021
R42, 83	337-2010
U1	376-3012

JUMPER LOADING CHART

	STANDARD	OPT-1	OPT-2
A to B	A to B	A to B	B to C
D to F	D to F	E to F	E to F
H to K	H to K	H to K	H to K
OPEN (L, M)	OPEN	OPEN	OPEN
S to V	S to T	S to T	S to T
R to N	R to P	R to P	R to P

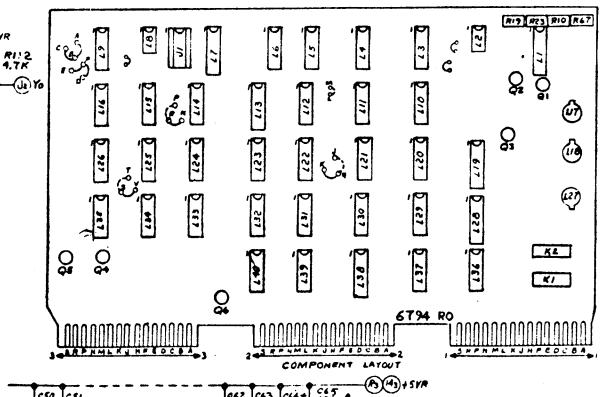

AUG 22 1978

WANG PART NO.	ITEM	QTY	NAME	MATERIAL	DESCRIPTION	DATE
6794	1	1	Timing & Format Control			

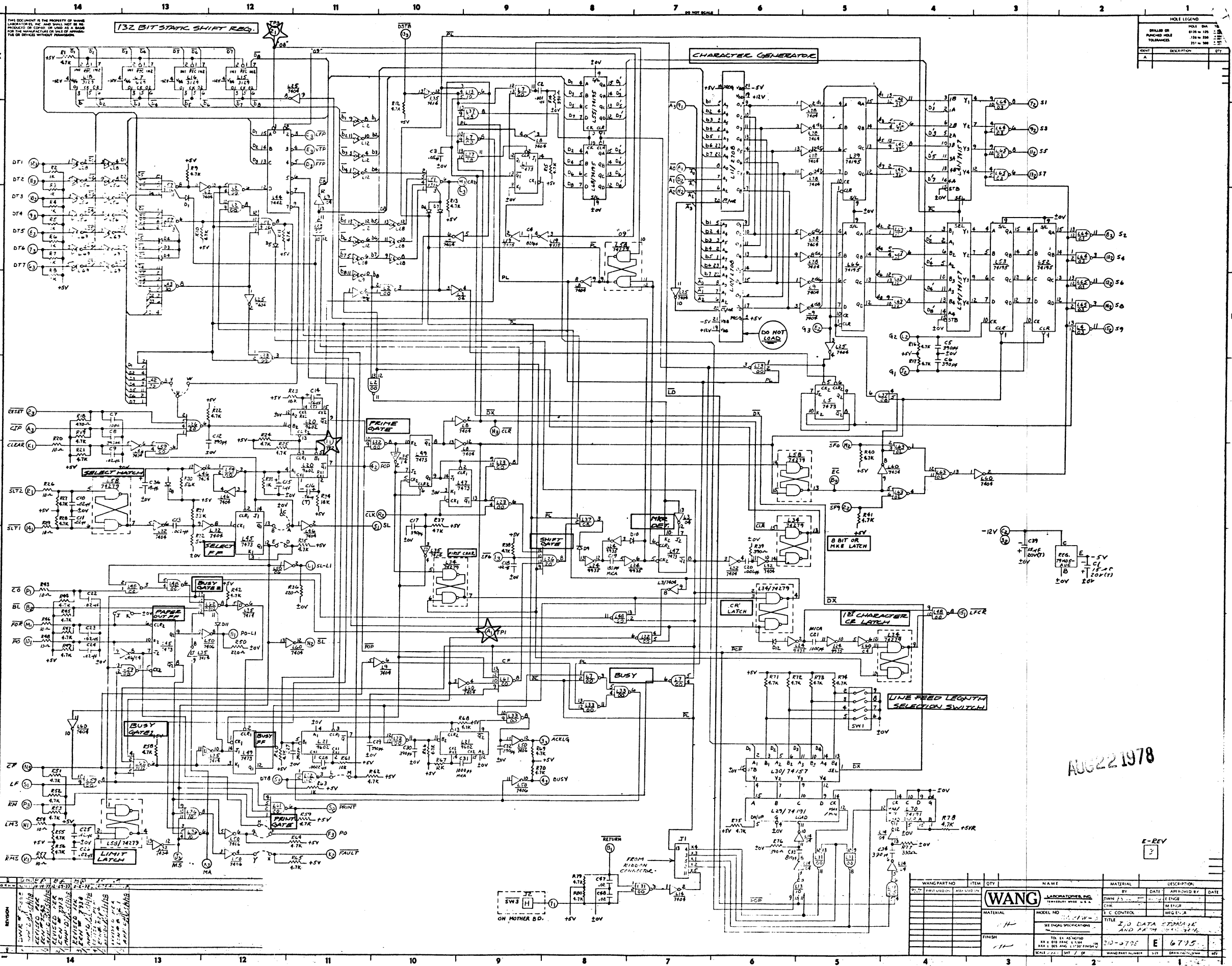

THIS DOCUMENT IS THE PROPERTY OF WANG
LABORATORIES, INC. AND SHALL NOT BE
REPRODUCED OR COPIED IN ANY MANNER
FOR THE MANUFACTURE OF OTHER DEVICES
WITHOUT PERMISSION.

132 BIT STATIC SHIFT REG.

CHARACTER GENERATOR

HOLE LEGEND

SIZE	DESCRIPTION	QTY.
1/16	316 IN DIA	10
1/8	316 IN DIA	20
3/16	316 IN DIA	20
1/2	316 IN DIA	10

REVISION

REV	DATE	DESCRIPTION
1	8/22/78	INITIAL DESIGN
2	8/22/78	REVISION 1A
3	8/22/78	REVISION 1B
4	8/22/78	REVISION 1C
5	8/22/78	REVISION 1D
6	8/22/78	REVISION 1E
7	8/22/78	REVISION 1F
8	8/22/78	REVISION 1G
9	8/22/78	REVISION 1H
10	8/22/78	REVISION 1I
11	8/22/78	REVISION 1J
12	8/22/78	REVISION 1K
13	8/22/78	REVISION 1L
14	8/22/78	REVISION 1M

WANG LABORATORIES, INC.

WANG PART NO.	ITEM	QTY.	NAME	MATERIAL	DESCRIPTION
7404	IC	10	7404	IC	7404
7401	IC	5	7401	IC	7401
7410	IC	2	7410	IC	7410
7411	IC	2	7411	IC	7411
7412	IC	2	7412	IC	7412
7413	IC	2	7413	IC	7413
7414	IC	2	7414	IC	7414
7415	IC	2	7415	IC	7415
7416	IC	2	7416	IC	7416
7417	IC	2	7417	IC	7417
7418	IC	2	7418	IC	7418
7419	IC	2	7419	IC	7419

DATE: 8/22/78
TITLE: 132 BIT STATIC SHIFT REG.
SCALE: 1/8" = 1"

AUG 22 1978

E-REV 3

THIS DOCUMENT IS THE PROPERTY OF WANG LABORATORIES, INC. AND SHALL NOT BE REPRODUCED OR COPIED OR USED AS A BASIS FOR THE MANUFACTURE OR SALE OF ANYTHING OR DEVICE WITHOUT PERMISSION.

HOLE LEGEND			
DRILLED OR	HOLE DIA.	TOL.	
PUNCHED HOLES	.0150 ± .001	± .001	
TOLERANCES	.0150 ± .001	± .001	
	.0150 ± .001	± .001	

LOCATION	W.L. PART NO.	GND	Vcc
L1, 5, 45, 47, 49	376-0005	11	4
L2, 7, 22, 23, 31, 33, 40, 59	376-0002	7	14
L3, 8, 9, 12, 14, 25, 28, 32, 38, 46, 56, 60, 69	376-0010	7	14
L9, 48, 65	376-0028	7	14
L11	376-0154	12	24
L13, 36	376-0003	7	14
L15-18	376-0165	8	16
L19, 24	376-0025	7	14
L20, 21	376-0104	8	16
L26, 61	376-0004	7	14
L29, 70	376-0203	8	16
L30, 91, 54	376-0082	8	16
L50	376-0055	7	14
L34, 58	376-0188	8	16
L37	376-0081	7	14
L39, 52, 53, 55, 64, 68	376-0097	8	16
L40, 67	376-0093	7	14
L42, 43	376-0031	7	14
L44	376-0008	8	16
L51, 57, 62	376-0046	7	14
L63	376-0016	7	14
L6 NOT USED			
L27 NOT USED			
L35	376-0139	7	14

SPARES		
LOCATION	TYPE	QTY
L3	7404	1
L4	7403	3
L8	7404	1
L9	7404	1
L14	7404	1
L19	9935	4
L24	9935	1
L25	7404	2
L32	7404	1
L36	7410	1
L1	7473	1
L46	7404	1
L5	7473	1
L63	7402	1
L13	7410	1

COMPONENT	W.L. PART NO.
R19, 23, 15, 16, 17, 19, 21, 22, 24, 25, 27, 28, 35, 36, 40, 41, 43, 44, 45, 49, 51, 53, 54, 56, 57, 60, 62, 64, 65, 67, 68-75, 76, 78, 80	330-3047
R2-6, 33, 43	330-3010
R18	330-2047
R11, 39, 74, 77	320-2039
R20, 26, 29, 42, 46, 48, 56, 57	330-1110
R23, 39	330-4016
R30, 32	330-4456
R37	330-4433
R36, 50	330-2022
R27	330-4010
R47	330-4012
C7	300-1010
C2, 10	300-1906
C3, 40-46	300-1920
C4, 33	300-1020
C5, 6, 8, 13, 17, 27, 29, 30, 32, 34	300-1390
C9, 10, 11, 18, 22-26, 47, 48	300-1908
C13	300-1913
C14, 16	300-4010
C15	300-4000
C19	300-5001
C24	300-1933
C21, 31	300-5006
C35	300-4021
C36	300-4018
C37, 38, 39, 1	300-4022
REGULATOR	379-0002
JVV1	325-1501
84 PIN SOCKET (L10, 11)	376-9007
D1-12	300-1001
U1	220-3002
J1	376-9001

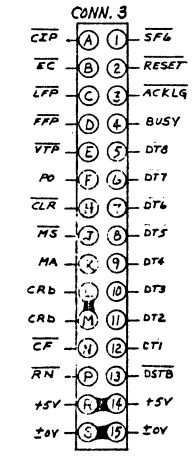
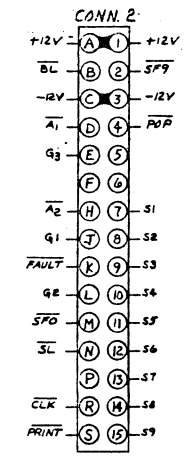
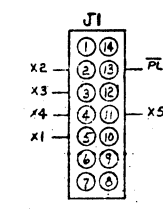
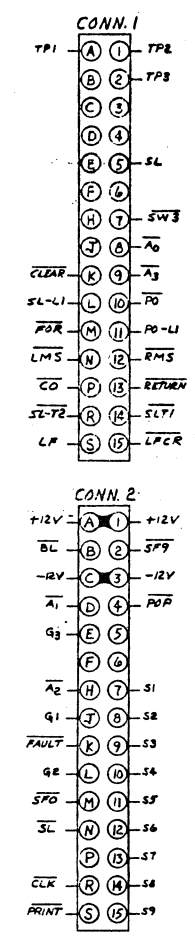
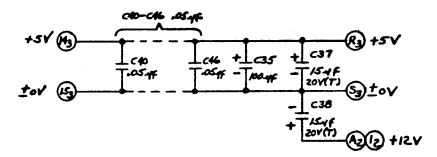
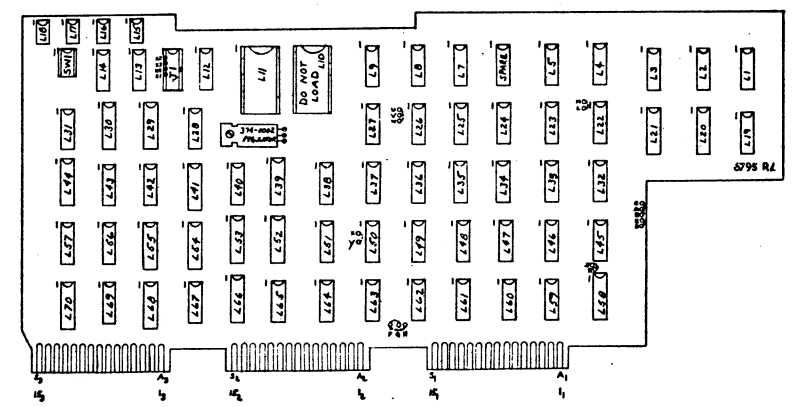

REV 22 1978

WANG PART NO.	ITEM	QTY	NAME	MATERIAL	DESCRIPTION																				
22-31V-3																									
<table border="1"> <tr> <td>WANG LABORATORIES, INC.</td> <td>DATE</td> <td>APPROVED BY</td> <td>DATE</td> </tr> <tr> <td>OWN</td> <td>2/11/78</td> <td>ENGR</td> <td></td> </tr> <tr> <td>CHK</td> <td></td> <td>MG ENGR</td> <td></td> </tr> <tr> <td>E.C. CONTROL</td> <td></td> <td>MG ENGR</td> <td></td> </tr> </table>						WANG LABORATORIES, INC.	DATE	APPROVED BY	DATE	OWN	2/11/78	ENGR		CHK		MG ENGR		E.C. CONTROL		MG ENGR					
WANG LABORATORIES, INC.	DATE	APPROVED BY	DATE																						
OWN	2/11/78	ENGR																							
CHK		MG ENGR																							
E.C. CONTROL		MG ENGR																							
<table border="1"> <tr> <td>MODEL NO.</td> <td>22-31V-3</td> <td>TITLE</td> <td>I/O DATA STORAGE AND FROM CHAR SEM.</td> </tr> <tr> <td>FINISH</td> <td></td> <td>SCALE</td> <td>1/2" = 1"</td> </tr> <tr> <td>SCALE</td> <td>1/2" = 1"</td> <td>WANG PART NUMBER</td> <td>210-6795</td> </tr> <tr> <td>SCALE</td> <td>1/2" = 1"</td> <td>SIZE</td> <td>E 6795</td> </tr> <tr> <td>SCALE</td> <td>1/2" = 1"</td> <td>DRWG NUMBER</td> <td>5</td> </tr> </table>						MODEL NO.	22-31V-3	TITLE	I/O DATA STORAGE AND FROM CHAR SEM.	FINISH		SCALE	1/2" = 1"	SCALE	1/2" = 1"	WANG PART NUMBER	210-6795	SCALE	1/2" = 1"	SIZE	E 6795	SCALE	1/2" = 1"	DRWG NUMBER	5
MODEL NO.	22-31V-3	TITLE	I/O DATA STORAGE AND FROM CHAR SEM.																						
FINISH		SCALE	1/2" = 1"																						
SCALE	1/2" = 1"	WANG PART NUMBER	210-6795																						
SCALE	1/2" = 1"	SIZE	E 6795																						
SCALE	1/2" = 1"	DRWG NUMBER	5																						

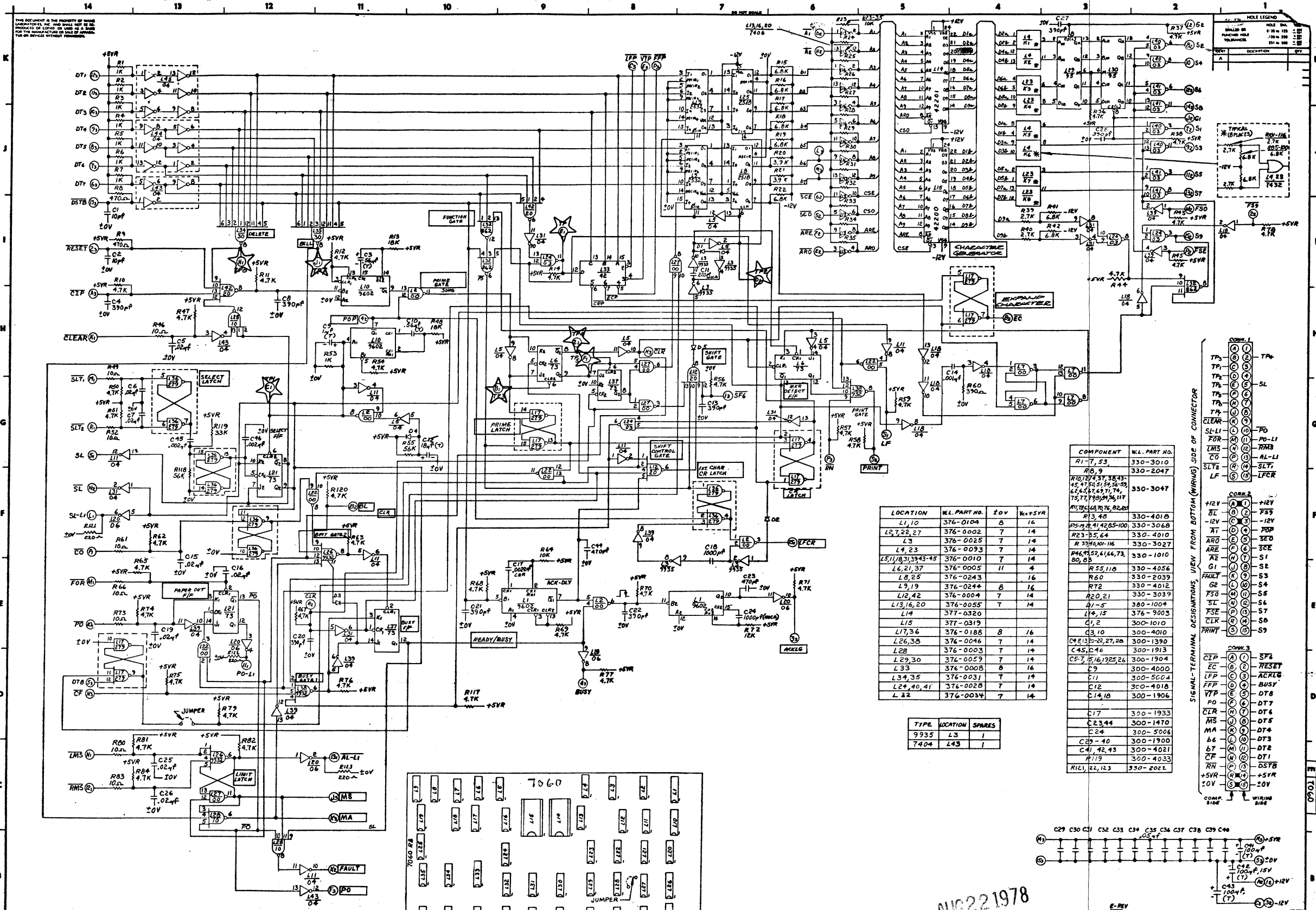

1. ALL CHIPS ARE 7400 SERIES UNLESS OTHERWISE SPECIFIED.

NOTES

REV	DATE	BY	DESCRIPTION
1	11-16-68	WJ	INITIAL DESIGN
2	12-18-68	WJ	REVISED PER APP'D
3	1-15-69	WJ	REVISED PER APP'D
4	2-10-69	WJ	REVISED PER APP'D
5	3-10-69	WJ	REVISED PER APP'D
6	4-10-69	WJ	REVISED PER APP'D
7	5-10-69	WJ	REVISED PER APP'D
8	6-10-69	WJ	REVISED PER APP'D
9	7-10-69	WJ	REVISED PER APP'D
10	8-10-69	WJ	REVISED PER APP'D
11	9-10-69	WJ	REVISED PER APP'D
12	10-10-69	WJ	REVISED PER APP'D
13	11-10-69	WJ	REVISED PER APP'D
14	12-10-69	WJ	REVISED PER APP'D

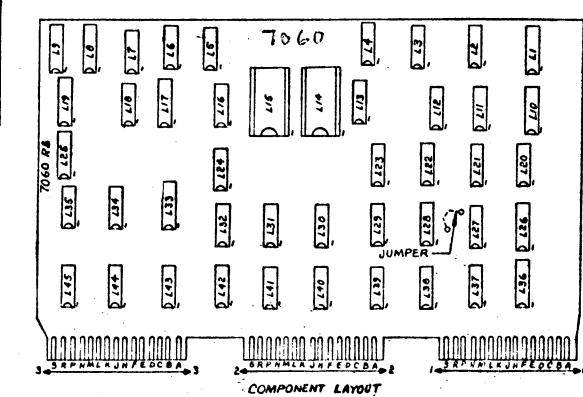

LOCATION	W.L. PART NO.	20V	Wct+SVR
L1,10	376-0104	8	16
L2,22,27	376-0002	7	14
L3	376-0025	7	14
L4,23	376-0093	7	14
L5,11,8,31,39,43,45,47,50,51,59,36,39,62,64,65,67,74,75,77,79,80,81,82,83,84,85,86,87,88,89,90,91,92,93,94,95,96,97,98,99,100	376-0010	7	14
L6,21,37	376-0005	11	4
L8,25	376-0243	8	16
L9,19	376-0244	8	16
L12,42	376-0004	7	14
L13,16,20	376-0055	7	14
L14	377-0320	7	14
L15	377-0319	7	14
L17,36	376-0188	8	16
L26,38	376-0046	7	14
L28	376-0003	7	14
L29,30	376-0059	7	14
L33	376-0008	8	16
L34,35	376-0031	7	14
L24,40,41	376-0028	7	14
L32	376-0034	7	14

TYPE	LOCATION	SPARES
9935	L3	1
7404	L43	1

COMPONENT	W.L. PART NO.
R1-7,53	330-3010
R8,9	330-2047
R10,12,4,37,38,43,45,47,50,51,59,36,39,62,64,65,67,74,75,77,79,80,81,82,83,84,85,86,87,88,89,90,91,92,93,94,95,96,97,98,99,100	330-3047
R1,3,40	330-4010
R5,9,21,41,42,85-100	330-3068
R23-35,64	330-4010
R39,100-106	330-3027
R46,47,53,41,44,73,80,83	330-1010
R55,110	330-4056
R60	330-2039
R72	330-4012
R20,21	330-3039
Q1-5	380-1004
L14,15	376-9003
C1,2	300-1010
C3,10	300-4010
C4,8,13,22,27,28	300-1390
C45,4,6	300-1913
C5-7,5,16,19,25,26	300-1904
C9	300-4000
C11	300-5004
C12	300-4018
C14,18	300-1906
C17	300-1933
C23,44	300-1470
C24	300-5006
C29-40	300-1900
C41,42,43	300-4021
C19	300-4033
R11,12,123	330-2022

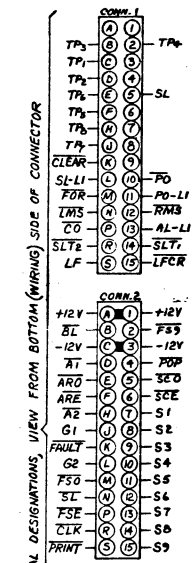

Aug 22 1978

WANG PART NO.	ITEM	QTY	NAME	MATERIAL	DESCRIPTION
210-7060					
WANG			DATE	APPROVED BY	DATE
MODEL NO. 61			E.C. CONTROL MFG ENGR.		
FINISH			TITLE		
			210-7060 E 7060 9		

THIS DOCUMENT IS THE PROPERTY OF WANG LABORATORIES, INC. AND SHALL NOT BE REPRODUCED OR COPIED OR USED AS A BASIS FOR THE MANUFACTURE OR SALE OF APPARATUS OR DEVICES WITHOUT PERMISSION.

HOLE LEGEND		
HOLE DIA	TOR	
0.135 IN	1.25	1.25
0.126 IN	2.50	1.25
0.251 IN	5.00	1.25

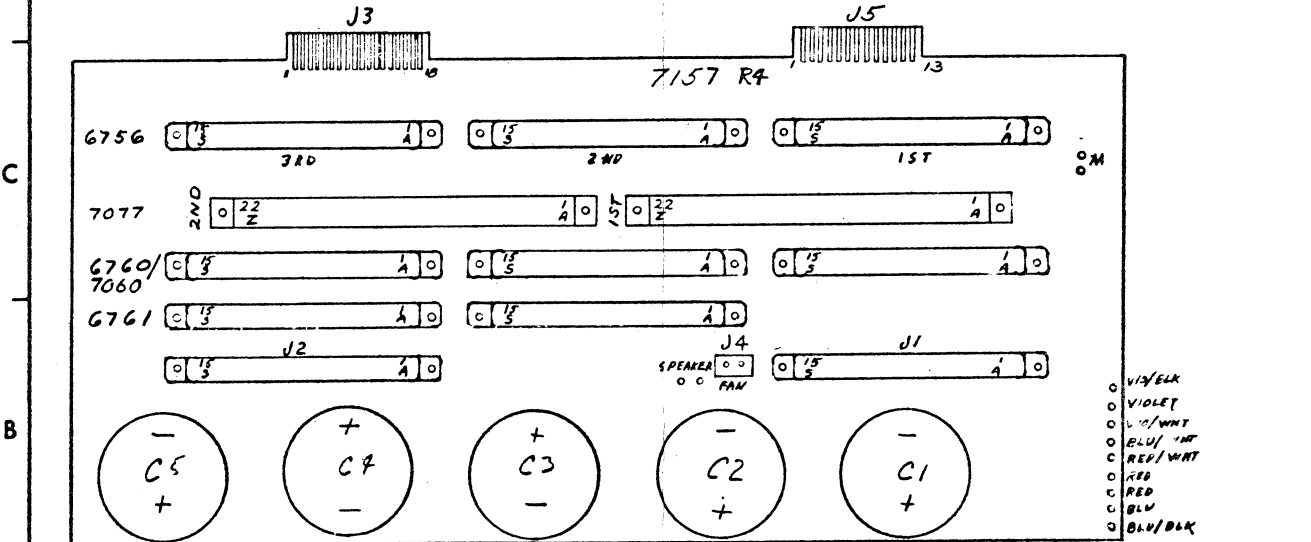
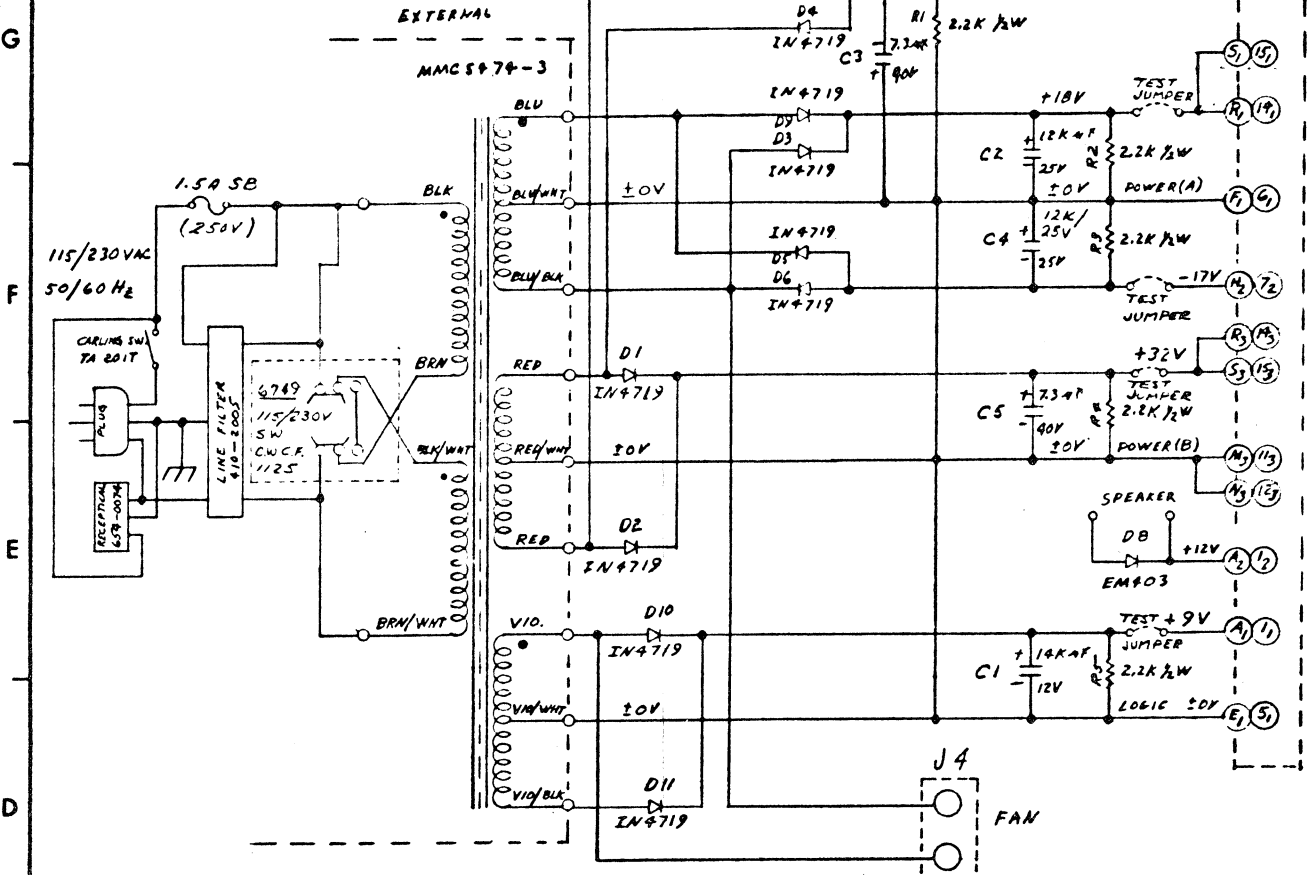

NOTE 1: ALL TEST JUMPERS TO BE #16 GAUGE BUSS WIRE.

REV	DATE	BY	DESCRIPTION
1	9-30-76	W. J. R.	REVISED PER EBA
2	11-11-76	W. J. R.	REVISED PER EBA
3	11-11-76	W. J. R.	REVISED PER EBA
4	11-11-76	W. J. R.	REVISED PER EBA
5	11-11-76	W. J. R.	REVISED PER EBA
6	11-11-76	W. J. R.	REVISED PER EBA
7	11-11-76	W. J. R.	REVISED PER EBA
8	11-11-76	W. J. R.	REVISED PER EBA
9	11-11-76	W. J. R.	REVISED PER EBA

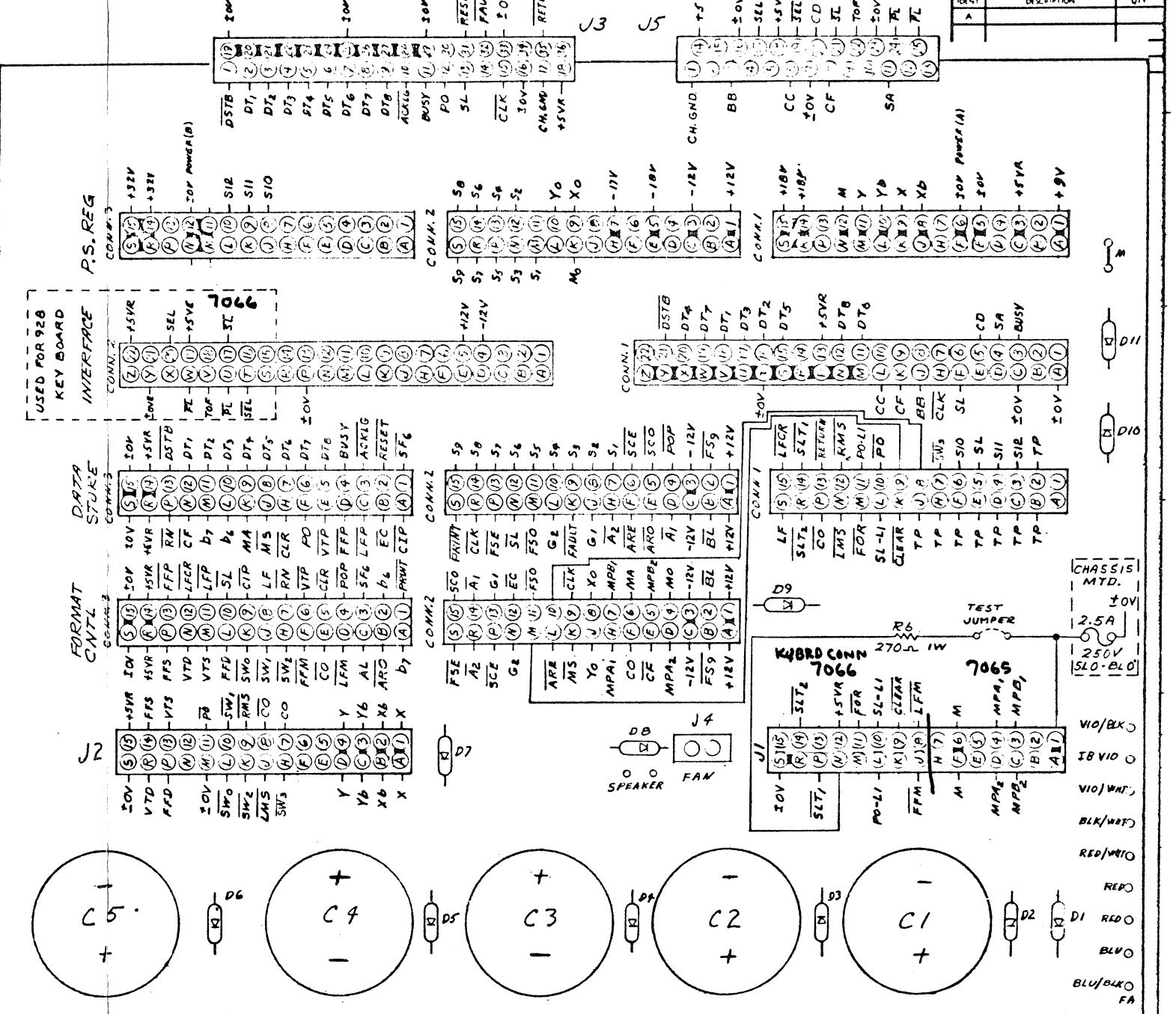

COMPONENT	W.L. PART NO
R1, 2, 3, 4, 5	331-3022
C1	300-3045
C2, 4	300-3076
C3, 5	300-3074
D1-7, 9, 10, 11	380-3002
CONN 30 PIN	350-0011
CONN 36 PIN	300-1044
DB	300-4000
J4 (2 PIN)	654-1198
R6	332-2027

AUG 22 1978

WANG PART NO	ITEM	QTY	NAME	MATERIAL	DESCRIPTION
210-7157	D	1	7157		
7157	7	1			

SECTION 8
MECHANICAL ASSEMBLY DRAWINGS

8.1 INTRODUCTION

Section 8 provides exploded view diagrams of each part of the printer accompanied by each part of the printer accompanied by its Wang part number.

FIGURE	TITLE
8-1	Print Head Assembly
8-2	Paper Guide Cover Assembly
8-3	Lower Paper Guide Assembly
8-4	Cover Assembly
8-5	Right Hand Side Frame Assembly
8-6	Shaft Assemblies
8-7	Left Hand Side Frame Assembly
8-8	Carriage Assembly
8-9	Format Control Assembly
8-10	Chassis Assembly

8.2 PRINT HEAD ASSEMBLY (See Figure 8-1)

(MODEL 61, 10 PITCH: 279-5060-22)

(MODEL 62, 12 PITCH: 279-5060-12)

(MODEL 63, 14.4 PITCH: 279-5060-59)

ITEM NO.	PART NO.	DESCRIPTION	QTY. PER ASSEMBLY
- 1	650-2098	4-40 x 1/4 screw	2
- 2	449-0150	Print head cover	1
- 3	650-4086	8-32 x 15/64 set screw	1
- 4	279-5060-14	Solenoid assy.	9
- 5	650-0064	00-90 x 3/16 screw	2
-6a	465-0245	Print head bearing (10P)	1
-6b	465-0244	Print head bearing (12P)	1
-66	465-0256	Print head bearing (14.4)	1
- 7	449-0131	Ribbon guide	1
- 8	279-5060-13	Head and guide tube assembly 12P	1
- 8	279-5060-23	Head and guide tube assembly 10P	1
- 8	279-5060-83	Head and guide tube assembly 14.4P	1

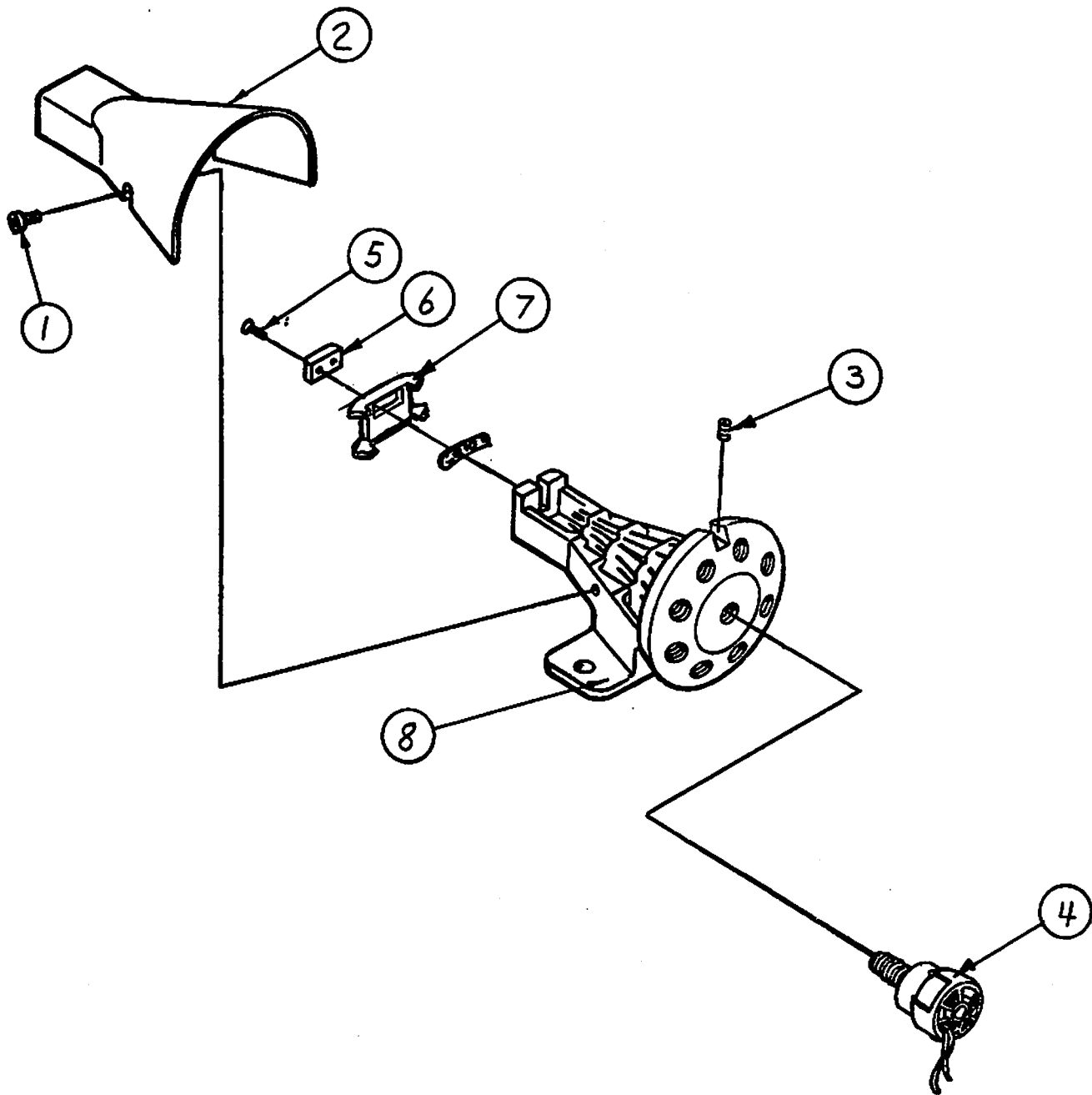

FIGURE 8-1

PAPER GUIDE COVER ASSEMBLY (See Figure 8-2)

Complete Z

(279-5070-38 L.H.)

(279-5070-39 R.H.)

ITEM NO.	PART NO.	DESCRIPTION	QTY. PER ASSEMBLY
- 1	465-1614	Spring	1
- 2	650-3124	6-32 x 3/8 screw	2
- 3	451-2104	Paper guide cover	1
- 4	461-3199	Sprocket cover pivot	2
- 5	650-2098	4-40 x 1/4 screw	2
- 6	458-0305	R.H. paper lift arm	1
	458-0304	L.H. paper lift arm	1
- 7	650-2241	4-40 x 3/4 screw	2
- 8	465-0730	Sprocket bushing	1
- 9	279-5070-41	R.H. paper feed side plate assy.	1
	279-5070-40	L.H. paper feed side plate assy.	1
-10	461-3198	Spring pin	1
-11	655-0167	Paper margin knob	1

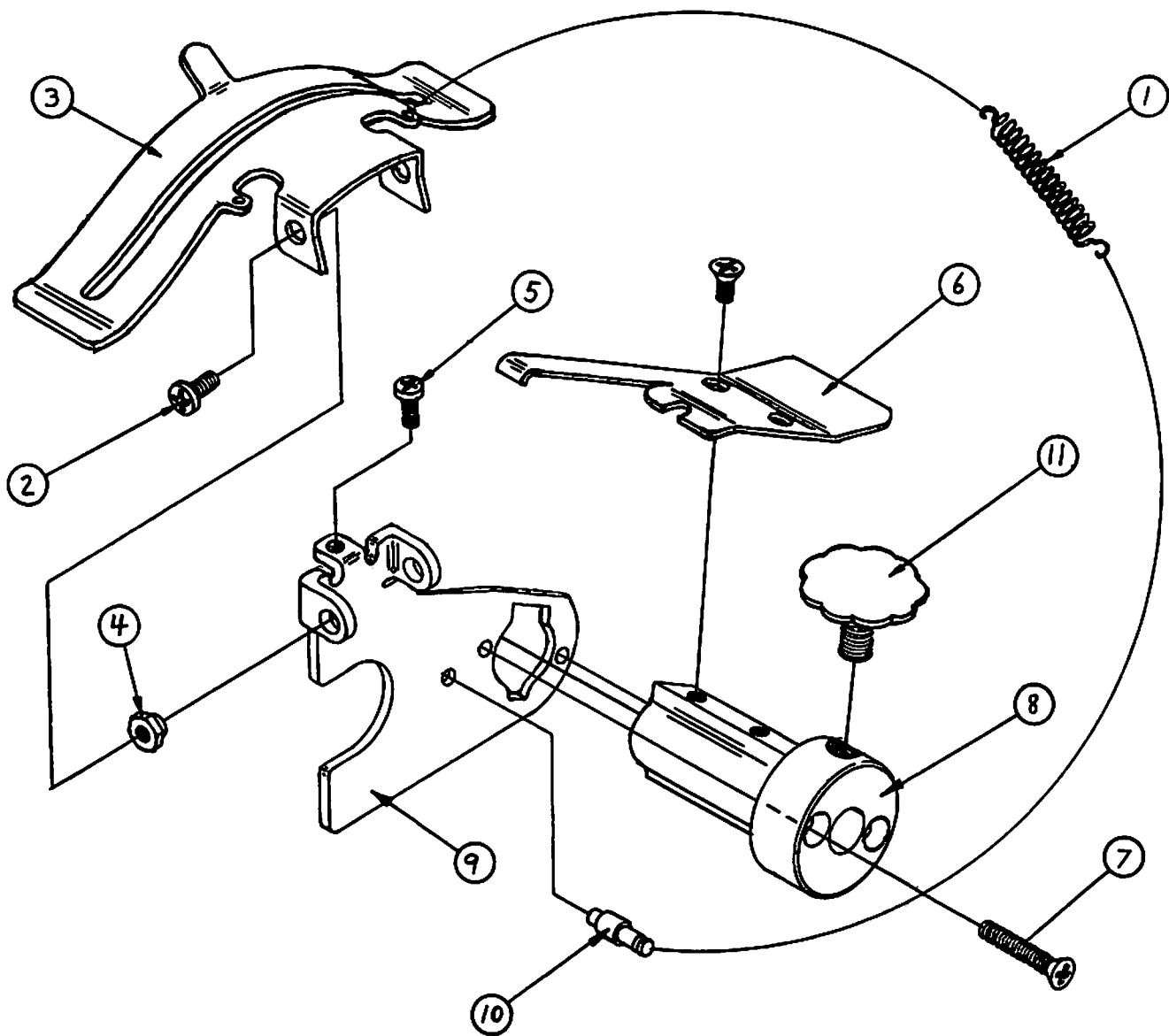

FIGURE 8-2

(NO ASSEMBLY NO.)

ITEM NO.	PART NO.	DESCRIPTION	QTY. PER
- 1	452-0040	Striker plate	1
- 2	650-4200	8-32 x 5/8 screw	4
- 3	653-4000	#8 flat washer	4
- 4	451-4409	R.H. plate mounting bracket	1
	451-4408	L.H. plate mounting bracket	1
- 5	650-4160	8-32 x 1/2 screw	6
- 6	652-4000	8-32 hex nut	2
- 7	653-4003	#8 flat washer	6
- 8	650-4120	8-32 x 3/8 screw	4
- 9	452-4035	Bottom feed paper guide	1
-10	650-4080	8-32 x 1/4 screw	2
-11	653-4002	#8 flat washer	2
-12	461-0103	Nut plate	1
-13	325-2403M1	Paper out switch	1
-14	465-1634	Paper tension spring	1
-15	452-2557	Paper tension clamp	1
-16	652-0025	Pem nut	3
-17	451-4412	Paper tension bracket	1
-18	652-3000	6-32 nut	2
-19	653-3001	#6 lock washer	2
-20	653-3000	#6 flat washer	2
-21	650-2200	4-40 x 5/8 screw	2
-22	653-2004	#4 flat washer	2

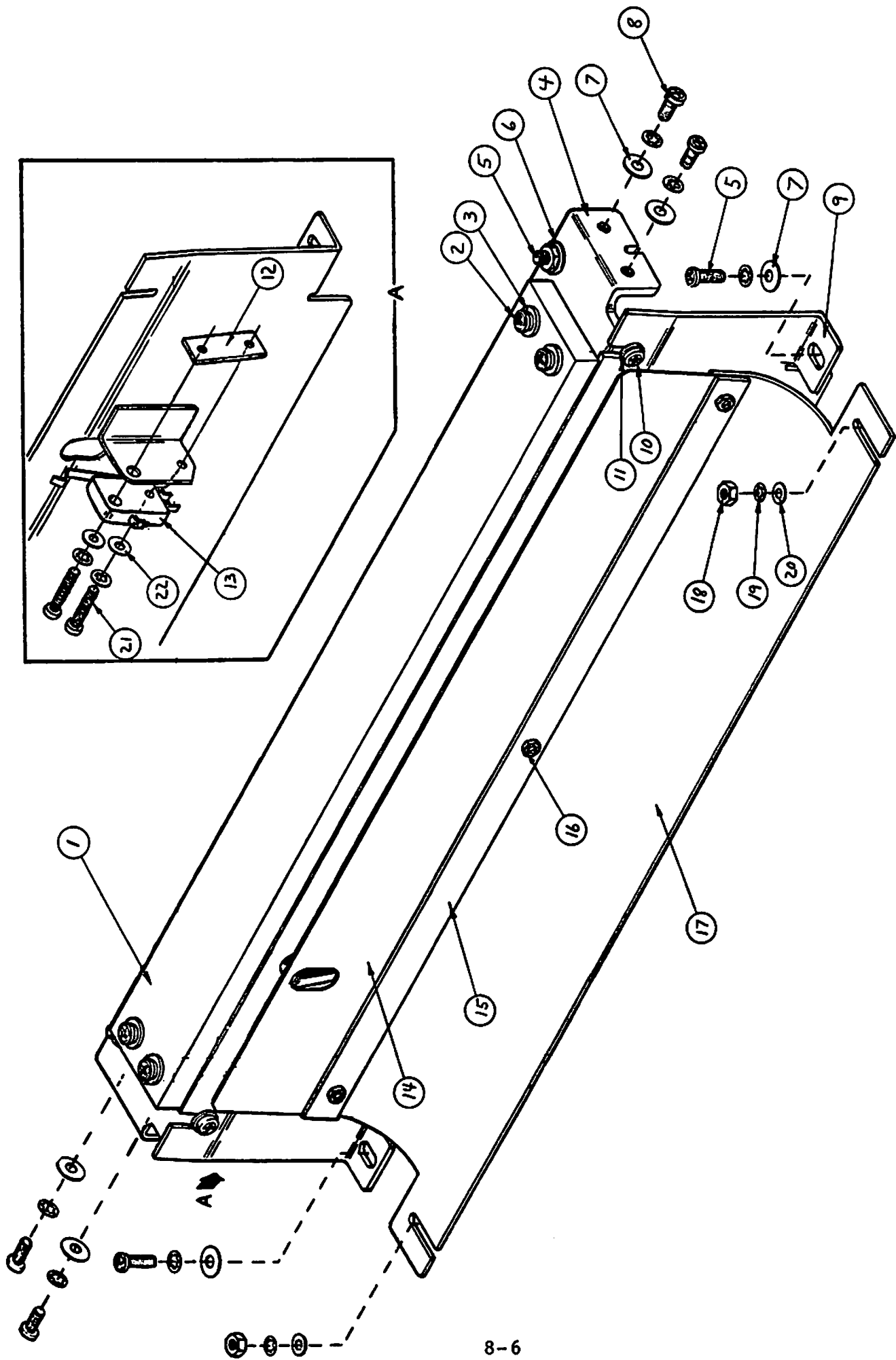

FIGURE 8-3

8.5

COVER ASSEMBLY (See Figure 8-4)

(279-4018)

ITEM NO.	PART NO.	DESCRIPTION	QTY. PER ASSEMBLY
- 1	451-2131	Front cover	1
- 2	449-0128	R.H. side cover	1
- 3	449-0127	L.H. side cover	1
- 4	461-3261	Aligning rod	2
- 5	461-3246	Pivot rod	2
- 6	446-0027	Cover window	1
- 7	452-2556	Window stiffener	1
- 8	650-2121	4-40 x 3/8 screw	2
- 9	450-0061	Wang name tag	1
-10	458-0346	L.H. dress cap	1
	458-0347	R.H. dress cap	1
-11	461-3264	Ball stud	2
-12	660-0554	Side cover screen	2

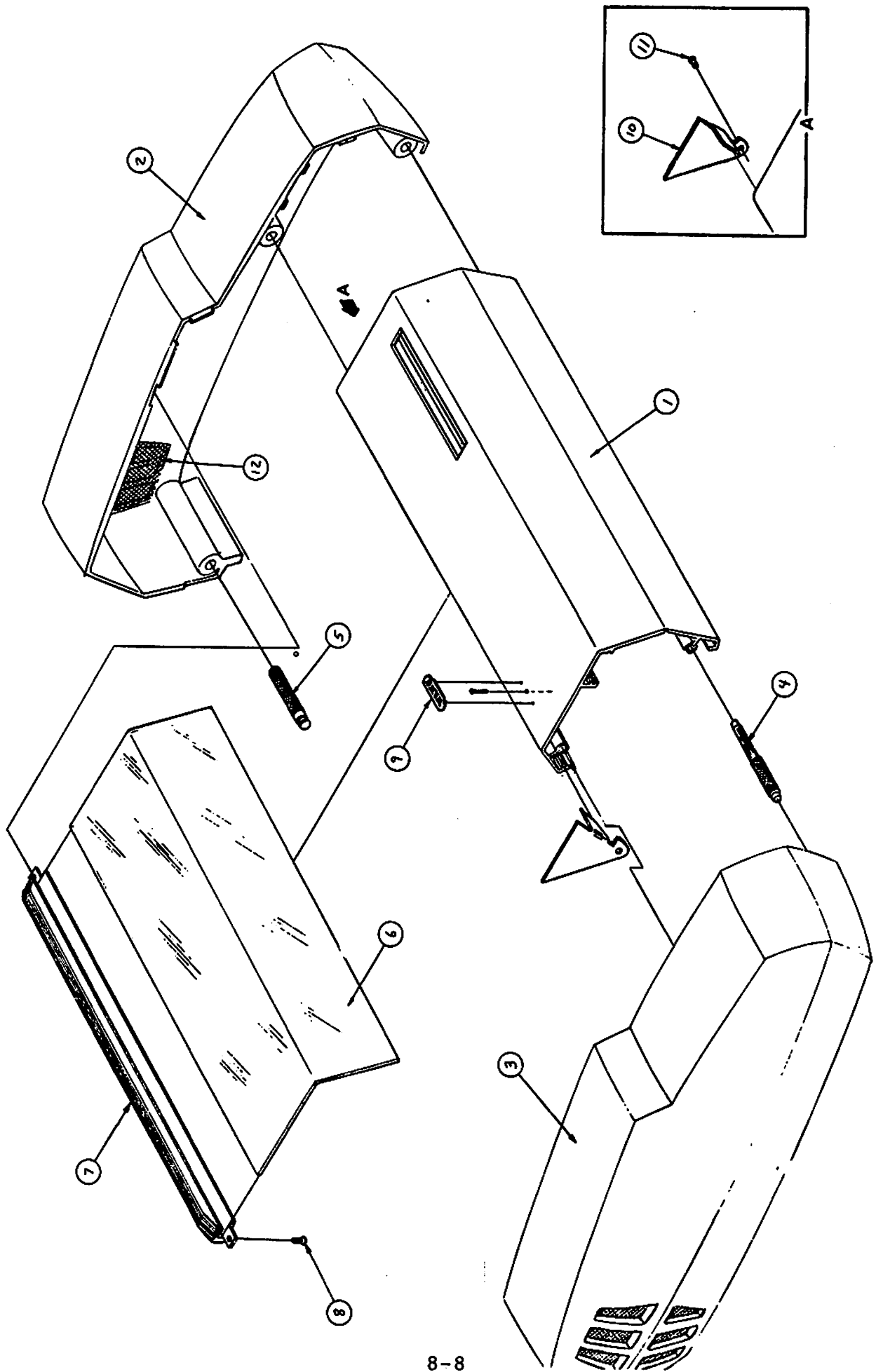

8-8

FIGURE 8-4

(NO ASSEMBLY NO.)

ITEM NO.	PART NO.	DESCRIPTION	QTY. PER ASSEMBLY
- 1	650-4133	8-32 x 3/8 screw	3
- 2	452-0043	Side frame	1
3-11	279-0226	Fan assembly	1
- 3	400-9004	Fan blade	1
- 4	650-3322	6-32 x 1 1/2 screw	2
- 5	653-3000	#6 flat washer	10
- 6	452-3535	Fan shield	1
- 7	400-9005	Wire fan guard	1
- 8	653-3001	#6 lock washer	2
- 9	652-3000	6-32 hex nut	2
-10	462-0264	Spacer	2
-11	400-0020	Fan motor	1
-12	650-9013	1/4-20 x 1/2 screw	4
-13	654-1286	Cable clamp	2
14-25	279-5060-15	Carriage Motor/Encoder Assy-2231W-1	1
14-25	279-5060-16	Carriage Motor/Encoder Assy-2231W-2	1
14-25	279-5060-17	Carriage Motor/Encoder Assy-2231W-3	1
14-19	279-5060-26	Encoder bracket assembly	1
-14	653-4000	#8 flat washer	2
-15	653-4001	#8 lock washer	12
-16	650-4080	8-32 x 1/4 screw	10
-17	651-1516	Roll pin	1
-18	452-0042	Adjusting plate	1
-19	451-4405	Encoder bracket	1

-20	325-2417	Magnetic pickup	2
-21a	461-2021	Encoder pickup gear (10P)	1
-21b	461-2020	Encoder pickup gear (12P)	1
-21c	461-2027	Encoder pickup gear (14.4P)	1
-22	465-0417	Cable collar	2
-23	650-4120	8-32 x 3/8 screw	2
26-28	279-5060-17	Vernier pivot arm assy.	1
-26	651-1521	Roll pin	1
-27	451-4401	Actuator pivot bracket	1
-28	458-0333	Vernier actuating arm	1
-29	465-0721	Bushing	1
-30	465-0728	Cable bushing	2
-31	650-4240	8-32 x 3/4 socket head screw	1
-32	465-1631	Cable tension spring	2
-33	449-0137	Vernier knob	1
-34	462-0258	Shaft spacer	1
-35	650-4320	8-32 x 1 screw	1
-36	451-4407	Hold down bracket	4
-37	650-3120	6-32 x 3/8 screw	8

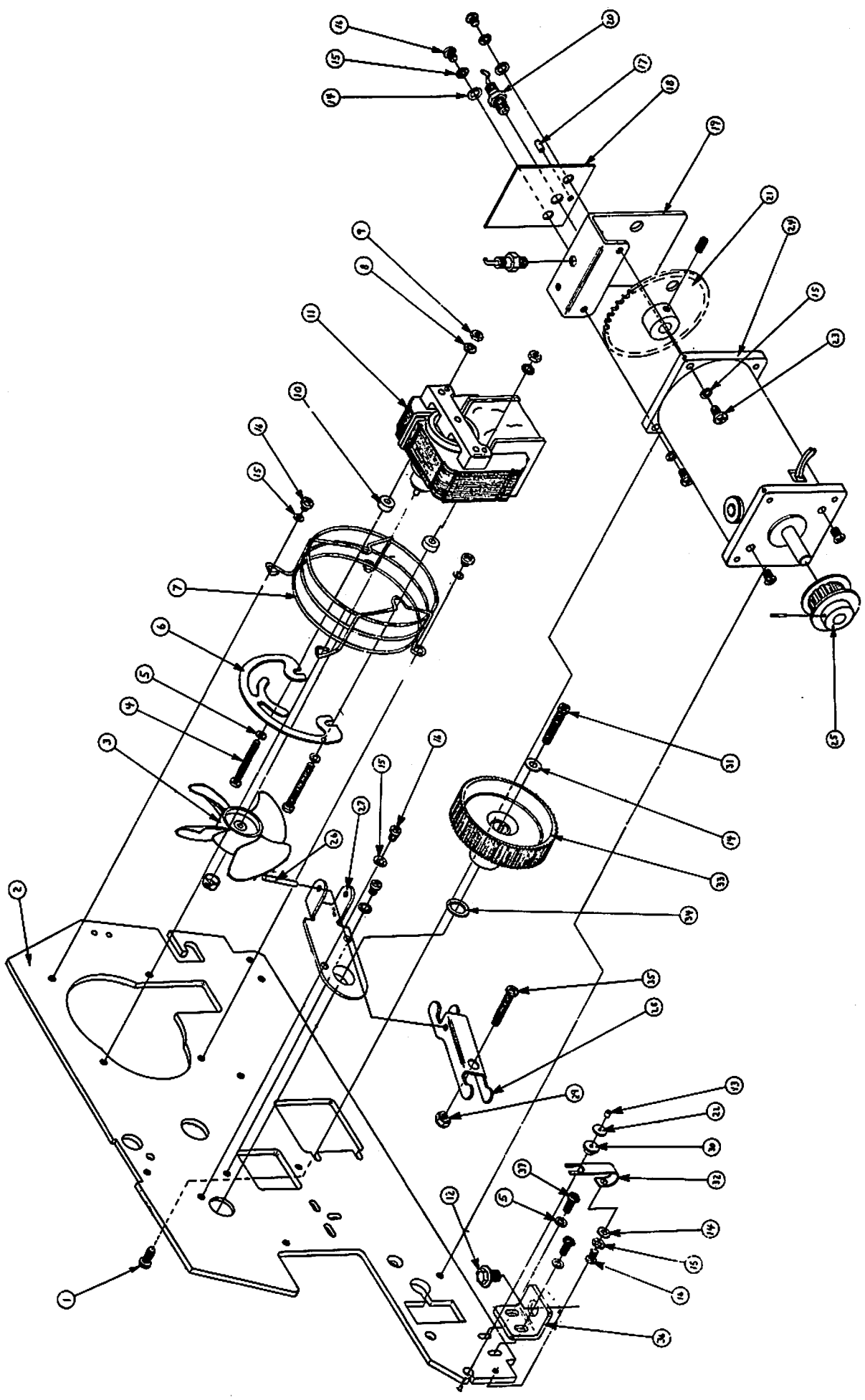

FIGURE 8-5

(NO ASSEMBLY NO.)

ITEM NO.	PART NO.	DESCRIPTION	QTY. PER ASSEMBLY
- 1	449-0133	Vernier pulley	1
- 2	449-0126	Paper drive spur gear	1
- 3	449-0132	Vernier cone	1
- 4	465-1632	Vernier dutch spring	1
- 5	462-0258	Shaft spacer	4
- 6	651-1747	Snap ring	2
- 7	465-1626	Cartridge Spring	1
- 8	465-0721	Bushing	3
- 9	452-0043	R.H. side frame	1
-10	279-5060-27	Wire rope assembly	1
-11	461-1029	Paper support disc	2
-12	461-3239	Carriage shaft	1
-13	461-3240	Spline shaft	1
-14	465-1628	Disc separator spring	3
15-24	279-5070-39	R.H. paper guide assy.	1
-15	451-2104	Paper guide cover	1
-16	650-3124	6-32 x 3/8 screw	2
-17	461-3199	Sprocket cover pivot	2
-18	452-0046	R.H. paper feed side plate	1
-19	465-1614	Spring	1
-20	650-2062	4-40 x 3/16 screw	2
-21	461-3198	Spring pin	1
-22	458-0305	R.H. paper lift arm	1
-23	465-0730	Sprocket bushing	1
-24	650-2241	4-40 x 3/4 screw	2
	279-5070-38	L.H. paper guide assy.	1

-25	655-0167	Paper margin knob	2
-26	653-3000	#6 flat washer	2
-27	461-3234	Guide rod	1
-28	651-1719	Snap ring	2
-29	462-0259	Shaft spacer	3
-30	465-1630	Spring	1
-31	451-4408	L.H. plate mounting bracket	1
-32	449-0139	Nylon bushing	1
-33	653-6000	#10 flat washer	1
-34	650-6120	10-32 x 3/8 screw	1
-35	651-1748	Push-on retainer	1
-36	478-0258	Sprocket pulley	2
-37	461-3235	Vernier actuating rod	1
-38	650-6127	10-32 x 3/8 screw	2
-39	461-3248	R.H. pivot pin	1
	461-3247	L.H. pivot pin	1
-40	656-0225	Timing belt	1
-41	461-3233	Roller shaft	1
-42	451-4409	R.H. plate mounting bracket	1
-43	655-0236	Carriage bumper	2
-44	650-4200	8-32 x 5/8 screw	4
-45	653-4001	#8 lock washer	4
-46	653-4000	#8 flat washer	4
-47	452-0040	Striker plate	1
-48	279-5060-19	Carriage plate assembly	1
-49	451-4403	Reed switch bracket	1
-50	650-3134	6-32 x 3/8 screw	2
-51	279-5060-32	Vernier shaft assembly	1
-52	279-5060-35	L.H. side frame assy.	1
NOT SHOWN	279-5060-80	2231W-3 Cluster Pulley Assy	1

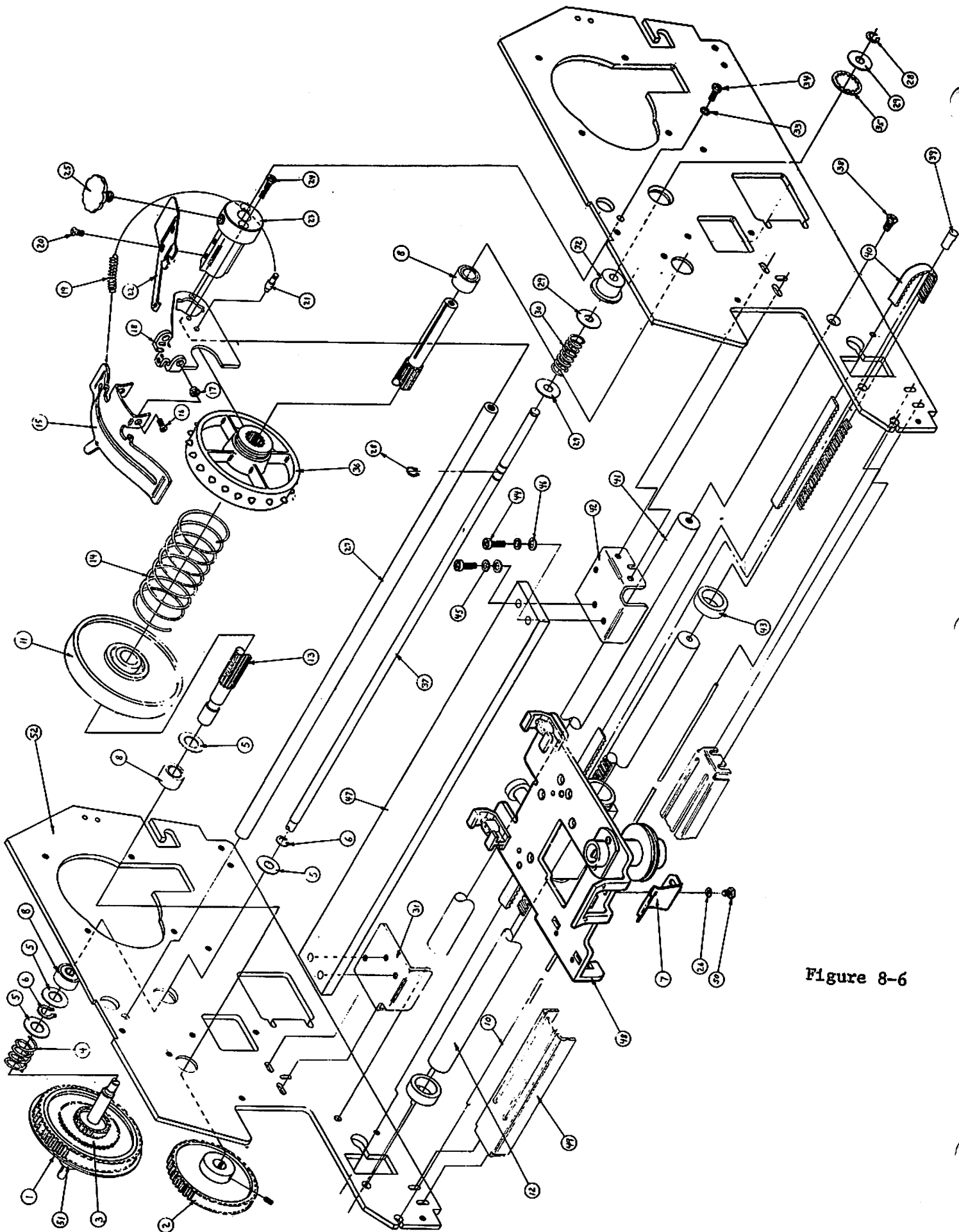

Figure 8-6

(NO ASSEMBLY NO.)

ITEM NO.	PART NO.	DESCRIPTION	QTY. PER ASSEMBLY
- 1	279-5060-35	Side frame assy.	1
- 2	452-0044	Format control plate	1
- 3	652-4000	8-32 hex nut	3
- 4	449-0135	Tape sprocket	1
- 5	279-5060-32	Vernier shaft assembly	1
- 6	449-0125	Idler spur gear	1
- 7	651-1719	Snap ring	1
- 8	461-3242	Idler gear pivot	1
- 9	279-5060-28	Idler gear bracket assy.	1
-10	650-4120	8-32 x 3/8 screw	8
-11	653-4000	#8 flat washer	13
-12	279-5060-45	Motor bracket assy.	1
-13	650-4205	8-32 x 5/8 socket head screw	1
-14	279-5060-37	Paper feed motor assy.	1
-15A	449-0124	Paper drive pulley 31W-1/2	1
-15B	478-0377	Paper drive Pully 31W-3	1
-16	650-4160	8-32 x 1/2 screw	4
-17	652-4000	8-32 hex nut	1
-18	279-5060-45	Paper feed bushing	1
-19	462-0258	Shaft spacer	1
-20	651-1747	Snap ring	1
-21	449-0126	Paper drive spur gear	1
-22	279-5060-35	Bushing assembly	1
-23	461-3240	Spline shaft	1
-24	461-3234	Guide rod	1
-25	650-6120	10-32 x 3/8 screw	1
-26	650-4200	8-32 x 5/8 screw	2
-27	600-9102	Steel cable	1
-28	452-0040	Striker plate	1
-29	451-4408	Platen mounting bracket	1
-30	465-0728	Clutch cable bushing	1

-31	465-0417	Clutch cable collar	1
-32	452-4035	Bottom feed paper guide	1
-33	325-2403M1	Paper out switch	1
-34	461-0103	Nut plate	1
-35	650-2200	4-40 x 5/8 screw	2
-36	653-2000	#4 flat washer	2
-37	451-4412	Paper tension bracket	1
-38	465-1634	Paper tension spring	1
-39	452-2557	Paper tension clamp	1
-40	652-0063	4-40 stop nut	1
-41	451-4403	Reed switch bracket	1
-42	461-0102	Nut plate	1
-43	451-4407	Hold down bracket	1
-44	650-4133	8-32 x 3/8 screw	2
-45	458-0275	Carrier cable end fitting	1
-46	651-1732	Snap ring	1
47-55	279-5060-33	Idler pulley assy.	1
-47	653-0040	#4 flat washer	2
-48	449-0123	Carriage drive idler pulley	1
-49	465-0248	Needle bearing	1
-50	461-3238	Idler pulley stud	1
-51	451-4402	Idler pulley bracket	1
-52	653-6006	1/4 flat washer	1
-53	652-0064	1/4-28 nut	1
-54	465-1627	Head adjusting detent spring	1
-55	650-4080	8-32 x 1/4 screw	2
-56	653-4001	#8 lock washer	1
-57	650-6160	10-32 x 1/2 screw	1
-58	461-3233	Roller shaft	1
-59	461-3239	Carriage shaft	1
-60	653-0016	Nylon washer	1
-61	461-3247	L.H. pivot pin	1
-62	651-1749	Snap ring	1
-63	458-0334	Head adjustment arm	1
-64	550-0067	Adjustment arm cap	1
NOT SHOWN	656-0234	Form Feed Belt 31W-3	1

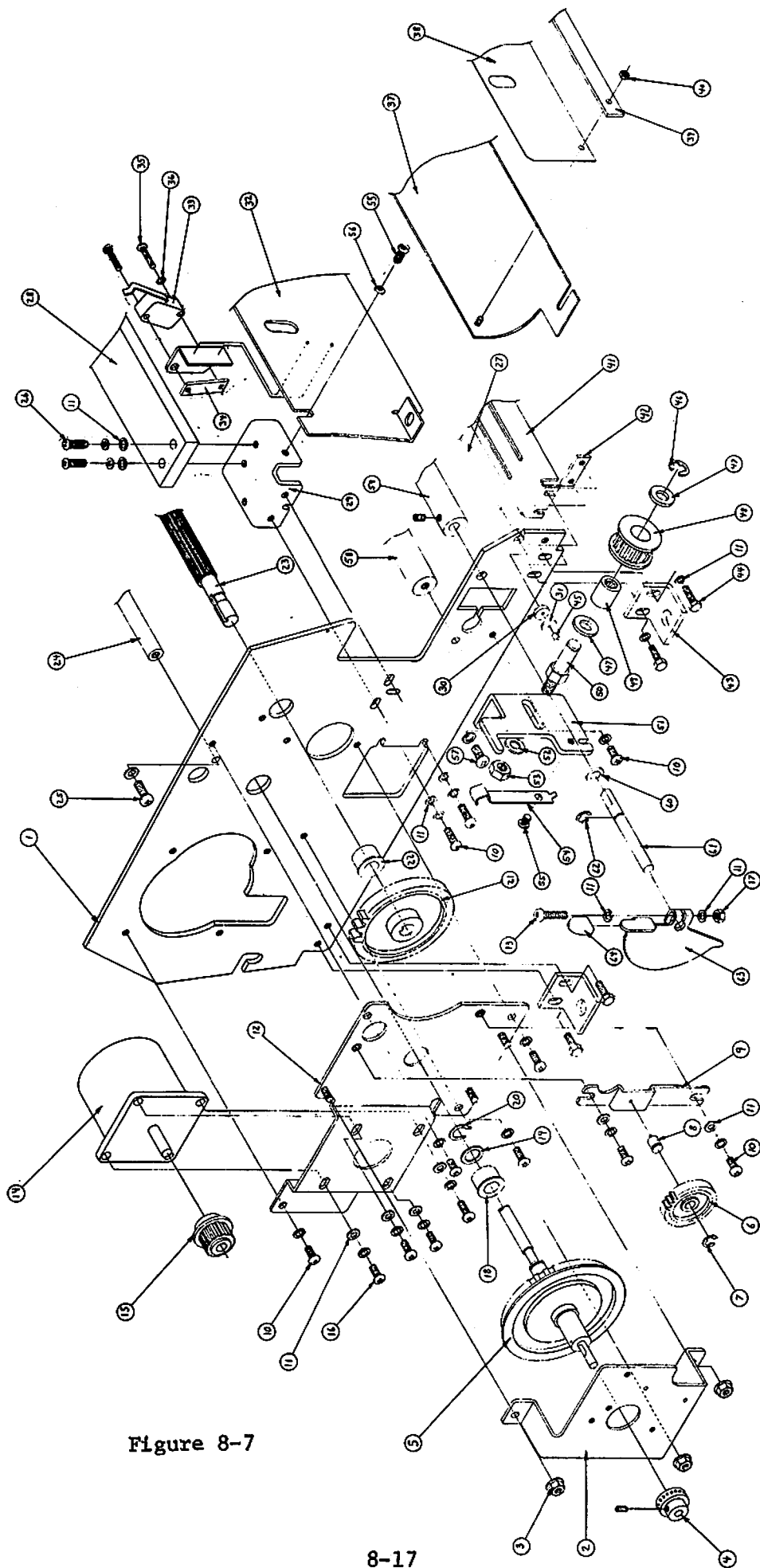

Figure 8-7

(279-5060-19)

ITEM NO.	PART NO.	DESCRIPTION	QTY. PER ASSEMBLY
	279-5060-27	WIRE ROPE ASS'Y	
- 1	279-5060-21	Carriage plate assembly	1
- 2	451-4400	Flex cable bracket	1
- 3	650-3080	6-32 x 1/4 screw	4
- 4	650-3100	6-32 x 5/16 screw	3
- 5	653-3000	#6 flat washer	3
- 6	458-0352	Head PC board retainer	1
- 7	465-1626	Cartridge spring	1
- 8	650-3134	6-32 x 3/8 socket head screw	4
- 9	449-0136	Carriage roller	2
-10	462-0257	Spring spacer	1
-11	279-5060-24	Ribbon drive housing assy.	1
-12	650-3081	6-32 x 1/4 screw	2
-13	279-5060-25	Wire pulley assy.	1
-14	651-1719	Snap ring	1
-15	449-0134	Cartridge guide	2
-16	461-3270	Carriage bearing housing (alum.)	1
	461-3273 3270	Carriage bearing housing (molded)	1
-17	656-0225	Timing belt	1
-18	452-2554	Belt top clamp	1
-19	452-2555	Belt bottom clamp	1
-20	465-0243	Sleeve bearing	2
-20A	449-0138	BLACK RETAINER	
-21	650-0120	2-56 x 3/8 socket head screw	1
-22	651-1712	Snap ring	3
-23	461-3236	Eccentric pin	1
-24	651-1724	Retaining ring	2
-25	465-1629	Spring	1
-26	465-0729	Eccentric pin bushing	1
-27	656-1006	Magnet	1
-28	461-3237	Roller pin	1
-29	279-5060-53 279-5060-50?	CARRIAGE BEARING HOUSING ASS'Y (INCLUDES 16, 20, + 20A)	

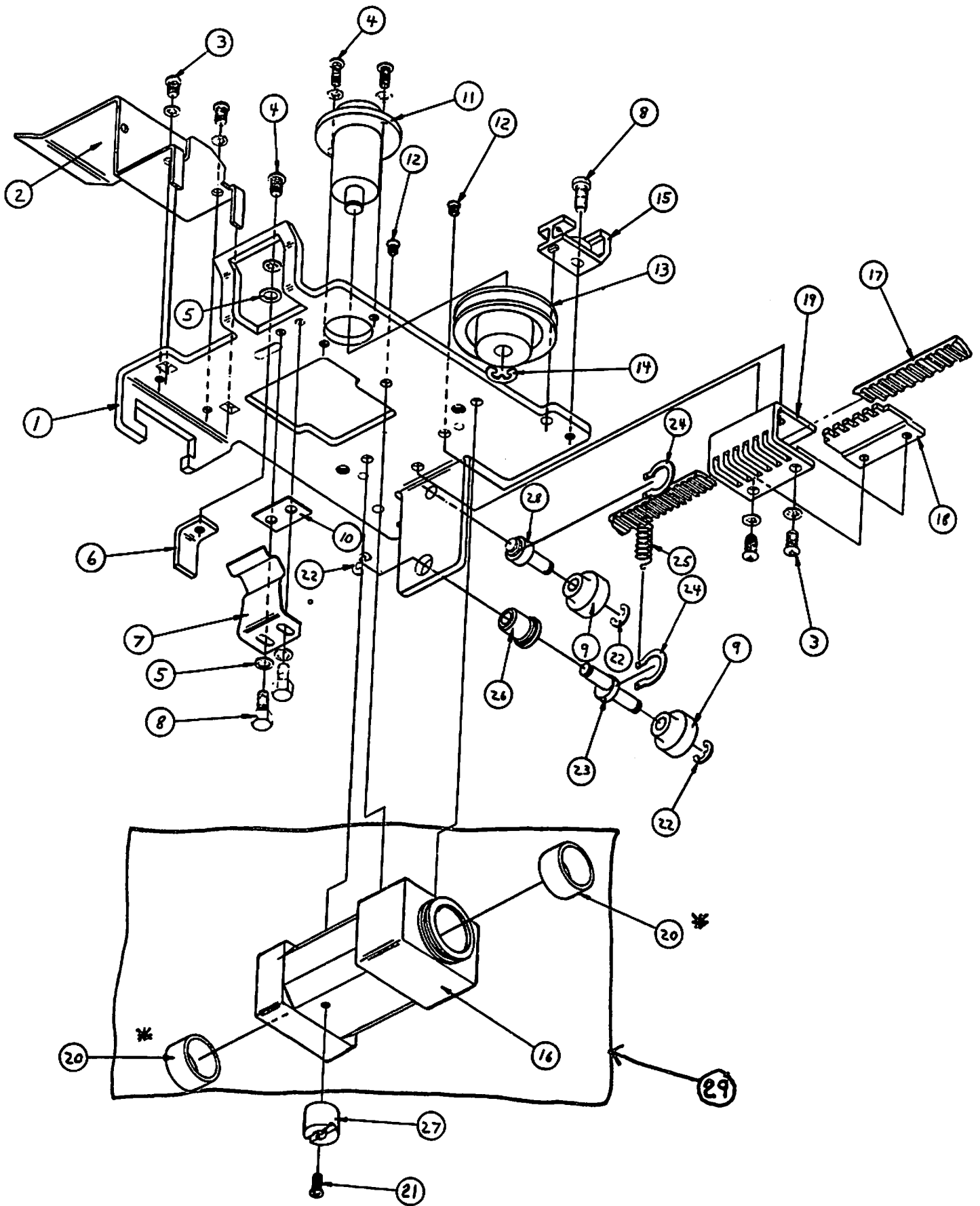

FIGURE 8-8

(279-5060-29)

ITEM NO.	PART NO.	DESCRIPTION	QTY. PER ASSEMBLY
- 1	279-5060-30	Format control plate assy.	1
- 2	458-0295	Format control stop	2
- 3	650-3134	6-32 x 3/8 socket head screw	2
- 4	210-6575	Module	2
- 5	651-0014	#2 x 1/4 screw	2
- 6	279-5060-36	Phototransistor housing assy.	1
- 7	465-0252	Bearing	1
- 8	461-3191	L.E.D. Housing	1
- 9	653-2000	#4 flat washer	3
-10	651-0015	#4 x 1/4 screw	2
-11	462-0229	L.E.D. cover spacer	1
-12	279-5070-31	L.E.D. housing cover assy.	1
-13	465-0409	Set screw collar	1
-14	461-3182	L.E.D. pivot pin	1
-15	461-3181	Spring pin	2
-16	465-0938	Torsion spring	1
-17	650-2043	Set screw	1
-18	651-0016	#4 x 1/2 screw	1
-19	650-3100	6-32 x 5/16 screw	1
-20	653-3000	#6 flat washer	1

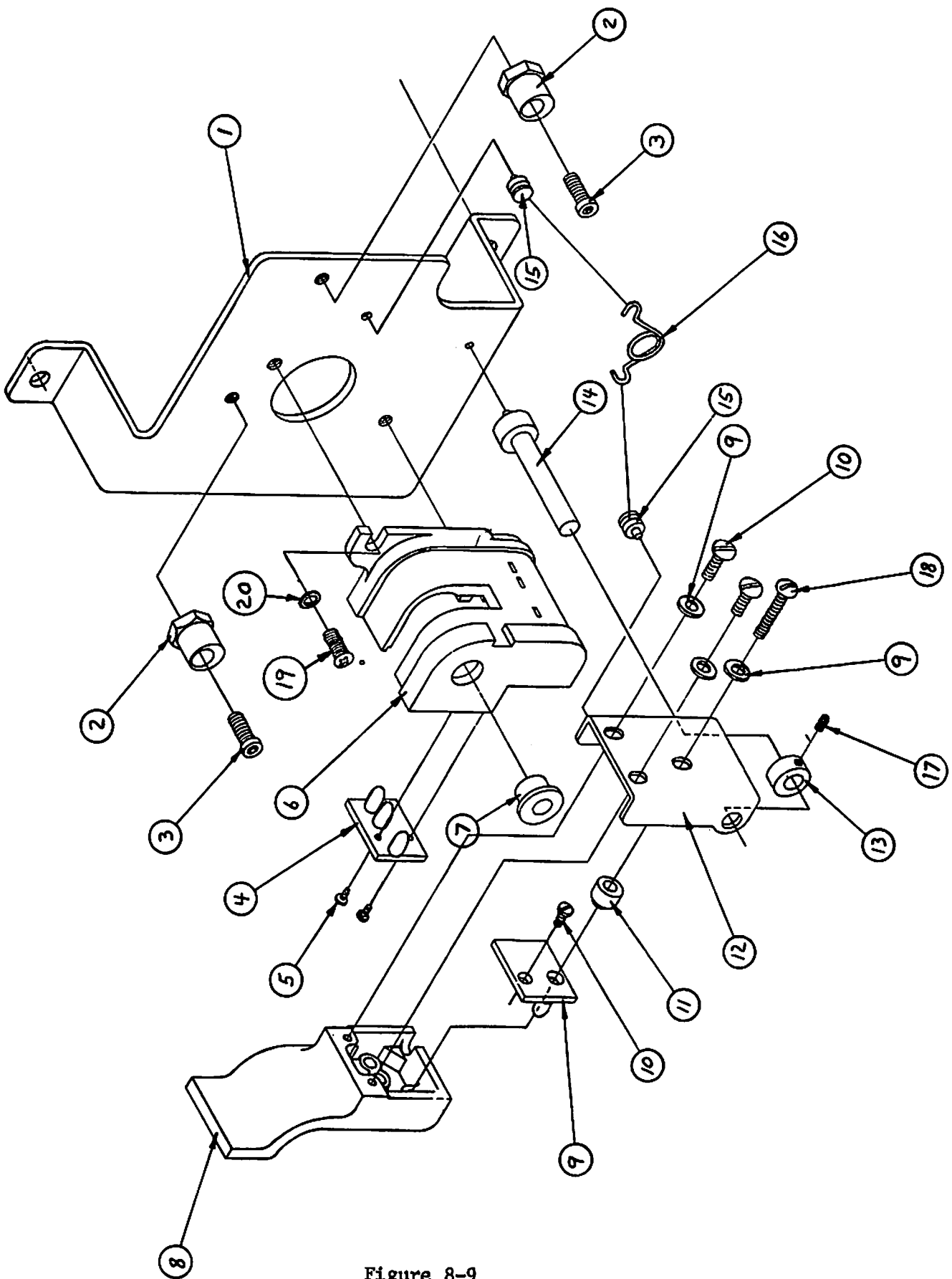

Figure 8-9

(270-0300)

ITEM NO.	PART NO.	DESCRIPTION	QTY. PER ASSEMBLY
- 1	210-7157	7157 Module	1
- 2	410-0102	Transformer	1
- 3	451-1096	Chassis, silk screened	1
- 4	410-2006	Line Filter 3S1 3 amp	1
- 5	452-3536	Shield, AC	1
- 6	510-6749	6749 P/C board	1
- 7			
- 8	451-4476	Brkt., fuse mtg.	1
- 9	360-1008SB	8/10 Amp SLO BLO fuse 250V	1
-10	360-1016SB	1 1/2 Amp fuse SLO BLO 250V	1
-11	462-0060	Plate cover (RS232)	1
-12	605-1004	PAN-TY	12
-13	605-0010	#8 Clear tubing	.25
-14	300-9009	Clamp, 1 1/4" dia 2 lub cap (CMC-22)	5
-15	320-0300	Speaker, 3" rect. (FILMOR TS-27)	1
-16	325-0021	ON-OFF rocker switch (SPDT)	1
-17	325-2112	Switch, 115/230 VAC slide	1
-18	360-0001	Holder, straight contact fuse	2
-19	360-9000	Washer, rubber fuse	2
-20	360-9002	Nut, hex fuse	2
-21	360-9003	Washer, lock fuse	2
-22	380-5001	250V Varistor V250 LA 20	1
-23	420-1000	Cord, 3 cond. power	1
-24	462-0141	Spacer, phenolic current 4-250	3
-25	650-1123	SEMS, 3-48 x 3/8 PAN HD PHL	2
-26	650-2240	SEMS, 4-40 x 3/4 PAN HD PHL	10
-27	650-3080	SEMS, 6-32 x 1/4 PAN HD PHL	10
-28	650-3092	Screw, 6-32 x 1/4 FLAT HD PHL	2
		100 degrees C'SK	

-29	650-3120	SEMS, 6-32 x 3/8 PAN HD PHL	7
-30	650-3200	Screw, 6-32 x 5/8 PAN HD PHL	5
-31	651-1027	PEM STUD FHS 440-12	3
-32	651-0404	Rivet, (Avex 1604-0412) POP	2
-33	652-0032	Nut, 6-32 KEPS	5
-34	652-2005	4-40 KEPS nut	13
-35	653-3000	Nut, 6-32 HEX	1
-36	653-0003	Washer, #4 nylon	13
-37	653-2000	Washer, #4 flat	13
-38	653-2002	Washer, #4 INT T Lock	2
-39	653-3003	Washer, #6 split lock	2
-40	653-6000	Washer, #10 flat	4
-41	654-1006	Lug, #6 ground	1
-42	654-1290	Snap bushing SB-1.00-12	2
-43	654-1238	Grommet, (HEYCO SP-4)	1
-44	654-0074	AC receptacle	1
-45	600-2004	24 GA yellow wire	1.25
-46	650-6120	Screw, #10-32 x 3/8 PAN HD PHL	4
-47	653-6001	Washer, #10 INT. T. lock	4
-48	651-1005	PEM nut FHS 4-40-6	4
-49	650-2087	4-40 x 1/4 Pan HD PHL SEMS	2
-50	605-0127	#16 Teflon Tubing	.25
-51	652-0008	PEM nut CL632-2	20
-52	652-0060	PEM nut CLL032-1	4
-53	651-1016	PEM stud FHS632-10	1
-54	600-0000	18 GA black wire	1
-55	600-0009	18 GA white wire	1
-56	600-0054	18 GA grn/yel wire	1
-57	605-0014	#5 Clear tubing	.50

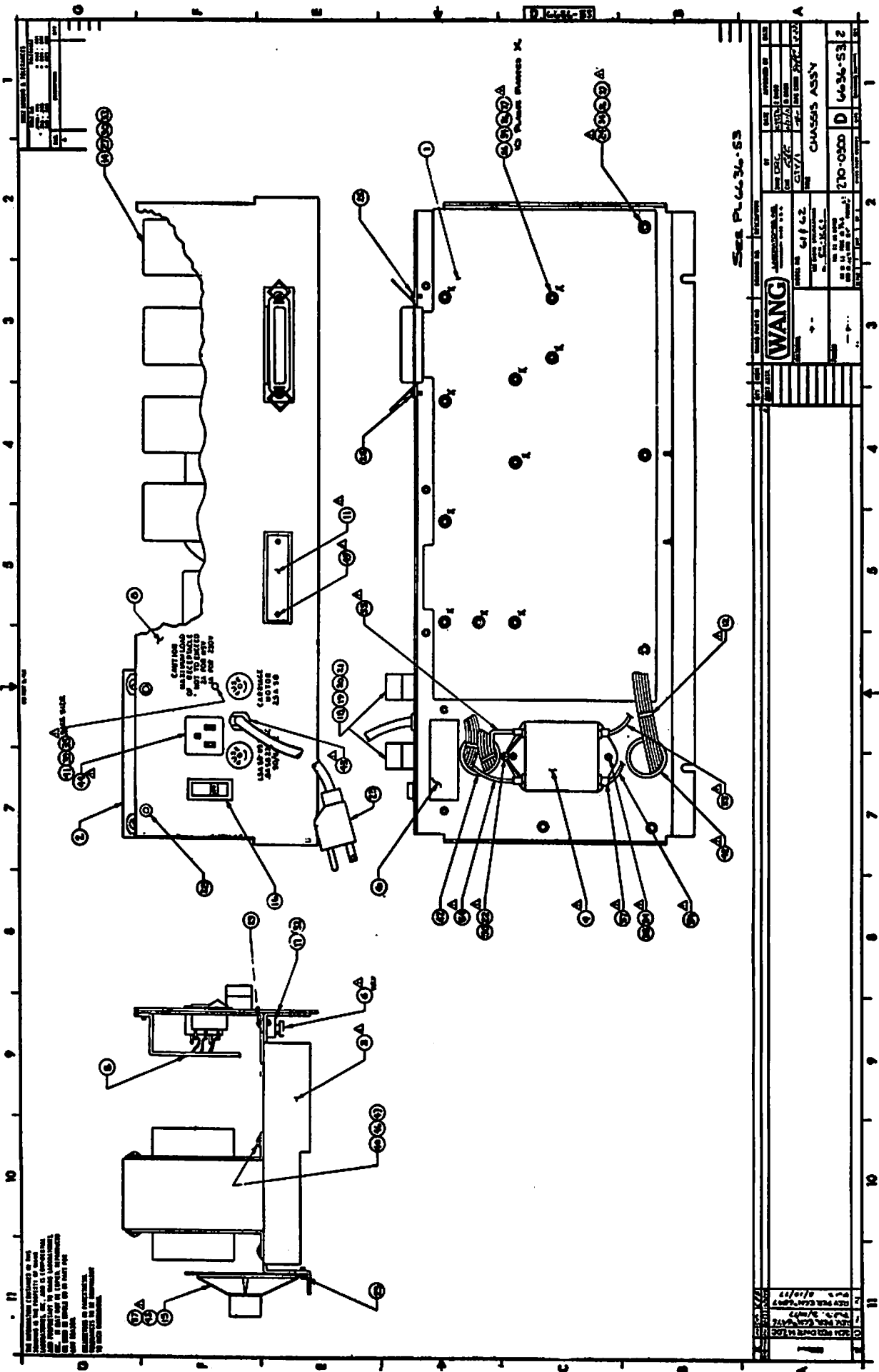

FIGURE 8-10

SECTION 9
APPENDICES

APPENDIX A
HEXADECIMAL CODES

HEX CODE	PRINTER CHARACTER	HEX CODE	PRINTER CHARACTER	HEX CODE	PRINTER CHARACTER
HEX(07)	Alarm	HEX(3D)	=	HEX(60)	a
HEX(0A)	Line Feed	HEX(3E)	>	HEX(61)	b
HEX(0B)	Vertical Tab	HEX(3F)	?	HEX(62)	c
HEX(0C)	Form Feed	HEX(40)	@	HEX(63)	d
HEX(0D)	Carriage Return	HEX(41)	A	HEX(64)	e
HEX(0E)	Elongated Character	HEX(42)	B	HEX(65)	f
HEX(20)	Space	HEX(43)	C	HEX(66)	g
HEX(21)	!	HEX(44)	D	HEX(67)	h
HEX(22)	"	HEX(45)	E	HEX(68)	i
HEX(23)	#	HEX(46)	F	HEX(69)	j
HEX(24)	\$	HEX(47)	G	HEX(6A)	k
HEX(25)	%	HEX(48)	H	HEX(6B)	l
HEX(26)	&	HEX(49)	I	HEX(6C)	m
HEX(27)	'	HEX(4A)	J	HEX(6D)	n
HEX(28)	(HEX(4B)	K	HEX(6E)	o
HEX(29))	HEX(4C)	L	HEX(6F)	p
HEX(2A)	*	HEX(4D)	M	HEX(70)	q
HEX(2B)	+	HEX(4E)	N	HEX(71)	r
HEX(2C)	,	HEX(4F)	O	HEX(72)	s
HEX(2D)	-	HEX(50)	P	HEX(73)	t
HEX(2E)	.	HEX(51)	Q	HEX(74)	u
HEX(2F)	/	HEX(52)	R	HEX(75)	v
HEX(30)	0	HEX(53)	S	HEX(76)	w
HEX(31)	1	HEX(54)	T	HEX(77)	x
HEX(32)	2	HEX(55)	U	HEX(78)	y
HEX(33)	3	HEX(56)	V	HEX(79)	z
HEX(34)	4	HEX(57)	W	HEX(7A)	{
HEX(35)	5	HEX(58)	X	HEX(7B)	}
HEX(36)	6	HEX(59)	Y	HEX(7C)	~
HEX(37)	7	HEX(5A)	Z	HEX(7D)	
HEX(38)	8	HEX(5B)	[HEX(7E)	
HEX(39)	9	HEX(5C)]	*HEX(7F)	
HEX(3A)	:	HEX(5D)	↑		
HEX(3B)	;	HEX(5E)	↓		
HEX(3C)	<	HEX(5F)	←		

*ASCII DEL, a non-printable control character

APPENDIX B
SIGNAL MNEMONICS

<u>SIGNAL</u>	<u>DEFINITION</u>
A1 - A9	Address bits of ROMS
<u>ACK DELAY</u>	Acknowledge delay
<u>ACKLG</u>	Acknowledge at I/O interface
<u>AL</u>	Alarm (output to speaker)
<u>ALL1</u>	Fault indicator
<u>ARE</u>	Read strobe for ROM (even)
<u>ARO</u>	Read strobe for ROM (odd)
b1 - b7	Output of shift registers
<u>BELL</u>	Audio function pulse
<u>BL</u>	Bell
<u>BUSY</u>	Device busy status for I/O
<u>CF</u>	Carriage forward
<u>CIP</u>	Control input prime
<u>CLEAR</u>	Manual clear switch
<u>CLK</u>	System clock
<u>CLR</u>	System clear
<u>CO</u>	Cover open switch
<u>CRb</u>	Carriage Return by Reed Switch
<u>CRP</u>	Carriage return decoded
D1a - D9a	9Bit output of character generator ROMS (odd)
D1b - D9b	9Bit output of character generator ROMS (even)
<u>DELETE</u>	Delete function pulse
<u>DT1 - DT8</u>	Data input at I/O interface
<u>DSTB</u>	Data strobe at I/O interface
<u>DX</u>	Dot or not Dot
<u>EC</u>	Expanded character
<u>FAULT</u>	Fault status at I/O interface
<u>FFD</u>	Form feed LED anode
<u>FFM</u>	Form feed manual switch
<u>FFP</u>	Form feed pulse
<u>FFS</u>	Form feed phototransistor emitter
<u>FOR</u>	Form override switch
<u>FS9</u>	Enable Solenoid Nine
<u>FSE</u>	Fire solenoid (even)
<u>FSO</u>	Fire solenoid (odd)
G1	Pulse 1 of print timing
G2	Pulse 2 of print timing
K1	Pulse 4 of print timing
K2	Pulse 5 of print timing
<u>LD</u>	Line Feed Drive
<u>LF</u>	Line feed
<u>LFCR</u>	Line feed developed from first character carriage return
<u>LFD</u>	Line Feed Delay
<u>LFM</u>	Line feed manual switch
<u>LFP</u>	Line feed pulse
<u>LMS</u>	Left margin switch
<u>M</u>	Output of servo motor driver
<u>MA</u>	Master alarm
<u>M0</u>	Output of servo motor amplifier
<u>MKE</u>	Marker Bit

<u>MPA₁</u>	Magnetic pickup (tooth)
<u>MPA₂</u>	Magnetic pickup common (tooth)
<u>MPB₁</u>	Magnetic pickup (hole)
<u>MPB₂</u>	Magnetic pickup common (hole)
<u>MS</u>	Margin stop
<u>PL</u>	Plot Mode
<u>PO</u>	Paperout status at I/O interface
<u>POL1</u>	Paperout lamp (form override)
<u>POP</u>	Power-On-Prime
<u>PRINT</u>	Initiates print cycle
<u>PS</u>	Prime
<u>RDY/BUSY</u>	READY/BUSY (Low for Busy)
<u>RESET</u>	Input prime at I/O interface
<u>RMS</u>	Right margin switch
<u>RN</u>	Run F/F output (carriage in motion)
<u>S1-S9</u>	Print Solenoids
<u>SFM</u>	Start Forward Motion
<u>S01 - S09</u>	Collector of solenoid drivers
<u>S9</u>	Base of solenoid drivers
<u>SCE</u>	Select chip (even)
<u>SCO</u>	Select chip (odd)
<u>SFO</u>	Set Firing
<u>SF6</u>	Used to shift out next character from buffer
<u>SL</u>	Select status
<u>SLL1</u>	Select indicator
<u>SLT1</u>	Select switch (NO)
<u>SLT₂</u>	Select switch (NC)
<u>SW0</u>	Home position switch
<u>SW1</u>	Deceleration switch
<u>SW2</u>	Return switch
<u>VTD</u>	Vertical tab LED anode
<u>VTP</u>	Vertical tab pulse
<u>VTS</u>	Vertical tab phototransistor emitter
<u>WS</u>	Window Strobe
<u>X</u>	Output to motor winding (X)
<u>X_o</u>	Output to stepping motor amplifier (X)
<u>X_b</u>	Common for motor winding (X)
<u>Y</u>	Output to motor winding (Y)
<u>Y_o</u>	Output to stepping motor amplifier (Y)
<u>Y_b</u>	Common for motor winding (Y)

North America:

Alabama

Birmingham
Mobile

Alaska

Anchorage

Arizona

Phoenix
Tucson

California

Fresno
Inglewood
Los Angeles
Sacramento
San Diego
San Francisco
San Mateo
Sunnyvale
Tustin
Ventura

Colorado

Denver

Connecticut

New Haven
Stamford
Wethersfield

District of Columbia

Washington

Florida

Jacksonville
Miami
Orlando
Tampa

Georgia

Atlanta

Hawaii

Honolulu

Illinois

Chicago
Morton
Park Ridge
Rock Island

Indiana

Indianapolis
South Bend

Kansas

Overland Park
Wichita

Kentucky

Louisville

Louisiana

Baton Rouge
Metairie

Maryland

Rockville
Towson

Massachusetts

Boston
Burlington
Littleton
Lowell
Tewksbury
Worcester

Michigan

Grand Rapids
Okemos
Southfield

Minnesota

Eden Prairie

Missouri

Creve Coeur

Nebraska

Omaha

Nevada

Reno

New Hampshire

East Derry
Manchester

New Jersey

Howell
Mountainside

New Mexico

Albuquerque

New York

Albany
Buffalo
Lake Success
New York City
Rochester
Syracuse

North Carolina

Charlotte
Greensboro
Raleigh

Ohio

Cincinnati
Columbus
Middleburg Heights
Toledo

Oklahoma

Oklahoma City
Tulsa

Oregon

Beaverton
Eugene

Pennsylvania

Allentown
Camp Hill
Erie
Philadelphia
Pittsburgh
Wayne

Rhode Island

Cranston

South Carolina

Charleston
Columbia

Tennessee

Chattanooga
Knoxville
Memphis
Nashville

Texas

Austin
Dallas
Houston
San Antonio

Utah

Salt Lake City

Virginia

Newport News
Richmond

Washington

Seattle
Spokane

Wisconsin

Brookfield
Madison
Milwaukee

Canada

Wang Laboratories
(Canada) Ltd.
Don Mills, Ontario
Calgary, Alberta
Edmonton, Alberta
Winnipeg, Manitoba
Ottawa, Ontario
Montreal, Quebec
Burnaby, B.C.

International Subsidiaries:

Australia

Wang Computer Pty. Ltd.
Sydney, NSW
Melbourne, Vic.
Canberra, A.C.T.
Brisbane, Qld.
Adelaide, S.A.
Perth, W.A.
Darwin, N.T.

Austria

Wang Gesellschaft M.B.H.
Vienna

Belgium

Wang Europe, S.A.
Brussels
Erpe-Mere

Brazil

Wang do Brasil
Computadores Ltda.
Rio de Janeiro
Sao Paulo

China

Wang Industrial Co., Ltd.
Taipei, Taiwan

France

Wang France S.A.R.L.
Bagnolet
Ecully
Nantes
Toulouse

Great Britain

Wang Electronics Ltd.
Northwood Hills, Middlesex
Northwood, Middlesex
Harrogate, Yorkshire
Glasgow, Scotland
Uxbridge, Middlesex

Hong Kong

Wang Pacific Ltd.
Hong Kong

Japan

Wang Computer Ltd.
Tokyo

Netherlands

Wang Nederland B.V.
Ijsselstein

New Zealand

Wang Computer Ltd.
Grey Lynn, Auckland

Panama

Wang de Panama
(CPEC) S.A.
Panama

Republic of Singapore

Wang Computer Pte., Ltd.
Singapore

Republic of South Africa

Wang Computers
(South Africa) (Pty.) Ltd.
Bordeaux, Transvaal
Durban
Capetown

Sweden

Wang Skandinaviska AB
Solna
Gothenburg
Arloev
Vasteras

Switzerland

Wang S.A./A.G.
Zurich
Bern
Pully

West Germany

Wang Laboratories GmbH
Berlin
Cologne
Duesseldorf
Fellbach
Frankfurt/M.
Freiburg/Brsg.
Hamburg
Hannover
Kassel
Munich
Nuernberg
Stuttgart

International Representatives:

Argentina
Bolivia
Canary Islands
Chile

Colombia
Costa Rica
Cyprus
Denmark
Dominican Republic
Ecuador

Finland
Ghana
Greece
Guatemala
Iceland

India
Indonesia
Iran
Ireland

Israel
Italy
Jamaica
Japan
Jordan

Kenya
Korea
Lebanon
Liberia
Malaysia
Mexico
Morocco
Nicaragua
Nigeria
Norway
Pakistan
Peru
Philippines
Portugal
Saudi Arabia
Spain
Sri Lanka
Syria
Thailand
Tunisia
Turkey
United Arab Emirates
Venezuela
Yugoslavia

WANG

LABORATORIES, INC.

ONE INDUSTRIAL AVENUE, LOWELL, MASSACHUSETTS 01851, TEL. (617) 851-4111, TWX 710 343-6769, TELEX 94-7421

Printed in U.S.A.
13-2393
10-78-2.8M