

WANG

2232B
DIGITAL FLATBED
PLOTTER
USER MANUAL

SYSTEM 2200

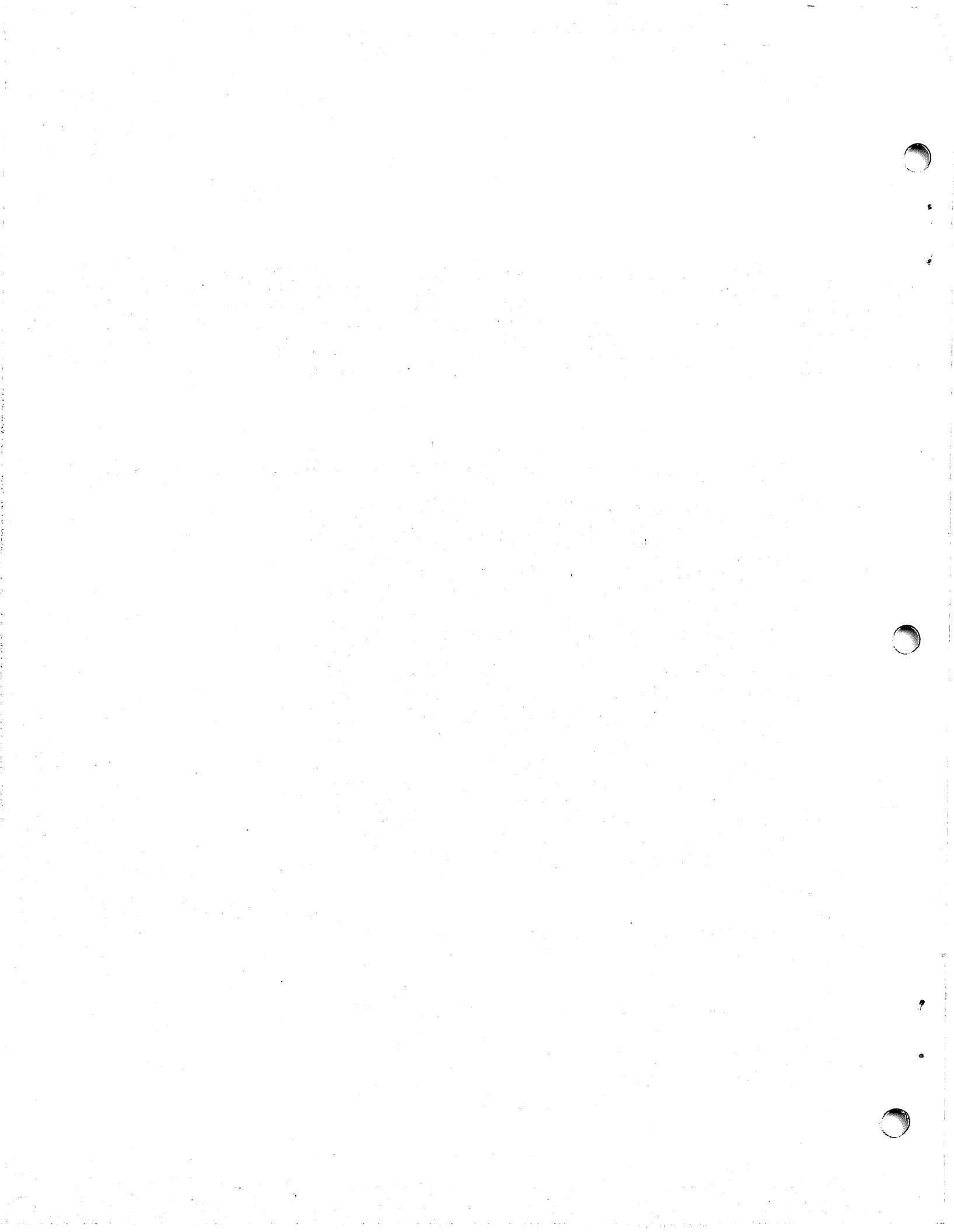



2232B

DIGITAL FLATBED

PLOTTER

USER MANUAL

© 1974, 1976, 1977 Wang Laboratories, Inc.



LABORATORIES, INC.

ONE INDUSTRIAL AVENUE, LOWELL, MASSACHUSETTS 01851, TEL. (617) 851-4111, TWX 710 343-6769, TELEX 94-7421

HOW TO USE THIS MANUAL

This manual provides the user with a concise reference to the operational features of the Model 2232B Digital Flatbed Plotter. It is assumed that the user of the Model 2232B is familiar with the BASIC language of the System 2200. A discussion of System 2200 BASIC commands and statements can be found in the Wang BASIC Language Reference Manual. Specifications are provided in Appendix B; cleaning and maintenance procedures are found in Appendix A.

TABLE OF CONTENTS

CHAPTER 1 INTRODUCTION	1
Unpacking and Packing Instructions	2
Installation Procedure	2
Power-On Procedure	3
Preventive Maintenance Procedures	3
Lubrication	3
Cleaning	3
Squaring X Shaft	4
Making Y Arm Perpendicular to the X Shaft	4
CHAPTER 2 THE PLOT STATEMENT	5
Selecting the Model 2232B	5
Round-Off Error	5
PLOT	6
APPENDIX A MODEL 2232B ACCESSORIES	7
Standard Equipment Enclosed With Each Model 2232B	7
Optional Package of Accessory Equipment for the Model 2232B	8
Paper Recommendations	8
Ink Recommendations	9
Plotter Points	9
Care and Cleaning	9
Pen Pressure Adjustment	9
Pen Height Adjustment	10
Loading Procedure for Ball Pen	10
Loading Procedure for Ink Pen	10
Loading Procedure for Fiber Pen	11
APPENDIX B MODEL 2232B SPECIFICATIONS	13
APPENDIX C EQUIPMENT GUARANTEE AND MAINTENANCE AGREEMENT	15
INDEX	17
CUSTOMER COMMENT FORM	last page

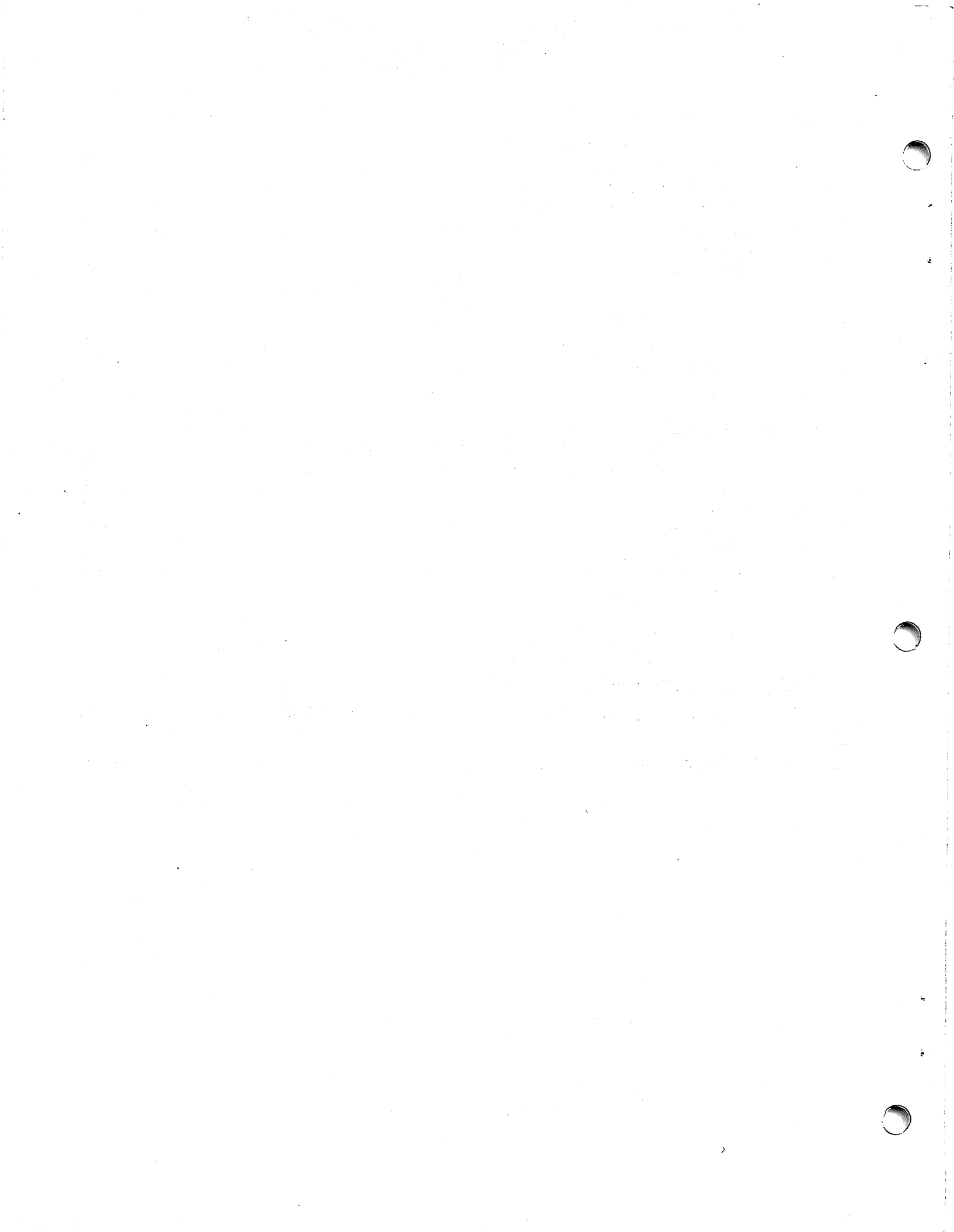

Chapter 1

Introduction

INTRODUCTION

The Model 2232B Digital Flatbed Plotter provides continuous line or point plotting of curves and data. It also provides full alphanumeric labeling of plots. Circle charts, bar graphs, subdivisional plans and highway plans may be plotted. The Model 2232B uses any kind of paper, including linen, vellum, and mylar and has the option of using fiber tip, ball point, or drafting pens.

The Plotting table measures 60 $\frac{1}{4}$ " (153.04 cm) x 46" (116.84 cm); the actual plotting surface is 48" (121.92 cm) x 31" (78.74 cm). Smaller plots may be positioned anywhere within the plotting surface boundaries.

Alphanumeric character generation is not built into the Model 2232B, but is provided by software.

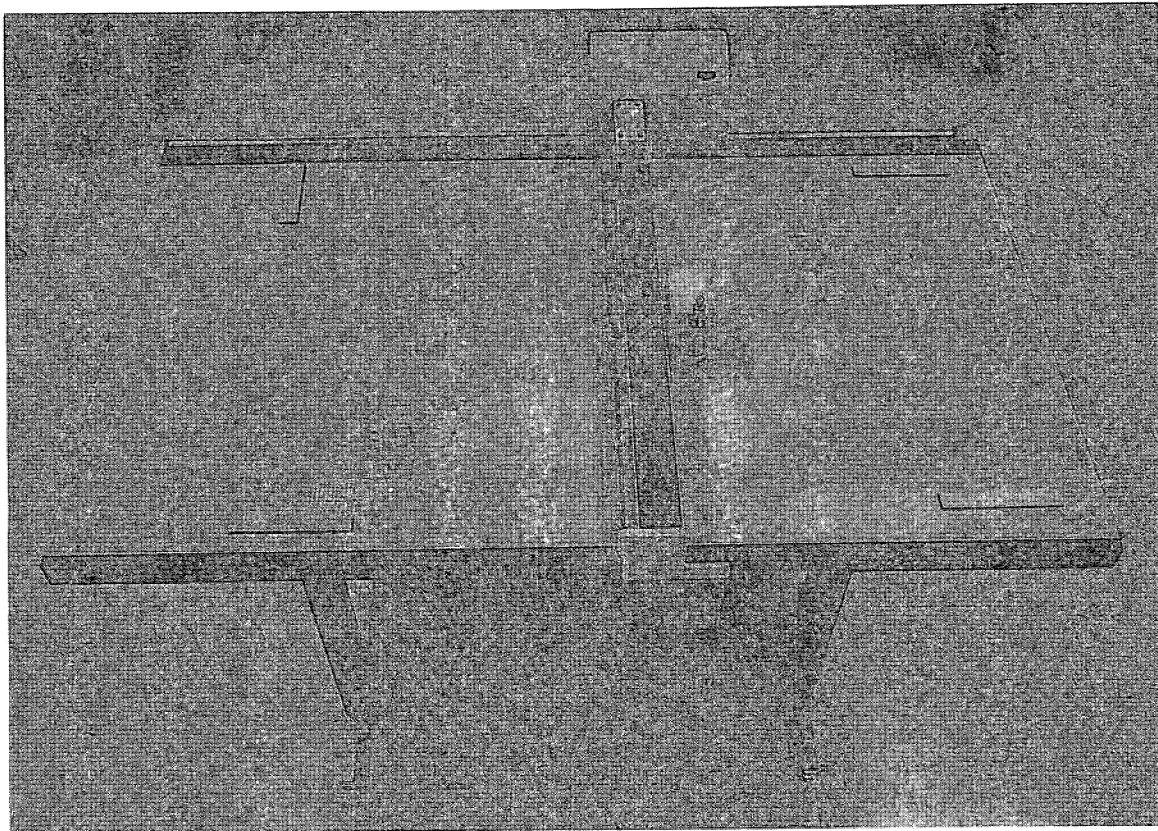

CHAPTER 1 – INTRODUCTION

UNPACKING AND PACKING INSTRUCTIONS

When installing or replacing a Model 2232B plotter, do not destroy the packing material. Do not discard the packing material until a full checkout procedure has been performed.

To install a plotter, lay the carton containing the table and arm flat on the floor with the arrows pointing up. Remove the package tapes and cover. Remove the top layer of Instapak foam; this will reveal the plotting table. With the aid of another person lift the table vertically from the carton. If no clamps are to be installed simply lay the plotting table on your table with the gearfence extending over one edge approximately three inches.

There are two shipping clamps on the Model 2232B. One is in the X rail of the table which keeps the arm forced against the right margin of the table. The wooden clamp is held by a bolt through its center. Loosen this bolt and then slide the clamp to left until it leaves the X rail. The other wooden clamp is at the opposite end of the arm. It also forces the arm against the right margin of the table. It is to the left of the arm clamped around the X gearfence. To remove it, loosen the bolt in the center of the block and pull the block away from the gearfence. See illustration below for clamp location. For packing a Model 2232B, reverse the above procedure.

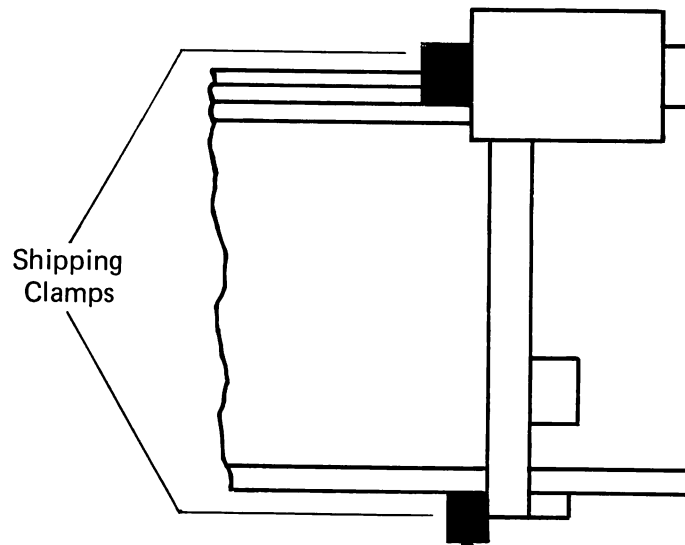

INSTALLATION PROCEDURE

1. Plug in the peripheral connectors to the peripheral board located in the CPU. All peripheral boards are labeled (2216, 2222, etc.)
2. Plug in the electronic package to the Model 2232B Flatbed Plotter.

CABLE ATTACHES
TO CONNECTOR
ON THE BOTTOM
OF THE MOTOR
CASTING

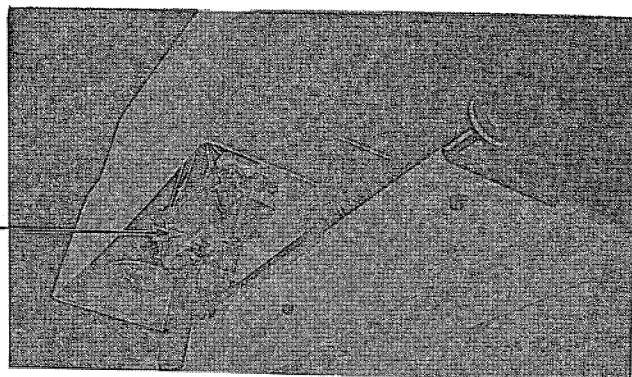

Connecting Package Cable to Plotting Table

CHAPTER 1 – INTRODUCTION

3. Plug in power cords for all peripherals.
4. Plug in power connector of CPU to power supply unit.
5. Plug in connector of power supply unit to power source.

POWER ON PROCEDURE

1. Turn power switches ON for all peripherals, including the CRT.
2. Move the main switch on the Power Supply to the ON position (light on the Power Supply illuminates). This step Master Initializes the System 2200.

Paper – Any type of paper may be used along with linen, vellum and mylar.

Pens – Various types of pens are usable including rapidograph, fiber tip, Esterbrook's Vega Pen with Synaflex tips and ballpoint pen (Lindy).

PREVENTIVE MAINTENANCE PROCEDURES

The Model 2232B should have visual and performance checks, and lubrication at least three (3) times annually.

LUBRICATION

The X shaft should be lubricated after being cleaned with a light coat of silicon grease.

CLEANING

Clean the X shaft by wiping it with a cloth or paper towel.
Do not moisten the towel.

Remove any dust or foreign material from the X rail.

Check for any loose components, screws or bolts.

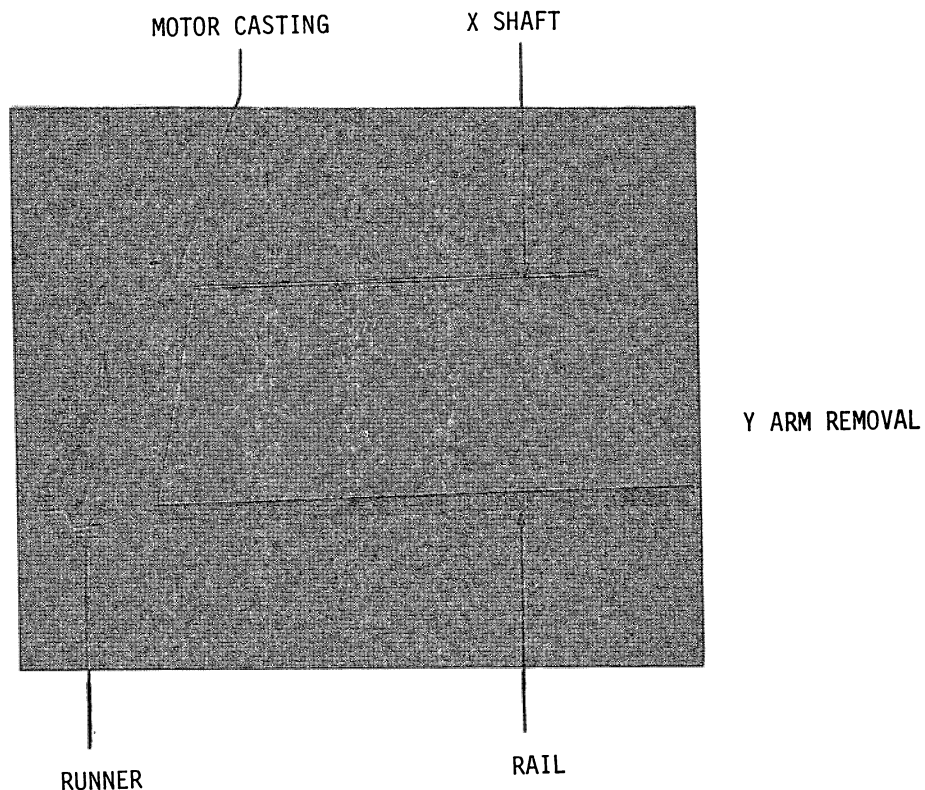

CHAPTER 1 – INTRODUCTION

SQUARING X SHAFT

The rack should be parallel to the edge of the X shaft over 10" to within 0.002" and a maximum of 0.005" over the entire length of the rack.

To adjust this, loosen the 6 screws directly beneath the X shaft and move the shaft to the specified position. See Figure 1 .

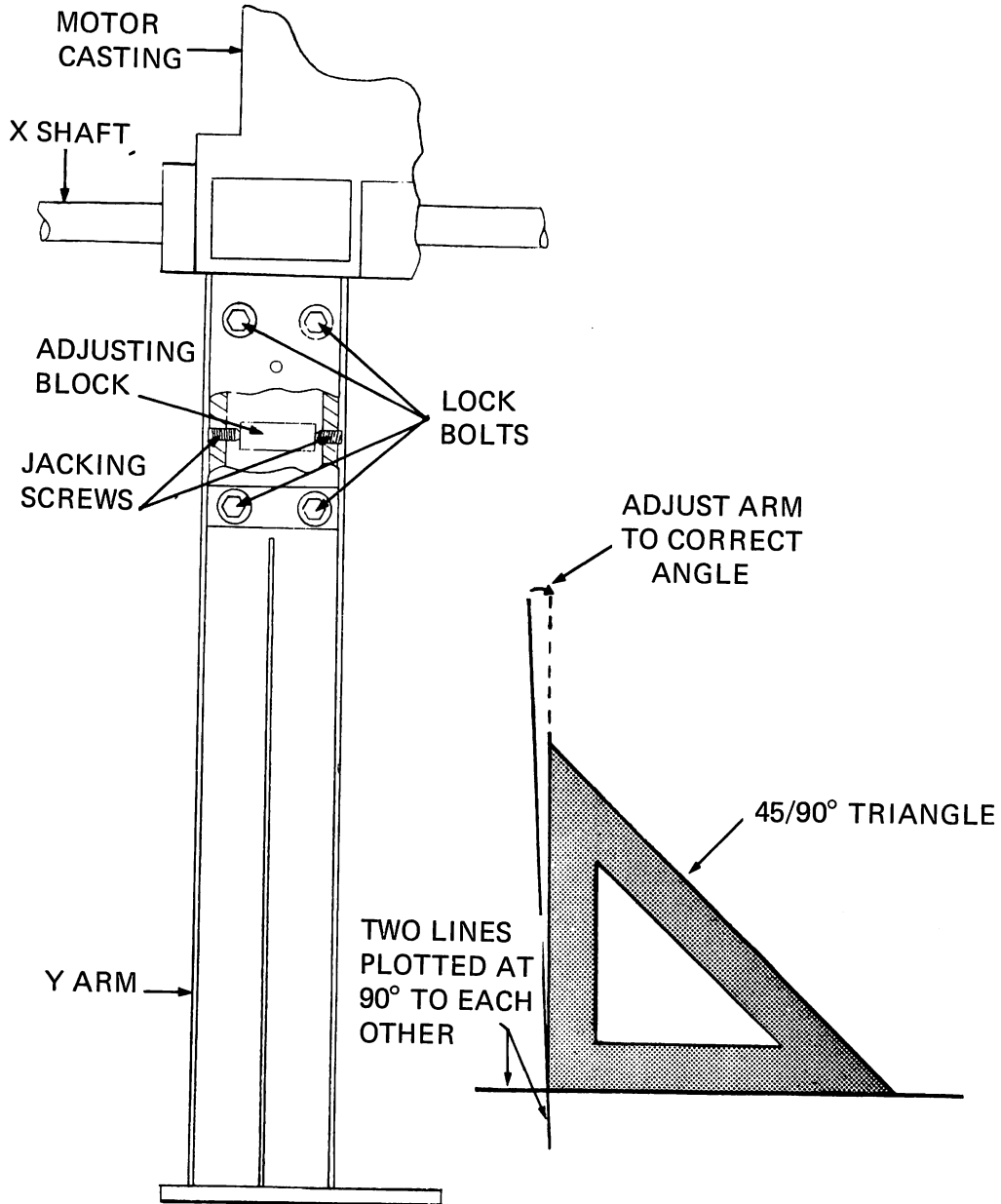

Figure 1. Plotting Arm

MAKING Y ARM PERPENDICULAR TO THE X SHAFT

The Y arm must be square to the X shaft within 0.010" over a 30" length. This is checked with a large triangle placed on a 90° plot as shown in Figure 1 . The trial plot may be generated by subroutine 0014 on tape #8560.

To adjust the Y arm, loosen the lock bolts on the motor casting where it connects to the Y arm, and shift the adjusting block by loosening one jacking screw and tightening the other. See Figure 1 .

Chapter 2

Plot Statements

SELECTING THE MODEL 2232B

The Device Address for the Model 2232B is factory set at 413. All PLOT statements and commands operate directly on a Model 2232B with a Device Address of 413; selecting is unnecessary (i.e., a System 2200 PLOT command will assume an address of 413 if no other address has been selected). However, a few Model 2232A Plotters were shipped with the Device Address set at 414. Check your 2232B Plotter Controller Board. If the address is 414, the Plotter can be activated by the following procedure:

1. Master Initialize the System 2200.
2. Place the Model 2232B POWER switch in the ON position.
3. Key in SELECT PLOT 414 on the Keyboard.
4. SELECT PLOT 414 must be keyed in each time the System 2200 or the Model 2232B is turned OFF, then ON again.

At customer request, your Wang Service Representative can change a controller board with a Device Address of 414 to 413.

PLOTTING INCREMENTS

The Model 2232B is a digital plotter which plots in multiples of discrete steps or increments. The size of a plotter increment is 0.0025 inch (0.0064 cm). There are exactly 400 plotter increments per inch. When a PLOT statement is issued, it always instructs the plotter to plot or move a specified number of plotter increments along the X and Y axes, relative to its present position. For example, the statement PLOT (200, 400, D) instructs the plotter to plot a line, starting at its current position, to a point 200 increments (½ inch) on the X axis, and 400 increments (1 inch) on the Y axis. The dimensions of the physical plotting surface are 48" x 31". Thus, there are a total of 48 x 400, or 19,200, increments on the X axis, and 31 x 400, or 12,400, increments on the Y axis.

ROUND-OFF ERROR

When programming the System 2200 to plot, round-off error must be taken into account. If a curve is being plotted, either the ΔX or ΔY increments, or both, are not generally integer values. Since the plotter can accept only integer values, the increments must be rounded off to the nearest integer value. The fractional differences between the actual and rounded increments should then be saved and added into the next increments. This procedure must be repeated for all successive points in the curve.

PLOT

General Form:

$$\text{PLOT [expression 0] < [expression 1], [expression 2], \left. \begin{array}{c} \text{'null'} \\ \text{U} \\ \text{D} \\ \text{R} \end{array} \right\} > [, < \dots]$$

where: expression 0 represents the replication factor, or the number of times the values enclosed in < > are plotted
($1 \leq \text{expression 0} < 1000$)

If omitted, expression 0 is assumed to be 1.

expression 1 represents Δx increments of .0025"
($-1000 < \text{expression 1} < 1000$)

If omitted, expression 1 is assumed to be 0.

expression 2 represents Δy increments of .0025"
($-1000 < \text{expression 2} < 1000$)

If omitted, expression 2 is assumed to be 0.

All 3 expressions are truncated to integer values.

For Plotting

'null' (i.e., no argument) and U imply move the Δx and Δy distance, specified in expression 1 and expression 2, with the pen up.

D implies draw a line while moving the Δx and Δy distance specified in expression 1 and expression 2.

R (RESET) moves the pen to the zero position on the plotter.

Purpose

When used with plot arguments this statement moves the plot pen from its current position to a position a distance x (expression 1; to the right if positive, to the left if negative) and y (expression 2; up if positive, down if negative) from the current position. The movement can be made with the pen up (U, 'null') or down (D).

One additional plotter control argument is available. R resets the plotter to the 0,0 position with the pen up.

Examples:

Moving the plot pen

PLOT < 10, 20, D > Plot (pen down) moving $\Delta x = 10$ (times .0025") and $\Delta y = 20$ (times .0025").

PLOT < A, B, U > Advance (pen up) $\Delta x = \text{integer value of A}$ (times .0025") and $\Delta y = \text{integer value of B}$ (times .0025")

PLOT < , , R > Reset to 0,0 position

Replication and multiple arguments on one line

10 PLOT 10 < X, Y, D > Plot x and y 10 times

10 N = 30 Advance $\Delta x = -10$ and $\Delta y = 20$ thirty times

20 PLOT N < -10, 20, U >

10 PLOT < X, Y, U >, < 10, 20, D >, < A + 10, -B, U >, < , , R >

The above is an example of multiple arguments in one PLOT statement. They are processed sequentially from left to right.

APPENDIX A – MODEL 2232B ACCESSORIES

STANDARD EQUIPMENT ENCLOSED WITH EACH MODEL 2232B

ITEM	PART NUMBER
1 pen stand	478-0257
1 ball point pen housing	279-0083
1 ink pen housing	279-0084
1 fiber tip pen housing	279-0085
1 black ball point pen	725-0471-0
1 plotting point MARS #757-PL3-C3	725-0464-0
1 package of 5 black fiber tip pens	725-0466-0
1 8 oz. bottle black ink MARS #747-25T	725-0467
1 8 oz. bottle pen cleaner MARS #746-25	725-0466
6 magnets	458-0198
6 plates (for magnets)	660-0508

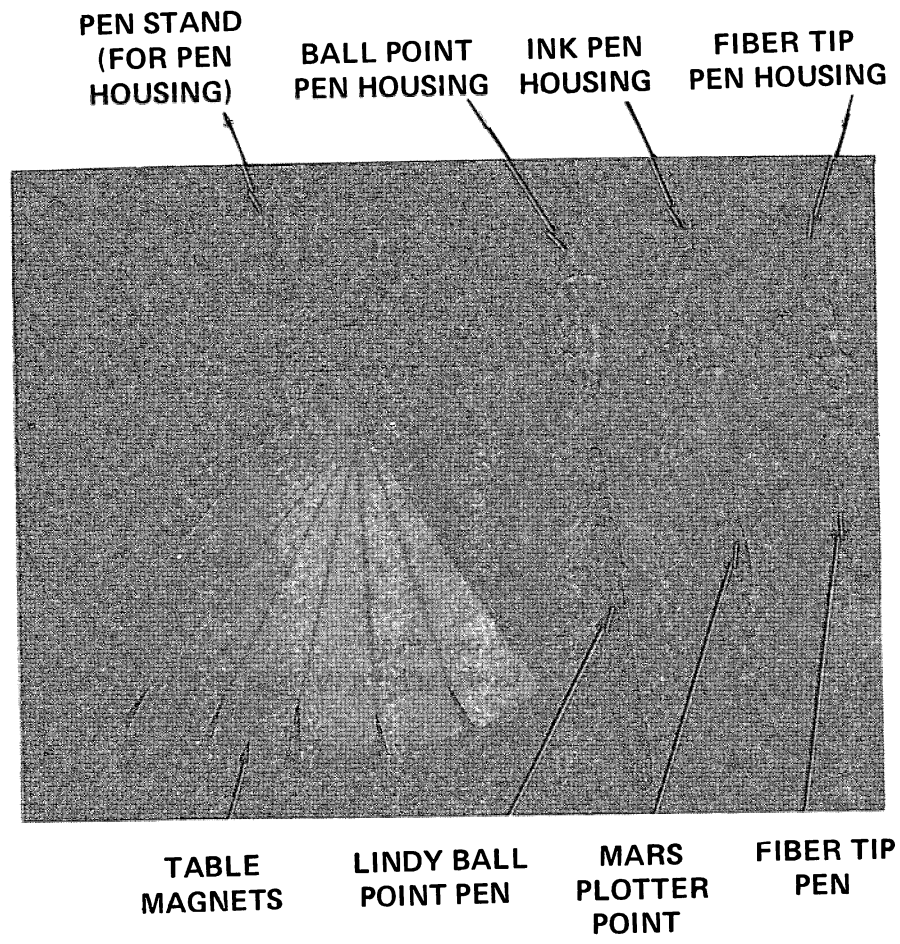

Accessories to Model 2232A

APPENDIX A – MODEL 2232B ACCESSORIES

OPTIONAL PACKAGE OF ACCESSORY EQUIPMENT FOR THE MODEL 2232B

ITEM	PART NUMBER
1 ball point pen - black	725-0471-0
1 ball point pen - blue	725-0471-6
1 ball point pen - red	725-0471-2
1 fiber tip plotter point - black	725-0466-0
1 fiber tip plotter point - blue	725-0466-6
1 fiber tip plotter point - red	725-0466-2
1 MARS 746 25, 8 oz. bottle pen cleaner	725-0466
1 MARS plotter point 757-PL2C3, size 00	725-0464-00
1 MARS plotter point 757-PL3C3, size 0	725-0464-0
1 MARS plotter point 757-PL4C3, size 1	725-0464-1
1 MARS plotter point 757-PL5C3, size 2	725-0464-2
1 MARS plotter point 757-PL6C3, size 2.5	725-0464-25
1 MARS plotter point 757-PL8C3, size 3	725-0464-3
1 MARS plotter point 757-PL10C3, size 3.5	725-0464-35
Plastic Ink Cartridge and Holder (MARS 700)	725-0465-9
1 MARS 747 25T, 8 oz. black ink	725-0467
1 MARS 745 25T, 2/3 oz. blue ink	725-0469
1 MARS 745 25T, 2/3 oz. red ink	725-0468

All of the items listed under standard or accessory equipment are stocked in General Services (c/o Wang Laboratories, Lowell, MA.). Any single item may be purchased by specifying the correct part number; please see your Wang salesman for prices.

PAPER RECOMMENDATIONS

1. Paper - Opaque
2. Tracing Paper - 100% Rag Vellum
3. Mylar - Formulated for ink
 - a. Suggest for minimum pen wear
Dupont Cronaflex Drafting Film (VC-4 & VC-7).
4. Acetate - Treated for ink

APPENDIX A – MODEL 2232B ACCESSORIES

INK RECOMMENDATIONS

The following inks are recommended for use with the Model 2232B :

1. Black ink, 8 oz. bottle, MARS 747-25T (Wang part number = 725-0467).
2. Blue ink, 2/3 oz. bottle, MARS 745-25T (Wang part number = 725-0469).
3. Red ink, 2/3 oz. bottle, MARS 745-25T (Wang part number = 725-0468).

Different types and qualities of ink are available at most drafting supply houses and are supplied by:

Staedtler - MARS Ink
P.O. Box 68
1 Mars Court
Montville, New Jersey 07045
Phone 201-335-1800

NOTE:

- a) *Some variables that effect quality of line are paper, ink, humidity and speed of machine.*
- b) *Other inks can be tried to see if line is of higher quality.*
- c) *Waterproof ink tends to clog more readily than non-waterproof ink.*

PLOTTER POINTS

The points recommended for use with the Model 2232B are provided by the MARS plotter point series, 750-PL3-C3 (Wang part number = 725-0465-0).

CARE AND CLEANING

1. Recommend MARS 746 25 pen cleaner (Wang part number = 725-0466) for plotter points.
2. Replace cap on all pens to insure remaining ink in pen will not dry.

PEN PRESSURE ADJUSTMENT

1. Turn pen pressure adjustment screw clockwise to increase pen pressure and c'lockwise to decrease pressure.
2. Check pen to see it is not clogged or dried up.
3. Test pen over entire plotting area to insure that pen will write properly.

PEN HEIGHT ADJUSTMENT

1. Turn pen height adjustment screw clockwise to raise pen and c'lockwise to lower pen.
2. Pen should be adjusted high enough to avoid hitting paper holddown magnet, and still be able to plot over the entire area when it is actuated.

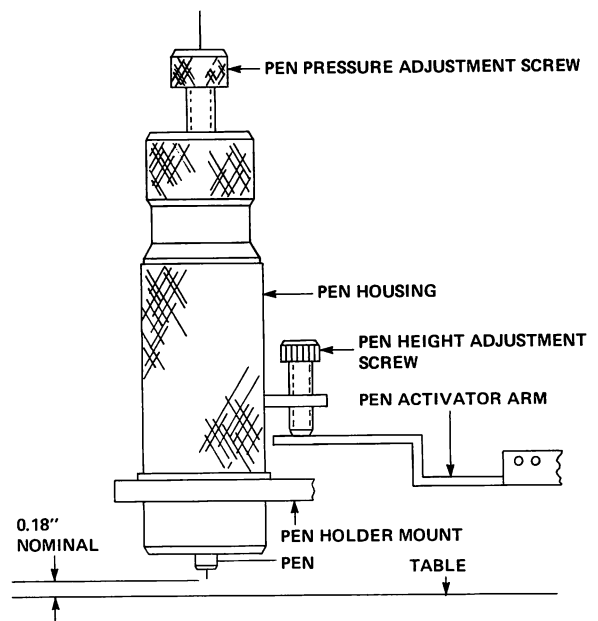

APPENDIX A – MODEL 2232B ACCESSORIES

LOADING PROCEDURE FOR BALL PEN

1. Turn locking cap to position where grooved hole in locking cap lines up with hole in inner sleeve.
2. Insert ball pen so as it bottoms on inner sleeve.
3. Turn locking cap in either direction till grooved hole in cap locks ball pen in position.
4. Screw preloading cap assembly to pen housing.

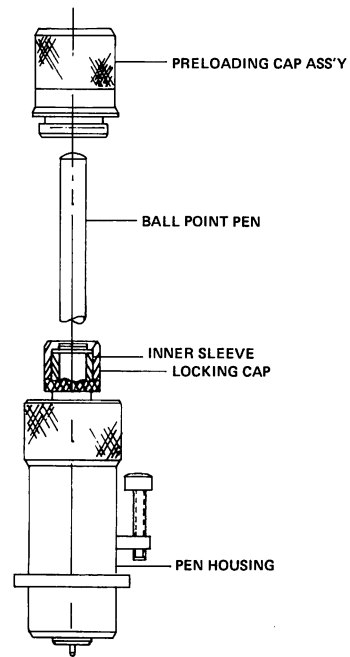

LOADING PROCEDURE FOR INK PEN

1. Lift adaptor sleeve from pen housing – screw plotter point into point holder – screw point holder assembly into adaptor sleeve.
2. Load pen slide assembly in pen housing so that pen point protrudes through hole at point "A"
3. Screw preloading cap assembly to pen housing.

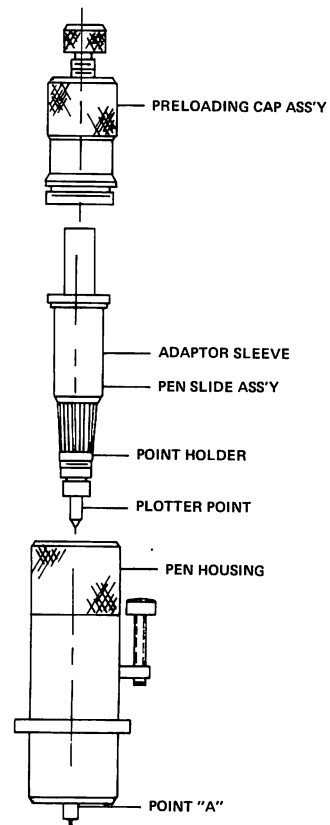

APPENDIX A – MODEL 2232B ACCESSORIES

LOADING PROCEDURE FOR FIBER PEN

1. Push fiber pen into inner sleeve of pen housing until it bottoms.
2. Screw preloading cap assembly to pen housing.

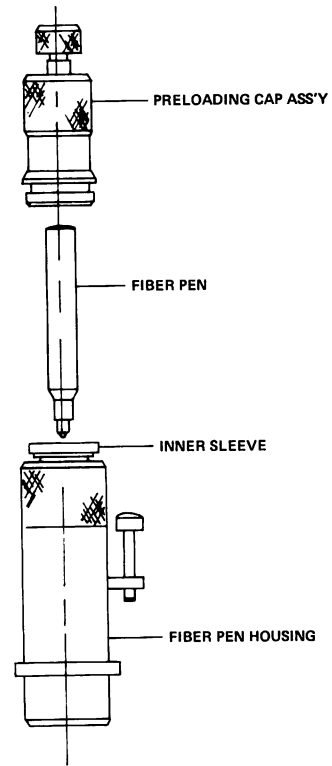

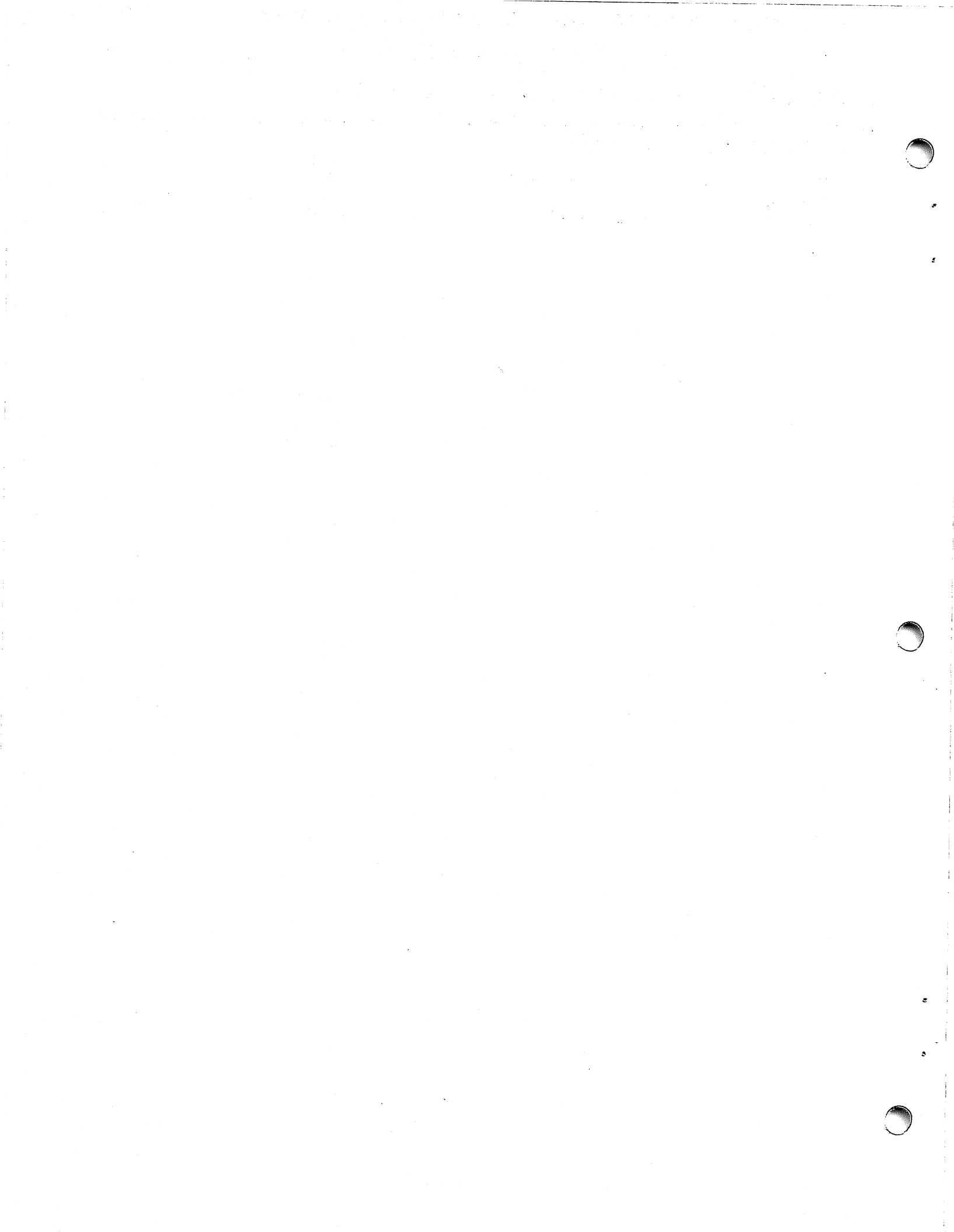

APPENDIX B – MODEL 2232B SPECIFICATIONS

SPECIFICATIONS*

Paper Capacity

59½ inches (151.13 cm) x 36 inches (91.44 cm)

Plotting Area

48 inches (121.92 cm) x 31 inches (78.74 cm)

Plotting Accuracy and Repeatability

± (0.01 inches + 0.001 inch/inch)

± (0.0254 cm + 0.001 cm/cm)

Stepping Increments:

0.0025 inch (0.00635 cm) per step, max. 999 steps

Stepping Rate

300 to 500 steps/sec

Plotting Speed

60 inches/min (152.4 cm/min) average; depends on processing time required by controlling program.

Operating Environment

50° F to 104° F (10° C to 40° C)

30% to 80% relative humidity

Size – Table

Height	9½ inches (24.130 cm)
Width	60¼ inches (153.035 cm)
Depth	46 inches (116.840 cm)
Net Weight	112 lbs (50.08 kg)

Size – Control Unit

Height	19 inches (48.260 cm)
Width	18 inches (45.720 cm)
Depth	10 inches (25.400 cm)
Net Weight	30 lbs (13.60 kg)

Power Requirements

Voltage: 115 VAC or 230 VAC ± 10%

50 or 60 Hz ± 1 cps

Power: 175 Watts

Fuses: 2A @ 115V

2A @ 230V

Connecting Cables

10- ft (3m) cable from plotter control unit to CPU connection.

10- ft (3m) cable from plotter control unit to plotter arm.

8- ft (2.4m) cord from plotter control unit to AC power source.

*A metric version of the Digital Flatbed Plotter is designated as Model 2232 BM. Its physical and operating characteristics are identical to the Model 2232B except that it has a stepping increment of 0.05 mm (200 plotting increments per cm).

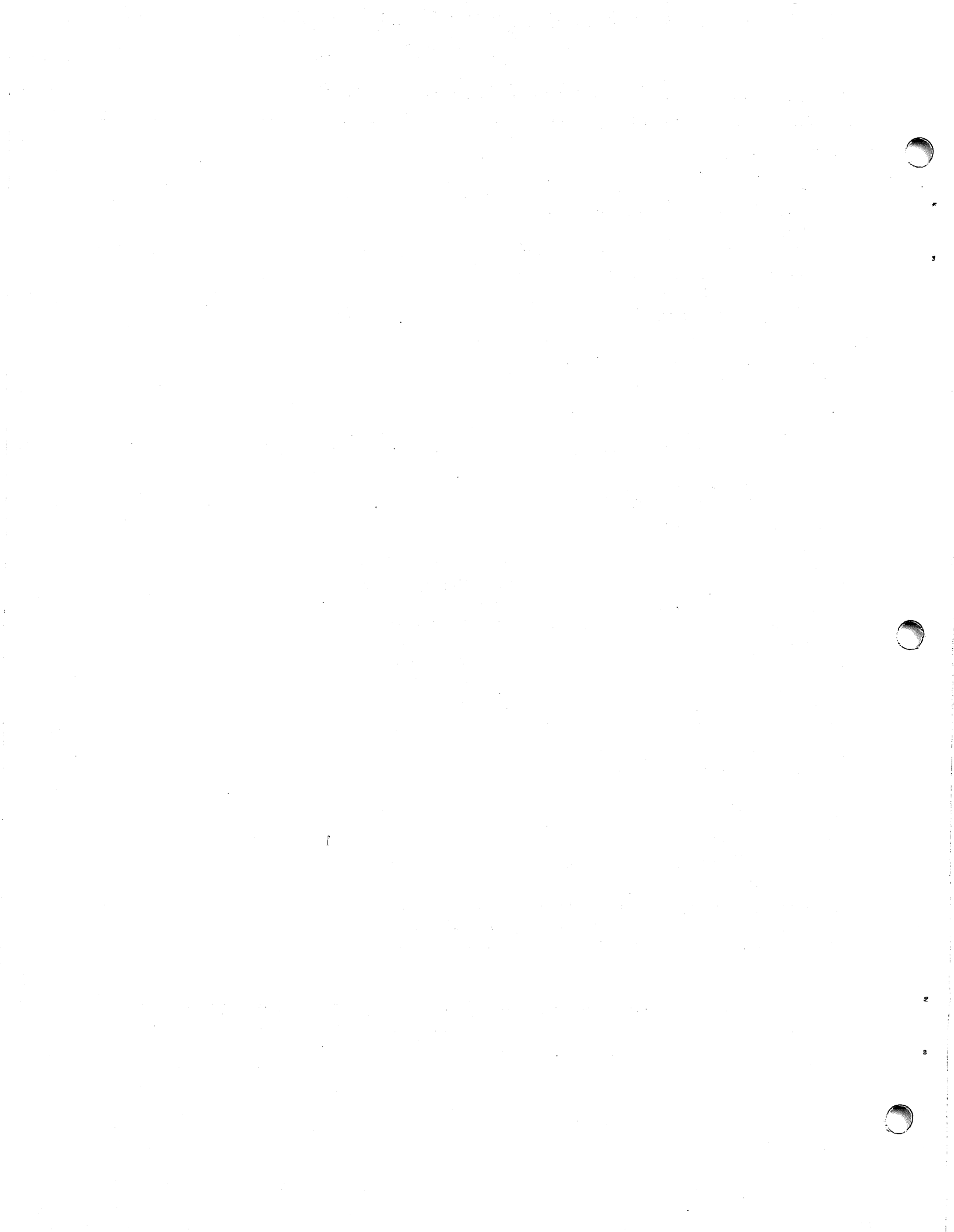

APPENDIX C – EQUIPMENT GUARANTEE AND MAINTENANCE AGREEMENT

GUARANTEE

The Model 2232B is guaranteed from defects in materials and workmanship for a period of ninety days (one year for State and Federal Governments).

MAINTENANCE

It is recommended that the Model 2232B be serviced Semi-Annually. A Maintenance Agreement is available to automatically assure this servicing. If no Maintenance Agreement is acquired, any servicing must be arranged for by the customer. A Maintenance Agreement protects your investment and offers the following benefits:

Preventive Maintenance: Semi-Annually, your Model 2232B is inspected for worn parts, lubricated, cleaned and updated with engineering changes, if any. Preventive maintenance minimizes "downtime" by anticipating repairs before they are necessary.

Fixed Annual Cost: When you buy a Maintenance Agreement, you issue only one purchase order for service for an entire year and receive one annual billing, or, more frequent billing if desired.

Further information regarding Maintenance Agreement can be acquired from your local Sales Service Office.

NOTE:

Wang Laboratories, Inc. will not guarantee or honor Maintenance Agreements for any equipment modified by the user. Damage to equipment incurred as a result of this will be the financial responsibility of the user.

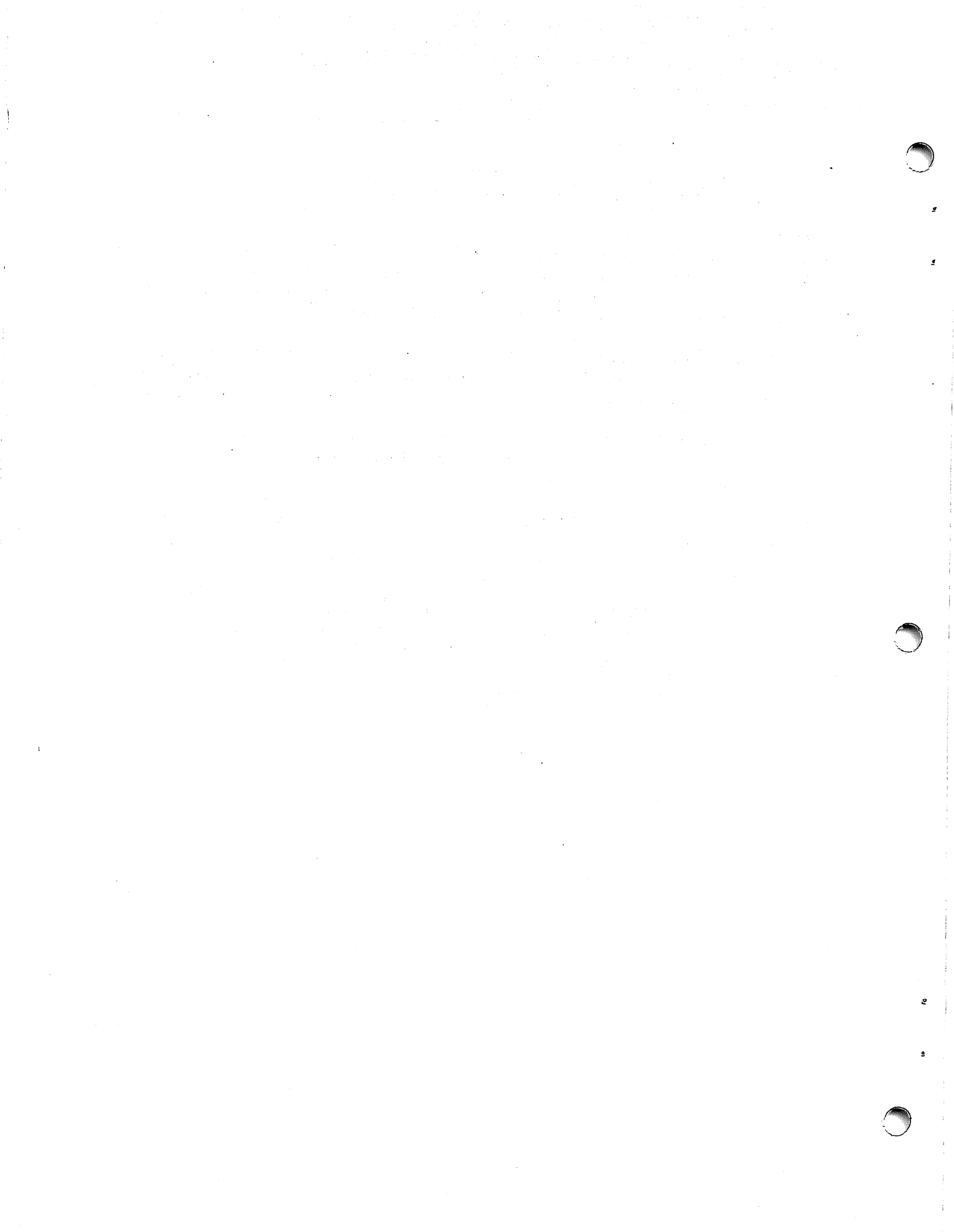

INDEX

Accessories of the Model 2232B	7	Paper Recommendations	8
Care and Cleaning	9	Pen Height Adjustment	9
Cleaning	3	Pen Pressure Adjustment	9
Ink Recommendations	9	PLOT	6
Installation Procedure	2	Plot Statements	5
Introduction	1	Plotter Points	9
Loading Procedure for Ball Pen	10	Power On Procedure	3
Loading Procedure for Ink Pen	10	Preventive Maintenance Procedures	3
Loading Procedure for Fiber Pen	11	Round-off Error	5
Lubrication	3	Selecting the Model 2232B	5
Making Y Arm Perpendicular to the X Shaft	4	Specifications	13
		Squaring X Shaft	4
		Unpacking and Packing Instructions	2



g

v



e

s



To help us to provide you with the best manuals possible, please make your comments and suggestions concerning this publication on the form below. Then detach, fold, tape closed and mail to us. All comments and suggestions become the property of Wang Laboratories, Inc. For a reply, be sure to include your name and address. Your cooperation is appreciated.

700-3371B

TITLE OF MANUAL: 2232B DIGITAL FLATBED PLOTTER REFERENCE MANUAL

COMMENTS:

Fold

Fold



Fold

FIRST CLASS
PERMIT NO. 16
Tewksbury, Mass.

BUSINESS REPLY MAIL
NO POSTAGE STAMP NECESSARY IF MAILED IN THE UNITED STATES

— POSTAGE WILL BE PAID BY —

WANG LABORATORIES, INC.
ONE INDUSTRIAL AVENUE
LOWELL, MASSACHUSETTS 01851

Cut along dotted line.

Attention: Technical Writing Department

Fold

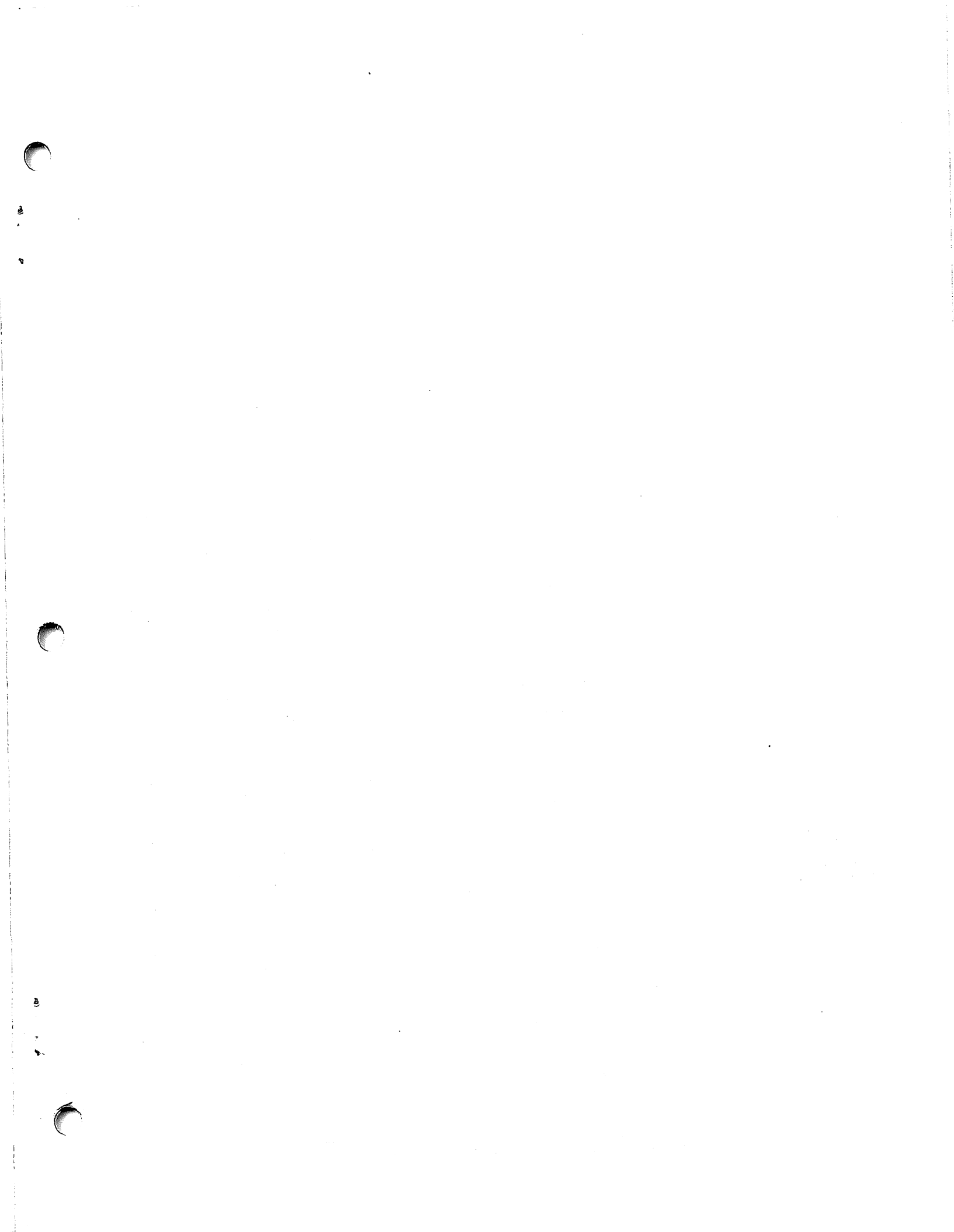

WANG COMPUTER PTY. LTD.

55 Herbert Street
St. Leonards, 2065, Australia
TELEPHONE 439-3511
Telex: 25469

WANG GESELLSCHAFT M.B.H.

Merlingengasse 7
A-1120 Vienna, Austria
TELEPHONE 85.85.33
Telex: 74640 Wang a

WANG EUROPE S.A./N.V.

250, Avenue Louise
1050 Brussels, Belgium
TELEPHONE 02/6400617
Telex: 61186

**WANG DO BRASIL
COMPUTADORES LTDA.**

Rua Barao de Lucena No. 32
Botafogo ZC-01 20,000
Rio de Janeiro RJ, Brasil
TELEPHONE 226-4326, 266-5364
Telex: 2123296 WANG BR

**WANG LABORATORIES
(CANADA) LTD.**

49 Valleybrook Drive
Don Mills, Ontario M3B 2S6
TELEPHONE (416) 449-2175
Telex: 069-66546

WANG FRANCE S.A.R.L.

Tour Gallieni, 1
78/80 Ave. Gallieni
93170 Bagnolet, France
TELEPHONE 33.1.3602211
Telex: 680958F

WANG PACIFIC LTD.

9th Floor, Lap Heng House
47-50 Gloucester Road
Hong Kong
TELEPHONE 5-274641
Telex: 74879 WANG HX

WANG COMPUTER LTD.

Shindaiso Building No. 5
2-10-7 Dogenzaka Shibuya-Ku
Tokyo 150, Japan
TELEPHONE (03) 464-0644
Telex: 2424909WCLTKO J

WANG NEDERLAND B.V.

Damstraat 2
Utrecht, Netherlands
(030) 93-09-47
Telex: 47579

WANG COMPUTER LTD.

302 Great North Road
Grey Lynn, Auckland
New Zealand
TELEPHONE Auckland 762-219
Telex: CAPENG 2826

WANG DE PANAMA (CPEC) S.A.

Apartado 6425
Calle 45E, No. 9N. Bella Vista
Panama 5, Panama
TELEPHONE 69-0855, 69-0857
Telex: 3282243

WANG COMPUTER PTE., LTD.

Suite 1801-1808, 18th Floor
Tunas Building, 114 Anson Road
Singapore 2, Republic of Singapore
TELEPHONE 2218044, 45, 46
Telex: RS 24160 WANGSIN

**WANG COMPUTERS
(SO. AFRICA) PTY. LTD.**

Corner of Allen Rd. & Garden St.
Bordeaux, Transvaal
Republic of South Africa
TELEPHONE (011) 48-6123
Telex: 960-86297

WANG SKANDINAVISKA AB

Pyramidvaegen 9A
S-171 36 Solna, Sweden
TELEPHONE 08/27 27 98
Telex: 11498

WANG S.A./A.G.

Markusstrasse 20
CH-8042 Zurich 6, Switzerland
TELEPHONE 41-1-60 50 20
Telex: 59151

WANG INDUSTRIAL CO., LTD.

7 Tun Hwa South Road
Sun Start Tun Hwa Bldg.
Taipei, Taiwan
Republic of China
TELEPHONE 7522068, 7814181-3
Telex: 21713

WANG ELECTRONICS LTD.

Argyle House, 3rd Floor
Joel Street
Northwood Hills
Middlesex, HA61NS
TELEPHONE Northwood 28211
Telex: 923498

WANG LABORATORIES GmbH

Moselstrasse 4
6000 Frankfurt AM Main
West Germany
TELEPHONE (0611) 252061
Telex: 04-16246

DATA CENTER DIVISION

20 South Avenue
Burlington, Massachusetts 01803
TELEPHONE (617) 272-8550

WANG COMPUTER SERVICES

One Industrial Avenue
Lowell, Massachusetts 01851
TELEPHONE (617) 851-4111
TWX 710-343-6769
Telex: 94-7421

**WANG INTERNATIONAL
TRADE, INC.**

One Industrial Avenue
Lowell, Massachusetts 01851
TELEPHONE (617) 851-4111
TWX 710-343-6769
Telex: 94-7421

WANG

LABORATORIES, INC.

ONE INDUSTRIAL AVENUE, LOWELL, MASSACHUSETTS 01851, TEL. (617) 851-4111, TWX 710 343-6769, TELEX 94-7421

Printed in U.S.A.

700-3371B

5-77-5C

Price: see current list