

EDITED BY CUSTOMER ENGINEERING DIVISION

2236 INTERACTIVE TRANSACTION TERMINAL

LOOPBACK CONNECTION
2-3 4-5 6-20

1.1 GENERAL

1.1.1 2236 TERMINAL

The 2236 Interactive Terminal provides multi-user, single task applications for 2200T and 2200VP Systems. There may be from one to four such terminals in a 2200T System and from one to eight terminals in a 2200VP System. When the 2236 terminal is used in a 2200 System, the standard 2226 User Terminal is normally not used. With the exception of the Console Input/Output Terminal, the 2236 is a 'dumb' non-programmable terminal, able to perform tasks only under program control from the 2200. Any one of the terminals can be selected for Console Input/Output and therefore have programming capabilities, but not more than one terminal at any one time.

Communication to and from the 2200 CPU is via the 2236MXC controller using RS-232-C asynchronous format. Standard rate is 9600 baud, but 4800, 2400, 1200, 600 or 300 baud may be selected.

The 2236 terminal consists of a 12" CRT, 7229 Hall-effect keyboard, 7292 RS-232-C Controller, 7158 CRT/Printer Controller and power supply with 7067 Regulator. The rear panel has a connector for a 21W or 31W printer and an RS-232-C connector for connection to the 2236MXC controller.

NOTICE:

This document is the property of Wang Laboratories, Inc. Information contained herein is considered company proprietary information and its use is restricted solely to the purpose of assisting you in servicing Wang products. Reproduction of all or any part of this document is prohibited without the consent of Wang Laboratories.



LABORATORIES, INC.

1 INDUSTRIAL AVENUE, LOWELL, MASSACHUSETTS 01851. TEL. (617) 851-4111, TWX 710 343-6789, TELEX 94-7421

Printed in U.S.A.
13-210A

Data lines between the 2236MXC and each 2236 terminal are Teletype compatible asynchronous full duplex at any one of the above mentioned baud rates. This type of communication lends itself to remote applications by using modems. Direct cable connection up to 1000 feet at 9600 baud is allowed. Above 1000 feet modems must be used.

1.1.2 2236 MXC CONTROLLER

The 2236MXC is the I/O controller for up to four 2236 terminals. Four RS-232-C connectors are mounted on the 2236MXC for connection to the terminals and/or modems. The Console Input/Output connector is the top connector (viewing the controller face plate with the writing top to bottom). When used with the 2200VP, two four-port interconnected controllers may be installed. Each channel is fully buffered under microprocessor control.

The 2236MXC is controlled by 2200 BASIC routines, known as Terminal Access Method (TAM) subroutines.

1.1.3 TAM SUBROUTINES

The TAM subroutines are incorporated into the user's BASIC program and facilitate polling tasks. The TAM subroutines also allow multiple display prompts and entry fields to appear in a fixed screen form format where the operator "fills in the blanks". Cursor positioning, which allows multiple input fields on a display screen, is also provided by RAM.

1.2 2236 CHASSIS LAYOUT

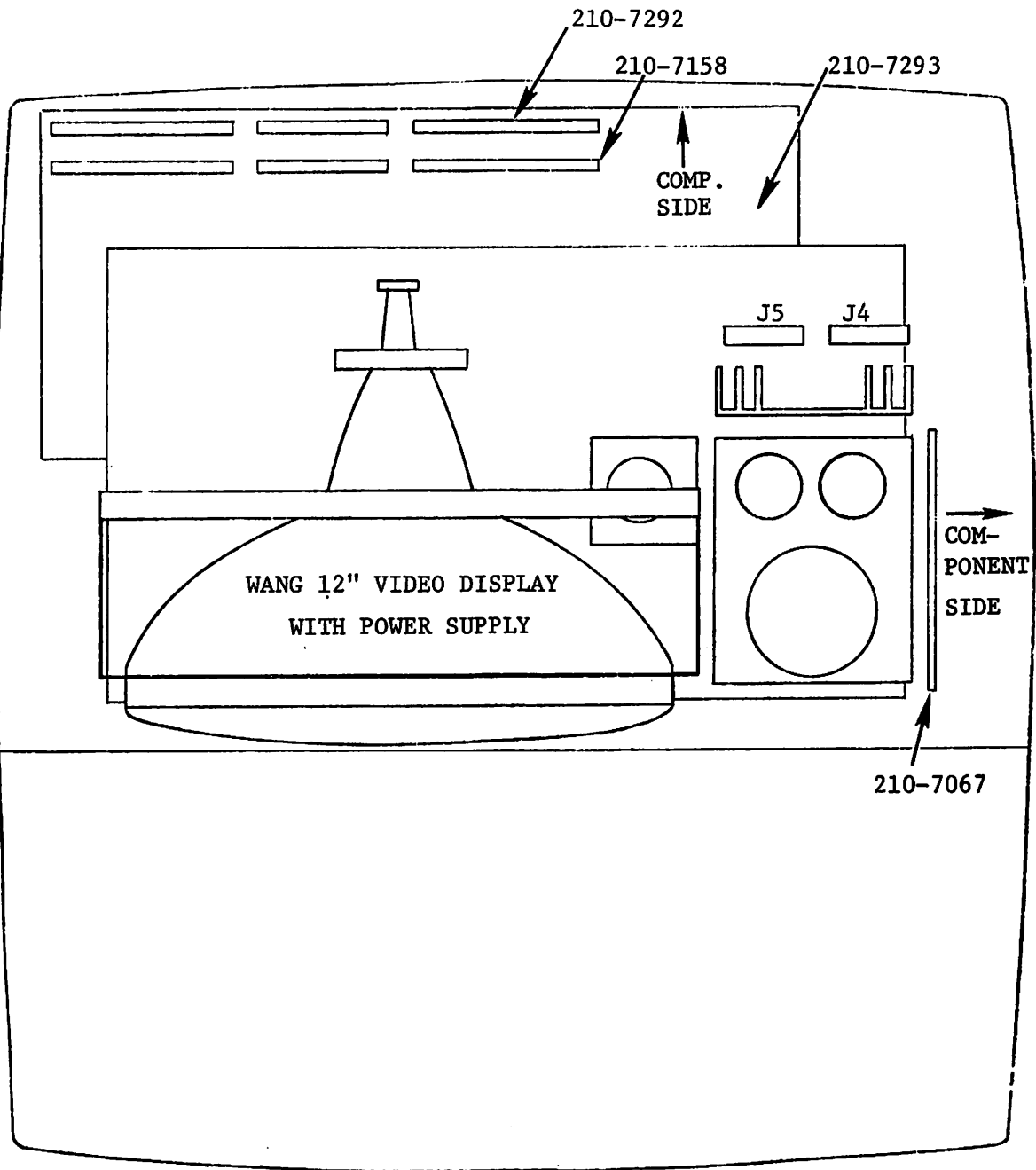

MODEL 2236 CHASSIS LAYOUT

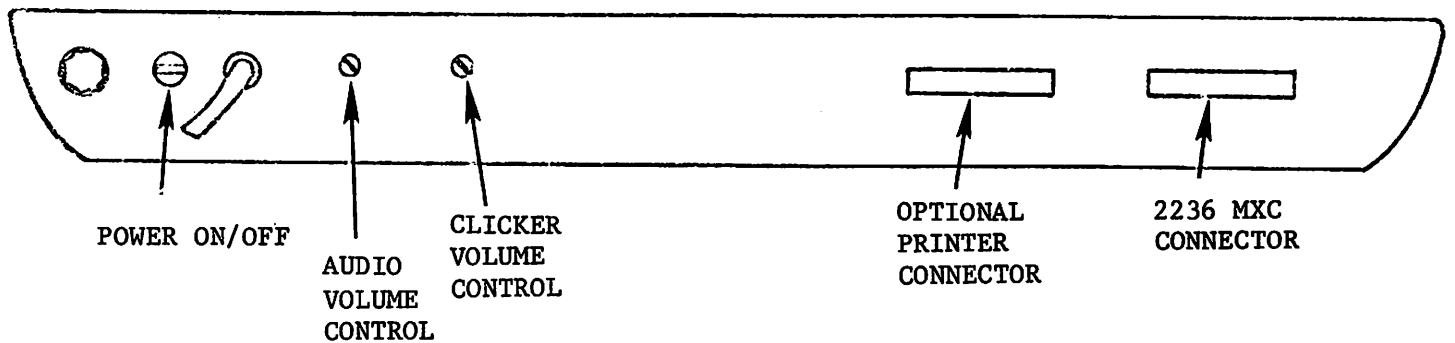

POWER ON/OFF

AUDIO
VOLUME
CONTROL

CLICKER
VOLUME
CONTROL

OPTIONAL
PRINTER
CONNECTOR

2236 MXC
CONNECTOR

MODEL 2236 REAR PANEL

1.2.4 CIRCUIT BOARD SUMMARY

<u>#</u>	<u>Where Used</u>	<u>Description</u>
7067	2236 Terminal	Power Supply Regulator
7292	2236 Terminal	Terminal CPU Electronics
7158	2236 Terminal	Terminal CRT/Printer Controller
7293	2236 Terminal	Motherboard
7229-2	2236 Terminal	Keyboard
7291	2236MXC-1	2236MXC Memory Daughterboard
7290	2236MXC-1	2236MXC Controller Motherboard
7294	2236MXC-2	2236MXC-2 Granddaughter board

1.3 SPECIFICATION

1.3.1 2236 TERMINAL

Size

Height	13 1/2 in. (34.3 cm)
Depth	20 1/2 in. (52 cm)
Width	19 3/4 in. (50.2 cm)

Weight

51 lb (23.1 kg)

CRT

Display Size	12 in. diagonal (30.4 cm)
Capacity	24 lines, 80 characters/line
Character Size	
Height	0.16 in. (0.4064 cm)
Width	0.09 in. (0.2286 cm)

Power Requirements

115 or 230 VAC \pm 10%
50 or 60 Hz \pm 1/2 Hz
40 Watts

Fuses

2.5 a. @ 115V/60 Hz
1.2 a. @ 230V/50 Hz

1.3.2 OPERATING ENVIRONMENT

50 degrees F to 90 degrees F (10 degrees C to 32 degrees C)

20% to 80% relative humidity, allowable

35% to 65% relative humidity, recommended

1.3.3 CABLE

One 8 foot (2.4m) cord to power source. One length of 25 feet (7.6m) direct connection cable is provided with each Model 2236, unless an optional direct connection cable is ordered for that terminal. Cables are optionally available in 100 foot (30.5m) increments for direct connection up to 1,000 feet (304.8m) and are non-extendable. Modem cables are optionally available in lengths of 12 feet (3.7m), with extensions of 25 feet (7.6m) and 50 feet (15.2m); however, combined cable distance from Wang equipment to its modem is 50 ft (15.2m) maximum according to EIA standards.

1.3.4 2236MXC SPECIFICATIONS

Operating Environment

Same as 2200 CPU

Power Requirements

Operates using CPU Power Supply

Communication Modes

Full-Duplex Asynchronous Wang mode for Model 2236's.

Full-Duplex Asynchronous Teletype mode for Teletype-compatible terminals.

Number of I/O Slots Required

Model 2236MXC-1 requires one I/O slot and supports up to four terminals.

Model 2236MXC-2 requires two I/O slots and supports up to eight terminals (2200VP only).

SECTION 2
INSTALLATION

2.1 INCOMING INSPECTION

1. When a 2236 shipment arrives, remove the top cover and check the following:
 - a) The 7256 board is fully inserted into the Wang display chassis.
 - b) The 115V/230V AC line voltage selector switch on the Power Supply module is in the correct position.
 - c) The 115V/230V AC line voltage selector switch on the Display Chassis power supply is in the correct position.
 - d) The DC power cables are securely connected to the motherboard.
 - e) The 7292 and 7158 boards are properly installed in the terminal.

2. Reassemble the 2236, ensuring the fan cable has been reconnected.

2.2 DEVICE ADDRESS ASSIGNMENTS

2.2.1 2236MXC-1

The 2236MXC-1 normally operates at hardwired addresses of 01/05, 02/06, 03/07 and 04/08. If the 2236MXC-1 is installed in a system using a 2226 with addresses of 01 and 05, then the 2236MXC-1 must be set to addresses 81/85, 82/86, etc., by setting one switch on. This switch changes the high order address bit from 0 to 8 and is located on the 7290 controller. Set switch ON for 8 and OFF for 0.

2.2.2 2236MXC-2

None.

2.3 SETTING THE BAUD RATE SWITCHES

2.3.1 2236 TERMINAL

Access to the baud rate switch in the 2236 is through the large plug-button on the rear of the cover. Remove the plug and set the three rightmost switches of the five bank switch as follows (the two leftmost switches are OFF):

Switch:	1	2	3	4	5	Baud Rate
	OFF	OFF	OFF	OFF	OFF	300
	OFF	OFF	OFF	OFF	ON	600
	OFF	OFF	OFF	ON	OFF	1200
	OFF	OFF	OFF	ON	ON	2400
	OFF	OFF	ON	OFF	OFF	4800
	OFF	OFF	ON	OFF	ON	9600

2.3.2 2236MXC-1

There are three 8 bank switches located on the 7290 controller. The three switches are divided into groups of six switches, each group corresponding to a connector on the top panel.

Only one switch in any group of six is ON at any time. Each switch corresponds to a specific baud rate for its corresponding RS-232-C connector, as shown.

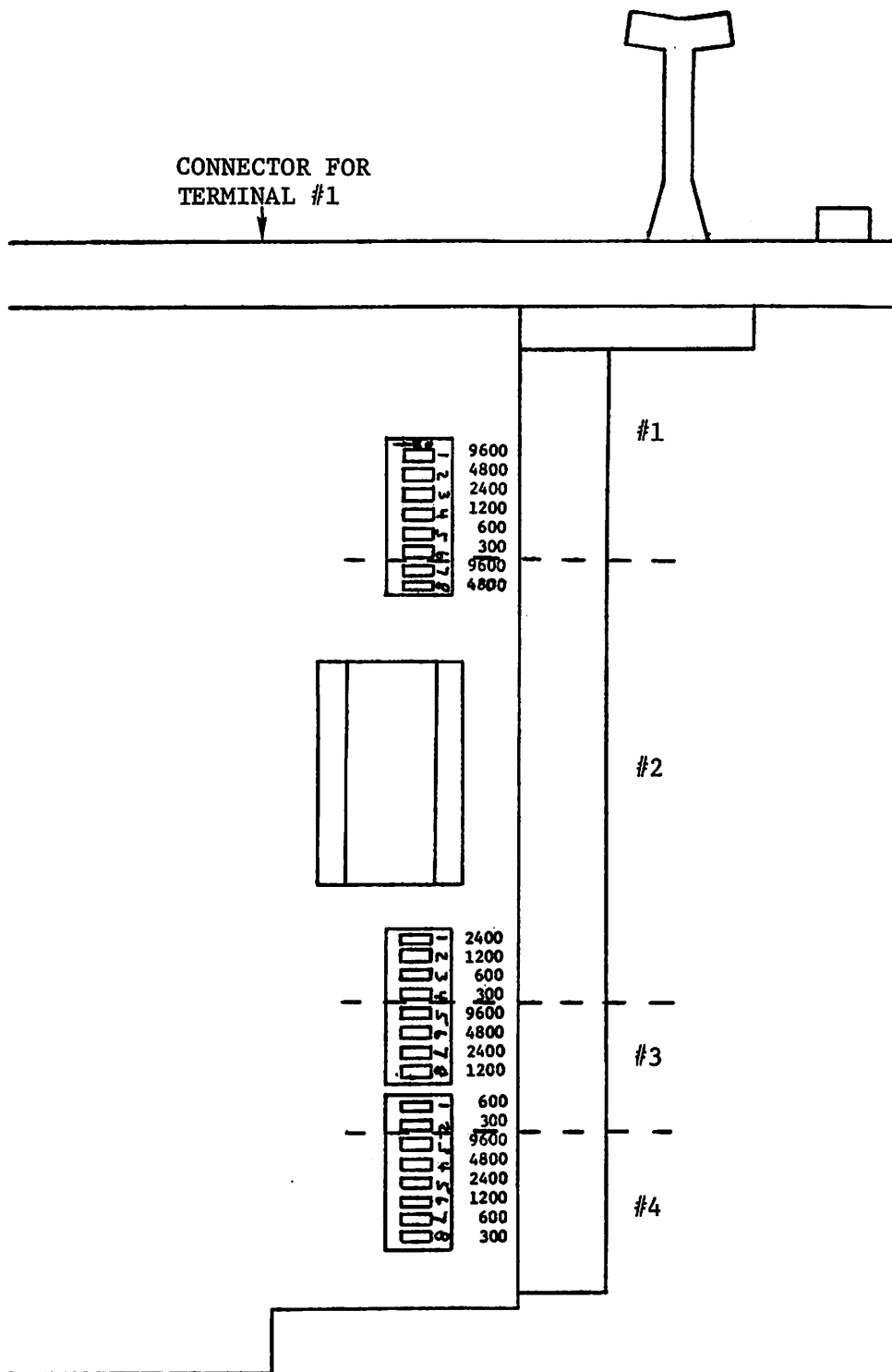

7290 BAUD RATE SWITCH IDENTIFICATION

2.3.3 2236MXC-2

The baud rate switches are set the same as in 2.3.2. In addition, the switch settings are etched on the 7294 controller.

2.4 SYSTEM CONFIGURATION

2.4.1 TYPICAL CONFIGURATION

A typical 2236 system is shown below.

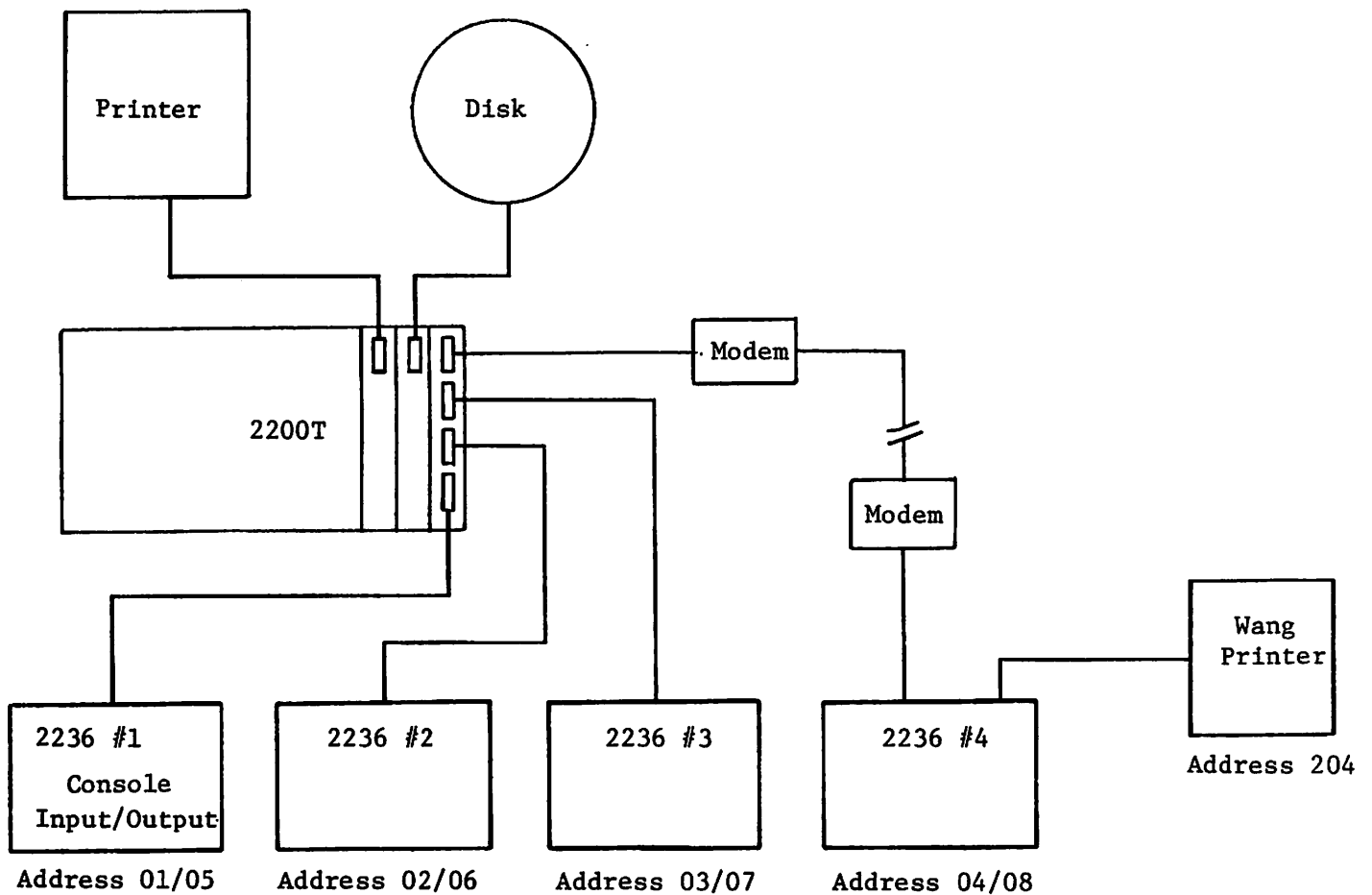

2.4.2 CONFIGURATION WITH 2226 AND 2236

Alternatively, a system could be configured as follows:

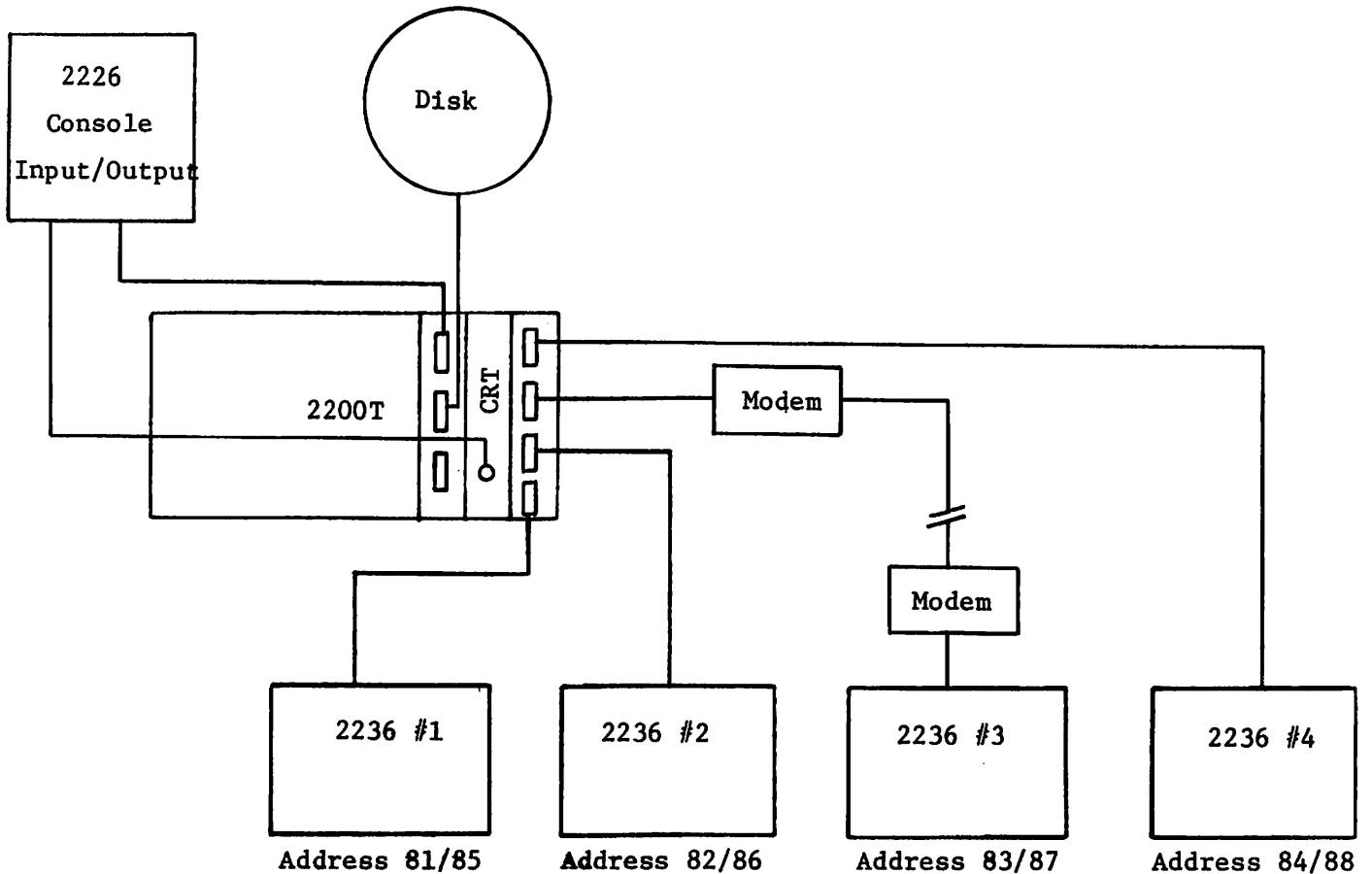

2.4.3 MODEM CONFIGURATIONS

2.5 CABLES

There are two types of cables available for the 2236. They are non-extendable direct connection type, and extendable modem types.

2.5.1 DIRECT CONNECTION CABLES

Each direct connection cable is marked to specify the correct end for connection to the 2236 terminal and 2236MXC. The end that MUST connect to the 2236 terminal is marked TERM on the connector.

2.5.2 MODEL CABLES

When using modems, connect the modem cable between the 2236MXC controller and the modem.

At the remote end, connect the CONTROLLER end of the connector to the modem, and the TERM end to the 2236 terminal.

2.5.3 CABLE SUMMARY

OPTIONAL CABLE STATISTICS

Type of Cable: Direct Connection (non-extendable)

<u>Length</u>	<u>Part Number</u>
25 feet (7.6m)	120-2236-25 (standard, see note)
50 feet (15.2m)	120-2236-50
100 feet (30.5m)	120-2236-1
200 feet (70.0m)	120-2236-2
300 feet (91.4m)	120-2236-3
400 feet (122m)	120-2236-4
500 feet (152m)	120-2236-5
600 feet (183m)	120-2236-6
700 feet (213m)	120-2236-7
800 feet (244m)	120-2236-8
900 feet (274m)	120-2236-9
1000 feet (305m)	120-2236-10

Type of Cable: Modem Connection

<u>Length</u>	<u>Part Number</u>
12 feet (3.7m)	220-0113 (Extendable)
25 feet (7.6m)	120-2227-25 (Extension Cable)
50 feet (15.2m)	120-2227-50 (Extension Cable)

SECTION 3
OPERATION

3.1 GENERAL

In a system using all 2236 terminals, console Input/Output is assigned to one 2236. By default, this is always #1, but any can be selected for console input/output by a SELECT statement to the address of the 2236 desired. Typically,

```
SELECT CO 006: SELECT CI002
```

would be used to select the second 2236.

The other 2236s in the system would be under PROGRAM CONTROL. They CANNOT function independently.

3.2 TAM

A software package is available for controlling the 2236s. It is known as Terminal Access Method subroutines (TAM). Refer to the TAM Operating Manual.

SECTION 4
THEORY OF OPERATION

TO BE PROVIDED AT A LATER DATE.

SECTION 5
DIAGNOSTICS

A 2236 system diagnostic has been added to the 2200 Peripheral Platter (701-2180B). The 2236 diagnostic has sixteen functional tests, each self-explanatory, with instructions displayed.

SECTION 6
CONVERSIONS AND UPGRADES

NO CONVERSIONS OR UPGRADES ARE AVAILABLE AT THIS TIME.

SECTION 7
MAINTENANCE

7.1 DISASSEMBLY

To disassemble the 2236 terminal:

- a) Remove the Special Function strip and the two keyboard faceplate screws beneath it.
- b) Remove one screw from each side of the 2236 cover.
- c) Lift the keyboard faceplate and cover away from the chassis.

7.2 PREVENTIVE MAINTENANCE

The 2236, like other Wang products, must be properly maintained for trouble-free operation. This requires periodic cleaning and visual and electrical checks.

7.2.1 CLEANING

Thorough cleaning should be performed periodically. Cleaning intervals are determined by the amount of use and environmental conditions. Under normal use and conditions, cleaning should be once every six months. In areas of excessive air contamination (smoke, dust, etc.) more frequent cleaning is required.

Clean the 2236 terminal as follows:

- a) Remove the keyboard face plate, front panel and cover.
- b) Remove the CRT electronics, voltage regulator and logic board from the 2236.
- c) Using a soft bristle brush, remove any accumulation of dust and dirt from the 2236 chassis and each of the pc boards, paying particular attention to the CRT chassis.

- d) Clean the finger connectors of each pc-board with an eraser.
- e) Use a mild detergent to clean the outside covers and the face of the CRT.
- f) Return all pc boards to the 2236.
- g) Reassemble the unit.

7.2.2 LUBRICATION

None required.

7.3. TROUBLESHOOTING

Determining where a problem exists in the 2236/2236MXC configuration can be accomplished by isolating the problem to the 2236 terminal or the MXC controller.

7.3.1 2236 TERMINAL

The terminal can be tested functionally by inserting a "loopback" connector on the rear panel. The loopback connector is an RS-232-C connector with pins 2 and 3 connected together with the loopback connector installed, keys depressed on the keyboard will be echoed back and displayed on the CRT.

This procedure will not completely check the 2236 terminal, but will verify that approximately 90% of the 2236 is functioning properly.

7.3.2 2236MXC CONTROLLER

Once each 2236 terminal has been functionally tested, connect one of the terminals to connector #1 on the 2236MXC controller.

Turn the CPU ON, and READY should be displayed on the 2236 terminal. If not, try a different 2236 terminal. If READY does not appear, check the address switch on the 2236MXC controller for all switches OFF.

Finally, replace the 2236MXC controller or the CPU logic modules.

7.4 ADJUSTMENTS

7.4.1 RECOMMENDED TEST EQUIPMENT/TOOL LIST

- a) Digital Voltmeter, with an accuracy of at least $\pm .1\%$ of full scale and 1 mv. resolution factor. Multimeter/VTVM accuracy and resolution factors are unacceptable for certain critical measurements.

Acceptable Type/Equivalent: FLUKE #8000A

- b) Multimeter, 20,000 Ω /v (min.); 2% or greater full scale accuracy; for less critical measurements.

Acceptable Type/Equivalent: TRIPLETT VOM #630NA

- c) Oscilloscope, with two x 1 probes and two x 10 probes.

Acceptable Type/Equivalent: TEKTRONIX #465

- d) Plastic Alignment Screwdriver for video display adjustments.

- e) Heavy Duty Screwdriver with heavily insulated handle and shaft, for discharge of video display anode voltage.

- f) Insulated Heavy-Gauge Ground Wire with insulated Alligator clips (for use with item (g), above).

- g) Small screwdriver with insulated shaft, used mostly for voltage adjustments.

7.4.2 2236 TERMINAL VOLTAGE ADJUSTMENTS

TABLE 7-1
2236 POWER SUPPLY ADJUSTMENTS (7067 REGULATOR)

LOCATION	VOLTAGE	LIMITS	ADJ	RIPPLE	
TP+5	+ 5VR	+4.95 vdc to +5.10 vdc	R4	20 mvp-p	7067, pin S/15
TP-5	- 5VR	-4.90 vdc to -5.10 vdc	R19	15 mvp-p	7067, pin 12
TP+12	+12VR	+11.80 vdc to +12.20 vdc	R10	50 mvp-p	7067, pin F/6
TP-12	-12VR	-11.80 vdc to -12.20 vdc	R16	50 mvp-p	7067, pin H/7

SECTION 8
BILL OF MATERIALS

ASSEMBLY PART NUMBER 177 2236 B
 ASSEMBLY DESCRIPTION 2236 TRANS TERMINAL(80X24) 6621-91 #=KIT TAG #=STATUS ITEM ##=FRACTIONA

PART NUMBER	DESCRIPTION	LEGEND	QUANTITY
210 7067 *	MODULE (PRELIM 928 & 2200F)	EC6845	1.00
210 7158 A *	7158-A MODULE 2236		1.00
209 7158	7158 W/UNLOADED SOCKETS (PRELIM)		1.00
220 1069	CABLE,CRT BD (7054)(F)B6482-86		1.00
210 7292 A	7292 MODULE (2236)		1.00
209 7292 *	7292 W/UNLOADED SOCKETS		1.00
270 0360	12" MONITOR ASSY(WITH PWR SUPPLY)		1.00
210 7256 *	7256 MODULE	EC6047	1.00
220 0160	BRIGHTNESS POT CABLE ASSY C6482-140	EC6389	1.00
270 3068	12" CRT HARNESS ASSY D6482-139	EC6389	1.00
270 0400	2236 WORK ST CHASSIS ASSY 6621-92		1.00
210 7293 *	7293 MODULE (2236)		1.00
220 3014	24 COND 14"FLAT CABLE C-6482-79	PATREL	1.00
220 1001	6 1/2" BLACK WIRE + LUG D6482-12		2.00
220 1042	P022 WIRE & LUG ASSY(2LCRT)D6482-12		1.00
220 1074	CABLE PS/MB(F CHASSIS)B6482-91		1.00
220 1076	POWER CORD ASSY(F CHAS)B6482-95		1.00
220 1077	P043 WIRE & LUG ASSY(F CHAS)B648296		1.00
220 1094	P048 WIRE & LUG ASSY B		1.00
220 1101	P054 WIRE&LUG ASSY(E CHAS)6482-12		2.00
271 1130	2236KEYBOARD&BEAR PLATE ASY 6621-90		1.00
279 1012	BASE ASSY(2200E/F)D6829-12		1.00
360 1011 SB	1 AMP FUSE SLO BLO 250 V	EC6934	1.00
360 1016 SB	1 1/2 AMP FUSE SLO BLO 250V	EC6934	1.00
400 1010	FAN,SKELETON(75CFM)ROTRON WR2H2		1.00
449 0101 9	FAN GUARD 4"(WHITE)D5300-1085		1.00
449 0111 9	A REZEL-12"CRT(WHITE)D6646-104		1.00
449 0186	COVER,MACHINING(CL VENTS)E6621-63	EC6934	1.00
452 2342	FINISH PLATE WLD & SILKSCR D6621-94		1.00
452 2517	700 PROGRAM CLAMPS B5900-39	(2	2.00
462 0265	SPACER,PC BOARD(E/F)C6815-13	EC6934	6.00
478 0061	700 PROGRAM CLAMP NUTS B5900-27	(2	2.00
615 0390	PROGRAM STRIP(SILK \$CR) C6857-2	EC6934	1.00
650 4133	8-32 X 3/8 FLANGE WHIZ-LOCK MS ZINC		4.00
650 4243 W	8-32 X 3/4 PAN HD PHL(OYSTER WHITE)		4.00
650 6121	10-32X3/8 TRUSS HD PHL MS SS		4.00
650 6241	SCR 10-32 3/4 PHIL FLAT H MS SS	EC6934	3.00
650 6243	10-32 X 3/4 TR. HD. PH. MS. SS.		4.00
650 6360 W	10-32X1 1/8 TRUSS HD PHL SS(WHITE)	EC6934	2.00
651 0021 W	SCR,#8X1/2 SELF TAP TRUSS HD(WHITE)		6.00
652 0029	8-32 LOCK-NUT KEPS 511-0818Q0-50		4.00

ASSEMBLY PART NUMBER 177 2236 B
 ASSEMBLY DESCRIPTION 2236 TRANS TERMINAL(80X24) 6621-91 #KIT TAG #STATUS ITEM ##=FRACTION/

LEGEND

PART NUMBER	DESCRIPTION	QUANTITY
654 1274	CABLE CLAMP ADH.BACK DKLSP 021-0375 EC6934	1.00
655 0009	PLUG BUTTON(BLACK)SS51338 P5001	2.00
655 0012	VENT.AIR D6915-17	3.00
655 0018 9	PLUG.BUTTON (OYSTER WHITE) EC6934	1.00
655 0157	612/712 KNOB ALCO KN700BA EC6934	2.00

SECTION 9
NEW SCHEMATICS

BOARD PART #	DESCRIPTION
210-7158	I/O 80 x 24 CRT, PRINTER
210-7290	INTERACTIVE TERMINAL CONTROLLER
210-7291	8080 INTERACTIVE TERMINAL MEMORY
210-7292	W.S. ELECTRONICS
210-7293	INTERACTIVE TERMINAL MOTHERBOARD
210-7294	8080 MXC GRAND DAUGHTER BOARD

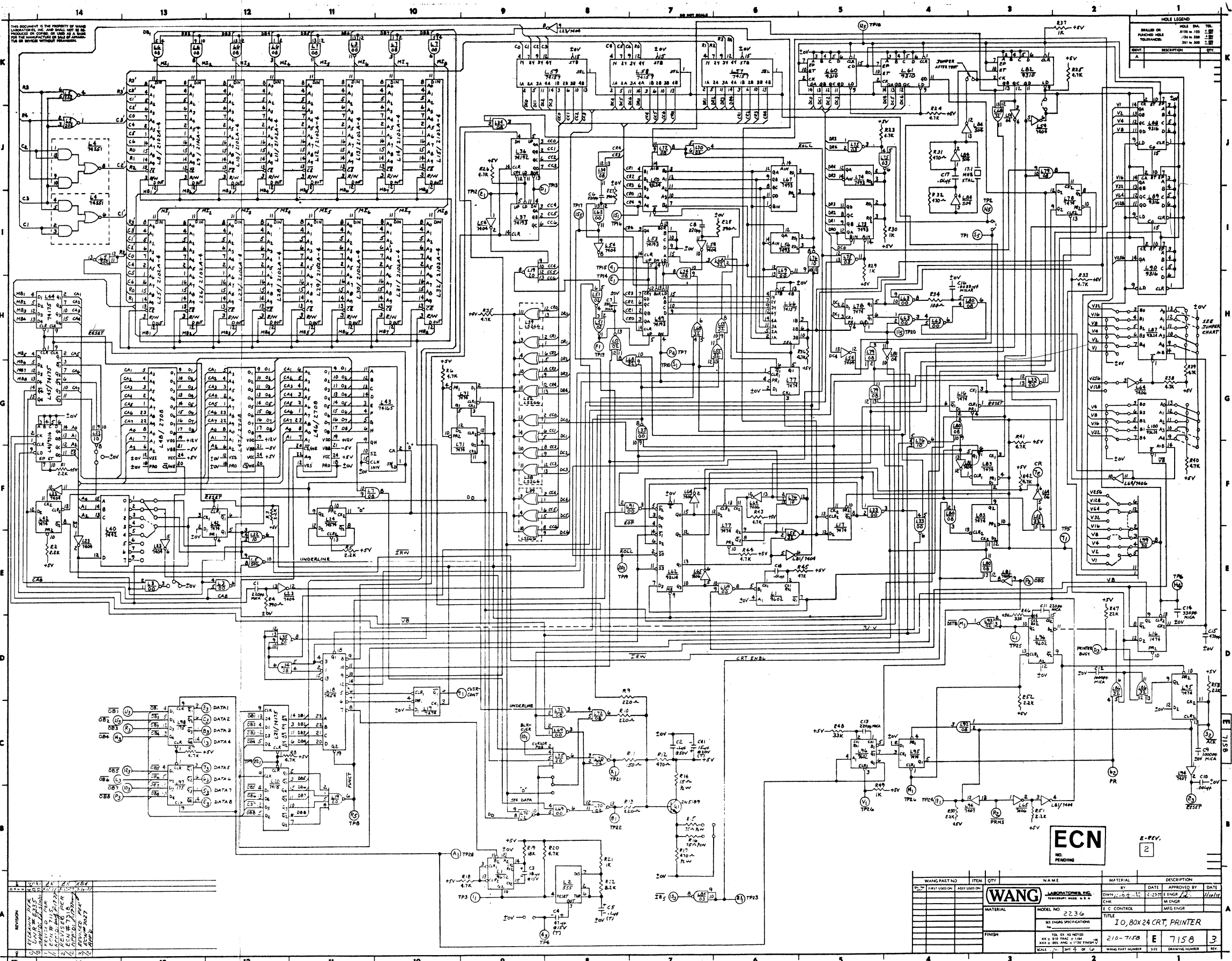

THIS DOCUMENT IS THE PROPERTY OF WANG LABORATORIES, INC. AND SHALL NOT BE REPRODUCED OR TRANSMITTED IN ANY FORM OR BY ANY MEANS, ELECTRONIC OR MECHANICAL, INCLUDING PHOTOCOPYING, RECORDING, OR BY ANY INFORMATION STORAGE AND RETRIEVAL SYSTEM, WITHOUT PERMISSION.

HOLE LEGEND	
DRILLED OR PUNCHING HOLES	SIZE DIA. TOL.
DRILLED HOLES	.015 ± .002
PLATE HOLES	.125 ± .002
TELETYPE HOLES	.375 ± .002
IDENT.	DESCRIPTION
A	

REV.	DESCRIPTION
1	REVISION
2	REVISION
3	REVISION
4	REVISION
5	REVISION
6	REVISION
7	REVISION
8	REVISION
9	REVISION
10	REVISION
11	REVISION
12	REVISION
13	REVISION
14	REVISION

ECN NO. PENDING E-REV. 2																									
<table border="1"> <thead> <tr> <th>WANG PART NO.</th> <th>ITEM</th> <th>QTY</th> <th>NAME</th> <th>MATERIAL</th> <th>DESCRIPTION</th> </tr> </thead> <tbody> <tr> <td>7150</td> <td>1</td> <td>1</td> <td>7150</td> <td>7150</td> <td>7150</td> </tr> </tbody> </table>	WANG PART NO.	ITEM	QTY	NAME	MATERIAL	DESCRIPTION	7150	1	1	7150	7150	7150	<table border="1"> <thead> <tr> <th>BY</th> <th>DATE</th> <th>APPROVED BY</th> <th>DATE</th> </tr> </thead> <tbody> <tr> <td>CHK</td> <td>11/23/78</td> <td>ENGR</td> <td>11/23/78</td> </tr> <tr> <td>TEC CONTROL</td> <td></td> <td>MEG ENGR</td> <td></td> </tr> </tbody> </table>	BY	DATE	APPROVED BY	DATE	CHK	11/23/78	ENGR	11/23/78	TEC CONTROL		MEG ENGR	
WANG PART NO.	ITEM	QTY	NAME	MATERIAL	DESCRIPTION																				
7150	1	1	7150	7150	7150																				
BY	DATE	APPROVED BY	DATE																						
CHK	11/23/78	ENGR	11/23/78																						
TEC CONTROL		MEG ENGR																							
<table border="1"> <thead> <tr> <th>MODEL NO.</th> <th>TITLE</th> </tr> </thead> <tbody> <tr> <td>223 G</td> <td>IO, 80X24 CRT, PRINTER</td> </tr> </tbody> </table>		MODEL NO.	TITLE	223 G	IO, 80X24 CRT, PRINTER																				
MODEL NO.	TITLE																								
223 G	IO, 80X24 CRT, PRINTER																								
<table border="1"> <thead> <tr> <th>FINISH</th> <th>SCALE</th> <th>DATE</th> <th>NO.</th> </tr> </thead> <tbody> <tr> <td>210-7150</td> <td>E</td> <td>7150</td> <td>3</td> </tr> </tbody> </table>		FINISH	SCALE	DATE	NO.	210-7150	E	7150	3																
FINISH	SCALE	DATE	NO.																						
210-7150	E	7150	3																						

THIS DOCUMENT IS THE PROPERTY OF WANG LABORATORIES, INC. AND SHALL NOT BE REPRODUCED OR COPIED IN ANY MANNER FOR THE MANUFACTURE OR SALE OF ANYTHING OR SERVICE WITHOUT PERMISSION.

LOCATION	WVL. PT. NO.	VEC	QND
L1, 76	376-0104	16	8
L2	376-0126	8	1
L3, 33, 62, 69, 71	376-0002	14	7
L4	376-0105	14	7
L5	376-0179	14	7
L6, 7, 74, 75, 84, 92	376-0001	14	7
L8-15, 25-32	377-0069	10	9
L16, 18, 46, 71, 77, 78, 83, 95	376-0006	14	7
L18	376-0090	24	12
L19, 35	376-0005	14	7
L20, 41, 44, 45, 93, 98	376-0019	16	8
L22, 76	376-0003	14	7
L23, 56, 81	376-0010	14	7
L24	376-0302	14	7
L26	376-0190	16	8
L28, 39, 52	376-0118	14	7
L40	376-0008	16	8
L41, 88, 89, 90	376-0096	16	8
L43	376-0105	16	8
L44, 47, 48	377-0217	24	12
L37, 49, 53	376-0053	16	8
L50, 87, 100	376-0120	16	8
L51, 70, 93	376-0016	14	7
L55, 68, 86	376-0093	14	7
L56, 67, 73, 74	376-0011	5	10
L57, 58, 59, 66	376-0082	16	8
L60, 61, 82	376-0191	16	8
L62	376-0162	16	8
L64, 65	376-0055	16	7
L75, 85	376-0028	16	7
L84	376-0197	14	7
L94	376-0056	14	7
L99	376-0031	14	7
L8-15, 25-32	376-9002		
L8, 46-48	376-9003		

LOCATION	TYPE	QTY
L3	7400	1
L22	7410	1
L23	7409	1
L24	7407	1
L27	7402	1
L44	7406	1
L45	7406	4
L72	7408	1
L78	7408	1
L81	7404	1
L85	7403	3
L86	7432	2
L91	7400	3
L92	7408	3
L93	7402	3
L94	7407	4
L75	7403	1
L84	74104	3

COMPONENT	WVL. PT. NO.
R1, 2, 3, 4, 50-53	330-3032
R4, 17, 28	330-2049
R6, 7, 8, 18, 23, 24, 25, 26, 27, 28, 29, 30, 31, 32, 33, 34, 35, 36, 37, 40-44	330-3047
R9, 10, 13	330-2022
R11	330-2011
R13, 31, 32	330-2041
R14	331-1010
R15, 16	331-1070
R19	330-4010
R21, 30, 37, 39, 29	330-3010
R22	330-3008
R24	330-1010
R45	330-4001
R46, 48	330-4032
R17	331-2041
R1	375-1021
R1 TRANS-PAD	375-900
X7AL	321-0010
C1, 11, 13	300-5000
C9, 12	300-5006
C3	300-4010
C4	300-4010
C5	300-4002
C6, 8	300-1230
C7, 14	300-5017
C10	300-1946
C15	300-1930
C16	300-2033
C17, 18	300-1900
C19, 20, 38-41	300-4032
C21-27	300-1900
C2	300-1930

JUMPER CHART		
7158-1	7158	
COMMON	20V	60V
0	0	0

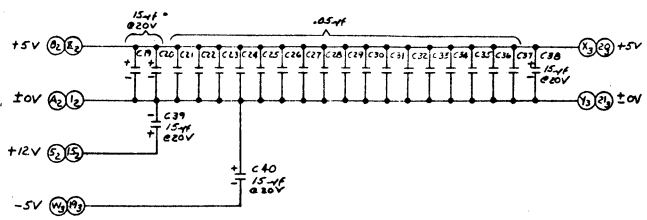
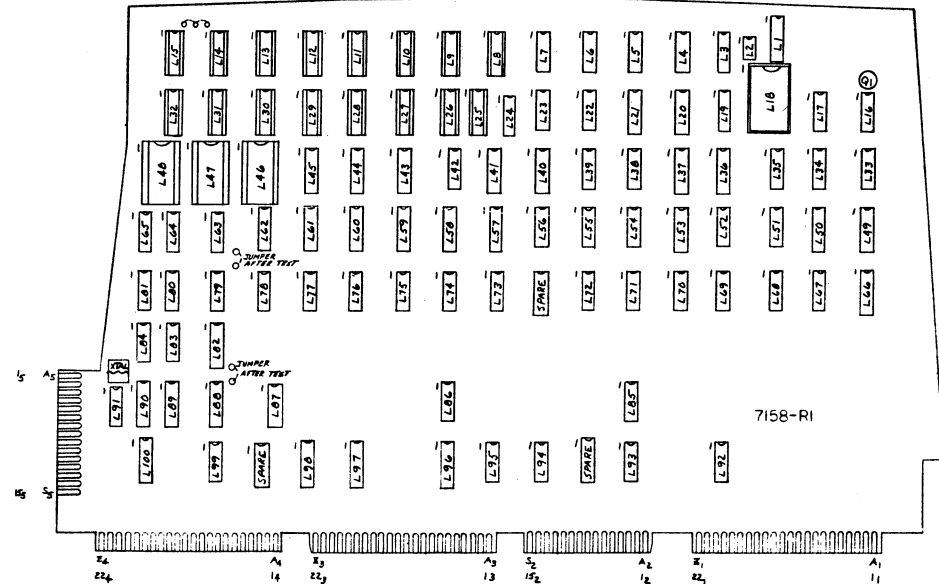

REV.	DESCRIPTION
A	

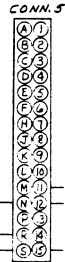
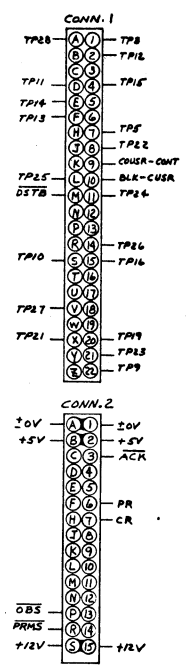

ECN
NO. PENDING

WANG PART NO.	ITEM	QTY	NAME	MATERIAL	DESCRIPTION
7158-1	7158		LABORATORIES, INC.		
			MODEL NO.	223C	
			TITLE	IO, 80X24 CRT, PRINTER	
			DATE	210-7158	
			SCALE	1:1	

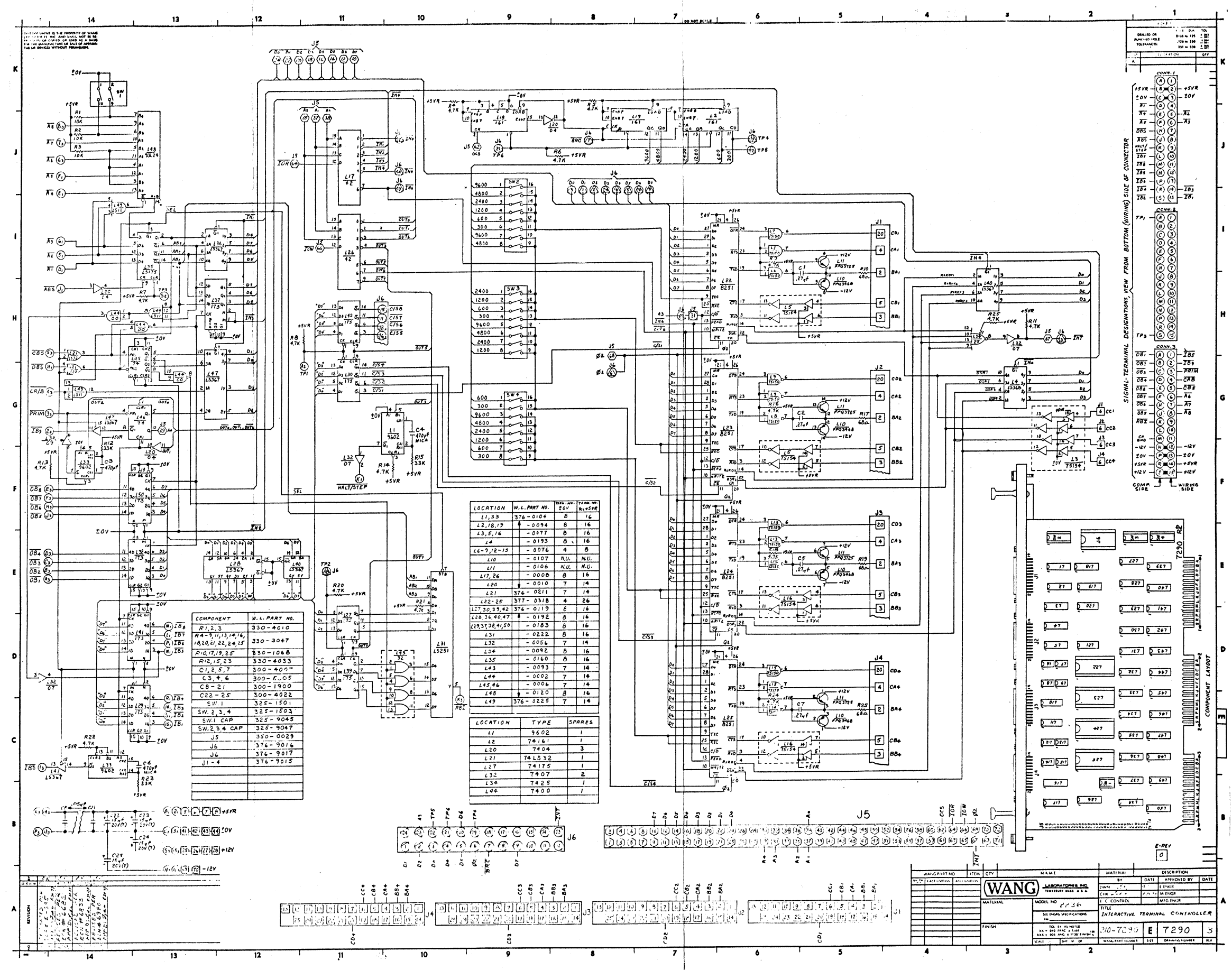

1. ALL WIRING IS TO BE DONE IN ACCORDANCE WITH THE WIRING STANDARDS OF THE MILITARY STANDARD 883C. 2. ALL WIRING IS TO BE DONE IN ACCORDANCE WITH THE WIRING STANDARDS OF THE MILITARY STANDARD 883C. 3. ALL WIRING IS TO BE DONE IN ACCORDANCE WITH THE WIRING STANDARDS OF THE MILITARY STANDARD 883C.

COMPONENT	W.L. PART NO.	QTY	TERMINAL
R1, 2, 3	330-4010	3	16
R4-9, 11, 13, 14, 16, 18, 20, 21, 22, 24, 25	330-3047	16	16
R10, 17, 19, 23	330-1068	4	16
R12, 15, 23	330-4033	3	16
C1, 2, 5, 7	300-4009	7	16
C3, 4, 6	300-F-05	6	16
C8 - 21	300-1900	14	16
C22 - 25	300-4022	4	16
SW1 - 1	325-1501	1	16
SW2, 3, 4	325-1503	3	16
SW1 CAP	325-9048	1	16
SW2, 3, 4 CAP	325-9047	3	16
J5	350-0029	1	16
J6	374-9016	1	16
J1 - 4	374-9015	4	16

LOCATION	W.L. PART NO.	QTY	TERMINAL
L1, 3, 3	376-0104	3	16
L2, 18, 19	-0094	3	16
L3, 5, 16	-0077	3	16
L4	-0193	1	16
L6-9, 12-15	-0076	4	16
L10	-0107	1	16
L11	-0106	1	16
L17, 26	-0000	2	16
L20	-0010	1	16
L21	376-0211	1	16
L22-25	377-0318	4	16
L27, 30, 33, 42	376-0119	4	16
L28, 34, 40, 47	-0192	4	16
L29, 37, 38, 41, 50	-0183	4	16
L31	-0222	1	16
L32	-0054	1	16
L34	-0092	1	16
L35	-0160	1	16
L43	-0093	1	16
L44	-0002	1	16
L45, 46	-0006	2	16
L48	-0120	1	16
L49	376-0225	1	16

LOCATION	TYPE	SPARES
L1	9602	1
L2	74161	1
L20	7404	3
L21	74LS32	1
L27	74175	1
L35	7407	2
L34	7425	1
L44	7400	1

DATE	BY	DESCRIPTION
10/15/70	J. J. [unclear]	REVISED
10/15/70	J. J. [unclear]	REVISED
10/15/70	J. J. [unclear]	REVISED

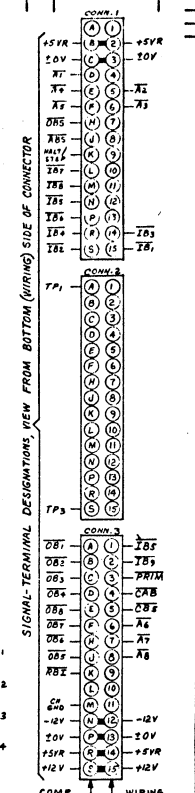

WANG PART NO.	ITEM	QTY	NAME	MATERIAL	DESCRIPTION
376-0104	L1	3	INDUCTOR	376-0104	INDUCTOR
376-0211	L21	1	INDUCTOR	376-0211	INDUCTOR
376-0318	L22-25	4	INDUCTOR	376-0318	INDUCTOR
376-0119	L27, 30, 33, 42	4	INDUCTOR	376-0119	INDUCTOR
-0192	L28, 34, 40, 47	4	INDUCTOR	-0192	INDUCTOR
-0183	L29, 37, 38, 41, 50	4	INDUCTOR	-0183	INDUCTOR
-0222	L31	1	INDUCTOR	-0222	INDUCTOR
-0054	L32	1	INDUCTOR	-0054	INDUCTOR
-0092	L34	1	INDUCTOR	-0092	INDUCTOR
-0160	L35	1	INDUCTOR	-0160	INDUCTOR
-0093	L43	1	INDUCTOR	-0093	INDUCTOR
-0002	L44	1	INDUCTOR	-0002	INDUCTOR
-0006	L45, 46	2	INDUCTOR	-0006	INDUCTOR
-0120	L48	1	INDUCTOR	-0120	INDUCTOR
376-0225	L49	1	INDUCTOR	376-0225	INDUCTOR

DATE	BY	DATE	APPROVED BY
10/15/70	J. J. [unclear]	10/15/70	[unclear]
10/15/70	J. J. [unclear]	10/15/70	[unclear]
10/15/70	J. J. [unclear]	10/15/70	[unclear]

WANG MODEL NO. 7290
 TITLE: INTERACTIVE TERMINAL CONTROLLER
 DATE: 10/15/70
 DRAWING NUMBER: E 7290 3

THIS DOCUMENT IS THE PROPERTY OF WANG LABORATORIES, INC. AND SHALL NOT BE REPRODUCED OR COPIED IN ANY MANNER WITHOUT THE WRITTEN PERMISSION OF WANG LABORATORIES, INC.

HOLE LEGEND		
DRILL DIA.	HOLE DIA.	TK
.0315	.0315	1
.0630	.0630	2
.1260	.1260	3
.1890	.1890	4
.2520	.2520	5
DESC. <td>REV. </td>		REV.
A		

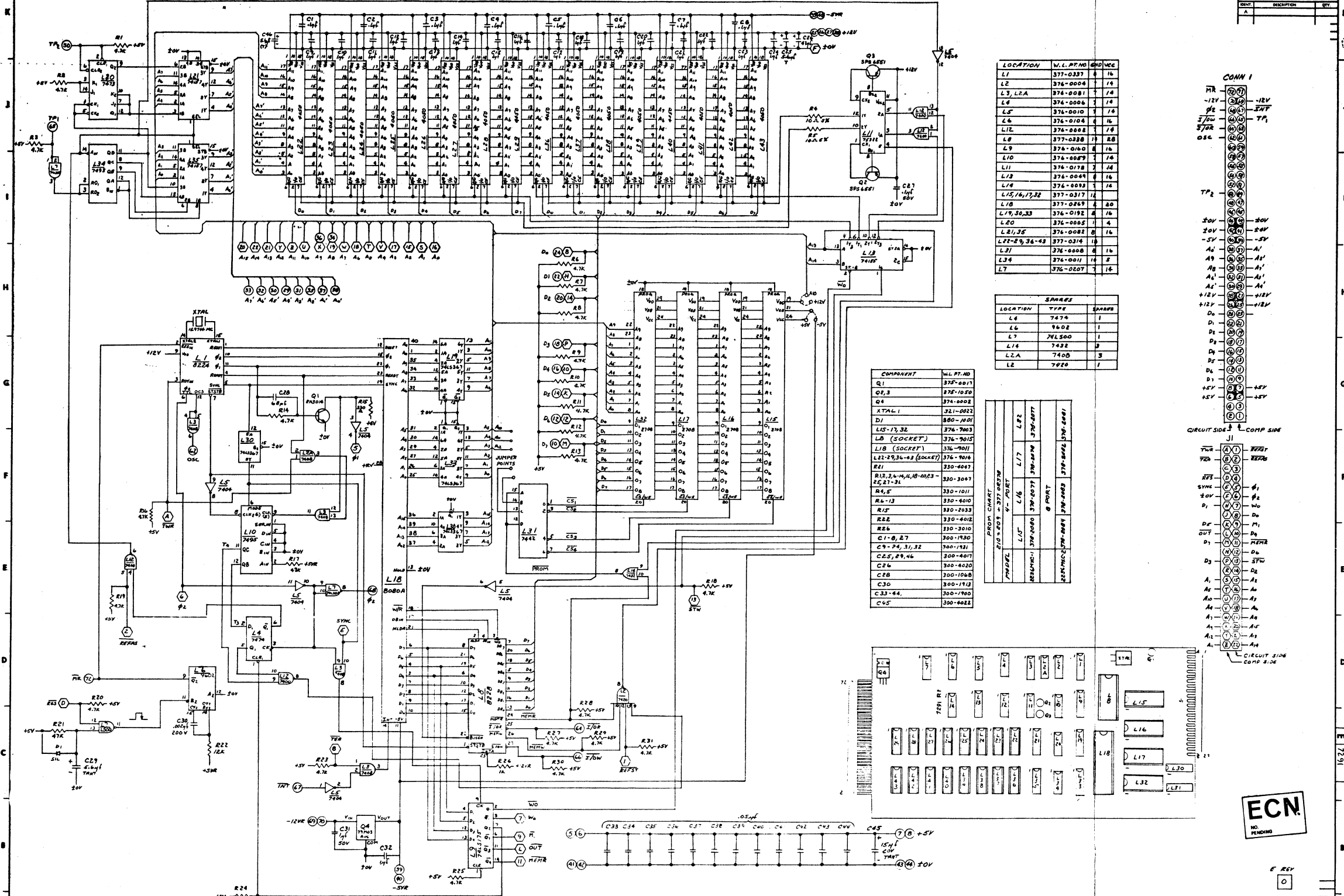

LOCATION	W.L. PT. NO.	QTY	REV.
L1	377-0337	1	16
L2	376-0006	1	16
L3, L2A	376-0081	1	16
L4	376-0004	1	16
L5	376-0010	1	16
L6	376-0106	1	16
L12	376-0002	1	16
L8	377-0328	1	16
L9	376-0160	1	16
L10	376-0089	1	16
L11	376-0178	1	16
L13	376-0049	1	16
L14	376-0093	1	16
L15, 16, 17, 22	377-0317	1	16
L18	377-0267	1	16
L19, 20, 33	376-0192	1	16
L20	376-0082	1	16
L21, 35	376-0082	1	16
L22-29, 36-43	377-0319	1	16
L31	376-0008	1	16
L34	376-0011	1	16
L7	376-0207	1	16

LOCATION	TYPE	QTY
L6	7474	1
L6	7402	1
L7	741500	1
L14	7432	3
L2A	7405	3
L2	7422	1

COMPONENT	W.L. PT. NO.
Q1	375-0017
Q2, 3	375-1050
Q4	374-0022
Q5	374-0022
XTAL 1	321-0022
D1	880-1001
L15-17, 32	376-7003
L3 (SOCKET)	376-7015
L18 (SOCKET)	376-7011
L22-29, 36-43 (SOCKET)	376-7004
R21	330-4047
R12, 34, 44, 48-0023	330-3041
R2, 21-31	330-1011
R4, 5	330-1011
R6-13	330-4020
R15	330-2033
R22	330-4012
R25	330-3010
C1-8, 27	300-1930
C9-24, 31, 32	300-1931
C25, 29, 46	300-4017
C26	300-4020
C28	300-1068
C30	300-1913
C33-44	300-1900
C45	300-4022

FROM CHART	W.L. PT. NO.	QTY
7474	376-0082	1
741500	376-0082	1
7432	376-0082	3
7405	376-0082	3
7422	376-0082	1

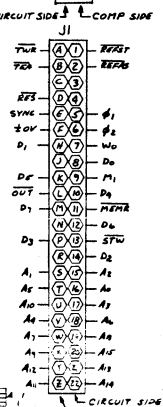
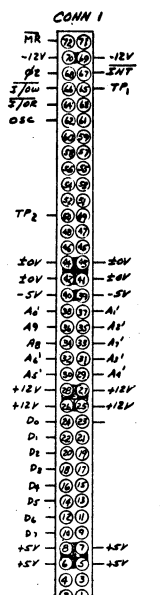

ECN
NO. PENDING

REV.	DATE	DESCRIPTION
0	11/17/77	ORIGINAL REV.
1	11/17/77	REVISED FOR
2	11/17/77	REVISED FOR
3	11/17/77	REVISED FOR
4	11/17/77	REVISED FOR
5	11/17/77	REVISED FOR

ECN

WANG PART NO.	ITEM	QTY	NAME	MATERIAL	DESCRIPTION
210-7291	1	1	WANG		
210-7291	2	1	WANG		
210-7291	3	1	WANG		
210-7291	4	1	WANG		
210-7291	5	1	WANG		
210-7291	6	1	WANG		
210-7291	7	1	WANG		
210-7291	8	1	WANG		
210-7291	9	1	WANG		
210-7291	10	1	WANG		
210-7291	11	1	WANG		
210-7291	12	1	WANG		
210-7291	13	1	WANG		
210-7291	14	1	WANG		

DATE	BY	DATE	APPROVED BY	DATE
11/17/77	...	11/17/77
11/17/77	...	11/17/77

TITLE	SCALE	WANG PART NUMBER	REV.
TITLE: 210-7291 INTERACTIVE TERMINAL PORT LA WATER BOARD	SCALE: 1:1	210-7291	REV. 7291 2

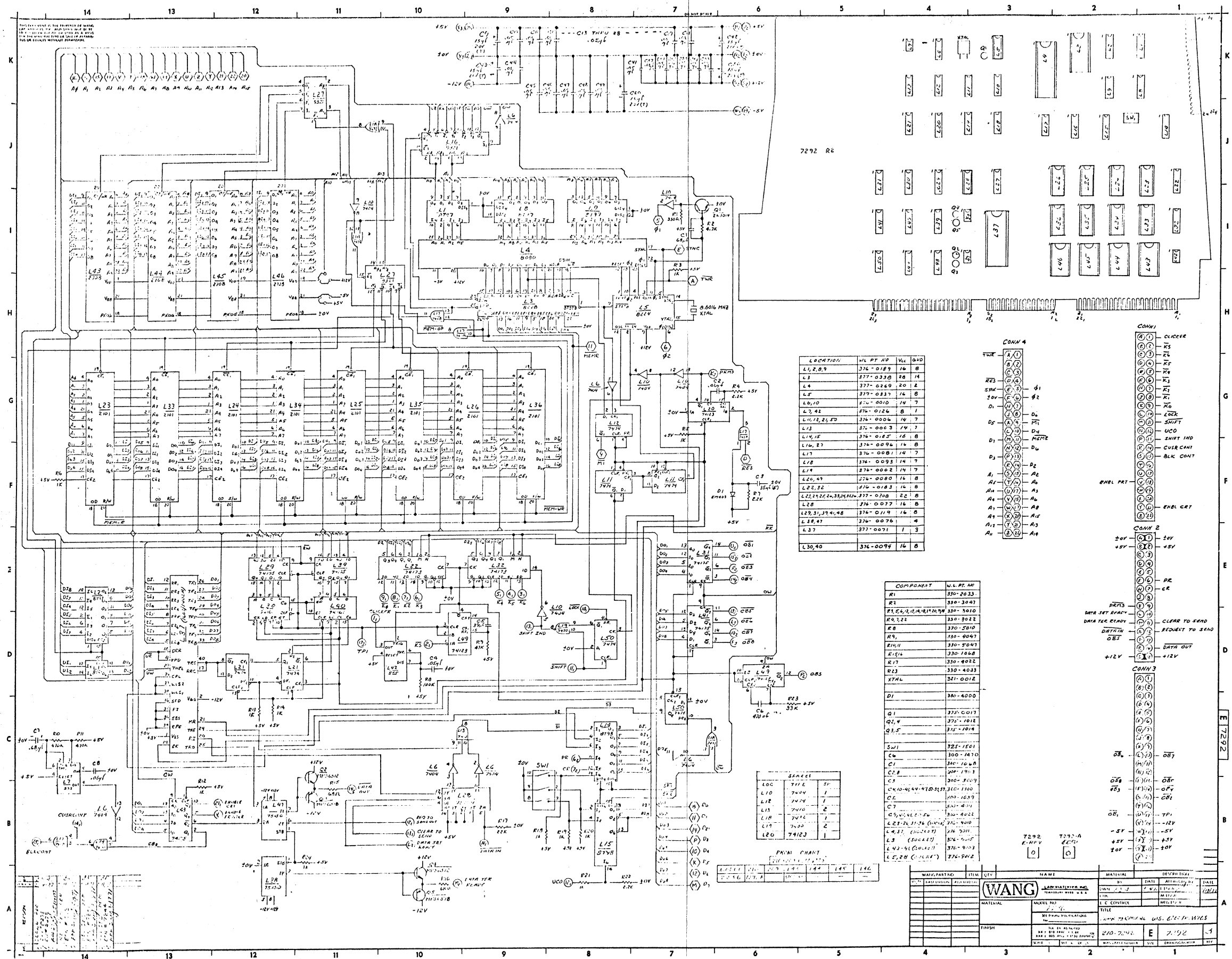

LOCATION	W.L.P.T. NO.	VAL.	QTY.
L1, 2, 8, 9	376-0189	16 8	
L3	377-0330	20 14	
L4	377-0269	20 14	
L5	377-0337	16 8	
L6, 10	376-0010	16 7	
L7, 42	376-0126	8 1	
L11, 12, 21, 22	376-0004	16 7	
L13	376-0063	16 8	
L14, 15	376-0185	16 8	
L16, 23	376-0094	16 8	
L17	376-0081	16 7	
L18	376-0093	16 7	
L19	376-0002	16 7	
L26, 49	376-0080	16 8	
L28, 32	376-0183	16 8	
L25, 24, 25, 26, 33, 34, 35, 37, 38, 39, 40, 41, 42, 43, 44, 45, 46, 47, 48	376-0308	22 8	
L28	376-0077	16 8	
L29, 31, 39, 41, 48	376-0119	16 8	
L38, 47	376-0076	8	
L37	377-0071	1 3	
L30, 40	376-0094	16 8	

COMPONENT	W.L.P.T. NO.
R1	330-2033
R2	330-3041
R3, 5, 6, 7, 8, 9, 10, 11, 12, 13, 14, 15, 16, 17, 18, 19, 20, 21, 22, 23, 24, 25, 26, 27, 28, 29, 30, 31, 32, 33, 34, 35, 36, 37, 38, 39, 40, 41, 42, 43, 44, 45, 46, 47, 48, 49, 50, 51, 52, 53, 54, 55, 56, 57, 58, 59, 60, 61, 62, 63, 64, 65, 66, 67, 68, 69, 70, 71, 72, 73, 74, 75, 76, 77, 78, 79, 80, 81, 82, 83, 84, 85, 86, 87, 88, 89, 90, 91, 92, 93, 94, 95, 96, 97, 98, 99, 100	330-3022
R4, 22	330-3022
R6, 22	330-3010
R9	330-4047
R10, 11	330-5047
R15, 16	330-1068
R17	330-4022
R23	330-4033
XTAL	321-0012
D1	330-4000
Q1	330-0017
Q1, 4	330-7012
Q3, 5	330-7014
S, 11	325-1001
C6	300-10410
C7	300-1068
C8	300-1033
C9	300-1001
C10, 11, 12, 13, 14, 15, 16, 17, 18, 19, 20, 21, 22, 23, 24, 25, 26, 27, 28, 29, 30, 31, 32, 33, 34, 35, 36, 37, 38, 39, 40, 41, 42, 43, 44, 45, 46, 47, 48, 49, 50, 51, 52, 53, 54, 55, 56, 57, 58, 59, 60, 61, 62, 63, 64, 65, 66, 67, 68, 69, 70, 71, 72, 73, 74, 75, 76, 77, 78, 79, 80, 81, 82, 83, 84, 85, 86, 87, 88, 89, 90, 91, 92, 93, 94, 95, 96, 97, 98, 99, 100	300-1100
C1	300-1089
C2	300-1001
C3, 4, 5, 6, 7, 8, 9, 10, 11, 12, 13, 14, 15, 16, 17, 18, 19, 20, 21, 22, 23, 24, 25, 26, 27, 28, 29, 30, 31, 32, 33, 34, 35, 36, 37, 38, 39, 40, 41, 42, 43, 44, 45, 46, 47, 48, 49, 50, 51, 52, 53, 54, 55, 56, 57, 58, 59, 60, 61, 62, 63, 64, 65, 66, 67, 68, 69, 70, 71, 72, 73, 74, 75, 76, 77, 78, 79, 80, 81, 82, 83, 84, 85, 86, 87, 88, 89, 90, 91, 92, 93, 94, 95, 96, 97, 98, 99, 100	300-4022
C12, 13, 14, 15, 16, 17, 18, 19, 20, 21, 22, 23, 24, 25, 26, 27, 28, 29, 30, 31, 32, 33, 34, 35, 36, 37, 38, 39, 40, 41, 42, 43, 44, 45, 46, 47, 48, 49, 50, 51, 52, 53, 54, 55, 56, 57, 58, 59, 60, 61, 62, 63, 64, 65, 66, 67, 68, 69, 70, 71, 72, 73, 74, 75, 76, 77, 78, 79, 80, 81, 82, 83, 84, 85, 86, 87, 88, 89, 90, 91, 92, 93, 94, 95, 96, 97, 98, 99, 100	300-7010
L3, 31 (S0641)	376-7011
L3, 41 (S0641)	376-7012
L3, 28 (S0641)	376-7013

LOC.	SEARCH	QTY.
L10	7412	1
L12	7412	1
L13	7412	2
L14	7412	1
L15	7412	1
L16	7412	1
L17	7412	1
L18	7412	1
L19	7412	1
L20	7412	1

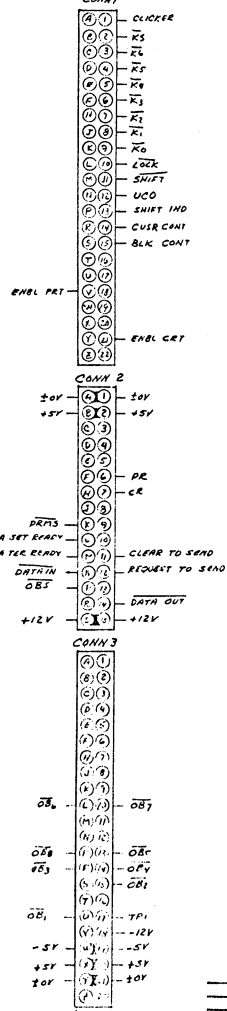
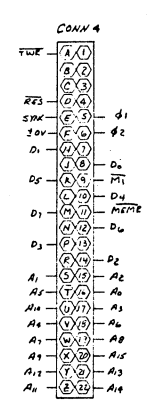

WANG PART NO.	ITEM	QTY.	NAME	MATERIAL	DESCRIPTION
7292	1	1	7292 RE	7292 RE	7292 RE

REVISIONS TO THE PROJECT OF NAME
DATE: 11/11/62 BY: [Signature]
REASON: [Text]

THE INFORMATION CONTAINED IN THIS DRAWING IS THE PROPERTY OF WANG LABORATORIES, INC. AND IS CONFIDENTIAL AND PROPRIETARY TO WANG LABORATORIES, INC. IT MAY NOT BE COPIED, REPRODUCED OR USED IN WHOLE OR IN PART FOR ANY REASON.

MILLIMETERS IN PARENTHESIS. TOLERANCES TO BE EQUIVALENT TO INCH DIMENSIONS.

HOLE LEGEND & TOLERANCES		
HOLE DIA	TOLERANCE	
Ø13 - 175	+0.03 - 0.01	
178 - 258	+0.04 - 0.01	
261 - 309	+0.05 - 0.01	
SYM	DESCRIPTION	QTY
A		

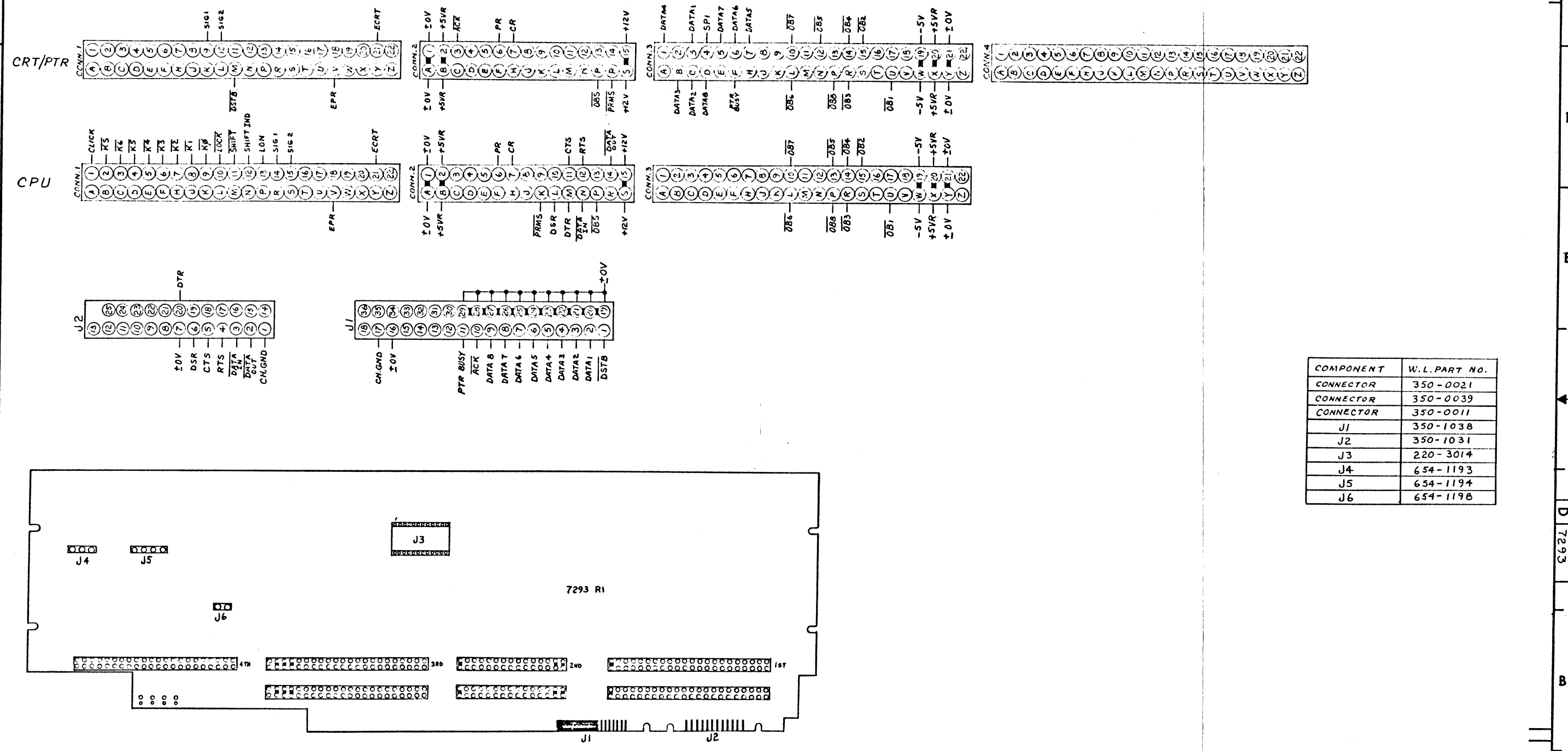

COMPONENT	W.L. PART NO.
CONNECTOR	350-0021
CONNECTOR	350-0039
CONNECTOR	350-0011
J1	350-1038
J2	350-1031
J3	220-3014
J4	654-1193
J5	654-1194
J6	654-1198

REVISION	NO	DATE	BY	DESCRIPTION				
	1	11-22-77	DK	ORIGINATED PER DWR # 22191				
	2	12-22-77	DK	APPROVED PER ECR # 6590				
				REVISED PER APP'D: [Signature]				
QTY	ITEM	WANG PART NO	DRAWING NO.	DESCRIPTION	BY	DATE	APPROVED BY	DATE
	NEXT ASSY	WANG		LABORATORIES, INC. TEMPERBURY, MASS. U.S.A.	DWN	11-27-77	E ENGR	11/28/77
				MODEL NO 2236	CHR		M ENGR	
				SEE ENGR SPECIFICATIONS			MFG ENGR	
				TOL ER AS NOTED	TITLE INTERACTIVE TERMINAL W.S. MOTHER BOARD			
				FINISH	210-7293	D	7293	0
				SCALE	WANG PART NUMBER	SIZE	DRAWING NUMBER	REV

THIS DOCUMENT IS THE PROPERTY OF WANG LABORATORIES, INC. AND SHALL NOT BE REPRODUCED OR COPIED OR USED AS A BASIS FOR THE MANUFACTURE OR SALE OF EQUIPMENT OR SERVICE WITHOUT PERMISSION.

HOLE LEGEND		
DRILLED OR PLACED HOLES	HOLE DIA.	TOL.
PLACEMENT	0.125 ± 0.005	± 0.005
PLACEMENT	0.1875 ± 0.005	± 0.005
PLACEMENT	0.250 ± 0.005	± 0.005
PLACEMENT	0.3125 ± 0.005	± 0.005

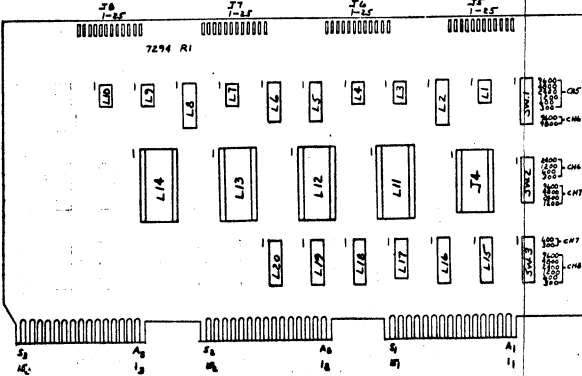
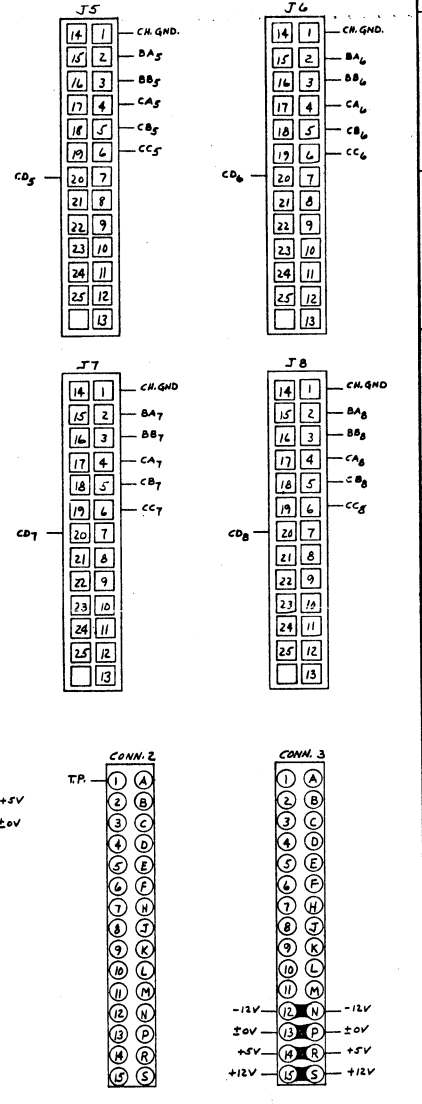
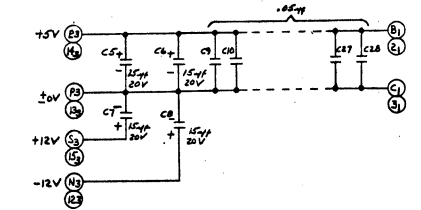
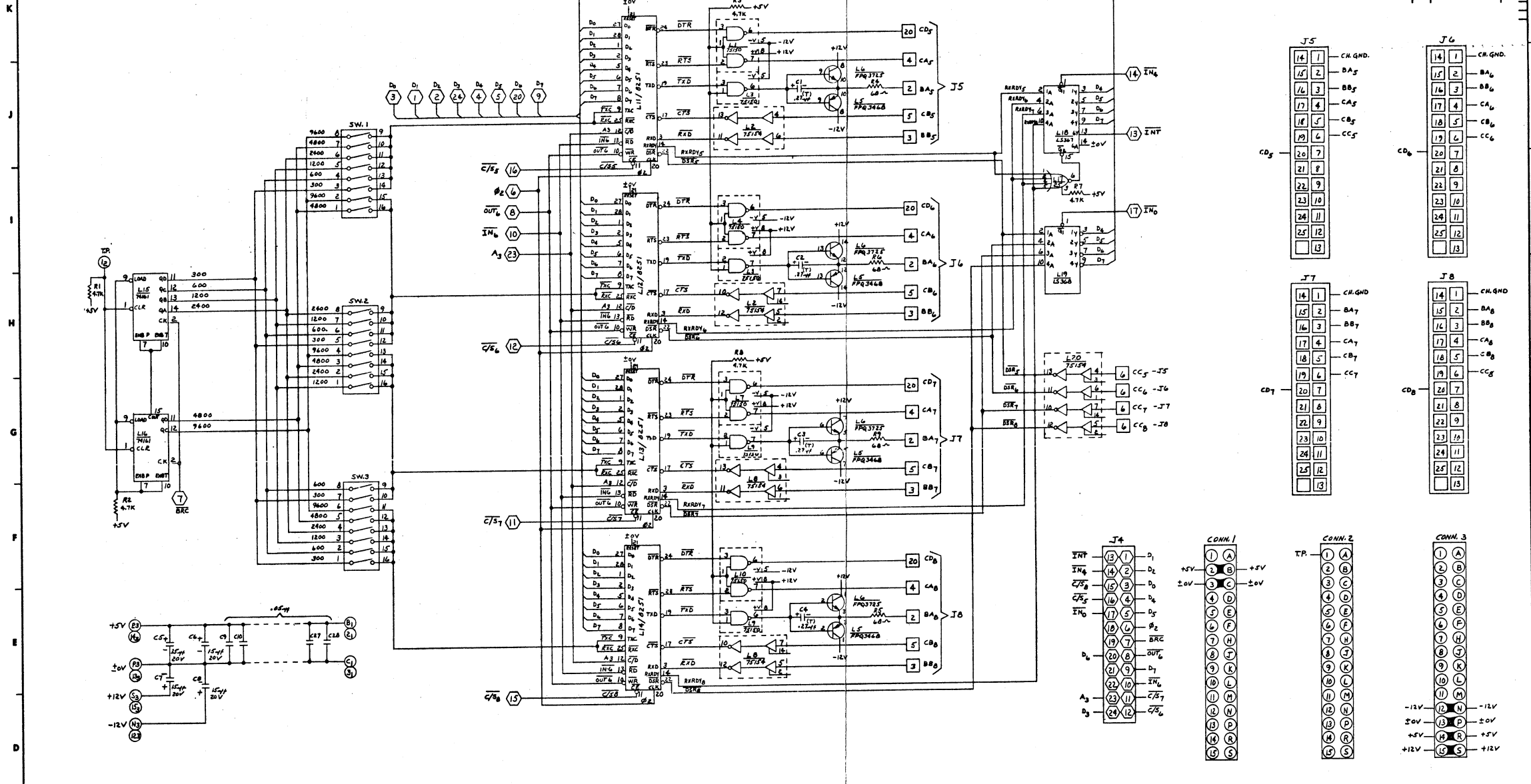

LOCATION	VAL.	PART NO.	QTY	VCC
L3,4,7,10	376-0076	4		
L2,8,20	376-0077	8	15	
L5	376-0187			
L6	376-8106			
L11-M	377-0318	4	20	
L15,16	376-0099	8	16	
L17	376-0092	7	16	
L18	376-0192	8	16	
L19	376-0193	8	16	

LOCATION	TYPE	SPARES
L17	7425	1
L19	7415368	2

COMPONENT	VAL.	PART NO.
L1,2,7,8	330	3047
R4,5,4,9	330	146B
C1,2,3,4	300	4007
C5,6,7,8	300	4022
C9-28	300	1500
L11-14	374	9015
SW1,2,3	315	1503
J4 CABLE ASSEMBLY	220	3029

ECN
NO. PENDING

NO.	DESCRIPTION	DATE	BY
1	DESIGNED BY		
2	DRAWN BY		
3	CHECKED BY		
4	APPROVED BY		
5	DATE		

WANG PART NO.	ITEM	QTY	NAME	MATERIAL	DESCRIPTION
2236			MXC		8080 MXC GRAIND DAUGHTER BOARD

DATE	BY	DATE	APPROVED BY	DATE
6-18-77	ENGR			
	ENGR			
	ENGR			

NO.	DESCRIPTION	DATE	BY
1	DESIGNED BY		
2	DRAWN BY		
3	CHECKED BY		
4	APPROVED BY		
5	DATE		

EDITED BY CUSTOMER ENGINEERING DIVISION

November 29, 1977

ADDENDUM TO SERVICE BULLETIN #80
FOR 2236 INTERACTIVE TERMINAL

This addendum provides clarification of installation and operating procedures for the 2236 Interactive Terminal and 2236 MXC Controller. The sections contained herein replace the original sections of SB #80.

2.2 DEVICE ADDRESS ASSIGNMENTS

2.2.1 2236 MXC-1

The 2236 MXC-1 normally operates at hardwired addresses 001 and 005. These addresses are for the controller board, NOT for a particular terminal.

If the 2236 MXC-1 is to be used with 2236 Terminal #1 as the Console Input/Output device, the MXC-1 will automatically respond to system initialization and display "READY" on Terminal #1.

In many cases, the 2236 Terminals are used in conjunction with a 2226 User Terminal (which is set for Console Input/Output). In this type of configuration, the MXC-1 must be set to something other than 01/05. This is accomplished by setting the 5-bank address switch on the 7290 board of the 2236 MXC-1. Switches 1, 2, or both may be set. Switches 3, 4 and 5 are not used. Switches 1 and 2 set the high-order address bits 40 and 80.

NOTICE:

This document is the property of Wang Laboratories, Inc. Information contained herein is considered company proprietary information and its use is restricted solely to the purpose of assisting you in servicing Wang products. Reproduction of all or any part of this document is prohibited without the consent of Wang Laboratories.

WANG

LABORATORIES, INC.

1 INDUSTRIAL AVENUE, LOWELL, MASSACHUSETTS 01851. TEL. (617) 851-4111, TWX 710 343-6769, TELEX 94-7421

Printed in U.S.A.
13-210.

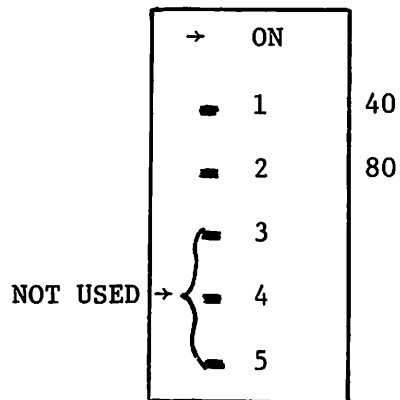

Set switches 1 and 2 OFF for a BOARD address of 01/05.

Set switch 1 ON for a BOARD address of 41/45.

Set switch 2 ON for a BOARD address of 81/85.

Set switches 1 and 2 ON for a BOARD address of C1/C5.

The BOARD address is NOT the same as the Terminal address. Once the BOARD is selected, communication to/from the Terminal can begin by using specific I/O operations as described in Section 3.

2.2.2 2236 MXC-2

No address switches are located on the 7294 controller, as the MXC-2 is controlled by the MXC-1 and cannot be addressed directly.

2.5.2 MODEM CABLES

When using modems, connect the modem cable (220-0113) between the 2236 MXC controller and the modem.

At the remote end, also connect a modem cable (220-0113) between the 2236 Terminal and the modem. DO NOT use the 2236 cable (120-2236 series).

SECTION 3 OPERATION

3.1 GENERAL

In a system using all 2236 Terminals (no 2226 type User Terminal), Console Input/Output is assigned to 2236 Terminal #1. This is set by default and CANNOT be changed. Use of the other 2236 Terminals can only be accomplished under program control.

3.2 ACCESSING THE TERMINALS

3.2.1 GENERAL

As described in section 2.2, the 2236 MXC-1 controller has a BOARD address, used to enable the controller. Once the controller is selected, communication to the terminals is accomplished by specific control sequences using \$GIO or PRINT statements. \$GIO is preferred. Do not confuse the method of selecting the controller with the method of selecting a terminal.

Since most installations use a 2226 as Console Input/Output and the 2236 Terminals for software applications, the method of accessing the terminals in this configuration is described. This method can be used in any configuration, however, by changing the high order address bit in the device select statements.

There are specific control sequences which must be performed in order to communicate with the terminal. The control commands may be sent to the MXC-1 by PRINT statements or \$GIO statements. \$GIO is preferred. IMPORTANT - IF PRINT STATEMENTS ARE USED, THE CONTROL CODES MUST BE FOLLOWED BY A SEMICOLON (;). Otherwise, the MXC-1 will "Hang".

3.2.2 CONTROL CODES

Assume the controller address has switch #1 ON and switches #2 through #5 OFF. This sets the 40 bit ON in the address.

There are five different addresses the MXC-1 controller will respond to for one device address setting. Each has a specific function. With address switch #1 ON, the controller will respond to addresses 042, 043, 044, 046 and 047.

The function of the addresses are:

- 1) 046 - Control Command. SELECT PRINT 046, or \$GIO/046 allows the 2200 program to define which terminal is to be communicated with and what tasks it is expected to perform.

In particular,

- a) Cause the flow of data to be directed to and from a particular terminal (select terminal).
 - b) Cause cursor positioning to be performed.
 - c) Define a line request.
 - d) Cause one or all terminals to be initialized.
- 2) 043 - Receive Terminated Line. SELECT PRINT 043, or \$GIO/043 directs the currently selected terminal to transmit a line of data which was terminated by a Hex (0D).
 - 3) 047 - SEND DATA TO CRT. SELECT PRINT 047, or \$GIO/047 allows characters to be transmitted to and displayed on the CRT of the currently selected terminal.
 - 4) 044 - SEND LINE TO SLAVE PRINTER. SELECT PRINT 044, or \$GIO/044 allows data to be transmitted to and printed on the printer ATTACHED to the currently selected TERMINAL.

- 5) 042 - RECEIVE CONTROLLER STATUS. \$GIO/042 ONLY allows the 2200 to receive 32 bytes of status (4 bytes for each of 8 terminals) from the 2236 MXC-1 controller.

3.2.3 SAMPLE TEST PROGRAMS

In general, when programming the 2200 to communicate with a 2236 Terminal, the first programming statement must be a control command.

10 SELECT PRINT 046	(selects the MXC for a control command)
20 PRINT HEX (F40T);	(selects the terminal described by T. T is from 1 to 8. To select terminal #2, F402 is used.)
30 PRINT HEX (F9);	(Initializes (clears) terminal selected in statement 20)
40 SELECT PRINT 047	(Selects the MXC to receive data from the 2200, transmit and display the data on the CRT of the selected terminal)
50 PRINT "ANY MESSAGE"	(Prints ANY MESSAGE on the CRT of the current selected terminal)

Alternatively, \$GIO could have been used:

```
10 $GIO/046 (40F4 4002 40F9, A$)
40 SELECT PRINT 047
50 PRINT "ANY MESSAGE"
```

3.2.3.1 Outputting Characters to a 2236 Terminal

The following program will fill the CRT of Terminal #2 with X's. (The terminal designation can be changed by changing the "02" in the second microcommand to the number of the terminal desired. In this way, any MXC-1 or MXC-2 connector can be tested even though only one 2236 Terminal is available.):

```

10 $GID/046(40F4 4002 40F9,A$)
50 SELECT PRINT 047: PRINT "XXXXXXXXXXXXXXXXXXXXXXXXXXXXXXXXXXXXXXXXXXXXXXXXXXXX
XXXXXXXXXXXXXXXXXXXXXXXXXXXXXXXXXXXX";
60 GOTO 50

```

3.2.3.2 Input and Output from/to a 2236 Terminal

The following program will select Terminal #3, print a prompt to INPUT CHARACTERS on the terminal, then prefill a line with X's. The pre-filled line of X's will be replaced with the characters you input from the 2236 keyboard. When the line has been filled with the desired characters, key EXECUTE on the 2236. The line of characters you input from the 2236 keyboard will then be transmitted to the 2200 and displayed on the 2226 User Terminal.

TEST 3A

```

0005 DIM W$33,N$33,A$33
0010 $GID/046 (40F4 4003 40F9, A$)
0020 SELECT PRINT 047
0030 PRINT "INPUT CHARACTERS"
0040 $GID/046(4004 4020 4000 4000, A$)
0050 PRINT HEX(08);
0060 $GID/046 (40F7 4002 4000, A$)
0070 PRINT "XXXXXXXXXXXXXXXXXXXX";HEX(0D)
0080 $GID/046(40F5,A$)
0090 $GID/042(C620,A$)W$
      : IF STR(W$,3,1)="0" THEN 90
0095 A$=HEX(0D)
0100 INIT (20) N$
      : $GID/043 (C630,A$) N$
0110 $GID/042 (C620 ,A$) W$
      : IF STR(W$,27,1)<>"0" THEN 110
0120 SELECT PRINT .005
0130 PRINT "2236 INPUT = "; N$
0140 STOP

```

2236 INPUT = OUTPUT FROM 2236

EXPLANATION OF PROGRAM:

5 DIM W\$33, N\$33, A\$33

Dimensions each character string buffer to 33 characters.

10 \$GIO/046 (40F4 4003 40F9, A\$)

Selects the 2236 Terminal plugged into connector 3 of the 2236 MXC-1 (4003) and clears Terminal #3 (40F9).

20 SELECT PRINT 047

Initializes terminal that has been previously selected for output of data.

30 PRINT "INPUT CHARACTERS"

Prompt sent out to selected terminal.

40 \$GIO/046 (4004 4020 4000 4000, A\$)

Code 4004 causes the 2236 MXC-1 to set up and receive a field of 20 characters (4020). A line request has also been initialized.

50 PRINT HEX (08);

Prefill the previous initialized line with the following characters.

60 \$GIO/046 (40F7 4002 4000, A\$)

Position cursor to row 2 (4002) and column 0 (4000) of CRT, this is where you want prefill to begin.

70 PRINT "XXXX....X"; HEX (0D)

Line is prefilled with all X's and carriage return is given.

80 \$GIO/046 (40F5, A\$)

End of line request.

90 \$GIO/042 (C620, A\$) W\$: IF STR(W\$,3,1)="0" THEN 90

Start inputting characters check to see if line is terminated.

95 A\$=HEX (0D)

A\$ is equal to carriage return.

100 INIT (20) N\$: \$GIO/043 (C630, A\$) N\$

2200 receives the inputted characters from the 2236 MXC.

110 \$GIO/042 (C620, A\$) W\$: IF STR(W\$,27,1) "0" THEN 110

Checks to see if buffer is empty, therefore all characters are input.

120 SELECT PRINT 005

Select 2226 for printing.

130 PRINT "2236 INPUT="; N\$

To check any other terminal, change line 10 to:

10 \$GIO/046 (40F4 400X 40F9, A\$)

X=whichever # connector the terminal wanted to be tested is plugged into.

Also line 90,

IF STR(W\$,X,1) = "0"

X = the same X as in line 10

3.2.3.3 Cursor Positioning

The following program will position 2236 cursor of selected terminal to wherever you want.

Again device address is set at 40 on the controller. Also remembering (4002) selects connector #2 of the controller or whatever controller you happen to be testing.

Command code 40F7 sets the 2236 up for cursor positioning. In the program above, the cursor will move 20 rows down (4020) and 10 columns across (4010). Any number from 0-23 rows may be chosen and 0-79 columns.

3.3 DETAILED DESCRIPTION OF COMMAND CODES AND PROGRAMMING SEQUENCES

3.3.1 ADDRESS HEX (06), (46), (B6) OR (C6)

3.3.1.1 Select Terminal Hex (F4XX)

Whenever a command code of F4 is received, the next byte will determine to which terminal communication is to be directed to or received from. The data byte must be a hexadecimal representation of the desired terminal (i.e., 01 = terminal #1, 02 = terminal #2, ..., 08 = terminal #8). For the remainder of this memo, the current terminal is the last SELECTed terminal.

Example, select terminal #1

- a) 10 SELECT PRINT 006
20 PRINT HEX (F401);
or
- b) 10 \$GIO/006 (40F4 4001, Q6\$)

3.3.1.2 Position Cursor HEX (F7XXYY)

A command code of F7 will cause the CRT of the current terminal to be positioned at row XX and column YY. XX and YY must be hexadecimal representation of the desired row or column. The 2236 Interactive Terminal has 24 rows, numbered 0 to 23; and 80 columns, numbered 0 to 79.

Example, position cursor of current terminal at row 10 column 32.

```
10 SELECT PRINT 006
20 PRINT HEX (F70A20);
or
10 DIM R$3
20 R$ = HEX (F7)
30 BIN(STR(R$,2,1)) = 10
40 BIN(STR(R$,3,1)) = 32
50 $GIO/006 (A000, B$) R$
or
10 $GIO/006 (40F7 400A 4020, Q6$)
```

3.3.1.3 Initialize All Terminals HEX (F8)

This command will cause the screens of all terminals to be cleared, and pending requests and input buffer data to be cleared.

Example, clear the screens and buffers of all terminals.

```
10 SELECT PRINT 006
20 PRINT HEX (F8);
or
10 $GIO/006 (40F8, Q6$)
```

3.3.1.4 Initialize Current Terminal HEX (F9)

This command will cause the CRT screen, pending request and input buffer of current terminal, to be cleared.

Example,

```
100 SELECT PRINT 006
110 PRINT HEX (F9);
or
110 $GIO/006 (40F9, Q6$)
```

3.3.1.5 Request Line HEX (03XXAABB)

A command code of 03 will cause the 2236 MXC to setup to receive a field of up to XX characters (a hexadecimal representation of the count, not to exceed 216) starting from the current CRT cursor

position for the currently selected terminal. All field entries will be forced to stay within the field limits. A line request is active until either a carriage return or a special function key is entered. Edit mode may be initiated (BB = 01) or suppressed (BB = 00). The characters previously stored in the keyboard soft buffer may (AA = 01) or may not (AA = 00) be allowed to be treated as entered characters for the line. (In other words, keystrokes received prior to a line request being set, can be either received as part of the line or deleted.) If deleted, they are never echoed back to be displayed on the CRT.

Example, from the current position of the current terminal setup a line request of 20 characters, currently buffered characters may be treated as valid keystrokes and suppress edit mode.

```
10 SELECT PRINT 006
20 PRINT HEX (03140100);
or
10 $GIO/006 (4003 4014 4001 4000, Q6$)
or
10 C$ = HEX (03)
20 BIN(STR(C$,2,1)) = 20
30 STR(C$,3,2) = HEX (0100)
40 $GIO/006 (A000, B$) C$ 1,4
```

There are 4 variations of the line request command. These are programmed in the above manner with only 1 change.

- a) Command 03 - Set up line request echo characters only.
(i.e., no underline)
- b) Command 04 - Set up line request echo characters with underline.
- c) Command 05 - Set up line request echo characters only and initialize field with spaces on CRT.
- d) Command 06 - Set up line request echo characters with underline and initialize the field with underlined spaces on CRT.

3.3.1.6 Initialize Line Request HEX (07XXXX...FF0D)

A command code of 07 is used after a line request command of HEX (03) or HEX (04) to initialize the desired line on the CRT with the supplied characters XXX... starting with the leftmost position in the field. Any non-space characters received are treated as protected characters and are automatically skipped over in entry mode. The string of characters is terminated by a carriage return (0D) or a HEX (FF) code. The cursor is positioned at the leftmost non-protected character.

Example, setup a line request to receive today's data in the form of MM/DD/YY.

```
90 SELECT PRINT 006
100 PRINT HEX (04080000);
110 PRINT HEX (07); " / / "; HEX (0D);
or
110 PRINT HEX (07); " / / "; HEX (FF);
or
110 A$ = " / / ":STR(A$, 9, 1) = HEX (FF)
120 $GIO/006 (4007 A000, Q6$) A$
```

3.3.1.7 PREFILL REQUEST LINE HEX (08XXXX...0D)

A command code of 08 can be sent either after a line request command 03 or 04 or immediately after an Initialize Line Request Command 07 to prefill the desired line with the supplied characters XXX... starting with the leftmost position. The characters are treated as keystrokes and will skip over protected characters, if any exist. The cursor is left at the leftmost non-protected character. The string of characters is terminated by a carriage return, HEX (0D).

Example, initialize today's date as 06/03/77

assuming line request has been made and initialized

```
100 SELECT PRINT 006
110 PRINT HEX (08); "060377"; HEX (0D);
or
110 A$ = "060377":STR(A$, 7, 1) = HEX (0D)
120 $GIO/006 (4008 A000, Q6$) A$
```

3.3.1.8 End of Line Request Sequence HEX (F5)

A special command must be supplied to signal the end of a line request sequence which consists of the setup, any initializes and prefilling desired. Thus a line request, plus any initialization command may be sent out in several statements or as one string of characters in one statement. The last command sent however, must be a HEX (F5), to signal the microcode to invoke the line request.

Example,

assuming setup, initializes and prefill are complete.

```
100 SELECT PRINT 006
110 PRINT HEX (F5);
or
110 $GIO/006 (40F5, Q6$)
```

3.3.2 ADDRESS HEX (07), (47), (87) OR (C7), SEND DATA TO CRT

Address 07 is used to transmit characters to be displayed onto the CRT of the current terminal. Since the CRT output buffer in the controller is limited to 512 characters, it is generally most efficient to send CRT output of blocks 512 bytes or less, waiting for ready (buffer empty) prior to sending the next block. (Or else the CPU will be hung up awaiting the buffer to empty.)

Example,

```
100 SELECT PRINT 007
110 PRINT HEX (030A0A0A0A); TAB (10); "NAME", TAB (30);
"ADDRESS" etc.
```

3.3.3 ADDRESS HEX (04), (44), (84) OR (C4), SEND LINE TO SLAVE PRINTER

Address 04 is similar to address 07 except that the characters are directed to the printer of the current terminal. Print data is sent a line at a time (up to 160 characters). A test for ready

(printer buffer empty) should be made prior to sending out the next print line for efficient operation. (Or else the CPU will be hung up awaiting the buffer to empty.)

Example,

```
100 SELECT PRINT 204
110 PRINT HEX (0C); "NAME"; N$
120 PRINT "ADDRESS"; A$
```

3.3.4 ADDRESS HEX (03), (43), (83) OR (C3), RECEIVE TERMINATED LINE

Address 03 is used to get the data associated with the terminated line request of the currently selected terminal into the 2200. This will be done by a program after a status check indicating a line has been received and terminated. The alphanumeric variable or array setup to receive the line should be sufficiently large to receive the entire line. If it is not, the additional characters will be truncated.

Example,

```
100 $GIO/003 (C620, Q6$) W$ (line terminated with SF Key)
or
100 Q6$ = HEX (0D) (line terminated with SF key or CR)
110 $GIO/003 (C630, Q6$) W$
```

Termination by either a special function key or a special character, HEX (0D), is determined by the 8th byte of the Arg-2 variable, Q6\$.

If the 20-bit is on, termination was by special function key.

If the 40-bit is on, termination was by the special character, HEX (0D).

```
100 AND(STR(Q6$, 8, 1), 60)
110 ON VAL(STR(Q6$, 8, 1)) /32 GOTO 200, 300
.
.
.
200 REM TERMINATED BY SPECIAL FUNCTION KEY
.
.
.
300 REM TERMINATED BY SPECIAL CHARACTER
.
.
.
```

3.3.5 DELETE CURRENT LINE REQUEST HEX (0C)

This command is similar to the initialize current terminal except the CRT screen is not cleared.

Example,

```
100 SELECT PRINT 006
110 PRINT HEX (0C);
or
110 $GIO/006 (400C, Q6$)
```

3.3.6 ADDRESS HEX (02), (42), (82) OR (C2), RECEIVE CONTROLLER STATUS

Address 02 is used to report the statuses of the various buffers to the 2200. When enabled by address 02, the 2236 MXC will send 32 bytes of data and 1 ENDI data byte to be used as a terminator for the input sequence.

<u>Bytes</u>	<u>Buffer</u>	<u>Explanation (HEX Value)</u>
1-8	Line Request	30 - no terminated line request this terminal. 31 - terminated line request this terminal.

<u>Bytes</u>	<u>Buffer</u>	<u>Explanation (HEX Value)</u>
9-16	Terminal On/Off Status	30 - this terminal not powered on. 31 - this terminal powered on.
17-24	CRT	30 - buffer empty this terminal. 31 - buffer not empty this terminal.
25-32	PRINTER	30 - buffer empty this terminal. 31 - buffer not empty this terminal.
33	ENDI Terminator	

Example,

Is the CRT buffer of terminal #4 empty?

```

5 DIM W$ 33
10 $GIO/002 (C620, Q6$) W$
20 IF STR (W$,20,1) = "0" THEN 40
30 GOTO 10
40 REM

```

3.4 MISCELLANEOUS

3.4.1

There are generally three means of communicating with the 2236 MXC. The three methods are:

- 1) \$GIO
- 2) PRINT HEX (
- 3) PRINT ALPHA-VARIABLE OR PRINT USING ALPHA-VARIABLE

\$GIO is the recommended method and must be used if control information is sent out via alpha-variable.

3.4.2 SYSTEM HANG-UP

If system CPU hangs up while running a program and the CPU RESET button will not reset the CPU, the system will have to be powered down and reinitialized.

It is recommended that before running any programs that you don't want to be destroyed, store these programs on disk or storage media available.

An ECN will follow to correct the hangup condition of the CPU.

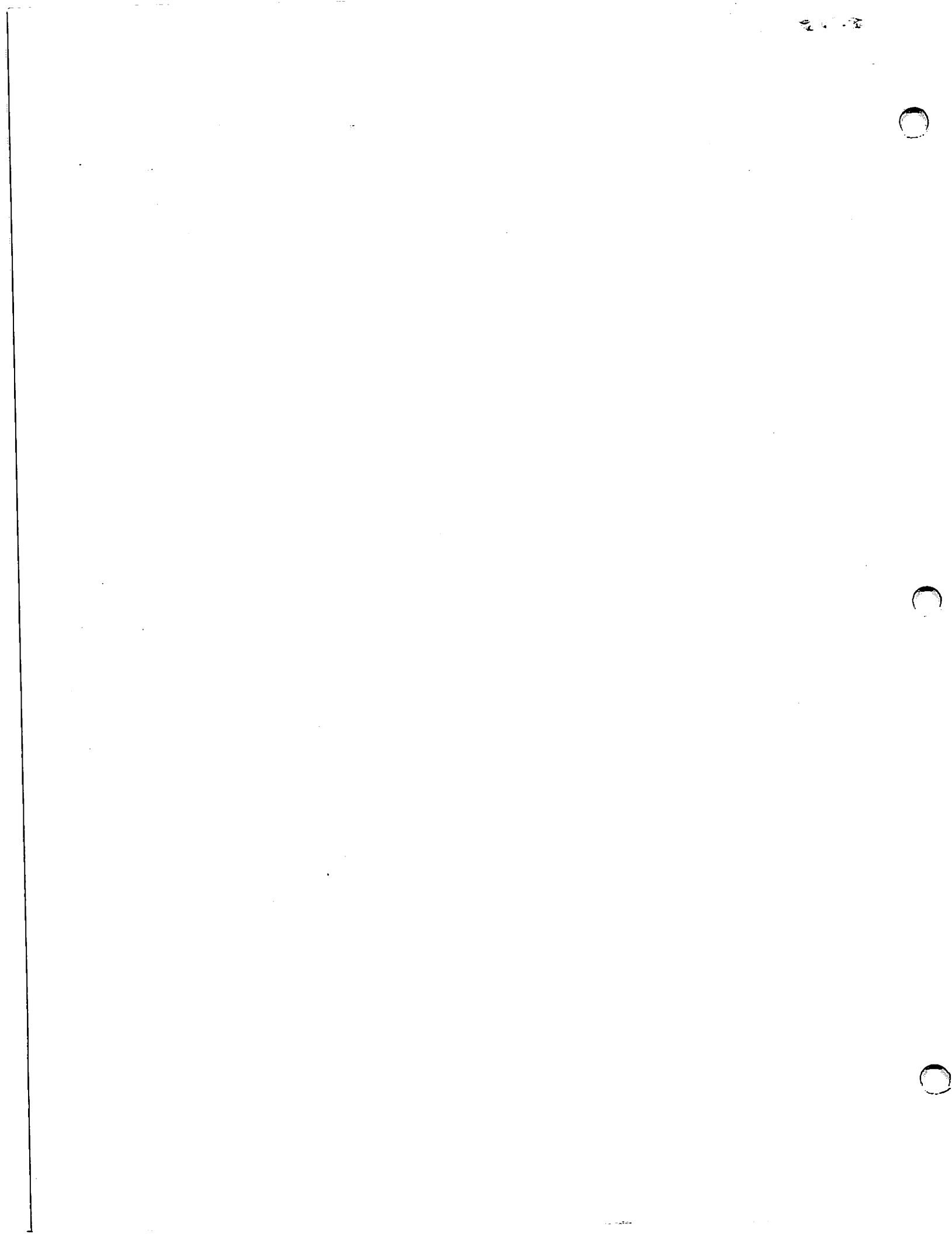

7.3.1 2236 TERMINAL

The terminal can be tested functionally by inserting a "loopback" connector on the rear panel. The loopback connector is an RS-232-C connector with pins 2 and 3 connected together, pins 4 and 5 connected together, and pins 6, 8 and 20 connected together. With the loopback connector installed, keys depressed on the keyboard will be echoed back and displayed on the CRT.

This procedure will not completely check the 2236 Terminal, but will verify that approximately 95% of the 2236 is functioning properly.

10-1-78

