

# WANG FIELD CHANGE ORDER

FCO NO.  
1004

Equipment Affected 2280 AND 6580 PHOENIX DRIVES (BLOCK POINT 3 AND BELOW)  
Class NEXT CALL FCO Kit # 728-0018-25 Page 1 of 9  
Org. Code III.A.7 FCO Doc. # 729-1090 Approval Date:  
Est. Install. Time 45 MINUTES Ref. ECO # CDC# 33779 **JUN 28 1982**

WANG LABS INC. RDB 3110  
New England District (Qty 2)  
ATTN: District Manager

## 1. REASON FOR CHANGE

To provide protection to heads and media in the event of severely restricted air flow or blower motor failure.

## 2. DESCRIPTION OF CHANGE

This change adds an air pressure sensor and associated connecting materials to sense air pressure at the outlet of the absolute filter. If air pressure approaches minimum acceptable operating level, the interlock circuitry will open causing the unit to unload heads and spindle down.

## 3. DOCUMENTATION AFFECTED

Phoenix Hardware Maintenance Manual WL# 729-0198A.

## 4. PREREQUISITE (S)

This change should be installed on Control Data Corporation's series code/block point 2 units S/N 300 to S/N 21,999 and series code/block point 3 units S/N 22,000 to S/N 74,999.

## 5. INSTALLATION PROCEDURE

### CAUTION:

The circuit assemblies contained in this equipment can be degraded or destroyed by ELECTRO-STATIC DISCHARGE (ESD).

Static electrical charges can accumulate quickly on personnel, clothing and synthetic materials. When brought in close proximity to, or in contact with delicate components, ELECTRO-STATIC DISCHARGE OR FIELDS can cause damage to these parts. This damage may result in degraded reliability or immediate failure of the affected component or assembly.

Juct Support <i>6/25/82</i> <u>Donald B. Carson</u>	Logistics <i>6/28/82</i> <u>Kevin Sanders</u>	Originator <i>6/25/82</i> <u>Elaine O'Donnell</u>	FCO Coordinator <i>6/28/82</i> <u>John Prouty</u>
---	---	---	---

**WANG****FIELD CHANGE ORDER**

FCO NO.

1004

Equipment Affected 2280 AND 6580 PHOENIX DRIVES (BLOCK POINT 3 AND BELOW)Class NEXT CALL FCO Kit # 728-0018-25 Page 2 of 9Org. Code III.A.7 FCO Doc. # 729-1090 Approval Date:Est. Install. Time 45 MINUTES Ref. ECO # CDC# 33779 **JUN 28 1982****5. INSTALLATION PROCEDURE (CONT.)**

To insure optimum/reliable equipment operation, it is required that technical support personnel discharge themselves by periodically touching the chassis ground prior to and during the handling of ESD susceptible assemblies. This procedure is very important when handling printed circuit boards.

- A. Perform procedures 6.7.1 and 6.7.2 in the Hardware Maintenance Manual (WL#729-0198A) to gain access to the base pan.
- B. Remove the absolute filter from the base pan and discard.
- C. Install Items 1-13 from FCO Pressure Sensor Kit (for listing of parts see Section 10 - MISCELLANEOUS) as described by this and subsequent paragraphs. Refer to Figure 2. Mount pressure sensor (Item 9) to the sensor bracket (Item 1). Fasten using machine screw (Item 6), washer (Item 7) and hex nut (Item 8). Be sure that spade lugs on sensor (Item 9) are mounted upward as shown in Figure 2.
- D. Refer to Figure 2. Loosen but do not remove the screws at D and E. Remove and save the screw at F.
- E. Install the sensor bracket (Item 1) with attached sensor (Item 9) in the base pan by sliding the bracket under the air deflector at Hole D. Reinstall the screw at F. Tighten the screws D and E.
- F. Refer to Figure 1. Disconnect eight-pin connector OPJ2 from the operator control panel at the left front of the base pan. Extract terminal at OP02-03. Refer to View S, Figure 1. To extract terminal, lift retaining tab slightly using a narrow pointed object such as a small, very thin knife blade, and with a small pull force on the wire, slide the terminal from the connector body. Now refer to Figure 2. Disconnect opposite end of the wire at SW1-0C (deck down switch) located near the electronics module under the left side of the deck. Cut the ends of the disconnected wire and leave in the harness.

# (WANG) FIELD CHANGE ORDER

FCO NO.

1004

Equipment Affected 2280 AND 6580 PHOENIX DRIVES (BLOCK POINT 3 AND BELOW)Class NEXT CALL FCO Kit # 728-0018-25 Page 3 of 9Org. Code III.A.7 FCO Doc. # 729-1090 Approval Date:Est. Install. Time 45 MINUTES Ref. ECO # CDC# 33779JUN 28 1982

## 5. INSTALLATION PROCEDURE (CONT.)

G. Insert the crimped connector end of jumper lead (Item 11) into OPJ2-03 in the same position as the wire removed in Step F. Reconnect OPJ2 to the operator control panel. Route the jumper lead along the left side of the base pan wall using the plastic wire clips for containment. From the second clip on the left wall, route the jumper lead behind absolute filter retaining clip, under the air hose and terminate at the pressure sensor's (Item 9) "B" terminal.

H. Remove the switch mounting bracket\* (see note) and connect "A" jumper lead (item 12) to SW1-0C in the same position as wire removed in Step F. Replace the switch bracket. Route the "A" jumper lead on the bottom the base pan between RFI filter and resistor mounting bracket, and then along the right side of the resistor mounting bracket. TY Wrap (Item 13) to cable bundle at forward edge of bracket. Terminate at the "A" terminal of the pressure sensor (Item 9).

\* NOTE: A mark made on the base deck parallel to the top edge of the switch bracket and level with that surface can serve as a reference point to realign the switch mounting bracket when replacing.

I. Refer to Figure 3 for steps involving items 2, 3, and 4. Insert O-ring (Item 3) into groove of filter fitting (Item 2). Press the O-ring to the bottom of the groove.

J. Insert and seat the air tube (Item 4) into the rim of filter fitting (Item 2).

K. Remove the plug from the left side of the absolute filter.

L. Insert the filter fitting (Item 2) into the hole of the absolute filter where the plug was removed. The filter fitting should fit flush with the filter.

M. Install the absolute filter from kit (WL# 726-6847), into base pan. Exercise care to align filter inlet and air manifold outlet; also take care that the filter is properly positioned in the retaining clip. Cover the filter outlet hole with a sheet of paper to prevent contamination.

N. Refer to Figure 3. Insert set screw (Item 10) 1.00 + or - .12 inches (25.4 + or -3 mm) from one end of air tubing (Item 5).

**WANG****FIELD CHANGE ORDER**

FCO NO.

1004

Equipment Affected 2280 AND 6580 PHOENIX DRIVES (BLOCK POINT 3 AND BELOW)Class NEXT CALL FCO Kit # 728-0018-25 Page 4 of 9Org. Code III.A.7 FCO Doc. # 729-1090 Approval Date:Est. Install. Time 45 MINUTES Ref. ECO # CDC# 33779 JUN 28 1982**5. INSTALLATION PROCEDURE (CONT.)**

- O. Refer to Figure 2. Install the end of the air tubing (Item 5) with the set screw onto the air tube (Item 4). Route the air tubing down to the base pan, around the absolute filter, under the air deflector and over to the pressure sensor (Item 9). Plug on to the stem of the pressure sensor.
- P. Remove the cover from the outlet hole of the absolute filter.
- Q. Lower the deck per manual section 6.7.2. Verify that the deck down switch activates when the deck is lowered. If activation does not occur, adjust per section 6.8.3.3 of the manual.
- R. Make sure that the pre-filter is seated against the gasket on the front of the base pan (bend straight if required).
- S. Cover entire surface of pre-filter with paper. Turn on AC power. Operate the START/STOP switch to start position. The spindle should NOT start rotating. Release the START/STOP switch and turn AC power OFF.
- T. Remove the paper. Remove power to the voice coil by disconnecting its drive power at connector AlP1. Operate the START/STOP switch to start. The spindle should rotate. Allow drive to purge for 20 minutes. Release START/STOP switch and turn AC power OFF.
- U. Reconnect AlP1. Turn on AC power. Operate the START/STOP switch to start unit. With heads loaded at track "0", cover the entire surface of the pre-filter with paper. The heads should unload and the spindle stop rotating.
- V. Log the WANG LABORATORIES FCO# 1004 on the unit FCO log on the side of the electronics module. Insert Figures 1, 2, 3 and the FCO kit parts list (Section 7) behind page 7-8 in the Hardware Maintenance Manual (WL# 729-0198A). Insert page 8 of this FCO in the manual in front of page 7-23 and cross out the old 7-23, but do not remove it as there is valid information on the other side.
- W. Replace the top cover per Manual Section 6.7.1.
- X. Return disk to normal operation.

# WANG FIELD CHANGE ORDER

FCO NO.  
1004

Equipment Affected 2280 AND 6580 PHOENIX DRIVES (BLOCK POINT 3 AND BELOW)

Class NEXT CALL FCO Kit # 728-0018-25 Page 5 of 9

Org. Code III.A.7 FCO Doc. # 729-1090 Approval Date:

Est. Install. Time 45 MINUTES Ref. ECO # CDC# 33779 **JUN 28 1982**

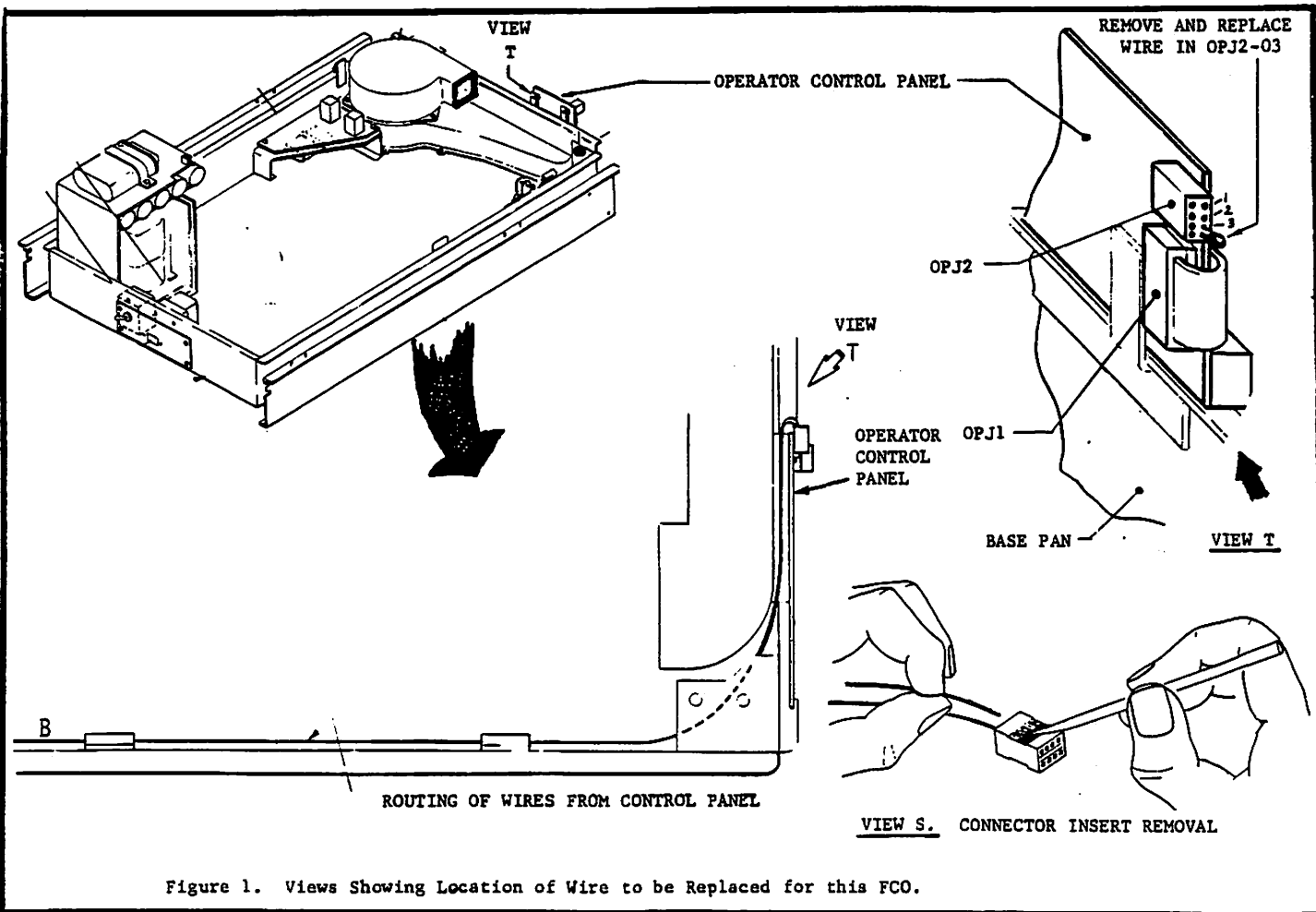

Figure 1. Views Showing Location of Wire to be Replaced for this FCO.

# WANG FIELD CHANGE ORDER

FCO NO.  
1004

Equipment Affected 2280 AND 6580 PHOENIX DRIVES (BLOCK POINT 3 AND BELOW)

Class NEXT CALL FCO Kit # 728-0018-25 Page 6 of 9

Org. Code III.A.7 FCO Doc. # 729-1090 Approval Date:

Est. Install. Time 45 MINUTES Ref. ECO # CDC# 33779 **JUN 28 1982**

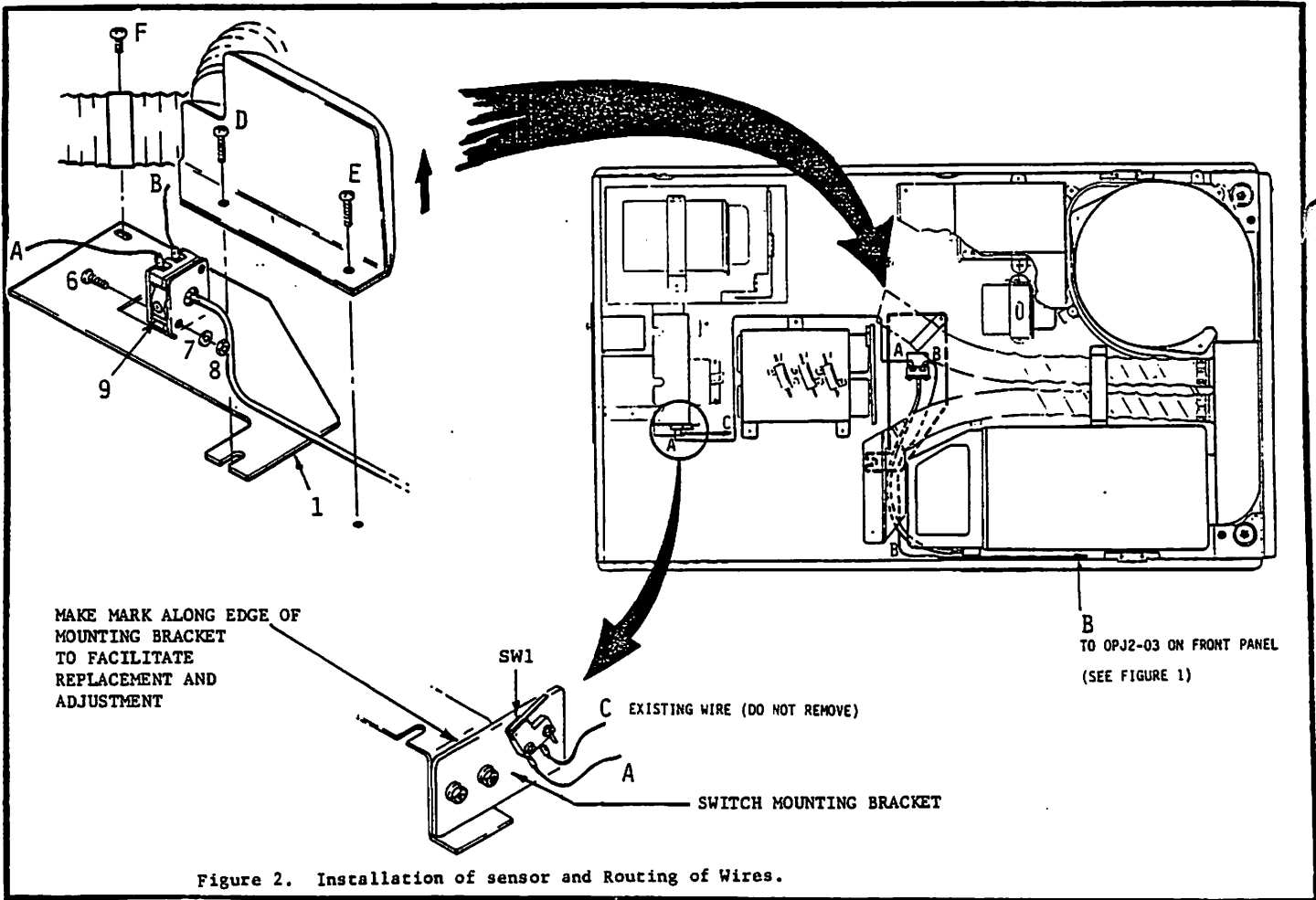

**WANG**

# FIELD CHANGE ORDER

FCO NO.
1004

Equipment Affected 2280 AND 6580 PHOENIX DRIVES (BLOCK POINT 3 AND BELOW)

Class NEXT CALL FCO Kit # 728-0018-25 Page 7 of 9

Org. Code III.A.7 FCO Doc. # 729-1090 Approval Date:

Est. Install. Time 45 MINUTES Ref. ECO # CDC# 33779 **JUN 28 1982**

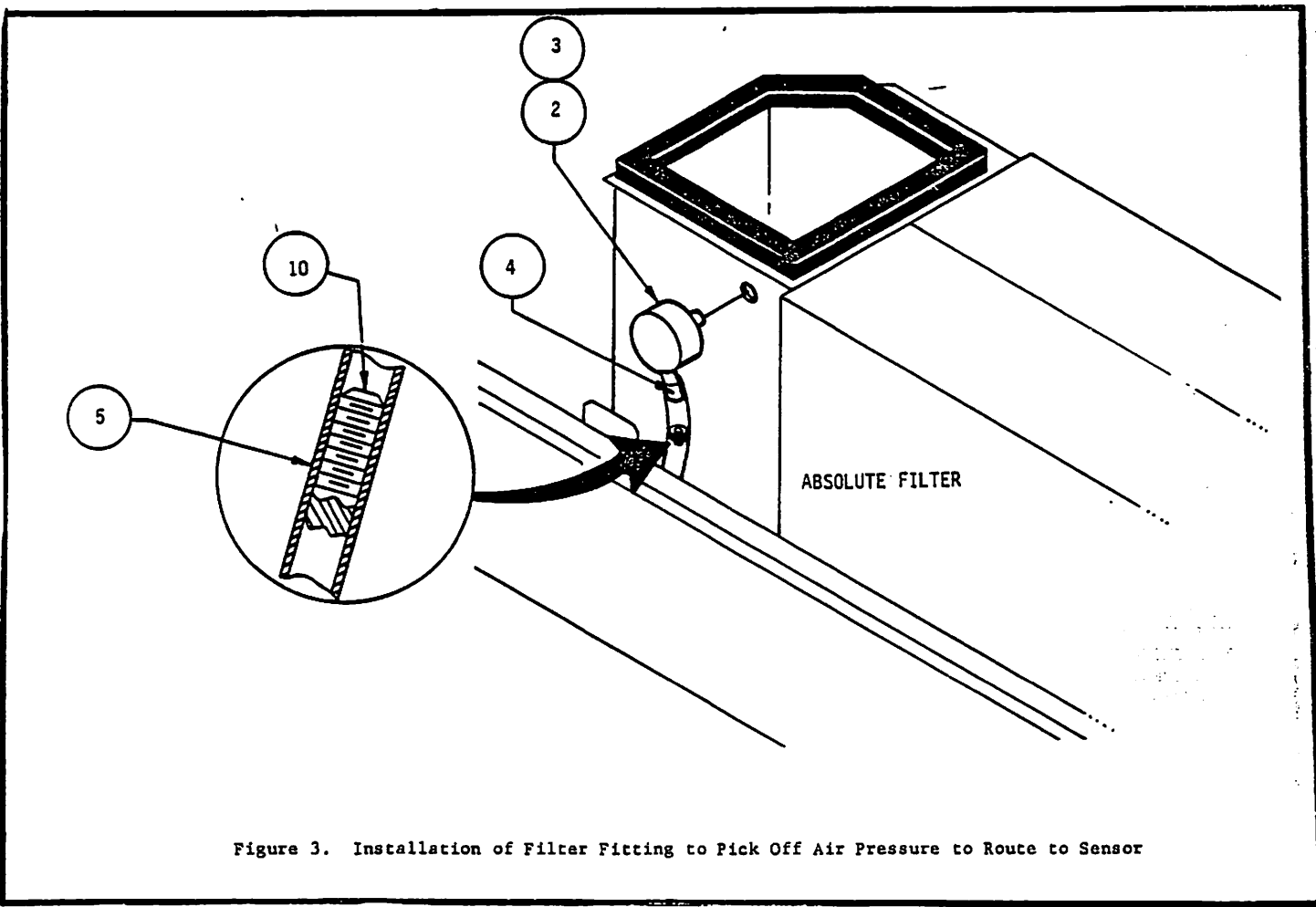

Figure 3. Installation of Filter Fitting to Pick Off Air Pressure to Route to Sensor

# WANG FIELD CHANGE ORDER

FCO NO.  
1004

Equipment Affected 2280 AND 6580 PHOENIX DRIVES (BLOCK POINT 3 AND BELOW)

Class NEXT CALL FCO Kit # 728-0018-25 Page 8 of 9

Org. Code III.A.7 FCO Doc. # 729-1090 Approval Date:

Est. Install. Time 45 MINUTES Ref. ECO # CDC# 33779 **JUN 28 1982**

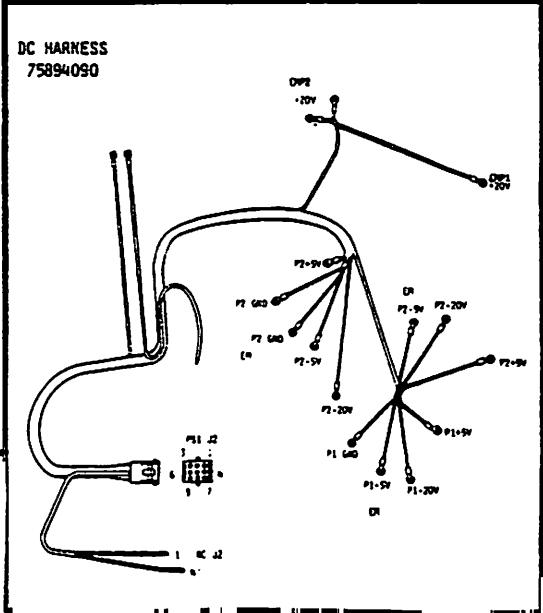
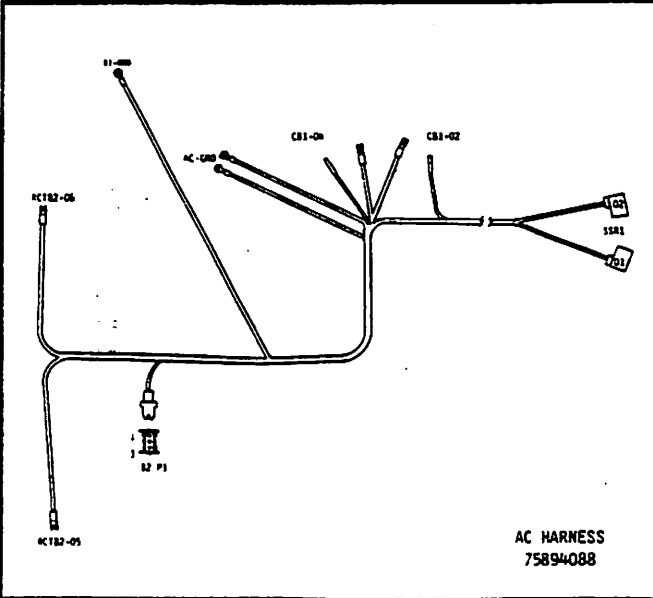
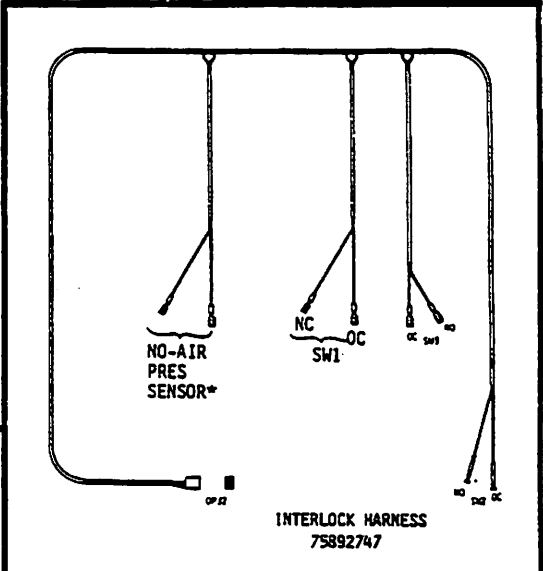
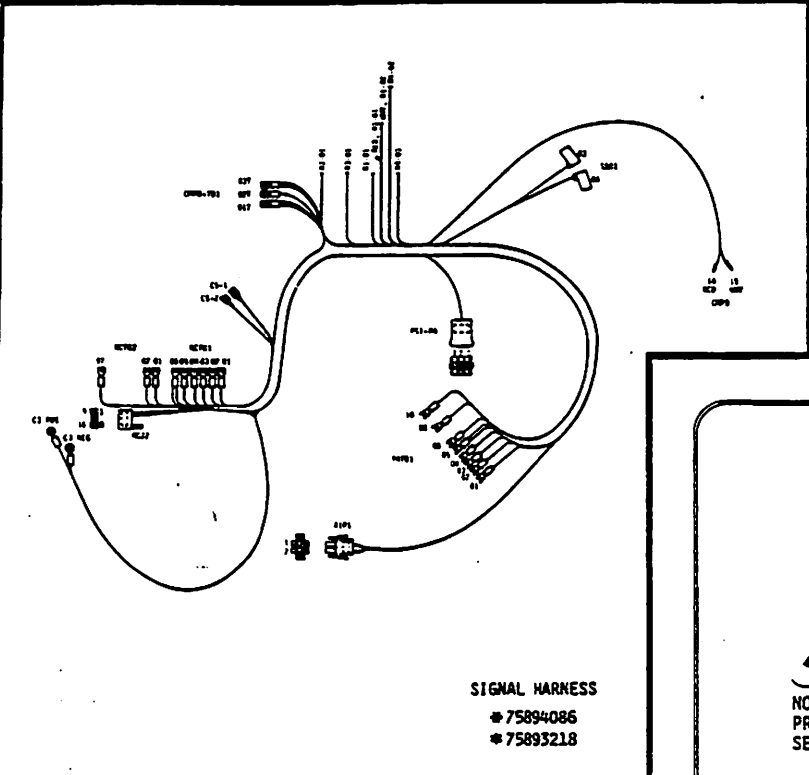

FIGURE 7-21. CMD HARNESSES



# (WANG) FIELD CHANGE ORDER

FCO NO.
1004

Equipment Affected 2280 AND 6580 PHOENIX DRIVES (BLOCK POINT 3 AND BELOW)

Class NEXT CALL FCO Kit # 728-0018-25 Page 9 of 9

Org. Code III.A.7 FCO Doc. # 729-1090 Approval Date:

Est. Install. Time 45 MINUTES Ref. ECO # CDC# 33779 **JUN 28 1982**

## 6. CHECK-OUT PROCEDURE

- A. See Steps R through U of Section 5 above.
- B. Depress "START" button on operator's control panel. "READY" light will indicate proper installation of this change.

## 7. FCO KIT PARTS LISTING

Item #	Item Description
WL# 729-1090	FCO# 1004
WL# 726-6846	Filter, Air Fine
WL# 726-6847	Pressure Sensor Kit

## 8. FCO KIT AVAILABILITY DATE

FCO Kit# 728-0018-25 will be available August 13, 1982. It can be obtained by placing a routine order through the Logistics Order Processing System. See MISCELLANEOUS "NOTE" - Section 10.

## 9. REMOVED PARTS DISPOSITION

Removed parts should be scrapped.

## 10. MISCELLANEOUS

Item	CDC ID Number	Title	Qty
1	77643194	Bracket, Sensor	1 ea
2	75899165	Fitting, Filter	1 ea
3	92074007	O-Ring	1 ea
4	77649250	Air Tube	1 ea
5	77668546	Air Tubing	1 ea
6	10127170	Screw, Mach Pan	2 ea
7	10126100	Washer	2 ea
8	10125102	Nut, Hex	2 ea
9	77619634	Sensor Press	1 ea
10	92006029	Screw, Set (one spare)	2 ea
11	77664315	Jumper Leads (34 in.)	1 ea
12	77664316	Jumper Leads (15 in.)	1 ea
13	94277400	Ty Wrap	2 ea

NOTE: This change may decrease normal demand for filters required for Preventative Maintenance.

CUSTOMER ENGINEERING  
TECHNICAL ASSISTANCE CENTER  
NEWSLETTER

#40221

3105

PERIPHERALS-DISK DRIVES-CDC PHOENIX

TOPIC: PHOENIX CENTER RAIL TORQUE SPECIFICATION

We have had reports of the center rail becoming loose and causing head crashes. The screw holding the rail is supposed to be lock-tited. If you have a rail come loose, place lock tite (P/N 660-0194) on the threads and torque to 1.25 inch pounds, (which is almost finger tight). Refer to manual 729-0198B, page 6-36, section 6-7-19 for instructions.

Caution: If you over torque the center rail, the alignment will be affected and you may not be able to get it within specifications.

CUSTOMER ENGINEERING  
TECHNICAL ASSISTANCE CENTER  
NEWSLETTER

#41023

3105

PERIPHERALS-DISK DRIVES-CDC PHOENIX

TOPIC: FUNCTION OF BLOCK POINT 4 JUMPERS IN SERVO COURSE BOARD

The purpose of this newsletter is to clarify the function of the selectable jumpers in the center of the servo course board, Wang part number 726-5780, CDC part # 77682950. There are a total of four selectable pins. Positions 1 and 2 are for changing the purge time on power up. With the jumper for pins 1 and 2 removed, the optional 120 second purge is selected. With the jumper in place, the normal purge is selected.

Pins 3 and 4 monitor loss of Automatic Gain Control (AGC). With this jumper in place and a loss of AGC is sensed, the heads will unload and a seek error code will be set. To recover, an operator can clear via the operators panel or issue an Return To Zero (RTZ) command. The drive can then be restarted or the pack removed from the drive.

With the jumper removed and loss of AGC is sensed, the drive will be dead! The operator will not be able to clear the error from the operator panel or by issuing an RTZ command. The cartridge receiver door will be locked, preventing anyone from removing the cartridge. This is a safety feature designed to prevent an operator from propagating a head crash to other drives. The only way to clear this condition is to power the drive off and on.

Drives are currently being shipped with both jumpers installed.

CUSTOMER ENGINEERING  
TECHNICAL ASSISTANCE CENTER  
NEWSLETTER

#40313

3105

PERIPHERALS-DISK DRIVES-CDC PHOENIX

TOPIC: PHOENIX SERVO COARSE PCB'S CORRECTED JUMPER SETTINGS  
FROM TAC N/L 40306, CATEGORY 3105, TOPIC: SAME

Due to incorrect information, the above mentioned N/L was in error. The disable jumper was mis-stated as being the load timing jumper. The correct jumper settings are stated below. We are sorry for any inconvenience this may have caused.

There is a new servo Coarse PCB CDC #77682950 that is being shipped with the new units. It is completely compatible with the other Servo Coarse PCB's (726-5780).

This new Servo Coarse board has a jumper (J1) located near the right hand PCB extractor lever. This jumper is for the Servo Disable. With the jumper to the left side, the Servo is disabled; with the jumper to the right side, the Servo is enabled.

The Head load timing jumper (J2 4 pin) is located in the middle of the PCB between U22 and U27

This delay was incorporated to allow extra purge and stabilization time for the cartridge; the lower particle count can reduce head crashes.

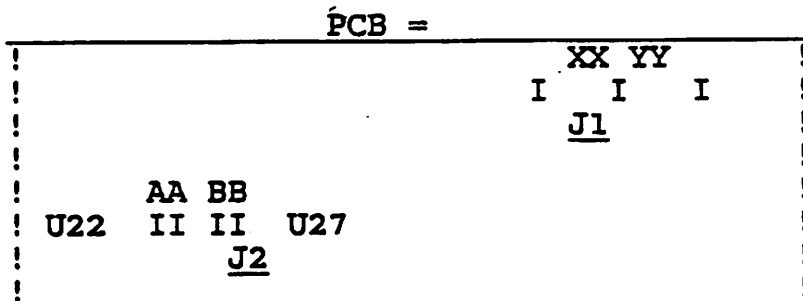

XX= Disabled, YY= Enabled

AA= 120 Seconds, BB= 90 Seconds

CUSTOMER ENGINEERING  
 TECHNICAL ASSISTANCE CENTER  
 NEWSLETTER

#41120

3105

PERIPHERALS-DISK DRIVES-CDC PHOENIX

TOPIC: CMD CONTROL-MUX ERROR CONDITIONS

The "ERROR" and "ACTION" items on the following pages represent possible solutions to drive problems. They are not to be construed as a guarantee to all problems, but to be used as a guide to problem resolution.

The "PHASE" and "FAULT" indications are derived from the MICRO-PROCESSOR on the CONTROL-MUX PCB, LED's CR3 through CR7. A description and explanation on its use is shown in section 6, tables 6-6, 6-7 and 6-8 in the CMD maintenance manual. "PHASE" represents the phase of operation the drive was in when it acquired a "FAULT".

! PHASE !	! FAULT !	! ERROR DESCRIPTION !	! ACTION !
	10	Spindle start greater than 70 seconds.	<u>PRIMARY:</u> 1)Check drive belt. 2)Replace motor starter capacitor. 3)Replace Solid State Relay.
	0F	Spindle did not start/ stop in 2 minutes after ERSLO/ERSTP was noted.	<u>PRIMARY:</u> 1)Same as fault 10. <u>SECONDARY:</u> a)Check Relay Control PCB and cabling.
	11	No spindle movement.	<u>PRIMARY:</u> 1)Replace Servo Coarse 2)Replace Relay Cntrl 3)Replace Solid State Relay. <u>SECONDARY:</u> a)Check Speed Sensor
	12	No drive to solid state relay.	<u>PRIMARY:</u> 1)Replace Servo Coarse 2)Replace Relay Cntrl <u>SECONDARY:</u> a)Check cabling b/w PCB's and SSR.
	13	Solid state relay failure.	<u>PRIMARY:</u> 1)Replace Solid State RELAY. 2)Replace Servo Coarse 3)Replace Relay Ctl

CUSTOMER ENGINEERING  
TECHNICAL ASSISTANCE CENTER  
NEWSLETTER

#41120

3105

PERIPHERALS-DISK DRIVES-CDC PHOENIX

TOPIC: CMD CONTROL-MUX ERROR CONDITIONS (continued)

PHASE	FAULT	ERROR DESCRIPTION	ACTION
	14	Stop Timeout.	<u>PRIMARY:</u> 1)Replace Servo Coarse 2)Check drive belt 3)Check Relay Control
	15	Emergency retract failure.	<u>PRIMARY:</u> 1)Replace Power Amp
	1D	Allowed time expired.	2)Replace Servo Coarse
	16	Normal retract failure	<u>PRIMARY:</u> 1)Replace Power Amp 2)Replace Servo Coarse
	17	Cylinder address greater than 822.	<u>PRIMARY:</u> 1)Replace I/O 2)Replace Servo Coarse <u>SECONDARY:</u> a)Check host IOP and software.
	1B	RPM fault.	<u>PRIMARY:</u> 1)Check Speed Sensor 2)Check Motor, Pulley, Belt. 3)Replace Servo Coarse 4)Replace SSR.
	1C	Lost speed pulses.	<u>PRIMARY:</u> 1)Replace Speed Sensor 2)Replace Servo Coarse 3)Check Sensor cabling
	1D	Allowed time expired.	<u>PRIMARY:</u> 1)Replace Servo Coarse 2)Replace Power Amp
01	1D	Return to track center Allowed time expired. (80 MS).	<u>PRIMARY:</u> 1)Replace Servo Coarse 2)Replace Servo Fine 3)Replace Power Amp

CUSTOMER ENGINEERING  
 TECHNICAL ASSISTANCE CENTER  
 NEWSLETTER

#41120

3105

PERIPHERALS-DISK DRIVES-CDC PHOENIX

TOPIC: CMD CONTROL-MUX ERROR CONDITIONS (continued)

PHASE	FAULT	ERROR DESCRIPTION	ACTION
02	1A	Wait for coarse seek completion. Lost AGC.	<u>PRIMARY:</u> 1)Possible head crash. Inspect heads and media. 2)possible bad servo head. <u>SECONDARY:</u> a)Replace Servo Coarse b)Replace Servo Fine c)Replace Power Amp d)Replace Cartridge
02	1D	Wait for coarse seek completion. Allowed time expired.	<u>PRIMARY:</u> 1)Same as SECONDARY of 02-1A. <u>SECONDARY:</u> a)Check bearing plate b)Check bearings c)Check rail
03	1A	After seek settling. Lost AGC.	<u>PRIMARY:</u> 1)Same as SECONDARY of 02-1A
03	1D	After seek settling. Allowed time expired. (80 ms)	<u>PRIMARY:</u> 1)Same as SECONDARY of 02-1A.
03	1E	After seek settling. No track lock in settling.	<u>PRIMARY:</u> 1)Same as 02-1D <u>SECONDARY:</u> a)Same as 02-1D
03	1D 1E	After seek settling. Allowed time expired. No track lock in settling.(80 ms)	<u>PRIMARY:</u> 1)Same as 02-1D. <u>SECONDARY:</u> a)Same as 02-1D.
04	18	Idle loop. Off track greater than 1200 u sec.	<u>PRIMARY:</u> 1)Same as 02-1D. <u>SECONDARY:</u> a)Same as 02-1D.

CUSTOMER ENGINEERING  
 TECHNICAL ASSISTANCE CENTER  
 NEWSLETTER

#41120

3105

PERIPHERALS-DISK DRIVES-CDC PHOENIX

TOPIC: CMD CONTROL-MUX ERROR CONDITIONS (continued)

PHASE	FAULT	ERROR DESCRIPTION	ACTION
04	1A	Idle loop. Lost AGC.	<u>PRIMARY:</u> 1)Replace Servo Fine 2)Replace Servo Coarse 3)Replace Servo Preamp 4)Replace Power Amp <u>SECONDARY:</u> a)Check Servo Head b)Check cables b/w Preamp & Fine PCB c)Check Velocity Transducer.
04	1B	Idle loop. RPM fault.	<u>PRIMARY:</u> 1)Replace Servo Coarse 2)Replace Servo Fine <u>SECONDARY:</u> a)Check Motor/Belt.
04	18 1E	Idle loop. Off track GT1200 u sec No track lock in settling.	<u>PRIMARY:</u> 1)Same as 02-1D. <u>SECONDARY:</u> a)Same as 02-1D.
05	1D	Return to zero motion. Allowed time expired. (500 ms)	<u>PRIMARY:</u> 1)Replace Servo Coarse 2)replace Power Amp 3)Check Voice Coil and cabling.
06		End of velocity table.	<u>PRIMARY:</u> 1)Replace Servo Coarse
06	1A	End of velocity table. Lost AGC.	<u>PRIMARY:</u> 1)Replace Servo Coarse 2)Replace Servo Fine 3)Replace Servo Preamp
06	1D	End of velocity table. Allowed time expired. (80 ms)	<u>PRIMARY:</u> 1)Replace Servo Coarse 2)Replace Servo Fine <u>SECONDARY:</u> a)Check Bearing Plate b)Servo Head Alignment c)Carriage Bearings d)Rail



CUSTOMER ENGINEERING  
 TECHNICAL ASSISTANCE CENTER  
 NEWSLETTER

#41120

3105

PERIPHERALS-DISK DRIVES-CDC PHOENIX

TOPIC: CMD CONTROL-MUX ERROR CONDITIONS (continued)

PHASE	FAULT	ERROR DESCRIPTION	ACTION
07		Head load.	<u>PRIMARY:</u> 1)Replace Servo Coarse 2)Replace Power Amp 3)Replace Relay Cntrl
08		Await AGC during head load.	<u>PRIMARY:</u> 1)Replace Servo Fine 2)Replace Servo Coarse 3)Replace Servo Preamp <u>SECONDARY:</u> a)Check Servo Head and Cable.
08	1D	Await AGC during head load. Allowed time expired. (300 ms)	<u>PRIMARY:</u> 1)Replace Servo Fine 2)Replace Servo Preamp <u>SECONDARY:</u> a)Check Servo Head and Cable.
09		Await track center-load or RTZ.	<u>PRIMARY:</u> 1)Replace Servo Coarse 2)Replace Servo Fine <u>SECONDARY:</u> a)Check Servo Head and Cable. b)Check Velocity Transducer.
09	1D	Await track center-load or RTZ. Allowed time expired. (300 ms)	<u>PRIMARY:</u> 1)replace Servo Fine 2)Replace Servo Coarse 3)replace Servo Preamp <u>SECONDARY:</u> a)Same as Phase 09
0A		Settling-load or RTZ.	<u>PRIMARY:</u> 1)Same as 09-1D <u>SECONDARY:</u> a)Same as 09-1D
0A	1A	Settling-load or RTZ. Lost AGC.	<u>PRIMARY:</u> 1)Same as 09-1D <u>SECONDARY:</u> a)Same as 09-1D

CUSTOMER ENGINEERING  
 TECHNICAL ASSISTANCE CENTER  
 NEWSLETTER

#41120

3105

PERIPHERALS-DISK DRIVES-CDC PHOENIX

TOPIC: CMD CONTROL-MUX ERROR CONDITIONS (continued)

PHASE	FAULT	ERROR DESCRIPTION	ACTION
0B		Offset active.	<u>PRIMARY:</u> 1) Replace Servo Coarse 2) Replace Servo Fine 3) Replace Servo Preamp 4) Replace Power Amp <u>SECONDARY:</u> a) Check Voice Coil and associated cabling. b) Check servo head and cabling. c) Check Velocity Transducer.
0B	1A	Offset active. Lost AGC.	<u>PRIMARY:</u> 1) Same as Phase 0B <u>SECONDARY:</u> a) Same as Phase 0B
0C		Clear offset settling.	<u>PRIMARY:</u> 1) Same as Phase 0B <u>SECONDARY:</u> a) Same as Phase 0B
0C	1A	Clear offset settling. Lost AGC.	<u>PRIMARY:</u> 1) Same as Phase 0B <u>SECONDARY:</u> a) Same as Phase 0B

WANG

TECHNICAL SERVICE BULLETIN  
SECTION: HardWare Technical

NUMBER: HWT 5131 REPLACES: N/A DATE: 07/02/85 PAGE 1 OF 1

MATRIX ID. 3105 PRODUCT/RELEASE# 2280/6580/2280V

TITLE: FIXED MODULE REPLACEMENT (WLN 726-6506)

PURPOSE:

To inform field personnel of possible fixed module difficulties.

EXPLANATION:

Approximately 60 defective fixed modules were delivered by Magnetic Data to Wang. The servo signals were written incorrectly, by five tracks, from the correct location. The problem was caused by a process error during March and April. Logistics is working with Magnetic Data to purge all field stock.

To recognize these fixed modules the CE, after replacing a fixed module, will have problems performing the head alignment in the drive. The CE will be unable to locate the alignment signals on the CE alignment cartridge with the head tool. The servo signal in the defective fixed modules is recorded in the incorrect location, which creates difficulty in aligning the heads of the removable cartridge. These fixed modules are under warranty. Currently the serial numbers of the defective modules are unknown.

In case of an emergency these fixed modules can be used by the field. The CE alignment cartridge signals can be reached by moving the heads (the servo and data heads) with a screwdriver. These fixed modules will then operate without any problem.

To return the recalled fixed modules contact Diana Nelson in Wang Purchasing (Tel. 617-794-6830 or FAX 617-794-7045). The information required from the field is quantities of recalled modules, serial numbers of the modules, branch address or country, and person to contact.

Purchasing will supply the field with the vendor return authorization number, the debit number, the shipping address and the instructions on how to prepare the material for shipment. The vendor will drop ship the replacement fixed modules to your location after they receive the recalled fixed modules from you.

GROUP: Peripheral Hardware Support Group MAIL STOP: 0125

COMPANY CONFIDENTIAL

WANG Laboratories, Inc.

TECHNICAL SERVICE BULLETIN  
SECTION: HardWare Technical

NUMBER: HWT 7029 REPLACES: \_\_\_\_\_ DATE: 02/24/87 PAGE 1 OF 1  
MATRIX ID. 3105 PRODUCT/RELEASE# CDC Phoenix (2280)  
TITLE: Cartridge Release Shaft (WLI #726-1398)

PURPOSE:

To inform the field of a potential problem with the old style cartridge release shaft on the CDC Phoenix Disk Drive (Model 2280), and make the field aware of the new style shaft assembly (WLI #726-1398).

EXPLANATION:

There is a potential problem in the CDC Phoenix Disk Drive with the Cartridge Release Shaft assembly (CDC Cartridge Module Drive Manual WLI #741-1063 page 7-8, figure 7-4; items 471, 472 & 473). The problem is with the plastic bearing and spacers on the end of the shaft. Over a period of time, the plastic can crack from the heat generated inside the drive and also from the force of hitting the bottom of the cartridge each time the door is opened to remove the cartridge. With the cracking of the plastic, pieces could find their way into the fixed module area and damage the platters. This could possibly lead to a head crash if enough damage is done.

The old style plastic bearings and spacers are on the BP3 (Block Point 3) and possibly some of the early BP4 (Block Point 4) models and are white in color. The new style shaft assembly has a dark brown nylon bearing with a washer and "C" clip to hold it on the shaft.

This assembly (bearing and spacers) should be checked for signs of wear on a next call basis and replaced if necessary. The new assembly can be ordered through Logistics using WLI #726-1398 and can be used on the BP4 as well as the BP3 drives.

GROUP: Desktop Systems/Peripherals Group MAIL STOP: 001-140

COMPANY CONFIDENTIAL  
WANG Laboratories, Inc.



TECHNICAL SERVICE BULLETIN  
SECTION: HardWare Technical

NUMBER: HWT 7021 REPLACES: \_\_\_\_\_ DATE: 03/10/87 PAGE 1 OF 2

MATRIX ID. 3105 PRODUCT/RELEASE# PHOENIX

TITLE: Phoenix board compatibility

PURPOSE:

To make the field aware of possible compatibility issues with Phoenix boards.

EXPLANATION:

Several calls have been received by On Line Product Support from the field concerning compatibility with Phoenix boards. The boards in question are: the I/O, the Control Mux, and the Servo Coarse. For the most part these boards should be upward and downward compatible. If experiencing a problem two general rules may help:

1. Avoid using the early version boards in the Blockpoint 4 drives (identified by pluggable harness on power amp and relay board) due to timing differences with Wang controllers. (See boards noted with single \* from list.)
2. Avoid intermixing the new I/O Board (726-6669), the new Control Mux (726-6668), and the Servo Coarse (726-6887) with older version boards. (See boards noted with \*\* from list.)

The following list contains most of the CDC part numbers associated with the I/O boards, the Control Mux boards, and the Servo Coarse boards used by Wang Labs.

I/O Board 726-5778

- \* 75891850 series code 2 (unique to Wang)
- \* 77616751 series code 2/3 (unique to Wang)
- 77616770A
- 77616790
- 77622500-1 series code 3 (universal)

I/O Board 726-6669

- \*\* 77665650 series code 4 (universal)

Control Mux 726-5779

- 77616600
- 77624700

Control Mux 726-6668

- \*\* 77666950

OVER

GROUP: VS/2200/PC On Line Hardware Support Group MAIL STOP: 001-260

COMPANY CONFIDENTIAL

WANG Laboratories, Inc.



TECHNICAL SERVICE BULLETIN  
SECTION: HardWare Technical

NUMBER: HWT 7021 REPLACES: \_\_\_\_\_ DATE: 03/10/87 PAGE 2 OF 2  
MATRIX ID. 3105 PRODUCT/RELEASE# PHOENIX  
TITLE: Phoenix board compatibility

Servo Coarse 726-5780  
\* 75885600  
77622400/01/02/03  
77622420  
77622750  
77666800/01

Servo Coarse 726-6887  
\*\* 77682950 has jumpers J1 (top rt) & J2  
(between U22 and U27)  
set J1 in (loss of AGC recoverable  
without power down)  
set J2 out (120 sec purge)  
in (90 sec purge)

NOTE: THE NEWER REV BOARDS ARE VERY SIMILAR TO THE OLDER VERSION  
BOARDS. BOARDS IN STOCK COULD BE MIXED. IF A PARTICULAR REV  
BOARD IS NEEDED, VERIFY THE REV WHEN TAKEN FROM STOCK. WHEN  
ORDERING BOARDS- SPECIFY THE CDC NUMBER AND VERIFY CORRECT UPON  
RECEIPT.

ADDITIONAL INFORMATION:

There are 3 different Relay Boards for the Phoenix. Two of the boards are for Blockpoint 4 drives (pluggable terminal strip). If replacing a Relay Board in a Blockpoint 4 drive, the same type Relay Board should be used as identified by the CDC part number on the board. Do not replace one type with another.

Blockpoint 3 Relay Board  
726-5786 CDC # 75898850/77634490

Blockpoint 4 Relay Boards  
726-6724 CDC # 77680650  
726-6724A CDC # 77713900 726-6767

GROUP: VS/2200/PC On Line Product Support Group MAIL STOP: 001-260

COMPANY CONFIDENTIAL  
WANG Laboratories, Inc.

TECHNICAL SERVICE BULLETIN  
SECTION: HardWare Technical

NUMBER: HWT 7087 REPLACES: HWT 7021 DATE: 05/05/87 PAGE 1 OF 2  
MATRIX ID. 3105 PRODUCT/RELEASE# PHOENIX  
TITLE: Phoenix board compatibility

PURPOSE:

To clarify information supplied in TSB 7087 by further identification of the boards which could present compatibility issues with the Phoenix.

EXPLANATION:

Several calls have been received by On Line Product Support from the field concerning compatibility with Phoenix boards. The boards in question are: the I/O, the Control Mux, and the Servo Coarse. For the most part these boards should be upward and downward compatible. If experiencing a problem the following may help:

1. Avoid using the early version boards in the Blockpoint 4 drives due to timing differences. Blockpoint 4 drives can be identified by the pluggable harness on the power amp and relay board. Early version boards are noted with a single \* in the list.
2. Avoid intermixing the new I/O Board (726-6669), the new Control Mux (726-6668), and the new Servo Coarse (726-6887) with other versions of these same type boards. The new I/O, Control Mux, and Servo Coarse boards are noted with \*\* in the list.
3. Those boards without asterisks are upward and downward compatible to all drives but should not be used with the new I/O, Control Mux, and Servo Coarse boards as stated in 2.

The following list contains most of the CDC part numbers associated with the I/O boards, the Control Mux boards, and the Servo Coarse boards used by Wang Labs.

I/O Board 726-5778

- \* 75891850 series code 2 (unique to Wang)
- \* 77616751 series code 2/3 (unique to Wang)
- 77616770A
- 77616790
- 77622500-1 series code 3 (universal)

I/O Board 726-6669

- \*\* 77665650 series code 4 (universal)

OVER

GROUP: VS On-Line Support

MAIL STOP: 001-260

COMPANY CONFIDENTIAL

WANG Laboratories, Inc.



TECHNICAL SERVICE BULLETIN  
SECTION: HardWare Technical

NUMBER: HWT 7087 REPLACES: HWT 7021 DATE: 05/05/87 PAGE 2 OF 2  
MATRIX ID. 3105 PRODUCT/RELEASE# PHOENIX  
TITLE: Phoenix board compatibility

Control Mux 726-5779  
77616600  
77624700

Control Mux 726-6668  
\*\* 77666950

Servo Coarse 726-5780  
\* 75885600  
77622400/01/02/03  
77622420  
77622750  
77666800/01

Servo Coarse 726-6887  
\*\* 77682950 has jumpers J1 (top rt) & J2  
(between U22 and U27)  
set J1 in (loss of AGC recoverable  
without power down)  
set J2 out (120 sec purge)  
in (90 sec purge)

NOTE: THE NEWER REV BOARDS ARE VERY SIMILAR TO THE OLDER VERSION BOARDS. BOARDS IN STOCK COULD BE MIXED. IF A PARTICULAR REV BOARD IS NEEDED, VERIFY THE REV WHEN TAKEN FROM STOCK. WHEN ORDERING BOARDS- SPECIFY THE CDC NUMBER AND VERIFY CORRECT UPON RECEIPT.

ADDITIONAL INFORMATION:

There are 3 different Relay Boards for the Phoenix. Two of the boards are for Blockpoint 4 drives (pluggable terminal strip). If replacing a Relay Board in a Blockpoint 4 drive, the same type Relay Board should be used as identified by the CDC part number on the board. Do not replace one type with another.

Blockpoint 3 Relay Board  
726-5786 CDC # 75898850/77634490

Blockpoint 4 Relay Boards  
726-6724 CDC # 77680650 No AIR  
726-6724A CDC # 77713900 LO AIR OPTION

GROUP: VS On Line Support MAIL STOP: 001-260

COMPANY CONFIDENTIAL

WANG Laboratories, Inc.



# CDC Disk Cartridge Product Specification Manual for

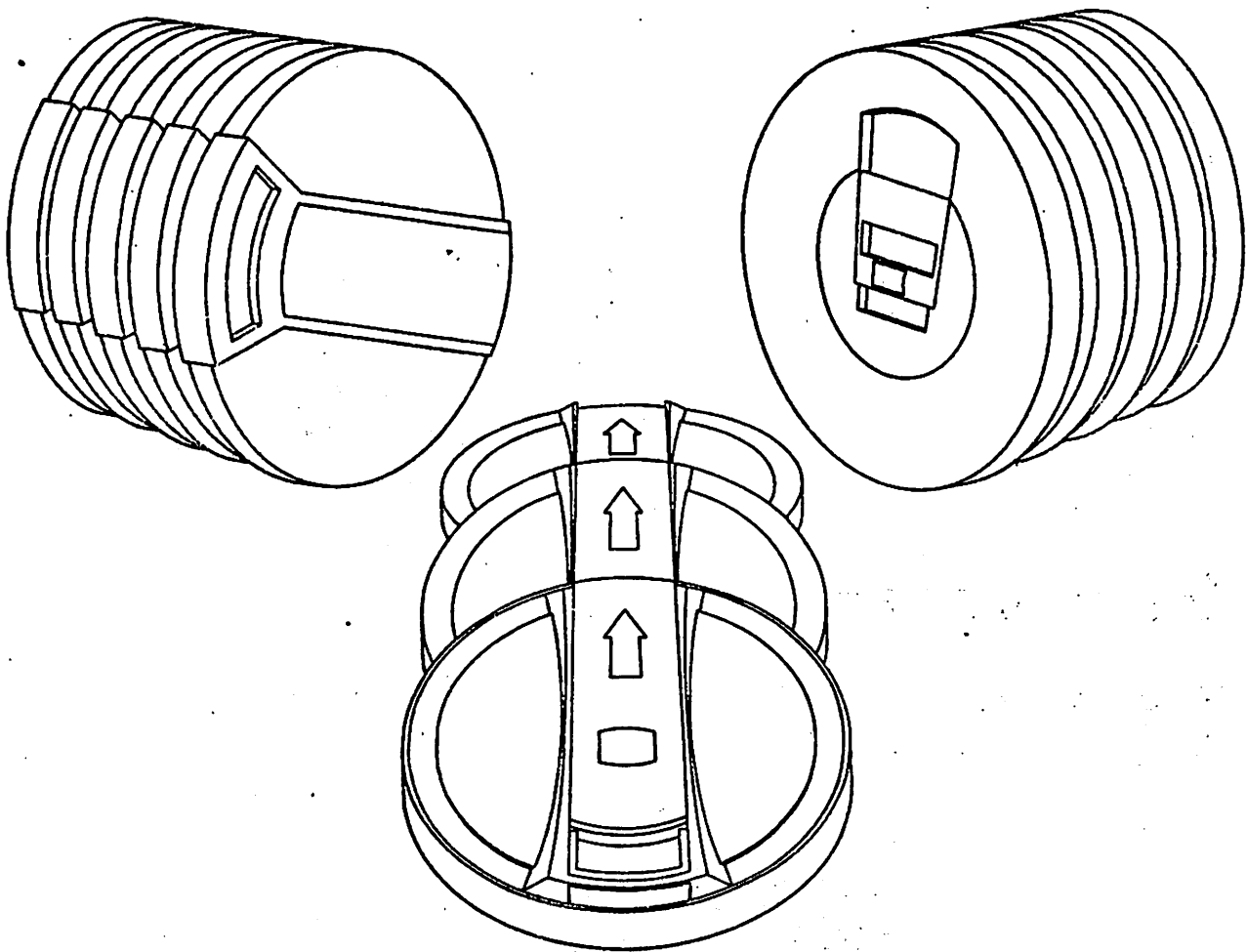

Model No. 1204/91204

Manual No. 76204375

## PREFACE

This manual describes the physical dimensions of the media which are necessary for interface with the drives. Signal characteristic requirements and other media requirements necessary for reliable operation with the drives have also been defined in this manual.

MANUAL REVISION     A     DATE 7/26/78

This revision makes all previous revisions of this manual (manuals having the same model number and manual number on the cover sheet) obsolete. This revision should be reviewed in its entirety. The information in this manual is current as of the date of the revision, but is subject to future change by CDC without notice.

Contents in this manual may cover items which have been patented or have a patent pending, and the distribution of this manual, under no circumstances, constitutes or implies a grant of a license.

# PRODUCT SPECIFICATION

MEMORY PRODUCTS ENGINEERING DIVISION

## TABLE OF CONTENTS

1.0	SCOPE.....	3
2.0	APPLICABLE DOCUMENTS.....	3
3.0	REQUIREMENTS.....	3
3.1	GENERAL.....	3
3.2	CARTRIDGE MECHANICAL CHARACTERISTICS.....	3
3.2.1	Components.....	3
3.2.2	Housing.....	3
3.2.3	Cartridge Hub.....	4
3.2.4	Weight.....	4
3.2.5	Balance.....	4
3.2.6	Hub Holding Force.....	4
3.2.7	Cartridge Operating Speed.....	4
3.2.8	Misregistration.....	4
3.3	INDIVIDUAL DISK PHYSICAL CHARACTERISTICS.....	10
3.3.1	Dimensions.....	10
3.3.2	Material.....	10
3.3.3	Magnetic Characteristics.....	10
3.3.4	Dynamic Surface Characteristics.....	10
3.3.5	Surface Roughness.....	10
3.3.6	Head Gliding Requirements.....	11
3.3.7	Recording Surface Durability.....	11
3.4	DATA SURFACE RECORDING CHARACTERISTICS & TRACK FORMAT.....	11
3.4.1	General.....	11
3.4.2	Capacity.....	11
3.4.3	Read Errors.....	11
3.4.4	Data Surface Format & Initialization Rqmts.....	12
3.5	SERVO SURFACE PRE-RECORDED TRACKS.....	15
3.5.1	General.....	15
3.5.2	Definitions.....	15
3.5.3	Servo Surface Track Location & Characteristics.....	16
3.6	CARTRIDGE ENVIRONMENTAL REQUIREMENTS.....	17
3.6.1	Temperature Range.....	17
3.6.2	Relative Humidity.....	17
3.6.3	Wet Bulb Reading.....	17
3.6.4	Altitude.....	18
3.6.5	Shock.....	18
3.6.6	Vibration.....	18
3.6.7	Cleaning.....	18
3.6.8	Rework.....	18

# PRODUCT SPECIFICATION

MEMORY PRODUCTS ENGINEERING DIVISION

## TABLE OF CONTENTS (Continued)

### FIGURES

1	CARTRIDGE ASSEMBLY.....	5
2	TOP VIEW.....	6
3	HOUSING.....	7
4	HUB AND DISK ASSEMBLY.....	8
5	CARTRIDGE WITH REMOVABLE COVER.....	9
6	CARTRIDGE IN DRIVE.....	9
7	SPINDLE.....	9
8	INITIALIZED DATA TRACK FORMAT.....	13
9	TYPICAL DIBIT CONFIGURATION.....	14

# PRODUCT SPECIFICATION

MEMORY PRODUCTS ENGINEERING DIVISION

## 1.0 SCOPE

This specification describes the characteristics and usage of the CONTROL DATA® Preformatted 1204 (91204) Disk Cartridge, P/N 76204000 (76204001). This disk cartridge is used on the Control Data 9448 series front-loading Cartridge Module Drive (CMD)...

## 2.0 APPLICABLE DOCUMENTS

PUBL. 76888221 - 9448 Product Specification 3600 RPM

## 3.0 REQUIREMENTS

### 3.1 General

The CONTROL DATA 1204 Disk Cartridge is a removable, high density, single disk data storage cartridge designed for use with the CONTROL DATA 9448 Drive. When removed from the drive, the cartridge is protected from contamination by a removable bottom cover. The cartridge consists of an oxide-coated disk clamped to a magnetic hub and encased in a plastic housing. The lower surface of the disk is used for data storage and the upper surface for servo positioning and Index/timing. Pre-recorded data includes servo surface positioning data and pre-Initialized data surface with alternate track assignments.

### 3.2 Cartridge Mechanical Characteristics

#### 3.2.1 Components

The disk cartridge consists of the following components (See Fig. 1 ):

1. Top Cover Assembly
2. Hub
3. Recording Disk
4. Clamp Ring
5. Fixed Bottom Cover
6. Removable Cover

#### 3.2.2 Housing

When the cartridge is not in use, the disk is enclosed by a housing (top cover assembly and fixed bottom cover) and the removable cover. A latch releases the removable cover so the cartridge can be lifted out before insertion into the drive. Pins and shoulder stops in the top cover assembly engage a mating feature in the drive that locates guides and supports the cartridge as it is inserted and removed from the drive. The cartridge is designed for a minimum of 10,000 insertion, removal cycles. A recess and handle in the top cover are provided to aid in handling the cartridge. The top and removable covers are designed to interlock and allow cartridge stacking. When not in the

# PRODUCT SPECIFICATION

MEMORY PRODUCTS ENGINEERING DIVISION

### 3.2.2 (Continued)

- drive, the cartridge is protected by attaching the removable cover.
- The disk and hub are constrained to prevent disk contact with the interior of the housing during all phases of normal handling.
- Housing dimensions are given in Figures 2 & 3.

### 3.2.3 Cartridge Hub

The critical dimensions and relationship of the recording disk and hub are shown in Fig. 4.

### 3.2.4 Weight

The weight of the cartridge without the removable cover is 4.5 lbs. (2,04 Kg).

### 3.2.5 Balance

Rotating components are balanced within 4 in.-gm. in a single plane parallel to the armature plate and .311 (7.90) above the bottom surface of the armature plate.

### 3.2.6 Hub Holding Force

The drive spindle magnetic chuck exerts a gross force of  $35 \pm 5$  lbs. ( $156 \pm 22$ N) which provides attraction for the hub armature plate.

### 3.2.7 Cartridge Operating Speed

- The cartridge is designed to operate at 3600 RPM, +2.5% -3.5%.
- The hub-disk assembly rotates in a counterclockwise direction when viewed from above.

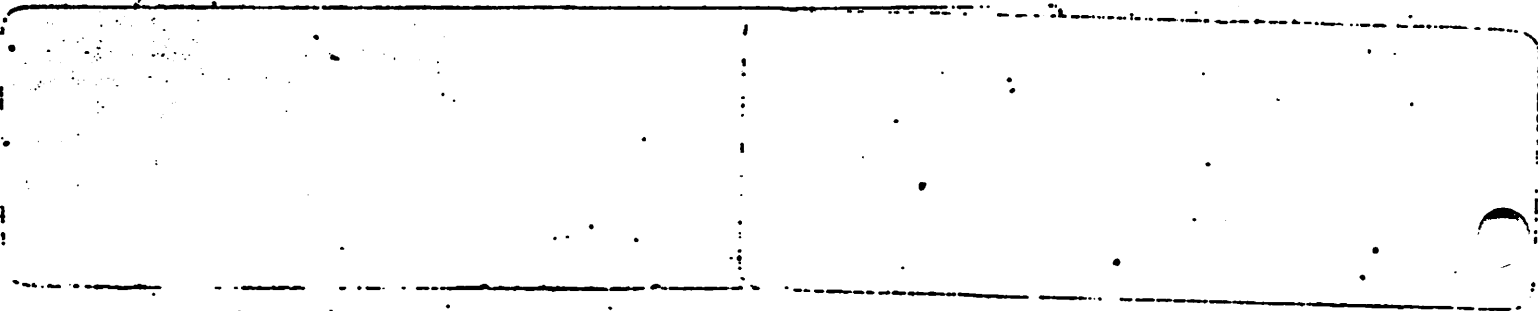

# ENGINEERING SPECIFICATION

MEMORY PRODUCTS ENGINEERING DIVISION

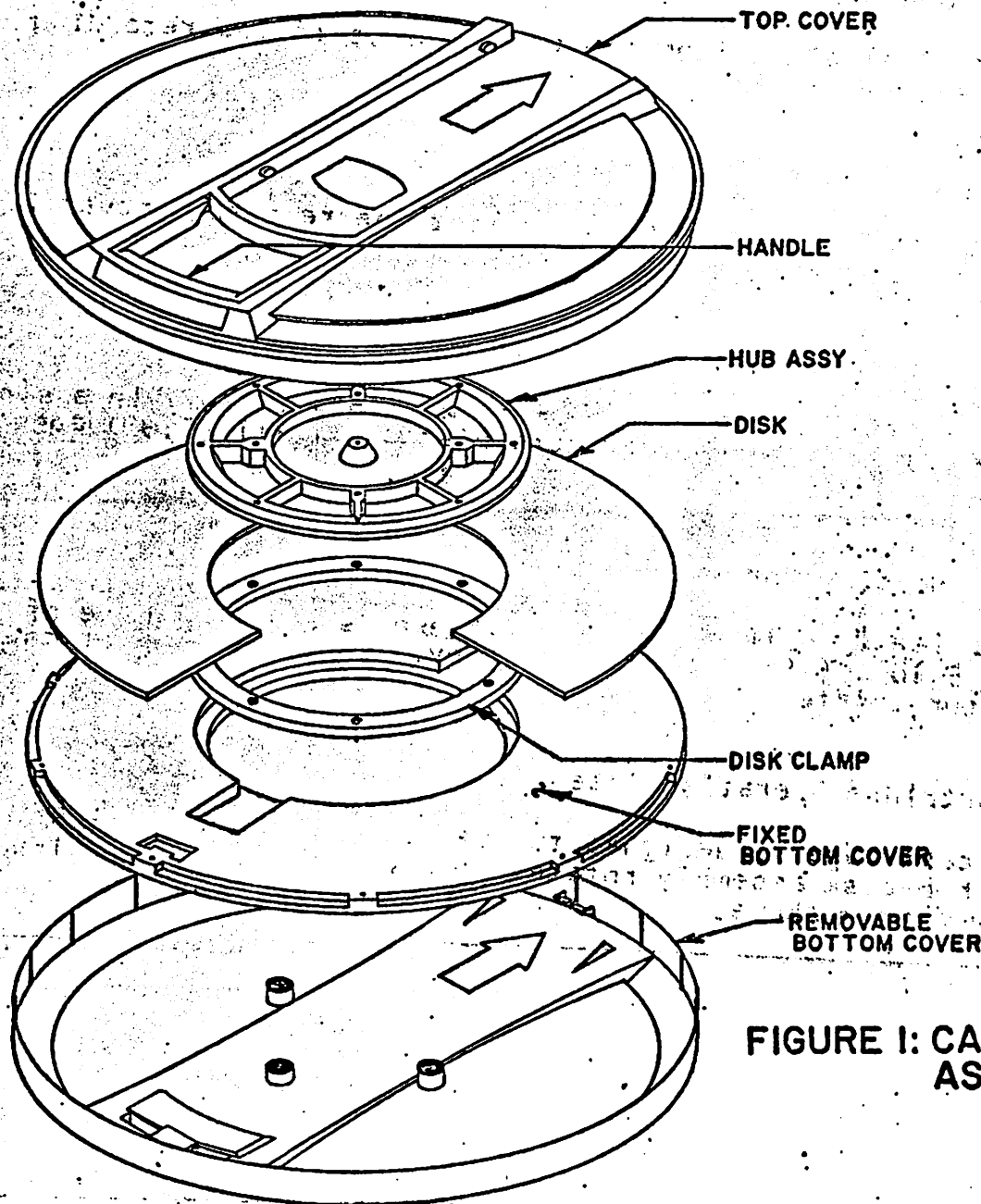

**FIGURE 1: CARTRIDGE ASSEMBLY**

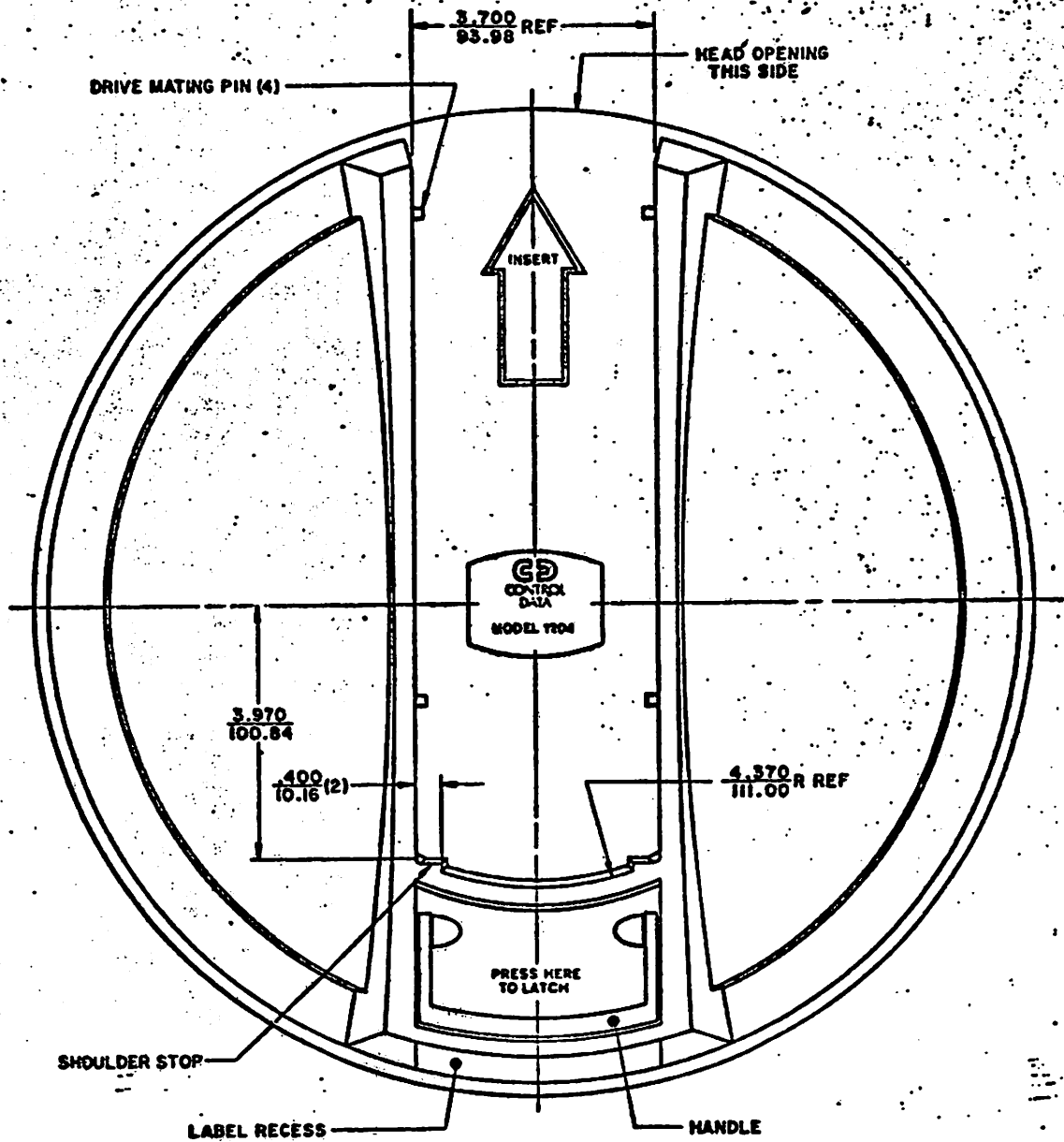

FIGURE 2: TOP VIEW.



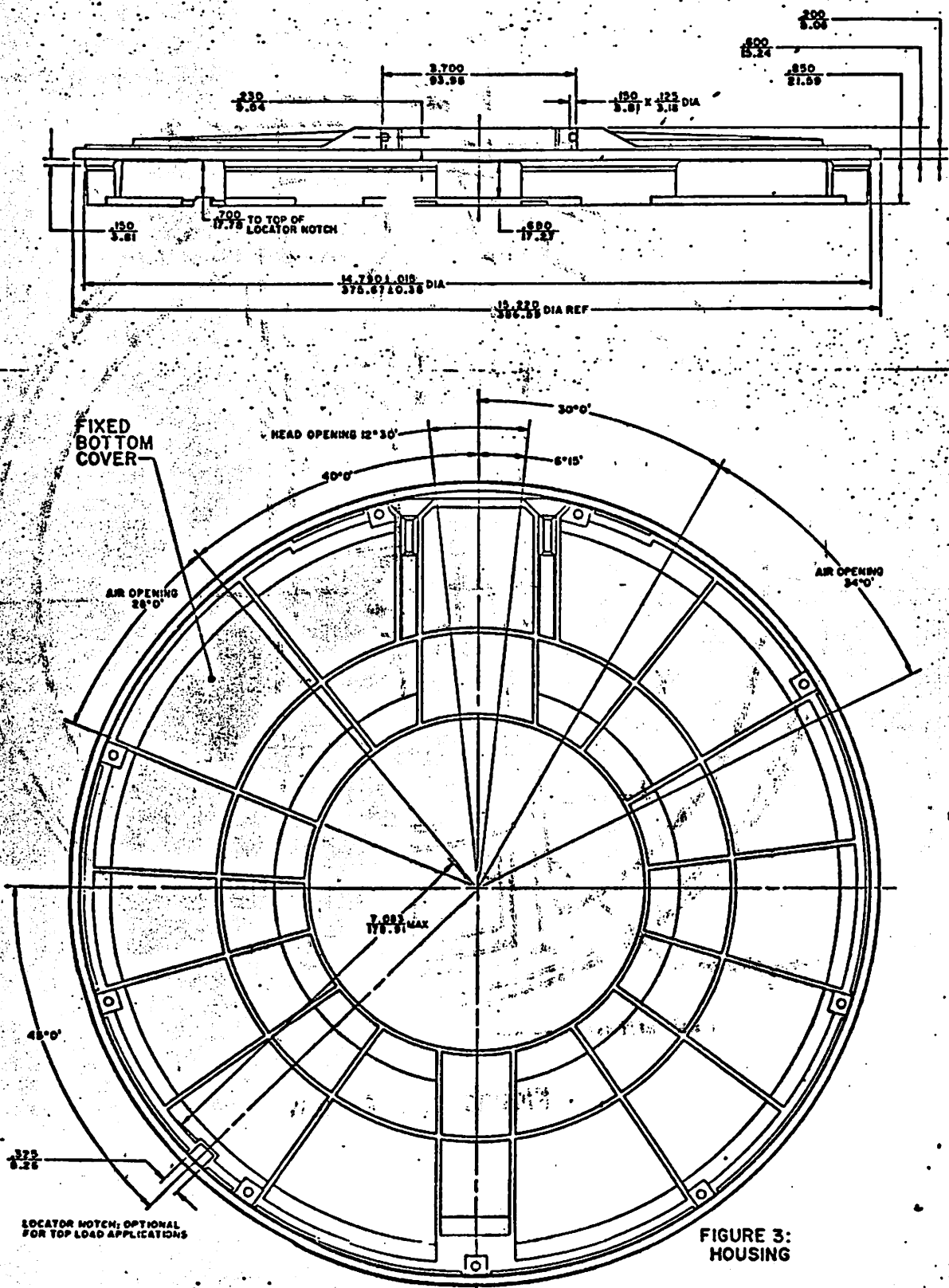
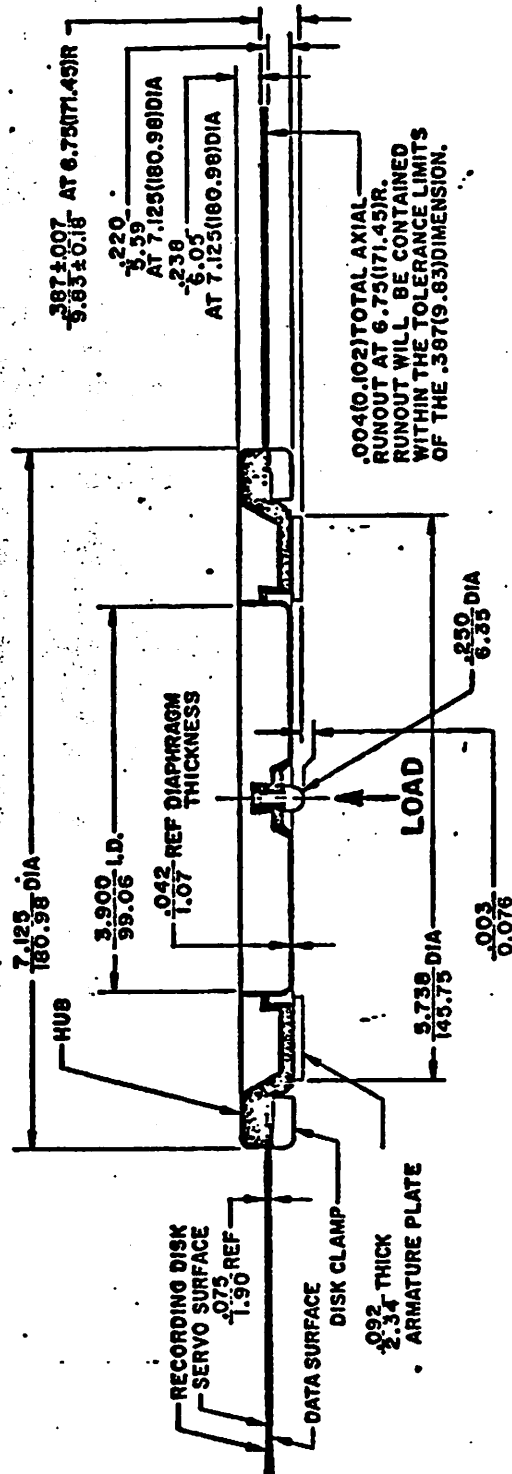
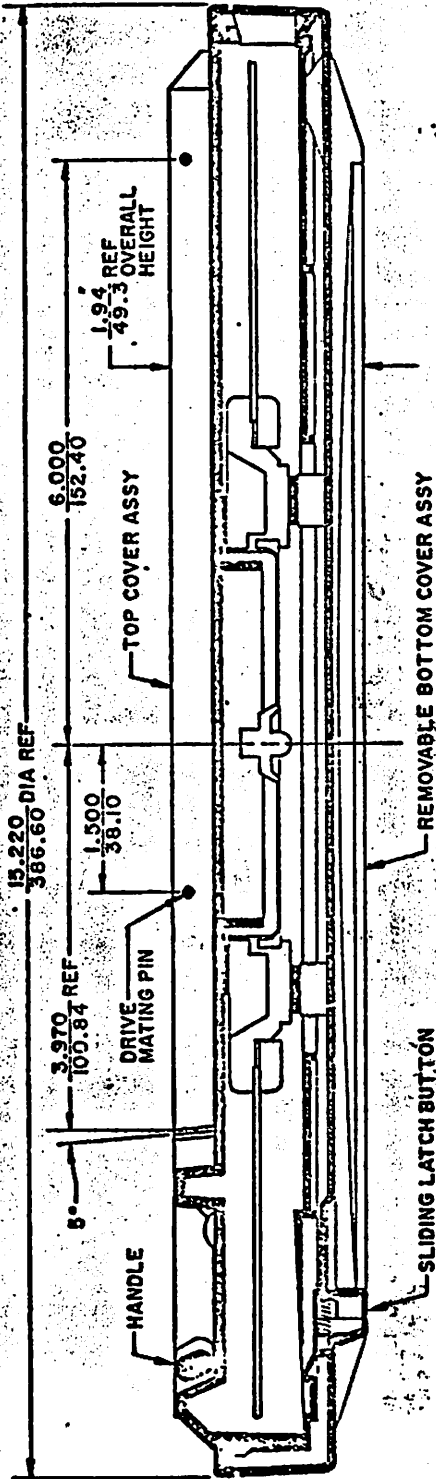

FIGURE 3:  
HOUSING



THIS DIMENSION SHALL BE SATISFIED WITH A CENTRALLY APPLIED LOAD OF 8.5 TO 20.5 POUNDS (3.86 TO 9.31 KILOGRAMS) AS SHOWN. IN THE ABSENCE OF A LOAD, DIMENSION SHALL BE .012 (0.30).

FIGURE 4: HUB & DISK ASSEMBLY.



**FIGURE 5: CARTRIDGE WITH REMOVABLE COVER.**

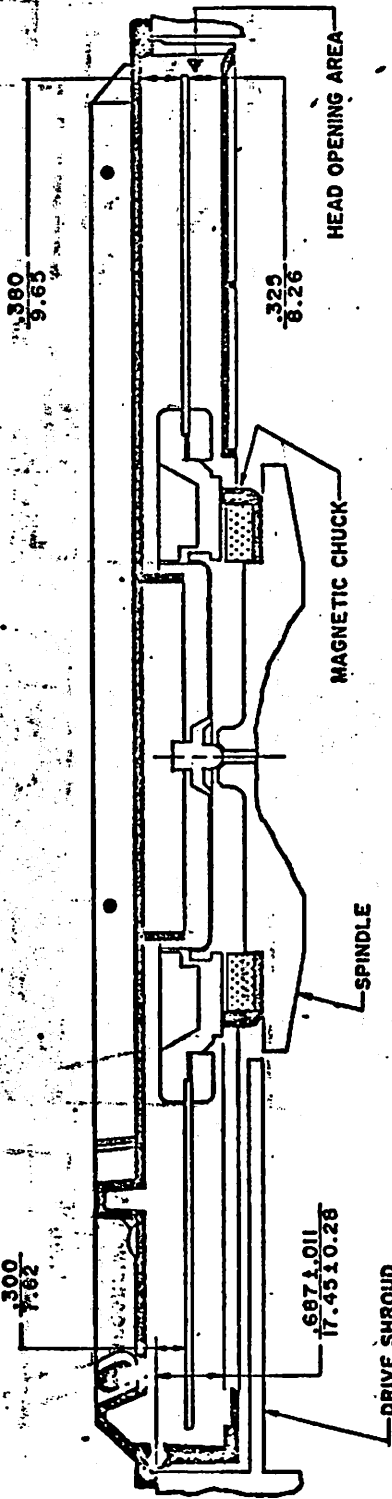

**FIGURE 6: CARTRIDGE IN DRIVE.**

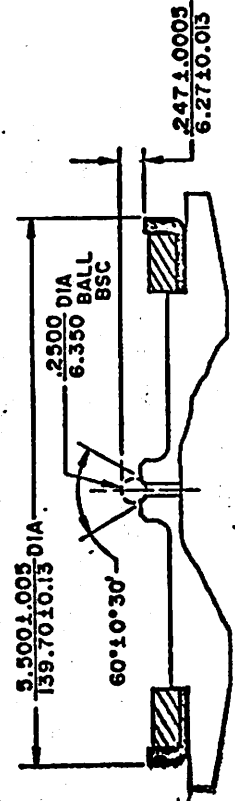

**FIGURE 7: DRIVE SPINDLE**

### 3.3 Individual Disk Physical Characteristics

#### 3.3.1 Dimensions (Nominal)

The recording disk has an outside diameter of 14.025 (356.24). Disk thickness is .075 (1.905).

#### 3.3.2 Material

The material and construction of the disk cartridge is such that the dimensional, inertial, balance and other functional operating requirements are met. Each disk is composed of a base material of aluminum coated with a layer of ferromagnetic material dispersed in an organic binder.

#### 3.3.3 Magnetic Characteristics

The oxide used in the magnetic recording surface has the following magnetic characteristics when measured circumferentially in a field of 1000 oersteds.

Coercivity (Hc)	300 Oersteds
Saturation (Bm)	3200 Gauss
Residual Saturation (Br)	1700 Gauss

#### 3.3.4 Dynamic Disk Surface Characteristics

The axial disk runout does not exceed .004 (.102) TIR when measured at the 6.75 (171.45) radius.

#### 3.3.5 Disk Surface Roughness

The finished magnetic coating surface is less than 2.0  $\mu$ in. (arithmetic average) when measured with a 0.0001 in. radius stylus over a 0.030 in. cutoff range with a stylus speed of 0.01 in./sec. and a weight of 100 mg.



# PRODUCT SPECIFICATION

MEMORY PRODUCTS-ENGINEERING DIVISION

## 3.3.6 Head Gliding Requirements

Each disk surface is burnished with a burnishing head to ensure that, when the disk is installed on a CONTROL DATA 9448 Drive, the recording surfaces are free of surface irregularities or protrusions that could cause head-to-disk interference if the heads are flown at a minimum spacing of 20  $\mu$ in.

## 3.3.7 Recording Surface Durability

The magnetic coating is compatible with CONTROL DATA read/write heads used in the 9448 Drive operated within the specified environments. The coating will not chip, peel or adversely affect the read/write heads as a result of normal operation and will withstand 50,000 head loadings.

## 3.4 Data Surface Recording Characteristics and Track Format

### 3.4.1 General

The CDC 1204 cartridge is designed to operate with a recorded track density of 384 tracks/in. Tracks are referenced to the servo surface and to the 1204-51 Control Data CE Cartridge (P/N 76204400). The maximum bit density is 6038 bits/in., and the nominal data bit rate is 9.677 megabits/sec. To assure pack interchangeability, the oxide coating characteristics are designed for saturation mode recording when used with the CDC 9448 drive.

### 3.4.2 Capacity

The recording surface on the cartridge can contain up to 808 primary data tracks. There are also 15 alternate tracks available on the surface to be used as an alternate for any primary track that is defective. The primary tracks are located in cylinders 0 through 807 and the alternate tracks in cylinders 808 through 822. Each track is addressed by a cylinder and head number which is pre-recorded in the home address area of the track.

### 3.4.3 Read Errors

#### 3.4.3.1 Definition

Read errors normally occur if a bit is absent (reduced in amplitude) or shifted significantly from its nominal position. The cartridge is designed to operate with systems having error correction capabilities of up to eleven bits of errors within one burst location providing the rest of the track is error free. Therefore, a data track containing one or more errors within eleven bits is considered

**3.4.3.1 (Continued)**

a correctable error track. A track which contains errors that exceed 11 bits is considered an uncorrectable error track.

**3.4.3.2 Read Error Acceptance Criteria**

No read errors of any type at cylinders 000 & 822, Hd 00 (Data Surface).

Not more than 6 correctable error tracks per cartridge.

No uncorrectable error tracks per cartridge.

**3.4.4 Data Surface Format and Initialization Requirements****3.4.4.1 General Format Requirements**

All data tracks are formatted with Home Address (HA) and Record Zero (R0). Format data for each track starts at Index which is derived from the servo surface signal. The basic recording unit is the eight-bit hexadecimal byte which corresponds to 0.83 usec. Figure 3 shows the sequential pre-recorded format required of every data track in a disk cartridge.

**3.4.4.2 Pre-Initialization Requirements**

Each data track is analyzed for correctable and uncorrectable error conditions. If no uncorrectable error conditions are detected, the track is considered flag free and the Home Address and Record Zero are written. The flag byte of the Home Address is equal to 00 and Record Zero contains an eight-byte data field of all zeros. If an uncorrectable error condition is detected after usage, the track is considered defective and an alternate track can be assigned. Defective tracks are also written with Home Address and an eight-byte Record Zero; however, the flag byte of the Home Address contains 02 and the count field of Record Zero contains the address of the alternate track assigned. The first alternate track assigned is cylinder 808, head 00. Assigned alternate tracks must also be flag free. If the alternate is flag free, the Home Address and Record Zero are written with the flag byte of the Home Address equal to 01 and the count field of the Record Zero containing the address of the defective track. If after usage, the alternate track is not flag free, the Home Address must contain 03 and the count field of Record Zero assigns the track to itself. Flag format and typical initialization data is shown in Figure 7.

# PRODUCT SPECIFICATION

MEMORY PRODUCTS ENGINEERING DIVISION

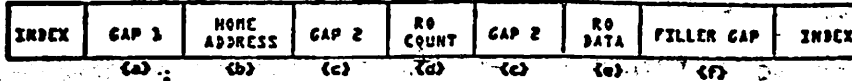

(a) GAP 1



(b) WORD ADDRESS



(c) GAP 2



(d) RO COUNT



(e) RO DATA



(f) FILLER GAP



**NOTES:**

1. SINGLE QUOTATION MARKS INDICATE HEXADECIMAL EXPRESSIONS.
2. PA = PHYSICAL ADDRESS (EXPRESSED IN HEXADECIMAL)  
 FIRST BYTE = LOW ORDER CYLINDER ADDRESS  
 SECOND BYTE - BIT 0 = HIGH ORDER CYLINDER ADDRESS, 512  
 BIT 1 = HIGH ORDER CYLINDER ADDRESS, 256  
 BIT 2 TO 4 = 0  
 BIT 5 TO 7 = 000 HEAD ADDRESS 0

**3. FLAG FORMAT**

- BIT 0-5 = 0
- BIT 6 = 0 IF TRACK IS NORMAL
- BIT 6 = 1 IF TRACK CONTAINS A NON-CORRECTABLE ERROR
- BIT 7 = 0 IF TRACK IS NORMAL
- BIT 7 = 1 IF TRACK IS ASSIGNED AS AN ALTERNATE TRACK

**RO COUNT FIELD FORMAT**

TRACK	FLAG BITS	CCHH
CYL 000-807 (NO DEFECTS)	BIT 6: 0 BIT 7: 0	0 - - - - - SEEK ADDRESS
CYL 808-822 (UNASSIGNED, ALTERNATE NO DEFECTS)	BIT 6: 0 BIT 7: 0	0 - - - - - SEEK ADDRESS
CYL 000-807 (DEFECTIVE)	BIT 6: 1 BIT 7: 0	- - - - - ALTERNATE TRACK ADDRESS IN RO COUNT FIELD
CYL 808-822 (ASSIGNED ALTERNATES)	BIT 6: 0 BIT 7: 1	- - - - - DEFECTIVE TRACK ADDRESS IN RO COUNT FIELD
CYL 808-822 (DEFECTIVE)	BIT 6: 1 BIT 7: 1	- - - - - SEEK ADDRESS

4. CCHH = TWO BYTES OF CYLINDER ADDRESS AND TWO BYTES OF HEAD ADDRESS AS FOLLOWS:

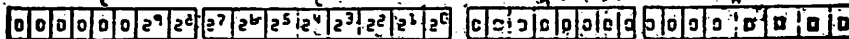

NOTE: ADDRESS CCHH INFORMATION MUST EQUAL PHYSICAL ADDRESS INFORMATION. REFER TO NOTE 3 FOR CCHH IN THE RO FIELD.

5. ECC = A SEVEN BYTE ERROR CORRECTION CODE WHICH ENABLES DETECTION AND CORRECTION OF ERRORS IN THE DATA READ FROM THE DISK. THE ECC IS A HARDWARE GENERATED 56 BIT CYCLE ERROR CHECKING CODE WITH A DIVIDE POLYNOMIAL OF:  

$$x^{56} + x^{55} + x^{49} + x^{45} + x^{41} + x^{37} + x^{36} + x^{37} + x^{36} + x^{33} + x^{22}$$

$$+ x^{19} + x^{17} + x^{16} + x^{15} + x^{14} + x^{12} + x^{11} + x^7 + x^5 + x^1 + 1.$$
6. THE SYNC BYTES ARE USED TO INDICATE THE START OF DATA.

**D81C**

FIGURE 8. INITIALIZED DATA TRACK FORMAT

# PRODUCT SPECIFICATION

MEMORY PRODUCTS ENGINEERING DIVISION

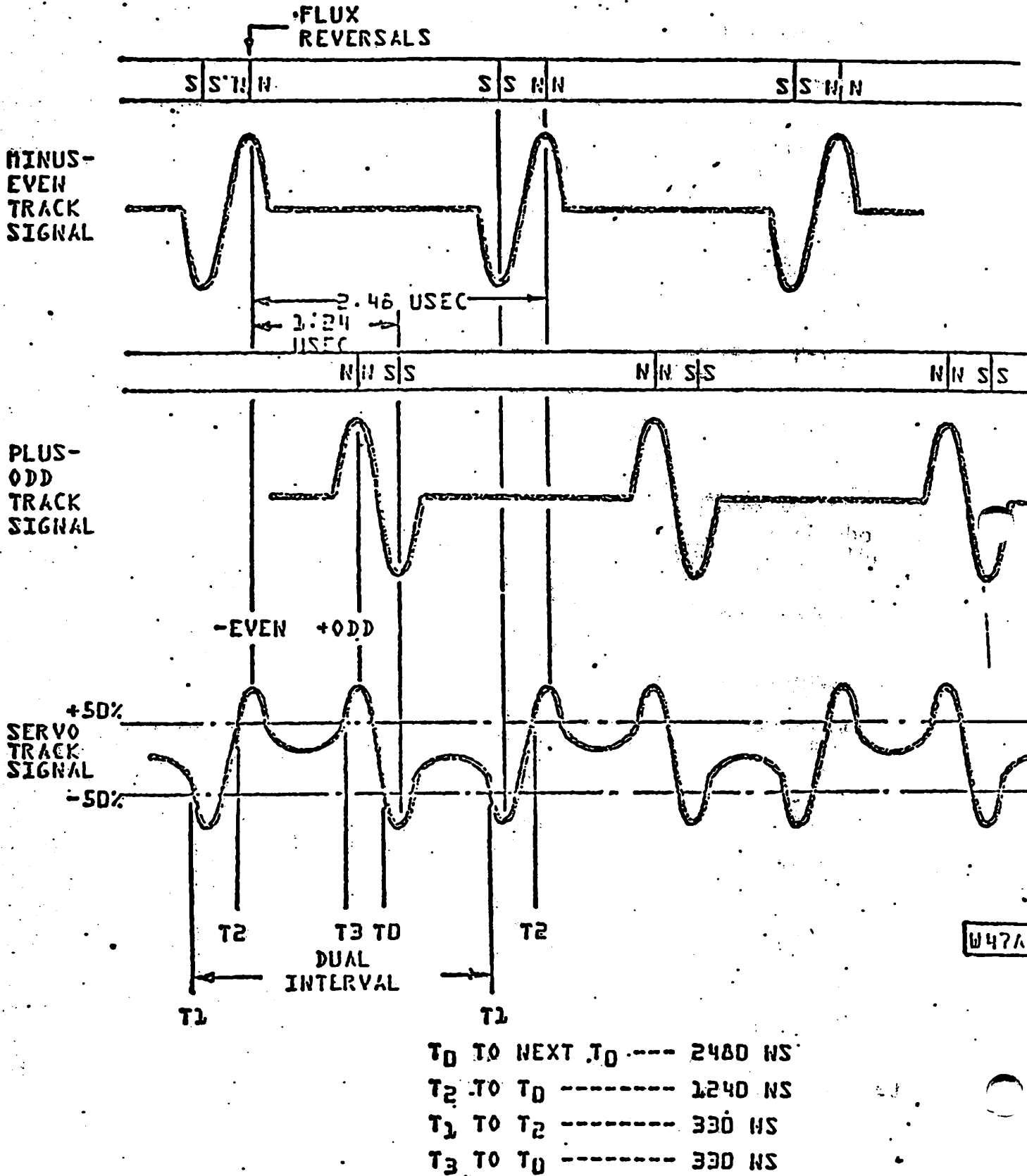

FIGURE 9. TYPICAL DIBIT CONFIGURATION



## 3.5 Servo Surface Pre-Recorded Tracks

### 3.5.1 General

The upper surface of the disk cartridge is pre-recorded with servo positioning data and is used as an electrical and physical reference for the data (lower) surface when the cartridge is used on a CDC 9448 Drive. Ref. Figure 4.

### 3.5.2 Definitions

#### 3.5.2.1 Dibit

A dibit is the readback signal produced from a magnetic head that has a magnetic surface with two closely spaced saturation flux reversals passed under it. A typical dibit configuration is shown in Figure 9.

#### 3.5.2.2 Plus-Odd Track

A plus-odd track is a magnetic surface which produces dibits with the leading pulse positive and the trailing pulse negative when read by a correctly polarized servo head. The dibit must occur at an odd numbered interval.

#### 3.5.2.3 Minus-Even Track

A minus-even track is a magnetic surface which produces dibits with the leading pulse negative and the trailing pulse positive when read with a correctly polarized servo head. The dibit must occur at an even numbered interval.

#### 3.5.2.4 Interval

An interval is the time between leading peaks of successive minus-even and plus-odd dibits when read on a servo track. This is nominally equal to 1.24 usec.

#### 3.5.2.5 Dual Interval

A dual interval is the combined time between the beginning of an odd interval and the end of an even interval as shown in Figure 9.

**3.5.2.6 Track Center**

The head position for which the read signal contains equal amplitudes of plus-odd and minus-even signal components derived from two adjacent tracks, necessitating concentric tracks to be recorded without areas void of magnetic transitions. Equal amplitude refers to the leading peak of a dibit, and is nominally the condition with the head centered between plus-odd and minus-even track centers. This is further referred to as servo track center.

**3.5.3 Servo Surface Track Location and Characteristics****3.5.3.1 Track Locations and Spacing**

All servo positioning tracks are referenced to Track 404 of the CE cartridges and have a nominal track-to-track spacing of 0.0026 in. measured radially from cartridge center. The actual magnetic center of Track 404 with the disk cartridge at 68°F (20°C) is located along a line whose (nominal) coordinates with respect to spindle center are  $X = 5.3307$ ,  $Y = .000$  inches.

**3.5.3.2****Servo Zone**

A servo track consists of a combination of plus-odd and minus-even tracks. The track electrical center is precisely located when the read head signal contains equal amplitudes of plus-odd and minus-even signal components. The servo zone thus consists of 823 servo tracks created by writing 824 tracks alternating between plus-odd and minus-even, from track -0.5 through 822.5 respectively. There are also guard bands located on either side of the servo zone which consists of 24 plus-odd tracks recorded at track -24.5 through -1.5 and 36 minus-even tracks recorded at Track 823.5 through 858.5. There must also be a non-recorded area of the disk used as a head loading zone located between the outer guard band and a radius of 6.675 inches.

**3.5.3.3 Dibit Timing**

As read by a read head, each track is divided into 13,440 equal intervals; and when rotating counterclockwise at 3600 rpm, the tracks have the dibit timing relationships as shown in Figure 9.



# PRODUCT SPECIFICATION

MEMORY PRODUCTS ENGINEERING DIVISION

### 3.5.3.4 Missing Dibits

The servo track, as read by a servo positioning transducer, has no consecutive dual interval missing dibits and has no more than four non-consecutive dual intervals with missing dibits. (A dibit is considered missing when the pulse amplitude is less than prescribed percentage of the agc/reference amplitude as derived on a CONTROL DATA 9448 Drive.)

### 3.5.3.5 Servo Track Eccentricity

Servo track eccentricity does not exceed 150 uin. maximum TIR with the pack installed at any angular position on the spindle, when checked on a spindle with less than 20 uin. TIR.

### 3.5.3.6 Index Pattern

Each servo track has one index pattern encoded on it. An index pattern consists of a 111110101101 pattern of dibits on both plus-odd and minus-even tracks. The order of occurrence of the missing dibits must be left-to-right; each zero represents a dual interval which has no dibits written in it.

## 3.6 Cartridge Environmental Requirements

### 3.6.1 Temperature Range

Operating: +50°F (+10°C) to +135°F (57°C)

Maximum rate of temperature change shall not exceed 0.2°F (0.1°C) per minute.

Non-operating (Storage & Transit): -30°F (-35°C) to +150°F (+65°C)

Maximum rate of temperature change shall not exceed 20°F (11°C) per hour.

### 3.6.2 Relative Humidity

Operating and nonoperating: 8 to 80% RH.

### 3.6.3 Wet Bulb Reading

Operating: 78°F Maximum

Storage conditions in shipping carton: 85°F maximum.

# PRODUCT SPECIFICATION

MEMORY PRODUCTS ENGINEERING DIVISION

## 3.6.4 Altitude

**Operating:** Mean sea level to 10,000 ft.

**Nonoperating:** Mean sea level to 40,000 ft. above sea level or a simulated equivalent.

## 3.6.5 Shock

**Nonoperating:** The cartridge will not suffer damage or fail to perform as specified herein when subjected to 18 impact shocks of 5 (+0.5) g, consisting of 3 shocks in opposite directions along each of 3 mutually perpendicular axes. Each shock impulse will have a time duration of 11 ( $\pm 1$ ) ms. The maximum "g" will occur at approximately 5½ ms.

## 3.6.6 Vibration

**Nonoperating:** The cartridge with removable cover latched in place will withstand a peak displacement of  $\pm 0.005$  in. in the frequency of 5 to 60 Hz and  $\pm 2$  g in the range of 60 to 500 Hz.

## 3.6.7 Cleaning

Cartridge cleaning is to be performed only in a manner as described in the applicable 9448 maintenance manual.

## 3.6.8 Rework

If during normal use, data areas of the pack become defective, the user may flag these defective areas and assign alternate tracks by the use of one of several available utility programs. If the factory pre-recorded servo positioning tracks of the disk specified in this document are destroyed, they cannot be regenerated by field personnel and must be reworked at the plant of manufacture.

MASTER

PHOENIX ALIGNMENT

1. PURGE UNIT and ALIGNMENT PACK (up to speed, servo disconnected)
  
2. CABLING (Disk and FTU off)
  - A. Install alignment extender brd in drive, slot 4, and alignment board into extender
  - B. Install 2 wire cable from Servo Fine (white to front) to R/W Preamp (white on top)
  - C. Install 8 wire cable from Servo Fine (Arrow points up and towards wire) to Alignment Extender Brd (Arrow points to rear of drive away from wire)
  - D. Install 3 ribbon cables between FTU and Drive.
    - Small cable from J1 of Brd 2 in FTU (red wire to right) to I/O Brd (red wire on top) bottom of A connector via adapter cable.
    - Medium cable from J3 of Brd 2 in FTU (red wire to right) to CONTROL/MUX Brd, B connector (red wire on top)
    - Large cable from J2 of Brd 2 in FTU (red wire to right) to I/O Brd (red wire on top) top of A connector via adapter cable.
  
3. SWITCH SETTINGS (Setting up for removable servo alignment)
  - A. Alignment extender board: S1 to FXD (Load off fixed servo)
  - B. Alignment Board: S1 to N (negative polarity of alignment voltage)  
 S2 to RW (always RW with Phoenix)  
 S3 to X1 (Attenuation factor of alignment voltage)
  - C. Servo Fine: S1 to S (looking at servo head) ALWAYS LOOKING AT REMOVABLE SERVO. To ALIGN FIXED SERVO To REMOVABLE, SWAP CONNECTIONS ON SERVO PREAMP FOR SERVO HEADS.
  - D. FTU: Data Entry to Device Type; R/W Select to Alignment; Access Select To Direct Seek

HEAD and RECORD to manual, START and RUN off  
 STEP-down; SINGLE/CONT.-cont; -+ to center; LATE/EARLY-center  
 WRITE FLAG-off; WRITE PROTECT-on; AM/SECTOR-sector; EOT STOP-off  
 ERROR OVERRIDES-off; SHIFT PATT/DATA PATT-data patt; SEQ PWR-off

4. INITIAL POWER ON

- A. Power on FTU
- B. Pull out card cage, loosen removable heads to 4 lb/(if fixed servo has been loosened, it should be centered and tightened to 12 lb/)
- C. Power on drive to LOAD (Alignment pack previously installed and purged)
- D. FTU-START and RUN switches to ON(3rd row down, 7 right most lites come on)
- E. FTU-key in 8905 (90 Meg), 8903 (60 Meg), 8901 (30 Meg)  
Key LOAD then SEL DRIVE (Busy light will flash till drive ready) set DATA Entry switch to destination
- F. Bring Drive to READY (Busy light stops blinking on FTU)

5. SCOPE and METER SET UP

- A. Scope: Ch 1- 50 mV/div to READ SIGNAL on Alignment Board  
Ground to chassis  
Sync on Ch 1, 1 microsec/div
- B. Volt Meter: 500 milV scale  
Positive lead to + TP. of Align Brd., Neg lead to - TP of Align Brd.

**CAUTION: WHEN TIGHTENING OR LOOSENING HEADS IT'S A GOOD IDEA TO HAVE HEADS UNLOADED"**

6. ALIGNMENT of REMOVABLE SERVO to FIXED SERVO

- A. Key RTZ on FTU (heads should move slightly)
- B. Move R Servo Head to the outer guard band and back to track 0 using scope (first balanced dibit pattern) heads previously loosened to 4 lb/ (See diagram on next page)
- C. Key in CLR, 0404, LOAD, GO
- D. Rough Adj-Adjust head till dibit pattern on scope is balanced.
- E. Fine Adj-fine adjust head for meter reading as close to 0 Mil V as possible.
- F. Calculate offset-record meter reading, switch S1 of Align Brd. to P. Record reading, subtract readings, should be less than 50 MilV (if off, loosen, Fine Adj again)

EXAMPLE:

P reading (+25 milV)-N reading (+5 milV)=20 milV offset  
P reading (+25 milV)-N reading (-10 milV)=35 milV offset  
P reading (-5 milV)-N reading (-10 mil V)= 5 milV offset

- G. Tighten down head to 12 lb/ making sure meter reading is less than +/- 50 milV while guiding carriage with other hand and then recheck offset.
- H. Seek track 0 (key CLR, RTZ) and check for dibit pattern (not in outer guard band)
- I. Seek track 822 (key 0822, LOAD,GO) and check for bal. dibit pattern (if either step H. or I does not show bal. dibit pattern you are off a track, restart at A)
- J. Recheck track 404 (key RTZ, CLR, 0404, LOAD,GO, CALCULATE OFFSET, LESS THAN 50 MILV, if not loosen head, fine adj. again)
- K. Check offset at track 8 for less than 350 milV (key CLR,008, LOAD,GO)
- L. Check offset at track 800 for less than 350 milV (key CLR,0800, LOAD, GO)(if step L or M off, fine adj.)

7.

ALIGNMENT of REMOVABLE DATA to REMOVABLE SERVO

- A. Sl of servo fine to D (looking at data head), Sl of align ext brd to normal (seeking off removable servo), seek track 0 (key RTZ) (data head previously loosened to 4 lb/)
- B. Seek track 404 (key CLR,0404,LOAD,GO)
- C. Rough adjust-adjust head till dibit pattern on scope is balanced
- D. Fine adjust-adjust head for meter reading as close to 0milV as possible
- E. Calculate offset-(as in step 6.f.) should be less than 50 milV
- F. Tighten down head to 12 lb/ guiding carriage making sure meter reading is less than +/- 50 milV and recheck offset (if off redo fine adjust)
- G. Key RTZ then recheck offset at 404 (key CLR,0404,LOAD,GO)
- H. Check offset at track 8 for less than 350 milV (key CLR,0008,LOAD,GO)
- I. Check offset at track 800 for less than 350 milV(key CLR,0800,LOAD,GO)(if step H or I is off, fine adjust again.)

OUTER GUARD BAND

OSCILLOSCOPE SETTINGS

LOGIC GROUND TO SCOPE GROUND

VOLTS/DIV

CH 1 - 0.5 V  
CH 2 - NOT USED

TIME/DIV

A - 0.5  $\mu$ s  
B - NOT USED

TRIGGERING

A - INTERNAL POSITIVE  
B - NOT USED

PROBE CONNECTIONS (USE X10 PROBE)

CH 1 TO FTU DIBITS JACK  
CH 2 NOT USED

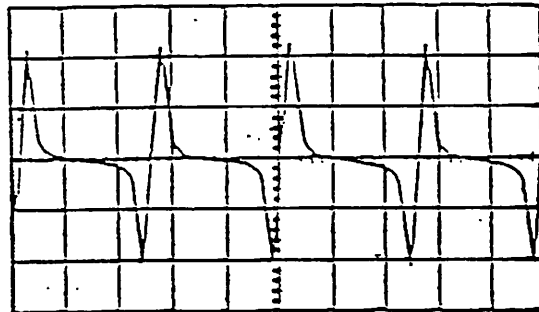

BALANCED DIBIT PATTERN (ON TRACK)

OSCILLOSCOPE SETTINGS

LOGIC GND TO SCOPE GND

VOLTS/DIV

CH 1 - 0.2 V  
CH 2 - NOT USED

TIME/DIV

A - 0.5  $\mu$ s  
B - NOT USED

TRIGGERING

A - INTERNAL POSITIVE  
B - NOT USED

PROBE CONNECTIONS (USE X10 PROBE)

CH 1 TO FTU DIBITS JACK  
CH 2 - NOT USED

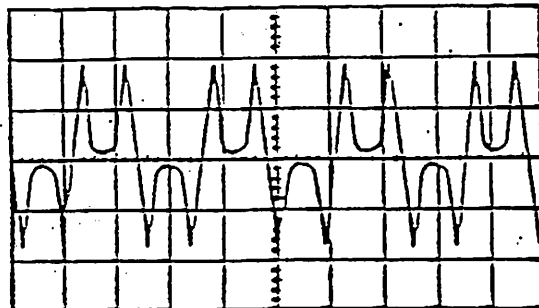



PHOENIX

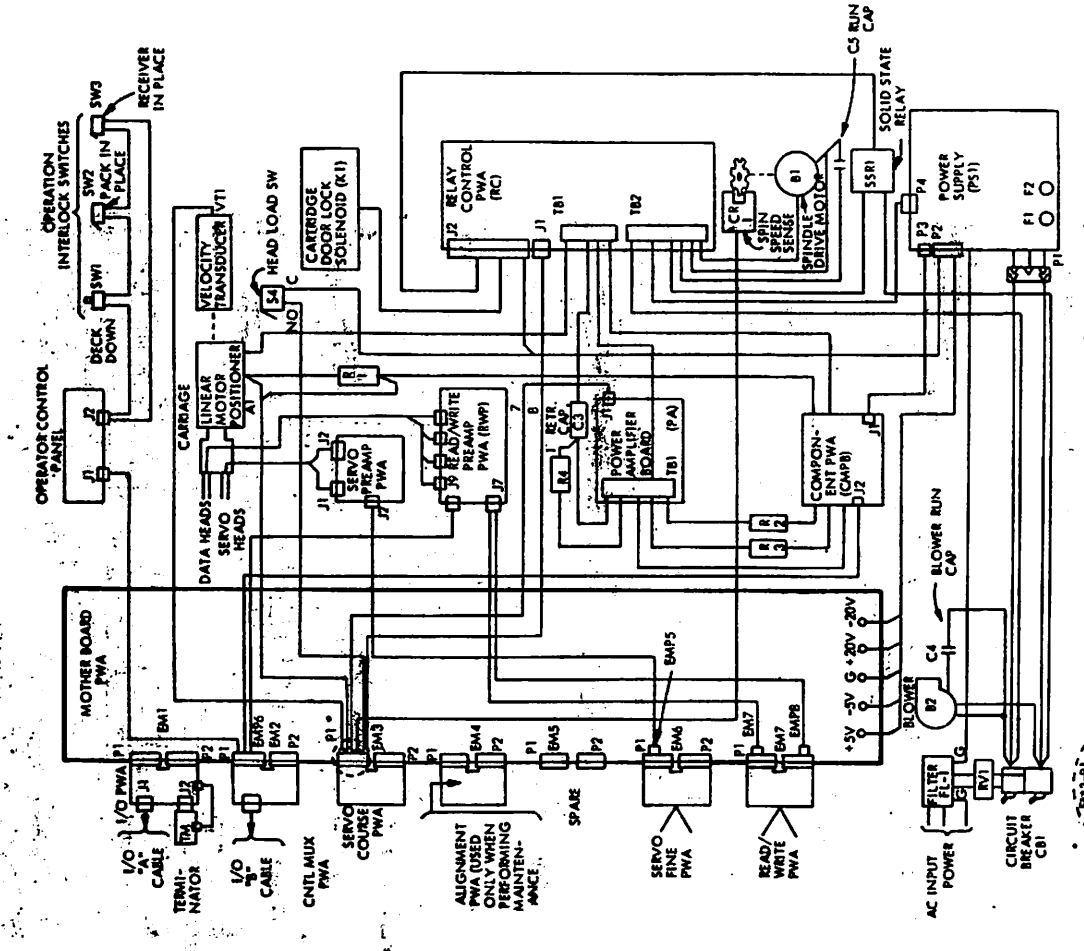

NOTE: SEE FIGURE 5-17 FOR DETAILED SCHEMATIC OF MOST OF THE CIRCUITS SHOWN HERE.

Figure 5-1. Intracabling Diagram (Sheet 1 of 2)

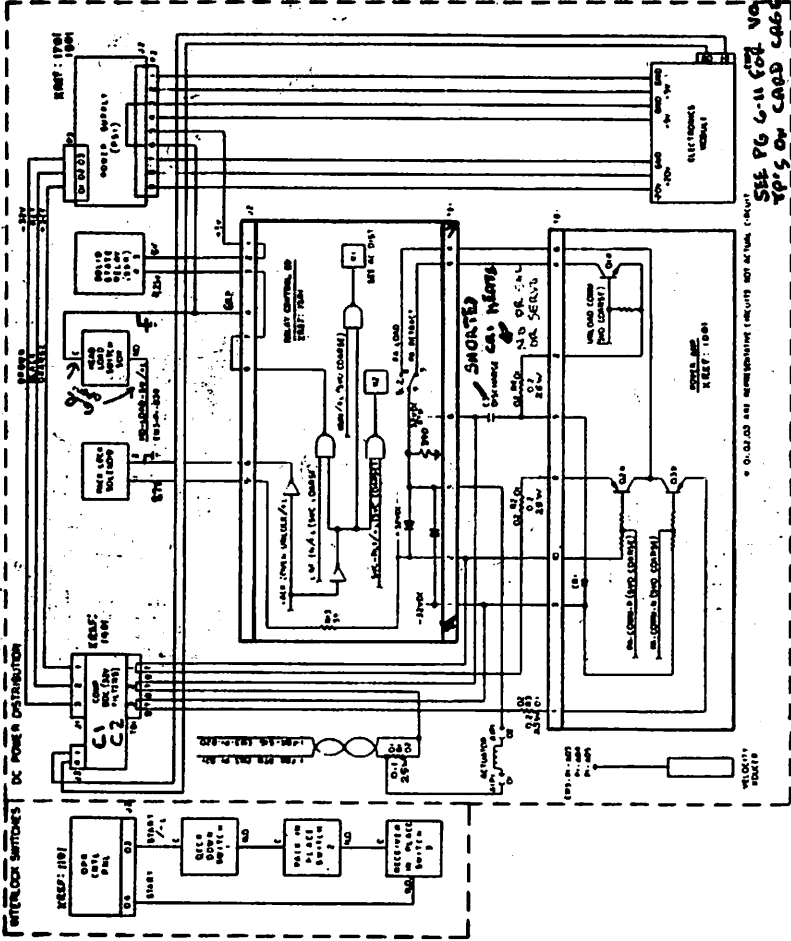

NOTES: \*\* Relay K1 shown in de-energized position.

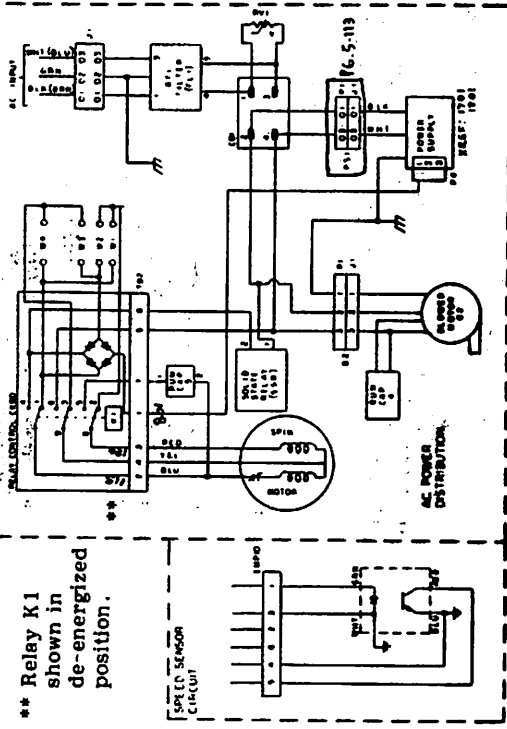

Figure 5-17. AC Power and DC Power Distrib. Interlock Switches and Speed Sensor CKT Diagram

CROSS REF NO. 1601

# PHOENIX BRDS

## I/O BOARD 626H6Z 726-5778

LOC. NORM 75891850 SERIES CODE 2 (UNIQUE TO WANG)  
 1 ON 77616751 SERIES CODE 2/3 (UNIQUE TO WANG)  
 NO SWITCH 77616770A VS88 W/ EITHER 22V28/V88 FAILED SW'S VOLTS IN SWITCHING  
 77616790  
 2,3,4 OFF 77622900 SERIES CODE 3 (UNIVERSAL)

### 726-6669

625C01 \* 77665650 SERIES CODE 4 (UNIVERSAL)

UPGRADE TO ALL LOC W/ BP3  
 COMPATIBLE BUT DIFFERENT  
 NEW BRDS IN NEW PRG  
 DIFFERENCES  
 W/ WANG  
 2/7/83

## CONTROL Mux 726-5779

U33 FLUX ENTIRE 90 <sup>CUT</sup> 60 <sup>CUT</sup> 30 <sup>CUT</sup> 77616600

1 OFF 77624700

2,3 ON (3 DIFF INVERT VOL) 726-6668

\* 77666950

\* POSSIBLE PROBLEMS IF INTERMIX  
 NEW BRDS W/ OLD BOARDS

## SERVO COARSE

### 726-5780

REV. 75885600

VS SW 1,4 OFF 2,3,5,6,7,8 ON 77622400

2200/OIS SW 7 OFF ON 77622401

77622402

77622403

77622750

420P

77666800

77666801

77682950

HAS J2 - (BETWEEN 022 & 027) IN - 90 SW FLUX OUT - 120 SW  
 J1 (TOP RIGHT) IN - LOSS OF ABC RECALIBRATION  
 OUT - LOSS OF ABC - MUST POWER OFF & ON

## RELAY BOARD

726-5786 BP 3 ONLY

726-6724 ← BP 4 ONLY → 726-6724A

75898850

77680650

77713900

726-6667

77634490

← NOT COMPATIBLE →

SC PROMS

5011-984-684

PLT LTS  
PLANNER

DON MCCARTHY

43382

726-5780

43370  
BILL MORELJSEY

726-5778

77616791

726-5779

77616600

NEW PROMS

5013 987 966

726-5780-1

726-6669

776-22500

726-6668

776-22501  
776-24700

BLOWER ON      START DEPRESSED      RUNNING

TB2 FLOWY

Color	Terminal	Blower On	Start Depressed	Running
BLK	7			
BLK	6	80 VAC	1.7 momentarily	111 VAC
WHT	5			
YEL	4	80 VAC	2.7 VAC	1.88 VAC
RED	3	80 VAC	1.7 momentarily	173 VAC
BLU/BLK	2	80 VAC	1.7 momentarily	111 VAC
PURP	1			

TB1

SELECTION CRITERIA

```

-----
PTR NUMBER -          START: C410002001                END: C410002001
PRIORITY:            ALL
PROBLEM TYPE:       ALL
RDB -               ASSIGN RDB: ALL          CUST RDB: ALL          ORIG RDB: ALL
HW/SW INDICATOR:   ALL
STATUS TYPE:       0
STATUS CODE:       ALL
-----

```

```

PROBLEM NUMBER:  C410002001      CUST NAME:          CATALANO INSURANCE AGENCY INC
PRIORITY         P1              CUST NUMBER:       00 00000305904
                                   CUST RDB:            3114

```

```

PROBLEM TYPE:     ESC              CUST CONTACT:      JULIE KIHEY
PRODUCT PROB NO: NOT LINKED      CUST CONT PHONE:  US-508-688-4667
                                   CUST ADDRESS 1:   251 BROADWAY
                                   CUST ADDRESS 2:
                                   CUST ADDRESS 3:
SYSTEM MODEL NO:  CS-5            CUST CITY:         METHUEN
GEN SYST MODEL:   2200 CS        CUST ST/PROV:      MA
O. S. VERSION:
HW MODEL NUMBER:  2280-3        CUST ZIP:          01844-0000
                                   CUST COUNTRY:

```

```

SW MODEL NUMBER:  RDB ASSIGNED:   8760
SW VERSION:       PERSON ASSIGNED: BAHIA MICHAEL E
PART NUMBER:     ORIG NAME:       PETRIV YURI S
PART NUM REV:    ORIG PHONE:      - - -

```

```

CALL TRKG DATE:  00/00/00        NETWORKED:          N
CALL TRKG NO:
ORG ACT/SYM/ACN:  RES DEPLOYED:
STATUS DATE:     09/20/89        DATE ENTER PTR:    09/20/89
STATUS CODE:     H O 495         DATE TO R&D:
STATUS ABBREV:   NEW PROBLM      WKDYS IN R&D:
                                   TOT WKDYS OPEN:      95.69

```

PROBLEM SUMMARY :PETRIV YURI S    DATE: 09/20/89    TIME: 08:17  
The system is left up and running all night. When the Cust. comes in ,in the morning, the disk drive has the fault light lite or they get an I91 at first accses. They then spin down , spin up and away they go . This does not happen every day only about once or twice a week.

ASSIGNED: BAHIA MICHAEL E        DATE: 02/01/90    TIME: 14:43  
Update acknowledged.

ASSIGNED: PETRIV YURI S         DATE: 02/01/90    TIME: 13:13  
D.S. installed shecduled to switch over in two weeks or so. ( I don't know.It has become a non-issue no failures reported by C.E. or cust. why don't we close it?

ASSIGNED: HALEY JOHN L         DATE: 02/01/90    TIME: 08:05  
Yuri, why are we dragging our feet on this?

ASSIGNED: BAHIA MICHAEL E       DATE: 01/08/90    TIME: 13:22



SELECTION CRITERIA

-----

PTR NUMBER -	START: C410002001	END: C410002001
PRIORITY:	ALL	
PROBLEM TYPE:	ALL	
RDB -	ASSIGN RDB: ALL	CUST RDB: ALL      ORIG RDB: ALL
HW/SW INDICATOR:	ALL	
STATUS TYPE:	0	
STATUS CODE:	ALL	

-----

PROBLEM NUMBER:	C410002001	CUST NAME:	CATALANO INSURANCE AGENCY INC
PRIORITY	P1	CUST NUMBER:	00 00000305904
		CUST RDB:	3114

TALKED W/ DTS. MTR WAS 50/60 HZ. ONSITE W/ BARRY FISH. 3RD MTR INITIALLY FAILED THEN STARTED WORKING. FAILED AGAIN W/ SAME PROB OF BLOWING CB. OLD MTR TO BE RE-INSTALLED.

ASSIGNED: BAHIA MICHAEL E      DATE: 11/30/89      TIME: 17:00  
Update acknowledged. Was motor a 50/60 hz. Left message for DTS to call.

ASSIGNED: HARRIS MARK A      DATE: 11/30/89      TIME: 07:24  
Motor has been replaced, will monitor drive and report any failures.

ASSIGNED: BAHIA MICHAEL E      DATE: 11/27/89      TIME: 16:27  
ptr # for motor prob on Px is C410002704. Checked audit trail & appears Jack Haley has call. Call should be sent to rdb 8765 / Barry Fish. Left message for DTS to call.

ASSIGNED: PETRIV YURI S      DATE: 11/27/89      TIME: 07:49  
~~ptr on motor problem is 410002705~~

ASSIGNED: BAHIA MICHAEL E      DATE: 11/22/89      TIME: 13:54  
REQUESTED PERIPHERAL GROUP CALL CDC FOR INFO ON MTR PROB. DTS TO ENTER PTR ON MTR PROB PER PERIPH GROUP REQUEST.

ASSIGNED: BAHIA MICHAEL E      DATE: 11/21/89      TIME: 17:12  
TALKED W/ DTS ON SITE. UNABLE TO INSTALL MTR AS THIS MTR TOO CAUSING CB TO POP ON SPIN UP. MTR WAS AGAIN A 50/60 HZ, VENDOR # 2834355008 (UNSURE OF 1ST #) & HAD EXACT SAME LABEL AS EXISTING DRIVE. OHMED OUT DRIVE:  
BLUE - RED BOTH WAYS = 10.5 OHMS  
RED - YELLOW BOTH WAYS = 7.7 OHMS  
BLUE - YELLOW BOTH WAYS = 2.8 OHMS  
BARRY FISH ON VAC THIS WEEK. LMTC. UNABLE TO GET HELP DIRECT FROM CDC.  
TALKED W/ KT. SUGGESTED TRYING LM TOMORROW OR WAIT TIL MON FOR BF.

ASSIGNED: PETRIV YURI S      DATE: 11/21/89      TIME: 13:25  
going on site to replace motor and relay pcb today 3:00 pm

ASSIGNED: PETRIV YURI S      DATE: 11/20/89      TIME: 08:36  
cust. had another fault light problem late friday. we will schedule motor replacement with cust.

ASSIGNED: PETRIV YURI S      DATE: 11/16/89      TIME: 09:30

ASSIGNED: BAHIA MICHAEL E  
ASSIGNED: HARRIS MARK A  
ASSIGNED: BAHIA MICHAEL E  
ASSIGNED: PETRIV YURI S  
ASSIGNED: BAHIA MICHAEL E  
ASSIGNED: PETRIV YURI S  
ASSIGNED: BAHIA MICHAEL E

SELECTION CRITERIA

MTR NUMBER -	START: C410002001	END: C410002001
PRIORITY:	ALL	
PROBLEM TYPE:	ALL	
RDB -	ASSIGN RDB: ALL	CUST RDB: ALL
HW/SW INDICATOR:	ALL	ORIG RDB: ALL
STATUS TYPE:	0	
STATUS CODE:	ALL	

PROBLEM NUMBER:	C410002001	CUST NAME:	CATALANO INSURANCE AGENCY INC
PRIORITY	P1	CUST NUMBER:	00 00000305904
		CUST RDB:	3114

Still Running fine. No problems.

ASSIGNED: BAHIA MICHAEL E      DATE: 11/14/89      TIME: 17:25  
 ON SITE W/ DTS FRI. TRIED TO CHANGE SPINDLE MTR FOR SPIN DOWN PROB. NEW MTR WHICH APPEARED TO BE EXACTLY SAME AS IN DRIVE WOULD POP CB ON SPIN UP. HAD TO PUT OLD MTR BACK. HAVE SEEN THIS MTR PROB BEFORE. DTS TO CONTACT B FISH ON MTR PROB. NEED MORE INFO FROM CUST ON PROB. REQUESTED CUST FOLLOW SPECIFIC PROCEDURE ON HANG FAILURE. SHOULD RESET EA W/S 1 BY 1 & TRY TO LIST DISK. NEED TO DOCUMENT WHICH W/S IF ANY WHEN RESET CLEARED PROB & IF SO WHAT PROG & SURFACE WAS IT ACCESSING. ALSO NEED TO DOCUMENT WHAT REMOVABLE PACK IN DRIVE AT TIME OF FAILURE. SOME RECENT PROBLEMS APPEAR TO BE DUE TO 1 PARTICULAR PACK. ENVIRONMENT DOES NOT APPEAR TO BE PROBLEM PRESENTLY BUT COULD BE IN FUTURE BECAUSE OF CABLING, CARPETING, & EQUIPMENT SETUP IN SMALL ROOM. ALSO, CONDITIONER IS HUMMING. WILL LOOK INTO THAT. THE LINE ANALYZER SHOWED SOME MARGINAL PROBLEMS WHICH APPEARED TO BE ASSOCIATED W/ POWERING DRIVE UP & DOWN. NO FAILURES COULD BE LINKED TO POWER. WILL TRY TO REPLACE MTR AGAIN SHOULD THE SPIN DOWN PROB RE-OCCUR.

ASSIGNED: PETRIV YURI S      DATE: 11/14/89      TIME: 09:38  
 still ok no problems

ASSIGNED: PETRIV YURI S      DATE: 11/13/89      TIME: 09:03  
 He where on site friday pm and changed relay pcb in the drive as it had not been tried befor. Also the regulator in the dpu was change for exsesive ripple @ 54 mv on the +12. The system was fine this A.M. and I will monitor and update at next occurence.

ASSIGNED: BAHIA MICHAEL E      DATE: 11/09/89      TIME: 08:16  
 Site visit arranged for 3 pm Friday.

ASSIGNED: PETRIV YURI S      DATE: 11/08/89      TIME: 12:42  
 Friday @ 3:00 pm ok

ASSIGNED: BAHIA MICHAEL E      DATE: 11/06/89      TIME: 08:21  
 JUST BACK FROM WEEK IN TRAINING. WILL PHONE TO CO-ORDINATE SITE VISIT.

ASSIGNED: PETRIV YURI S      DATE: 11/02/89      TIME: 15:17  
 drive pwr off by ce installing line analyzer befor message got through. today the customer had another fault light and I91 insident they spun down wred off and on to clear problem schdueling on site next wed or thursday

11/14/89  
 11/13/89  
 11/09/89  
 11/08/89  
 11/06/89  
 11/02/89



SELECTION CRITERIA

```

-----
PTR NUMBER -          START: C410002001          END: C410002001
PRIORITY:             ALL
PROBLEM TYPE:        ALL
RDB -                ASSIGN RDB: ALL          CUST RDB: ALL          ORIG RDB: ALL
HW/SW INDICATOR:    ALL
STATUS TYPE:         0
STATUS CODE:         ALL
-----

```

```

PROBLEM NUMBER: C410002001    CUST NAME:          CATALANO INSURANCE AGENCY INC
PRIORITY        P1           CUST NUMBER:       00 00000305904
                  CUST RDB:          3114

```

afternoon would you care to come along and see if there's any thing I've missed The pwr strip is on the way to the Area but it sounded ok as read by CE

ASSIGNED: BAHIA MICHAEL E DATE: 10/26/89 TIME: 09:42  
If that is the case the microprocessor should still have the flt. If the cust has not powered off the drive we can still get the flt. If this is the case please document the flt & update call.

ASSIGNED: PETRIV YURI S DATE: 10/26/89 TIME: 08:39  
They just spun down and up and resumed running.

ASSIGNED: BAHIA MICHAEL E DATE: 10/25/89 TIME: 13:01  
Talked w/ DTS. Flt lite on drive this AM & of course got error I91 when tried to access. Powered drive off & on & ok. No prob for about 2 weeks. Most likely environmental. Action plan is to leave Line Analyzer on drive until after next prob. Could be caused by power brown out. Must have cust notify us immediately on failure. Need to check uproc leds in drive before powered off.

ASSIGNED: PETRIV YURI S DATE: 10/25/89 TIME: 10:04  
This morning the cust had a fault light on the drive and got an I 91 when they accessed it . I propose that we reinstall a line analyzer, jumper out the interlocks . any more suggestions?

ASSIGNED: BAHIA MICHAEL E DATE: 10/17/89 TIME: 08:54  
TALKED W/ DTS. CUST SEEMS TO BE RUNNING FINE. DID HAVE 1 I91 (DRIVE NOT READY) ERROR DURING BACKUP LAST WEEK. THE I91 MAY HAVE BEEN A FLUKE ERROR CAUSED BY ELEC NOISE OR ENVIRONMENTAL INTERFERENCE OR POSSIBLY ACCESSING DRIVE INADVERTENTLY WHEN NOT READY. CUST HAS COMPLAINED ALSO OF THE SYSTEM SOMETIMES RUNNING SLOW. THIS MOST LIKELY IS DO TO WHAT IS BEING RUN ON THE SYS OR POSSIBLY DISK RETRIES. IF VERIFY EA SURFACE OF DISK & MINIMAL OR NO RETRIES OCCUR THAN THE PROB IS UNLIKELY TO BE RETRIES. IF CUST IS CONCERNED & NEEDS HELP WILL NEED TO DOCUMENT WHAT EA W/S IS DOING WHEN SYS SLOWS & IF AGREEABLE SHOULD KEY HALT AT EA W/S 1 AT A TIME TO SEE IF ANY 1 W/S FREES UP SYSTEM. WHEN HALTING W/S MUST WAIT TILL BOTH THE COLON & CURSOR RETURN TO BE SURE HALT HAS OCCURRED. CUST HAS BEEN RELUCTANT TO GIVE US SYSTEM SO FAR.

ASSIGNED: PETRIV YURI S DATE: 10/11/89 TIME: 11:59  
The cust. reports system running fine and has had no I91's in the morning. Backup's have run fine except for that one occurence. We will go back to

ASSIGNED: BAHIA MICHAEL E  
 DATE: 10/17/89 TIME: 08:54  
 TALKED W/ DTS. CUST SEEMS TO BE RUNNING FINE. DID HAVE 1 I91 (DRIVE NOT READY) ERROR DURING BACKUP LAST WEEK. THE I91 MAY HAVE BEEN A FLUKE ERROR CAUSED BY ELEC NOISE OR ENVIRONMENTAL INTERFERENCE OR POSSIBLY ACCESSING DRIVE INADVERTENTLY WHEN NOT READY. CUST HAS COMPLAINED ALSO OF THE SYSTEM SOMETIMES RUNNING SLOW. THIS MOST LIKELY IS DO TO WHAT IS BEING RUN ON THE SYS OR POSSIBLY DISK RETRIES. IF VERIFY EA SURFACE OF DISK & MINIMAL OR NO RETRIES OCCUR THAN THE PROB IS UNLIKELY TO BE RETRIES. IF CUST IS CONCERNED & NEEDS HELP WILL NEED TO DOCUMENT WHAT EA W/S IS DOING WHEN SYS SLOWS & IF AGREEABLE SHOULD KEY HALT AT EA W/S 1 AT A TIME TO SEE IF ANY 1 W/S FREES UP SYSTEM. WHEN HALTING W/S MUST WAIT TILL BOTH THE COLON & CURSOR RETURN TO BE SURE HALT HAS OCCURRED. CUST HAS BEEN RELUCTANT TO GIVE US SYSTEM SO FAR.

SELECTION CRITERIA

-----  
PTR NUMBER - START: C410002001 END: C410002001  
PRIORITY: ALL  
PROBLEM TYPE: ALL  
RDB - ASSIGN RDB: ALL CUST RDB: ALL ORIG RDB: ALL  
HW/SW INDICATOR: ALL  
STATUS TYPE: 0  
STATUS CODE: ALL  
-----

PROBLEM NUMBER: C410002001 CUST NAME: CATALANO INSURANCE AGENCY INC  
PRIORITY P1 CUST NUMBER: 00 00000305904  
CUST RDB: 3114

monitor mode.

ASSIGNED: PETRIV YURI S DATE: 10/10/89 TIME: 08:45  
yeah most likely one of the servo heads we put in has slipped or is a little flaky I'll schedule time with the cust. and me and mat will go in.

ASSIGNED: BAHIA MICHAEL E DATE: 10/06/89 TIME: 16:04  
SOUNDS LIKE A PX PROB. HAVE CUST DOC EXACTLY WHAT SURFACE WAS BEING BACKED UP & WHAT SURFACED COPIED TO. WILL BE IN TRAINING NEXT WEEK BUT WILL BE CALLING IN. RUNNING SLOW COULD BE DUE TO RETRIES ACCESSING DISK. WILL NEED TO VERIFY ALL SURFACES WATCHING FOR RETRIES & HEAVILY TEST BY RUNNING RANDOM R/W BETWEEN SERVOS.

ASSIGNED: PETRIV YURI S DATE: 10/06/89 TIME: 14:54  
The cust is back to leaving the system up at night we will see monday what happens. The bad news is that the system is running slow and they reported that the system froze during backup they hit reset load run return and got an 91. Maybe servo to servo?

ASSIGNED: BAHIA MICHAEL E DATE: 09/29/89 TIME: 15:25  
UPDATE ACKNOWLEDGED.

ASSIGNED: PETRIV YURI S DATE: 09/29/89 TIME: 12:46  
No I91 yesterday or today But the cust. is going to shut down over the weekend so monday will not be a valid test. The reason for the shut down is a file corruption issue from 3 weeks ago that redshaw is working. The cust. wants no more hardware work done until redshaw finishes cleaning out bad risk files and figures if they shut down there will be no I91 and no reason for us to work on it. so we are on hold and monitoring.

ASSIGNED: BAHIA MICHAEL E DATE: 09/27/89 TIME: 12:16  
SPOKE W/ DTS ON PHONE. SYS SEEMS TO BE RUNNING FINE AT THIS TIME. MONITORING.

ASSIGNED: PETRIV YURI S DATE: 09/27/89 TIME: 10:24  
oops! then the dpu dropped dead. It gave us I92's on first seek then work fine. As we trouble shoot this it changed to I91 on first seek then hang then it would work for 1 minute and end with an I90. We eliminated very thing but the dpu and fixed moduale then went home. We returned with my dpu hooked it up and reformated the surfaces, restored the cust data and every thing worked

SELECTION CRITERIA  
-----

PTR NUMBER -             START: C410002001                                     END: C410002001  
PRIORITY:                ALL  
PROBLEM TYPE:            ALL  
RDB -                    ASSIGN RDB: ALL                    CUST RDB: ALL                    ORIG RDB: ALL  
HW/SW INDICATOR:        ALL  
STATUS TYPE:             O  
STATUS CODE:             ALL  
-----

PROBLEM NUMBER:	C410002001	CUST NAME:	CATALANO INSURANCE AGENCY INC
PRIORITY	P1	CUST NUMBER:	00 00000305904
		CUST RDB:	3114

fine. This morning 9/27 no error where recorded we will continue monitoring every morning.

ASSIGNED: PETRIV YURI S             DATE: 09/27/89     TIME: 09:50  
We went onsite 9/26 4:00pm changed: pwr supply, pwr amp, fixed moduale, and b both servo heads then the dpu

ASSIGNED: PATTERSON MARY SUE     DATE: 09/25/89     TIME: 16:28  
escalating. district has been onsite three times, problem still occurring. "phantom I91", yuri has spoken with Mike Bahia. requesting assistance.

ASSIGNED: PETRIV YURI S             DATE: 09/25/89     TIME: 09:00  
Onsite this morning , A user got on the system :got in to the soft ware tried d to accses a risk file then got an I91. There was no external fault on the drive but the micro fault inside was the same except a different address . spun down and up and it work fine . We will go back at 4:00 pm to change servo heads , and pwr supply as not to impact cust operation.

ASSIGNED: PETRIV YURI S             DATE: 09/21/89     TIME: 12:32  
Cust. went down with I91 on 9/20 @ 4:00 pm while users where on the system. The micro. proucesser fault was the same, off track greater than 1200 micro seconds. I checked the ripple on the voltages in the dpu, they where fine, then I checked the rev's of the pcb, they were fine except the 7424. @ rev 7. When I put the dpu online to test it was dead. Not having dpu parts onsite I had to return in the morning. The 7424 pcb was the failing component and is now a rev 9 . Because the 7424 will not cause a servo fault in the drive we also replaced the servo preamp but not the heads as planned due to cust down time . Most of the down time was caused by a W.S. (believe it or not). It was hanging the the system at different points in IPL of redshaw software and giving p48,p57, and x75 on W.S.1 until it was shut off This W.S.(#5) is usually the first one on in the morning and has caused 2 hangs of the printer doing hot print . IT is offline . We will be onsite in the mornings for the next few day to monitor .

ASSIGNED: PETRIV YURI S             DATE: 09/20/89     TIME: 09:56  
went on site to check out mach. alignment was out of spec. static eliminator dirty,found losse wire on bottom of card cage,tighten and reseal all connecti on. will monitor @ next failure will change servo preamp.and servo heads.  
decode of micro proucesser fault was"off cyclinder for greater than 12

no work on  
the correct  
the morning  
the and 29ft  
us to work on  
  
 assigned: BAHIA  
FOKE WA DTG ON  
MONITORING  
  
 assigned: PETRIV  
the then the dr  
as we trouble  
with work for I  
and fixed modu  
and replaced the

SELECTION CRITERIA

-----  
PTR NUMBER - START: C410002001 END: C410002001  
PRIORITY: ALL  
PROBLEM TYPE: ALL  
RDB - ASSIGN RDB: ALL CUST RDB: ALL ORIG RDB: ALL  
HW/SW INDICATOR: ALL  
STATUS TYPE: 0  
STATUS CODE: ALL  
-----

PROBLEM NUMBER: C410002001 CUST NAME: CATALANO INSURANCE AGENCY INC  
PRIORITY P1 CUST NUMBER: 00 00000305904  
CUST RDB: 3114

ASSIGNED: PETRIV YURI S DATE: 09/20/89 TIME: 08:17  
not reproduceable except by proublem discription

RESOLUTION TEXT :BAHIA MICHAEL E DATE: 02/01/90 TIME: 15:04  
HC634. Last reported problem occurred before 1/8 & only 1 prob since mid  
Dec. DTS called in & wants to close call. Appears problem most likely  
caused by some outside disturbance. Motor replacement prob still exists but  
is no longer required here since drive is no longer failing. Transferring  
call back to field to be closed.

0-823 tracks 64 Sectors/track  
 823 reserved for end sector

52672 /SERFACE

2280 PROGRAMMING

FOUND DURING  
 \$ FORMAT -

ADDRESSING:	PLATTER	DRIVE 1	DRIVE 2
2280-1	26.9 MEG REMOVABLE 1st FIXED	/D10 OR /B10 /D11 OR /310	/D50 OR /B50 /D51 OR /350
2280-2	53.8 MEG 2nd FIXED 3rd FIXED	/D12 /D13	/D52 /D53
2280-3	80.8 MEG 4th FIXED 5th FIXED	/D14 /D15	/D54 /D55

\$FORMAT DISK 7/2/13

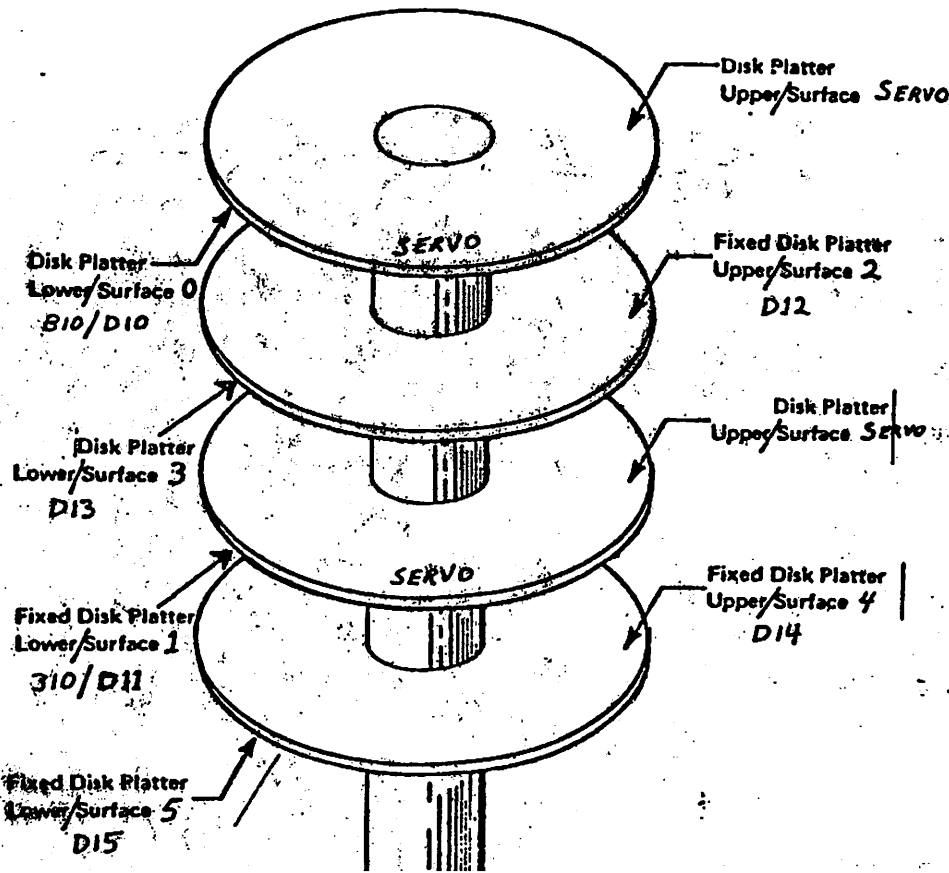

## The 2280 DPU and MUX DPU

- Make sure that all the FCO's and ECO's are done. Verify them with the enclosed ECO History Report. If they aren't done, do them. Bear in mind that it is imperative that all the customers platters be re-formatted after the installation of FCO 1168 (Rev. 10 Proms on the 7423A board) and that when doing FCO 1168, FCO 1161 (510 Ohm resistors at R46 and R48 on the 7422 board) must be done as well.
- Check to make sure that the "A" and "B" cables are shielded and that the cables are properly installed as shown in the attached figures. Check continuity between the I/O Controller rail and the Phoenix chassis.
- Check with an Ohmmeter that the Logic Ground is connected to the DPU chassis. Logic Ground and Frame Ground should have approximately zero Ohms on the drive, the DPU and the CPU. If there is resistance there a ground strap should be installed. (MAKE SURE YOU USE LOGIC GROUND AND NOT A VOLTAGE ETCH).
- Check all the screws on the power supply capacitors to make sure they are not loose. Also check all the screws and nuts that mount the power transistors and diodes to the heat sink. If there are any loose, tighten them and then recheck the voltages.
- Check the D.C. Voltages with a digital voltmeter. They should be checked on the 210-L567 Motherboard connector on the bottom of the motherboard and then verified on the motherboard etches at the last I/O connector. Use only Logic Ground not the Controller rails or the chassis when checking voltages.
- Check the A.C. ripple on the D.C. Voltages using an Oscilloscope (NOT A DIGITAL MULTIMETER) and be sure to ground the scope on Logic Ground, not on the metal of the chassis.
- Make sure that the screws on all parallel cables are snugly screwed to the connectors on the controllers. Extension cables from 25 to 1000 feet from DPU to CPU are only allowed on the Multiplexed systems between the 210-7717 Mux Master in the DPU and the 210-7715 Mux slave in the CPU. They must be securely screwed together with the screws and offsets. (NOT TAPED TOGETHER) The reason for screwing them together is to ground them as well as to hold them together.
- Extension data cables are not allowed on non Mutiplexed systems.

I have found that most of the problems that are encountered with the 2200 Phoenix disk drives are either Servo problems or Communications/Timing problems between the Drive and DPU or the DPU and CPU. Following is a list of the things that we have found and therefore these things should be checked when working on a Phoenix problem whether intermittent or solid.

Though this document was written with the 2200 System in mind the Adjustments, Grounding Procedures and troubleshooting techniques for the Phoenix Drive could be applied to the VS and OIS Systems.

## Things to Try and to Look For

Try to make the drive fail:

### NOTE

(THE FIRST AND MOST IMPORTANT THING TO DO IS MAKE SURE THAT THE FIXED VOLUME AND ANY CUSTOMER'S REMOVABLE PLATTERS THAT YOU WILL USE TO TEST THE DRIVE ARE BACKED UP)

If there is an intermittent hang or heads unload or a symptom of that nature, during backup or an application that does long seeks and rapid volume switches, there may be a servo to servo type problem. The first thing to do is to check all the drive adjustments. If they are all "perfect", (within spec may not always be close enough), Then there may be a board problem. There are no diagnostics that will switch volumes rapidly and the FTU accesses only one volume at a time. The following program will sometimes do the trick:

```
10 VERIFY T/D10,(0,0)
20 VERIFY T/D11,(52607,52607)
30 GOTO 10
```

If the drive is at 320 substitute D20 and D21 for D10 and D11

This makes the drive read sector 0 on the removable and sector 52607 on the fixed causing a maximum seek and a volume change. If there is a Servo to Servo problem it may show itself.

If it doesn't hang or unload with a C.E. Scratch pack try some of the Customer's packs. It may be a surface problem if not something in the drive. (Be sure any customer Rem packs are backed up)

If it only happens intermittently have the customer note which Removable Pack is in the drive at the times of the problems. Maybe some packs need cleaning.



Alternate Sector Maps:

Each platter on the drive has it's own Alternate Sector Map. With Rev. 10 Proms in the DPU, when the drive is first accessed after power-up the DPU reads the Alternate Sector Maps of all the Platters and keeps them in memory in the DPU. (This is why if you power up the drive, then LIST DCF, the drive does a couple of seeks. It goes to sector 52608 of the Rem. Cart. to get the Map, does a Return To Zero then a seek to the inner cylinder again to read all the maps for all the fixed platters).

To read the Alternate Sector Map for a platter this program will do it:

```
10 DIM A$(4)64
20 DATALOAD BAT/Dxx,(52608,L)A$()
30 PRINT HEXOF(A$())
Where "/Dxx" is the platter address.
```

If there are any alternate sectors on the platter the resulting printout will be of the form:

```
0000000004000000241301241402247B03247D0400000000000000000000000000
0000000000000000000000000000000000000000000000000000000000000000
0000000000000000000000000000000000000000000000000000000000000000
0000000000000000000000000000000000000000000000000000000000000000
0000000000000000000000000000000000000000000000000000000000000000
0000000000000000000000000000000000000000000000000000000000000000
0000000000000000000000000000000000000000000000000000000000000000
0000000000000000000000000000000000000000000000000000000000000000
0000000000000000000000000000000000000000000000000000000000000000
```

Where for example:

Byte No. 5 = 04 Meaning there are 4 Alternate Sectors  
Byte No. 9&10 = 2413 Location In Hex of a faulty sector  
Byte No. 11 = 01 Offset from 52608 of replacement  
sector. In the case of this platter there are four Alternate sectors, there is a bad sector at location 2413 and its replacement is at 52608+1=52609. There is another bad sector at 2414 and its replacement is at 52608+2=52610. Bear in mind that all the values in the Alternate Sector Map are in hex.

If there are no Alternate Sectors, Sector 52608 should give an error when it is verified.

## Phoenix Alignments and Adjustments

Check the option switches. There is a switchbank on the Control Mux. Board and on the I/O Board for system options and sectors per track switches on the Servo Coarse Board.

Make sure that all the ground straps are in place and that the system is properly grounded. AC and DC grounds must be strapped together at the rear of the basepan. The "A" and "B" cables must be shielded and their shielding must make good contact with the unpainted surface at the rear of the basepan. Do not use the green ground wire to ground the Phoenix to the DPU or System as well or there may be ground loops.

Check the voltages at the bottom of the Phoenix card cage making sure you use a good logic ground point.

Check the fixed module runout. There should be less than 2 volts peak to peak on test point 10 of the Servo Coarse board with test point 9 of Servo Coarse Board grounded, and a fixed data head selected. The symptoms will be servo problems such as heads unloading or drive hangs when rapidly switching volumes during seeks.

Check the Carriage Restraint Block Adjustment. A 0.001 shim stock should fit between the set screw and the block but a 0.003 should not. Could cause heads to unload and drive hangs and servo to servo alignment will not stay in.

Check the Fixed Servo to Cartridge Servo Head Alignment. Though the specifications state that 50 millivolts of offset is good enough we have found that with drives that have intermittent problems it is best to get the Servo to Servo to less than 20 millivolts. (As close to zero millivolts as possible) It is also easier to check this alignment with a null meter than it is using a digital multimeter.

Check that the heads are clean. Each district office has the new disk head inspector that works very well.

Verify the servo surfaces of the platters by monitoring the dibit signal with a scope and doing a cylinder by cylinder seek from 0 to 822. Surfaces that have a fuzzy or distorted dibit signal could cause servo problems such as hangs or heads unloading. Check to see if the customer has problems with all of his removable cartridges or only some of them. Maybe he could keep a log. Servo problems are most common during backup when the drive is constantly switching servo heads. If there are any suspect cartridges suggest that the customer remove them from use or have them cleaned.

Don't forget to check the Average Seek Adjustment.



COURSE HANDOUT

EQUIPMENT CATEGORY III A.7

PHOENIX DISK DRIVE

PROM COMPATIBILITIES - SERVO COARSE PCB

OLD PROMS

5011	984	964
---	used in Servo Coarse PCB	726-5780
these PROMS are)	I/O PCB 726-5778	CDC 77616791
used with )	C/M PCB 726-5779	CDC 7761660

NEW PROMS

5013	987	966
----	used in Servo Coarse PCB	726 5780-1
these PROMS are)	I/O 726-6669	(CDC 776-22500
used with )		( OR
	C/M 726-6668	(CDC 776-22501
		CDC 776-24700

When old and new PCB's are mixed the following faults can sometimes be produced, particularly on VS drives:-

1. Fault Light
2. Head Select
3. Servo Problems
4. Alignment Problems.

♦♦♦♦♦

FROM: JERRY SPENCER RDB: 3030

# I/O BOARDS

75891850 SERIES CODE 2 UNIQUE TO WANG

↓  
REPLACED BY

77616751 S.C. 2/3 UNIQUE WANG BOARD

77616790

↓  
REPLACED BY

726-5178 \* 77622500 S.C. 3 UNIVERSAL BOARD

LOW 2-4 OFF

↓ WAS THIS REPLACED BY 2501?

726-6669 \* 77665650 S.C. 4 UNIVERSAL BOARD

ALL BOARDS ARE UPWARD/DOWNWARD COMPATIBLE  
IT IS RECOMMENDED NOT TO USE OLD  
BOARDS IN NEW MACHINES DUE TO TIMING  
DIFFERENCES IN WANGS CONTROLLER (IOP)

? \* ALL SWITCHES OFF FOR WANG

# Phoenix PCB

Servo Course - 726-5780

CD #	Rep by.
*77622750	*77666800
*77666800	is interchangeable with *77666801
*75885600	
1 77622400	2 77622401      726-5780
3 77622402	77666800
*77666800	is interchangeable with *77622402
*77666801	is interchangeable with *77622403
*77682950	SERVO COARSE w/ PURGE TIME JUMBERS see TAC NL 41029 NORM - BOTH JUMBERS IN 1-2 + 3-4      3105

Relay Control 726-5686

75898850 rep by 77634490

77634490 rep by 77633300 (726-6667) 50Hz

Block Point 4. unit - 726-6724

77680650 rep by 77713900 (726-6724A)

R/w 726-5783 - NONE  
R/w Pre Amp 726-5784 - NONE  
R/w Power Amp 726-5785 - NONE BP 3 + below

I/O - ~~726-5778~~  
77665600 is rep by 77622500 - 726-6669

CTRL MUX - ~~726-5779~~  
77666950 rep by 77624700 - 726-6668

TAC

INFORMATION CALL

CONTROL NUMBER 06322000

CONTACT NAME LARRY MILLER POSITION CE  
ROB # 3412 TDX # PHONE # 301 296 1663 EXT #

SYSTEM TYPE VS 85 DEVICE TYPE 2280-3  
UTILITY NAME SOFTWARE LEVEL

METHOD OF CALL P T = TELEX, P = PHONE, M = MEMO, E = EMS  
HAS THE AREA OR DISTRICT BEEN CONTACTED  
N A = AREA, D = DISTRICT, B = BOTH, N = NONE  
IS THIS INQUIRY PERTAINING TO A NATIONAL ACCOUNT ?  
U Y = YES, N = NO, U = UNKNOWN

USE THE FOLLOWING AREA TO DESCRIBE THE SITE THAT CREATED THIS REQUEST  
CUST/OFFICE NAME PHONE #  
ADDRESS 3310 CITY STATE  
ON SITE CONTACT NAME

QUESTION (\*) / ANSWER (+)

\*EMP. # 32527.  
\*RE: OLD STYLE IO BOARD ON THE PHOENIX CAUSING PROBLEMS.  
11/18/86: CALLING IN TO DOCUMENT A PROBLEM.  
+A COMPATIBILITY PROBLEM HAS BEEN FOUND W/ CERTAIN VERSIONS  
+OF THE PX I/O BRD WHEN USED W/ CERTAIN SYSTEMS OR WANG DISK  
+CONTROLLERS. IN THIS PARTICULAR CASE A WORKING BP3 PX WAS  
+INSTALLED ON A VS85 AND SOFT ERRORS WERE GENERATED WHENEVER  
+VOLUMES WERE SWITCHED. THE ALIGNMENT OF THE DRIVE WAS  
+CHECKED 3 TIMES & WAS ALWAYS WELL WITHIN SPECS. CAUSE OF  
+THIS PROBLEM WAS THE I/O BRD, CDC # 77616770A. THIS IS AN  
+OLDER STYLE BRD W/ NO SW BANK & BLK CONNECTORS FOR THE A  
+CABLE & TERMINATOR. WHEN THE BRDS WERE 1ST REPLACED FOR  
+THIS PROBLEM A SIMILAR VERSION I/O BRD WAS USED & THE PROB-  
+LEM WAS STILL PRESENT. ANOTHER BP3 PX FROM THE OFFICE WAS  
+BROUGHT IN & USING THIS SAME TYPE I/O BRD ALSO FAILED. THE  
+PROBLEM OCCURRED W/ BOTH A 22V88 & THE 22V28, BUT THESE  
+SAME DRIVES WORKED FINE ON A VS65. ONCE THE CURE WAS FOUND  
+TO BE A NEWER VERSION OF THE I/O BRD W/ THE SW BK, OLDER &  
+NEWER VERSIONS OF THE OTHER CARD CAGE BRDS WERE TESTED BUT  
+NO DIFFERENCE WAS FOUND. THE CDC 77516770A I/O BRD WOULD  
+CAUSE SOFT ERRORS WHEN CHANGING VOLUMES W/ EITHER OLD OR  
+NEW CDC BRDS ON THE VS85 W/ EITHER A 22V28 OR A 22V88.  
+GIVING COPY OF CALL TO DJ.

(30MIN) MIKEB

WANG

TECHNICAL SERVICE BULLETIN  
SECTION: HardWare Technical

NUMBER: HWT 6140 REPLACES: N/A DATE: 06/17/86 PAGE 1 OF 1

MATRIX ID. 3112 PRODUCT/RELEASE# CDC Storage

TITLE: CDC Phoenix Voice Coils

PURPOSE:

To inform the field of the possibility of voice coils wired incorrectly.

EXPLANATION:

Recently a batch of Phoenix voice coils was received from the vendor wired backwards. The Lawrence stockroom has been checked, and all incorrectly wired voice coils have been purged from stock. This is believed to be an isolated incidence; however, some of these voice coils may have been shipped to the field.

To check if a voice coil is wired CORRECTLY, observe the voice coil where the copper wires are joined to the copper flex leads. One of the copper wires from the voice coil will be tagged with a No. 1. The wire tagged No. 1 will go to the black wire via the copper flex lead.

If you have received an incorrectly wired voice coil, return it to:

Wang Laboratories, Inc.  
45 Computer Drive  
Haverhill, MA 01830  
Attn: Diana Nelson - M/S 4116C

GROUP: Peripheral Hardware Support Group MAIL STOP: 0125

COMPANY CONFIDENTIAL

WANG Laboratories, Inc.



Per Phil Bellinghieri,

CF experienced a problem with a Phoenix drive taken from a VS-80 and installed on a VS-65.

It was experiencing intermittent VTDC errors.

CF corrected problem by setting the S2 switches on the control main board to the proper positions.

Pos 1 = off

Pos 2 & 3 = on.

Information found in hand book.

Bel/C

WANG

TECHNICAL SERVICE BULLETIN  
SECTION: HardWare Technical

NUMBER: HWT 5049      REPLACES: N/A      DATE: 03/05/85      PAGE 1 OF 01  
MATRIX ID. 3105      PRODUCT/RELEASE# Phoenix Disk  
TITLE: Absolute Filter Causing Airlflow Problems

Wang has been delivering an improved Phoenix absolute filter for approximately nine months. This filter is distinguished by new packaging and an orange gasket around the exhaust outlet. Another distinguishing feature is the stabilizing "toes" at the underside of the exhaust outlet. It has been reported that the air hose from the no-air plenum will sometimes get caught under one of the stabilizers. The air pressure will then be cut off and the drive disabled. Care should be exercised when installing a new filter to prevent the air hose from being cut off.

GROUP: Peripheral Hardware Support Group      MAIL STOP: 0125

COMPANY CONFIDENTIAL

WANG Laboratories, Inc.

TAC

PROBLEM CALL

CONTROL NUMBER CR252031

CONTACT NAME TONY LCN POSITION FET  
RCB # 3416 TDY # PHONE # 703 276 0034 EXT #

SYSTEM TYPE VS 75E DEVICE TYPE PHCNIX  
UTILITY NAME SOFTWARE LEVEL

METHOD OF CALL P T = TELEX, P = PHONE, M = MEMO, E = EMS  
HAS THE AREA OR DISTRICT BEEN CONTACTED  
N A = AREA, C = DISTRICT, B = BOTH, N = NONE  
IS THIS INQUIRY PERTAINING TO A NATIONAL ACCOUNT ?  
L Y = YES, N = NO, U = UNKNOWN

USE THE FOLLOWING AREA TO DESCRIBE THE SITE THAT CREATED THIS REQUEST  
CUST/OFFICE NAME UNITED LITHC PHONE # 703 876 2749  
ADDRESS 3219 CITY ARLINGTON STATE VI  
ON SITE CONTACT NAME

PROBLEM (\*) SOLUTION (+)

\*EMP.NO.: 22848

\*DISP.NO.: 955154

\*HAVING PROBLEMS WITH PHENIX DRIVE. WILL NOT WORK.

9/8/88: TRYING TO RUN A PX FROM A VS80 ON A VS75E. SEEMS  
TO RUN VERY SLOW. HAVE HAD PROBLEMS BEFORE MOVING  
THE PX FROM 1 CP TYPE TO ANOTHER. NEVER RESOLVED.  
MAY NEED TO INITIALIZE TO CORRECT. IS USING THE  
9416 BRD. POSSIBILITY IT MAY NOT BE SUPPORTED.  
LEFT CVX FOR MS TO CALL ME ON THIS. 3RD POSSIBLE  
PROBLEM IS THERE IS A PROBLEM W/ THE DA CR  
COINCIDENTLY W/ THE DRIVE. (20MIN) MIKEB

9/9/88: TALKED W/ MS. THE PX IS SUPPORTED ON THE VS75E AS  
WELL AS THE 9416 DISK CONTROLLER. CALLED CE'S OF-  
FICE & GAVE INFO TO BM TO PASS ON. (5MIN) MIKEE

9/9 1:50 AFTER BACKING UP SYS AND RE-INITIALIZE IT AND  
DRIVE IS WRK'G FINE CLOSE CALL VSP

+PROBLEM WAS ONLY W/ FIXED MODULE. INITIALIZING THE FIXED

+MODULE RESOLVED PROBLEM. CLOSE CALL /CE.

(5MIN) MIKEB

----- Reply -----

From: Jack L Haley  
Subject: Pheonix Fixed Modules

Jack - Please see attached trip report for current status on Mag Data. As Barry Fish has informed you, our next step is to review Xidex's repair procedure, as this too, is a repair source for fixed modules.

I realize the Field time and frustration involved with this quality problem however, I think you'll agree, I cannot "alert" the Field to a problem until I have facts to report. Since Barry's return from Mag Data, 2/18, we have initiated a purge notice and are in the process of publishing a TSB denoting the exact s/n's of modules that are defective.

Last Friday, Barry rejected most of the inventory in Tewksbury but can assist you in obtaining a good module if you still have a down situation (I couldn't find a TAC call). As with most purges, stock will be available on a limited basis until the vendor can rework defective stock. If Xidex is experiencing similar problems, another purge notice/TSB will be generated. Kim

----- Original Memo -----

Kim:

As you may already be aware of the field is experiencing severe problems with the replacement fixed modules from stock. A recent incident in Conn. where 5 modules had to be tried to obtain one which barely was within spec (servo adj) and now, per the attached memo, where we are on the sixth module and no progress. Barry Fish has been aware of these problems, but the situation continues to deteriorate. What is the action plan to deal with this problem, I would like a call tomorrow defining the solution and an alert to the field so that many hundreds of manhours are not wasted trying to fix problems that cannot be fixed.

Jack Haley  
Rtom NE Region

REGARDING THE PHOENIX FIXED MEDIA PROBLEM. THE RANGE OF SERIAL #'S FOR THE MAGNETIC DATA INC. FIXED MEDIA THAT IS CAUSING PROBLEMS IS THE FOLLOWING:

\*

MA532287 TO MA569208

\*

I WAS INFORMED THAT THE OTHER VENDOR, XIDEX, IS OF QUESTIONABLE RELIABILITY BUT ACCORDING TO PRODUCT SUPPORT, LESS OF A RISK. I HAVE A TAC CALL OPEN NOW WHERE A CE HAS TRIED 2 FIXED MODULES AND IS EXPERIENCING SIMILAR PROBLEMS AS MAGNETIC DATA. I BELIEVE THESE ARE XIDEX PACKS BUT NOT SURE. THE SERIAL #'S THE CE HAD WERE X00009536 AND X00009540. I AM MAKING AN ASSUMPTION THAT THE "X" REPRESENTS XIDEX. IF ANYONE CAN VERIFY THIS, LET US KNOW.

\*

MAGNETIC DATA MEDIA HAS BEEN PURGED AND GOOD MEDIA SHOULD BE AVAILABLE ACCORDING TO PRODUCT SUPPORT.

BILL C

# SKANSKA

Setuo to Setuo +100mV -90mV

Cyl 8 150mV -200mV

Cyl 404 112mV -15mV

Cyl. 800 135mV -55mV

data read out of specs on Rem.

DATA 400 400 mV

716-232-4010

DATA

8 -225mV  
404 -10mV  
800 -25mV

(Y) (U) (H) (J) (M) (N) (76)

6 7  
Y U  
H J  
N M

# HAZEN PAPER

Date 4/10/87

## DATA

1<sup>ST</sup> READING  
1/28/87  
10-15 MIN

Track	mv		
8	-75	60	
	-43	+18	Σ 61 135
404	-60	70	
	-29	+18	Σ 46 130
800	-110	110	
	-62	+62	Σ 124 220

## Servo

Track	mv		
8	-250	-240	0
	-55	+55	Σ 110 290
404	-78	+22	
	-6	-5	Σ 11 50
800	-800	-75	
	-75	+75	Σ 150 175

Yunout 1.15V.

2<sup>ND</sup> READING  
20 min

SERVO	Track	mv		
	8	-100	90	190
	404	-73	6	19
	800	-190	190	380

HAZEN  
METER

30 min

SERVO	P	N	OFFSET
8	176	-177	353
404	-47	40	87
800	-256	248	504

	P	N	
8	+35	-42	77
404	-26	+25	57
800	-200	+150	350

	P	N	
8	-75	+80	155
404	-140	+140	288
800	<del>-270</del>	+290	568

PHOENIX ALIGNMENT

1. PURGE UNIT and ALIGNMENT PACK (up to speed, servo disconnected)
2. CABLING (Disk and FTU off)
  - A. Install alignment extender brd in drive, slot 4, and alignment board into extender
  - B. Install 2 wire cable from Servo Fine (white to front) to R/W Preamp (white on top)
  - C. Install 8 wire cable from Servo Fine (Arrow points up and towards wire) to Alignment Extender Brd (Arrow points to rear of drive away from wire)
  - D. Install 3 ribbon cables between FTU and Drive.  
Small cable from J1 of Brd 2 in FTU (red wire to right) to I/O Brd (red wire on top) bottom of A connector via adapter cable.  
Medium cable from J3 of Brd 2 in FTU (red wire to right) to CONTROL/MUX Brd, B connector (red wire on top)  
Large cable from J2 of Brd 2 in FTU (red wire to right) to I/O Brd (red wire on top) top of A connector via adapter cable.
3. SWITCH SETTINGS (Setting up for removable servo alignment)
  - A. Alignment extender board: S1 to FXD (Load off fixed servo)
  - B. Alignment Board: S1 to N (negative polarity of alignment voltage)  
 S2 to RW (always RW with Phoenix)  
 S3 to X1 (Attenuation factor of alignment voltage)
  - C. Servo Fine: S1 to S (looking at servo head)
  - D. FTU: Data Entry to Device Type; R/W Select to Alignment; Access Select To Direct Seek

HEAD and RECORD to manual, START and RUN off  
 STEP-down; SINGLE/CONT.-cont; -+ to center; LATE/EARLY-center  
 WRITE FLAG-off; WRITE PROTECT-on; AM/SECTOR-sector; EOT STOP-off  
 ERROR OVERRIDES-off; SHIFT PATT/DATA PATT-data patt; SEQ PWR-off



4. INITIAL POWER ON

- A. Power on FTU
- B. Pull out card cage, loosen removable heads to 4 lb/(if fixed servo has been loosened, it should be centered and tightened to 12 lb/)
- C. Power on drive to LOAD (Alignment pack previously installed and purged)
- D. FTU-START and RUN switches to ON(3rd row down, 7 right most lites come on)
- E. FTU-key in 8905 (90 Meg), 8903 (60 Meg), 8901 (30 Meg)  
Key LOAD then SEL DRIVE (Busy light will flash till drive ready) set DATA Entry switch to destination
- F. Bring Drive to READY (Busy light stops blinking on FTU)

5. SCOPE and METER SET UP

- A. Scope: Ch 1- 50 mV/div to READ SIGNAL on Alignment Board  
Ground to chassis  
Sync on Ch 1, 1 microsec/div
- B. Volt Meter: 500 milV scale  
Positive lead to + TP. of Align Brd., Neg lead to - TP of Align Brd.

"CAUTION: WHEN TIGHTENING OR LOOSENING HEADS IT'S A GOOD IDEA TO HAVE HEADS UNLOADED"

6. ALIGNMENT of REMOVABLE SERVO to FIXED SERVO

- A. Key RTZ on FTU (heads should move slightly)
- B. Move R Servo Head to the outer guard band and back to track 0 using scope (first balanced dibit pattern) heads previously loosened to 4 lb/ (See diagram on next page)
- C. Key in CLR, 0404, LOAD, GO
- D. Rough Adj-Adjust head till dibit pattern on scope is balanced.
- E. Fine Adj-fine adjust head for meter reading as close to 0 Mil V as possible.
- F. Calculate offset-record meter reading, switch S1 of Align Brd. to P. Record reading, subtract readings, should be less than 50 MilV (if off, loosen, Fine Adj again)

EXAMPLE:

P reading (+25 milV)-N reading (+5 milV)=20 milV offset  
P reading (+25 milV)-N reading (-10 milV)=35 milV offset  
P reading (-5 milV)-N reading (-10 mil V)= 5 milV offset

- G. Tighten down head to 12 lb/ making sure meter reading is less than +/- 50 milV while guiding carriage with other hand and then recheck offset.
- H. Seek track 0 (key CLR, RTZ) and check for dibit pattern (not in outer guard band)
- I. Seek track 822 (key 0822, LOAD,GO) and check for bal. dibit pattern (if either step E. or I does not show bal. dibit pattern you are off a track, restart at A)
- J. Recheck track 404 (key RTZ, CLR, .0404, LOAD,GO, CALCULATE OFFSET, LESS THAN 50 MILV, if not loosen head, fine adj. again)
- K. Check offset at track 8 for less than 350 milV (key CLR,008, LOAD,GO)
- L. Check offset at track 800 for less than 350 milV (key CLR,0800, LOAD, GO)(if step L or M off, fine adj.)

7.

## ALIGNMENT of REMOVABLE DATA to REMOVABLE SERVO

- A. Sl of servo fine to D (looking at data head), Sl of align ext brd to normal (seeking off removable servo), seek track 0 (key RTZ) (data head previously loosened to 4 lb/)
- B. Seek track 404 (key CLR,0404,LOAD,GO)
- C. Rough adjust-adjust head till dibit pattern on scope is balanced
- D. Fine adjust-adjust head for meter reading as close to 0milV as possible
- E. Calculate offset-(as in step 6.f.) should be less than 50 milV
- F. Tighten down head to 12 lb/ guiding carriage making sure meter reading is less than +/- 50 milV and recheck offset (if off redo fine adjust)
- G. Key RTZ then recheck offset at 404 (key CLR,0404,LOAD,GO)
- H. Check offset at track 8 for less than 350 milV (key CLR,0008,LOAD,GO)
- I. Check offset at track 800 for less than 350 milV(key CLR,0800,LOAD,GO)(if step H or I is off, fine adjust again.)

OUTER GUARD BANDOSCILLOSCOPE SETTINGS

LOGIC GROUND TO SCOPE GROUND

VOLTS/DIV

CH 1 - 0.5 V  
CH 2 - NOT USED

TIME/DIV

A - 0.5  $\mu$ s  
B - NOT USED

TRIGGERING

A - INTERNAL POSITIVE  
B - NOT USED

PROBE CONNECTIONS (USE X10 PROBES)

CH 1 TO FTU DIBITS JACK  
CH 2 NOT USED

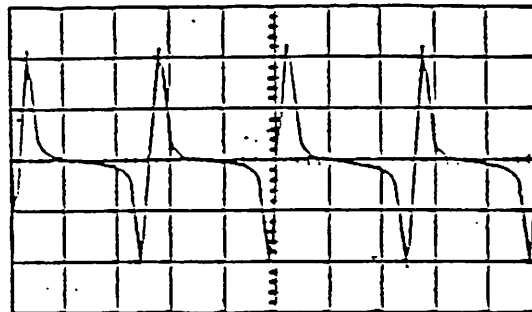
BALANCED DIBIT PATTERN (ON TRACK)OSCILLOSCOPE SETTINGS

LOGIC GND TO SCOPE GND

VOLTS/DIV

CH 1 - 0.2 V  
CH 2 - NOT USED

TIME/DIV

A - 0.5  $\mu$ s  
B - NOT USED

TRIGGERING

A - INTERNAL POSITIVE  
B - NOT USED

PROBE CONNECTIONS (USE X10 PROBES)

CH 1 TO FTU DIBITS JACK  
CH 2 - NOT USED

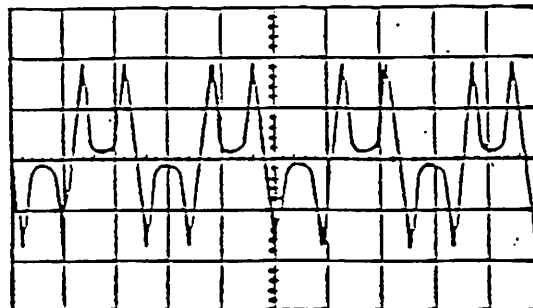

P.O. Box 12313  
Oklahoma City, Oklahoma 73157

Title: \_\_\_\_\_  
ECO Number TO BE ASSIGNED FCO Number NOT-APPLICABLE

Affects: CMD ALL HPC'S

1. Reason for the Change:

1. PROVIDES OPTION TO ALLOW CAPABILITY TO SAFELY UTILIZE ABSOLUTE FILTER FOR MAXIMUM LIFE REDUCING MAINTENANCE COST.
2. TO IMPROVE MAINTENANCE AND REDUCE MEAN TIME TO REPAIR (ENHANCED MTTR).
3. ENHANCEMENTS FOR CONSISTENT AND IMPROVED QUALITY.
4. RELOCATE ±32 VOLT SENSE POINT TO A MORE EFFECTIVE AND ACCESSABLE LOCATION.
5. INTRODUCE NON ADJUSTABLE DECK-IN-PLACE SWITCH.

2. This Change Affects the Following (where checked):

- a. Unit Specification (to meet)       b. Unit Interface  
 c. Unit Exterior Appearance       d. Unit Interchangeability       e. Spare Parts List       f. T & D Spec

3. Brief Summary of the Change:

1. MODIFIED DESIGN TO ALLOW AS AN OPTION, LOW AIR/NO AIR INDICATION & UNIT SHUT DOWN AT END OF FILTER LIFE.
2. RELAY CONTROL PWA REDESIGNED TO FUNCTION WITH 50 OR 60 HZ POWER & SCREW ON TERMINALS CHANGE TO PLUG CONNECTORS.
3. IMPROVED DESIGN OF CARTRIDGE RECEIVER ASSEMBLY.
4. IMPROVED DESIGN OF ELECTRONICS MODULE.
5. INTERNAL CABLES REROUTED & TERMINATIONS TO RELAY CONTROL AND POWER AMP PWA CHANGED TO QUICK, RELIABLE, PUSH-ON CONNECTORS.
6. MODIFIED DESIGN OF POWER AMP PWA TO RELOCATE ± 32 VOLT SENSE POINT.
7. CHANGE MECHANICALLY OPERATED DECK-IN-PLACE SWITCH TO MAGNETICALLY OPERATED SWITCH FOR ENHANCED PRODUCT RELIABILITY.

4. Specific Change to the Unit and/or Part Numbers, and Special Comment, as Follows:

SEE ATTACHMENT "A"

5. Effectivity (ECO/FCO, Class):

DUE TO TIME REQUIRED TO ALLOW FOR ADEQUATE TESTING AND MATERIAL AVAILABILITY, THIS BLOCK POINT CHANGE (SERIES CODE 4) WILL BE CUT-IN TO PRODUCTION DURING THE 4TH QUARTER, 1981.

CLASS II NEC -- INFORMATION ONLY

MPI Originator <i>Joseph M. Adrepta</i>	Date <i>7-9-81</i>	MPI Approval <i>Joe Ruben</i>	Date <i>7/10/81</i>
--	-----------------------	----------------------------------	------------------------

Notification of  
Engineering Change  
ATTACHMENT "A"

LOW AIR/NO AIR OPTION

- 1. PROVIDES, AT ADDITIONAL CHARGE, FACTORY INSTALLED OPTION WHICH IS DESIGNED TO PROVIDE THE CUSTOMER A WARNING WHEN THE ABSOLUTE FILTER REQUIRES CHANGING. IF THE FILTER IS NOT CHANGED PRIOR TO REACHING MINIMUM AIR PRESSURE, OR IF THE BLOWER MOTOR FAILS, THE UNIT WILL SPINDLE DOWN. CONTACT YOUR CDC OEM SALES REPRESENTATIVE, OR ACCOUNT MGR FOR PRICING AND AVAILABILITY INFO.

THEORY OF OPERATION

THE LOW AIR OPTION LOGIC IS ENABLED AFTER THE HEADS ARE LOADED. IF THE AIR PRESSURE IS LOWER THAN THE SETTING OF THE FIRST PRESSURE SENSOR, THE FRONT PANEL FAULT LED WILL FLASH AT A TWICE PER SECOND RATE TO GIVE THE OPERATOR AN INDICATION THAT SERVICE IS REQUIRED. THE UNIT WILL REMAIN OPERATIONAL TO ALLOW A ROUTINE SERVICE CALL FOR REPLACEMENT OF THE FILTER.

IF THE AIR PRESSURE FALLS BELOW THE SETTING OF THE SECOND SENSOR, THE INTER-LOCK SWITCH CIRCUITRY WILL OPEN WHICH WILL PREVENT THE DRIVE MOTOR FROM STARTING. IF THE UNIT IS IN THE READY STATE, OPENING THE INTERLOCK CIRCUITRY WILL UNLOAD THE HEADS AND STOP THE SPINDLE.

POWER AMP PWA (ILLUSTRATION ON PAGE 5) 726-6723

- 1. REPLACE TERMINAL STRIP AND DIP SOCKET WITH THREE INDIVIDUAL CONNECTORS (ELIMINATES MISWIRES AND DAMAGED PINS, REDUCES MTTR & IMPROVES MAINTAINABILITY).
- 2. MOVE POWER RESISTOR FROM BASE PAN TO POWER AMP PWA (DELETES WIRES).
- 3. THE ±32 VOLTS IS CRITICAL TO THE OPERATION OF THE SERVO SYSTEM. THEREFORE, THE ±32 VOLT SENSING POINT WAS MOVED FROM THE COMPONENT PWA TO THE POWER AMP PWA WHERE IT IS MORE EFFECTIVE AND ACCESSABLE.
- 4. NEW POWER AMP PWA IS COMPATIBLE WITH PREVIOUS SERIES CODE UNITS VIA ADAPTER KIT AVAILABLE AT NOT CHARGE.
- 5. PREVIOUS SERIES CODE-POWER AMP PWA IS NOT COMPATIBLE WITH SERIES CODE FOUR POWER AMPS.

RELAY CONTROL PWA (ILLUSTRATION ON PAGE 6) 726-6724

- 1. REPLACE TERMINAL STRIP AND DIP SOCKET WITH SEVEN INDIVIDUAL CONNECTORS (ELIMINATES MISWIRING AND DAMAGED PINS DURING PRODUCTION AND FIELD REPLACEMENT. REDUCES MTTR & IMPROVES MAINTAINABILITY).
- 2. PROVIDES COMMON HIGH VOLTAGE/LOW VOLTAGE CIRCUITRY WITH VOLTAGE SELECTABLE JUMPER PLUG (REDUCES SPARE PWA TYPES REQUIRED).

Notification of  
Engineering Change

## ATTACHMENT "A" (CONTINUED)

3. LOW AIR/NO AIR OPTION LOGIC AVAILABLE ON RELAY CONTROL PWA - (SEE LOW AIR/NO AIR OPTION ABOVE).
4. NEW RELAY CONTROL PWA WITHOUT LOW AIR/NO AIR OPTION IS COMPATIBLE WITH PREVIOUS SERIES CODE UNITS VIA ADAPTER KIT AVAILABLE AT NO CHARGE.
5. PREVIOUS SERIES CODE RELAY CONTROL PWA IS NOT COMPATIBLE WITH SERIES CODE FOUR RELAY CONT. PWA.
6. PROVIDES TWO STYLES OF RELAY CONTROL PWA - (A) LOW AIR/NO AIR OPTION INCLUDED AND (B). LOW AIR/NO AIR OPTION NOT INCLUDED.

MOLDED RECEIVER ASSEMBLY

1. REPLACE MULTIPLE PIECE ASSEMBLY WITH INJECTION MOLDED ASSEMBLY.  
(A) ENHANCES PRODUCT QUALITY AND REDUCES MTTR.  
(B) IMPROVED TOP COVER/RECEIVER ASSEMBLY CLEARANCE.

MOLDED ELECTRONICS MODULE ASSEMBLY (ILLUSTRATION ON PAGE 7) 726-6725

1. REPLACE MULTIPLE PIECE ASSEMBLY WITH INJECTION MOLDED ASSEMBLY.
2. ELECTRONICS MODULE RAISES WITH BASE DECK AND/OR LIFTS OUT PER CURRENT MAINTENANCE POSITION, THUS MINIMIZING POTENTIAL FOR CABLE DAMAGE.
3. ENHANCED CABLING THROUGH NEW HARNESS DESIGN AND ROUTING:  
(A) READ/WRITE PRE-AMP TO ELECTRONICS MODULE.  
(B) BASE PAN TO ELECTRONICS MODULE.  
(C) DECK TO ELECTRONICS MODULE.  
(D) POWER AMP TO ELECTRONICS MODULE.
4. REDUCES MTTR AND ENHANCES PRODUCT QUALITY, IMPROVES MAINTAINABILITY OF 2 & 3 ABOVE.
5. SERIES CODE FOUR ELECTRONICS MODULE INCLUDING BACKPANEL IS NOT COMPATIBLE WITH PREVIOUS SERIES CODE UNITS.
6. PREVIOUS SERIES CODE ELECTRONICS MODULE, INCLUDING BACKPANEL, ARE NOT COMPATIBLE WITH SERIES CODE FOUR UNITS.

Notification of  
Engineering Change

ATTACHMENT "A" (CONTINUED)

DECK-IN-PLACE SWITCH

- (A) REPLACE CURRENT DECK-IN-PLACE MICRO SWITCH LOCATED IN THE BASEPAN WITH A MAGNETICALLY ACTUATED REED SWITCH MOUNTED ON THE COMPONENT BD. MAGNET USED TO ACTUATE THE REED SWITCH WILL BE MOUNTED TO THE BASEDECK ABOVE THE COMPONENT BD.
- (B) IMPROVES PRODUCT QUALITY AND RELIABILITY, REDUCES MTTR.
- (C) SERIES CODE FOUR DECK-IN-PLACE SWITCH IS NOT COMPATIBLE WITH PREVIOUS SERIES CODE UNITS.
- (D) PREVIOUS SERIES CODE SWITCHES ARE NOT COMPATIBLE WITH SERIES CODE FOUR UNITS.
- (E) REFER TO SERIES CODE FOUR PRODUCT MAINTENANCE MANUAL FOR NEW SWITCH ID.

REC

Notification of  
Engineering Change

726-6723

PWA, POWER AMP SERIES CODE FOUR

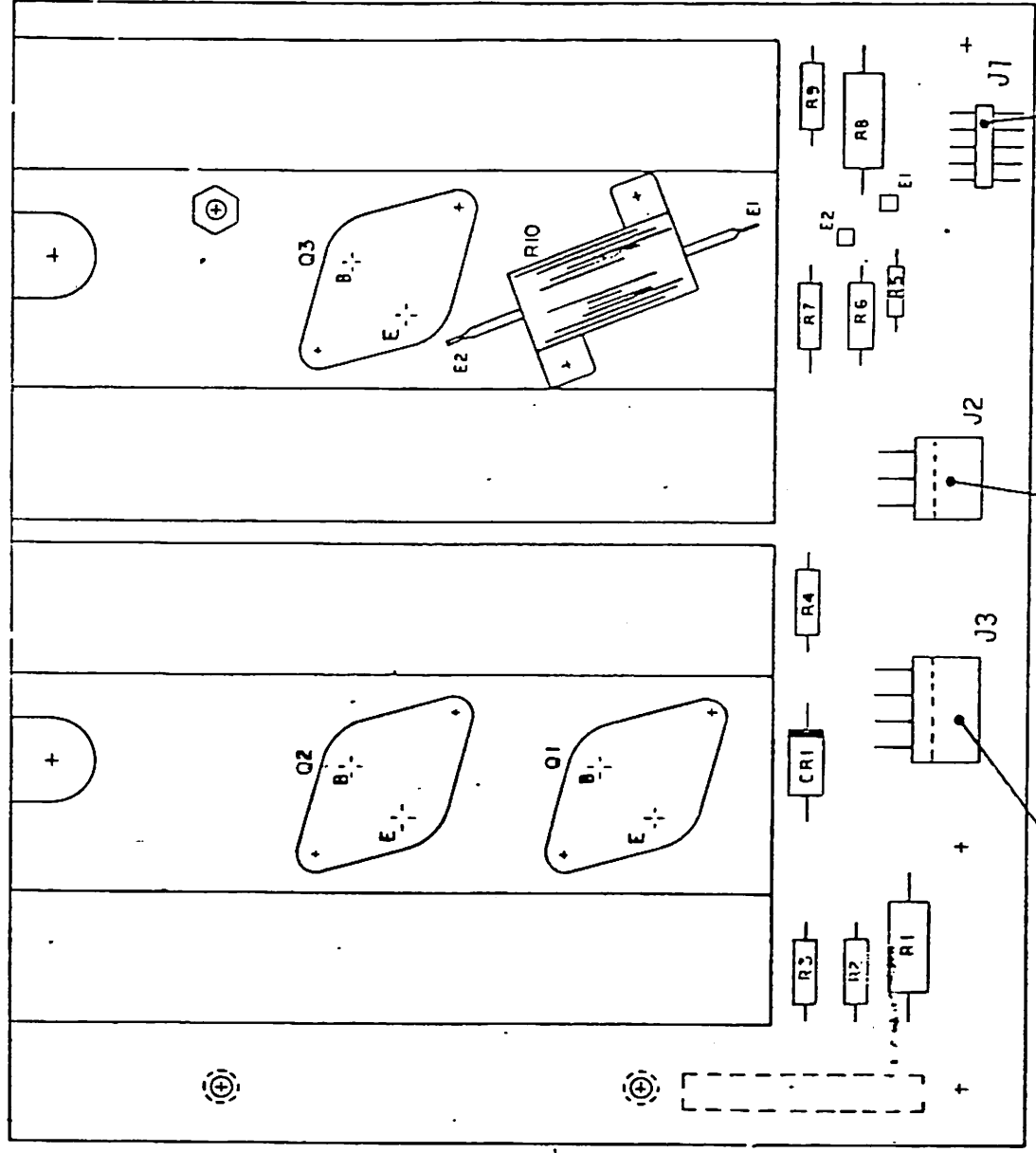

CONNECTOR TO E-MODULE

CONNECTOR TO RELAY CONTROL PWA

CONNECTOR TO RESISTOR MOUNTING BRACKET



Notification of  
Engineering Change

726-6724

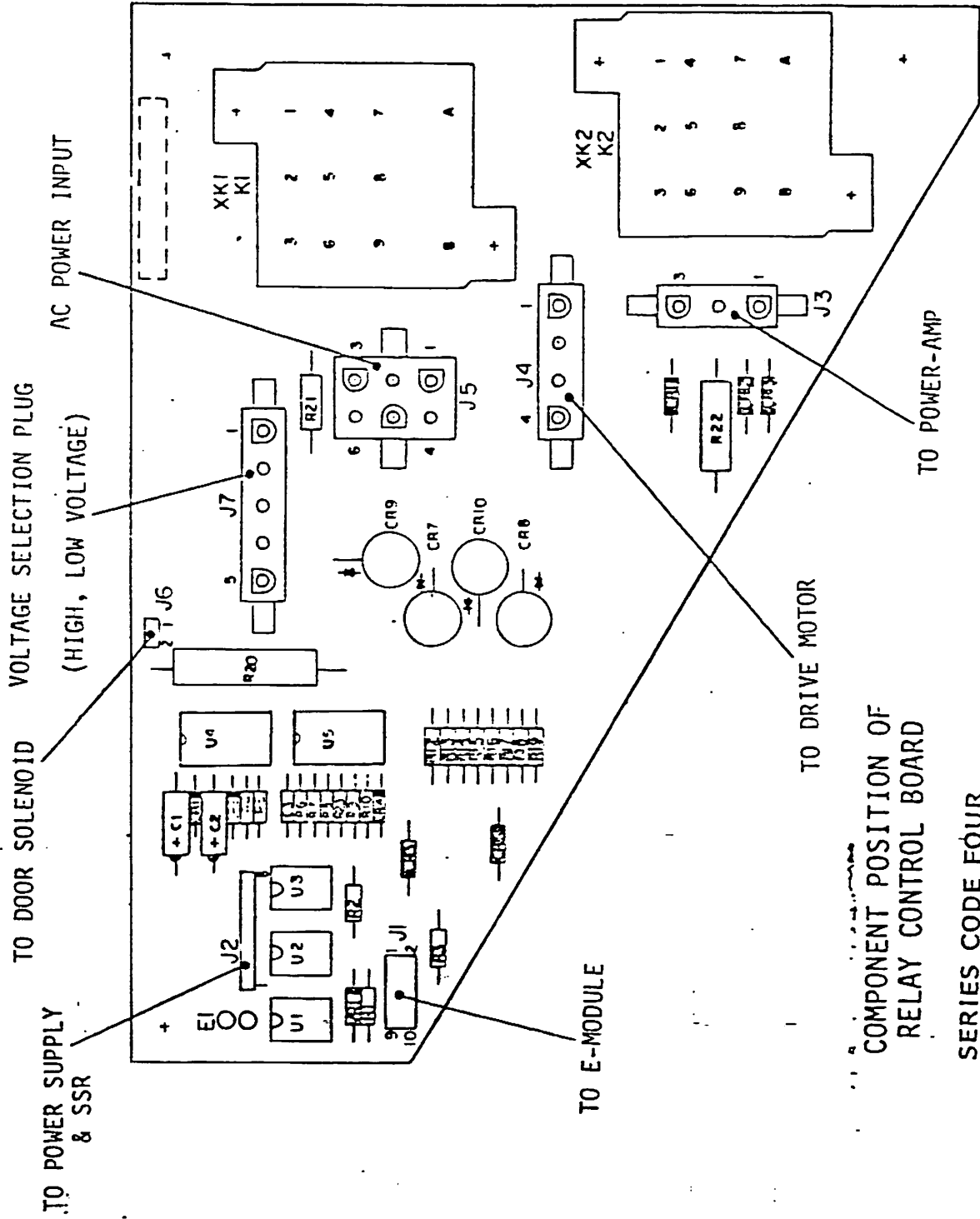

COMPONENT POSITION OF  
RELAY CONTROL BOARD  
SERIES CODE FOUR  
WITH LO AIR/NO AIR OPTION

## Notification of Engineering Change

SERIES CODE FOUR  
E-MODULE ASSY.

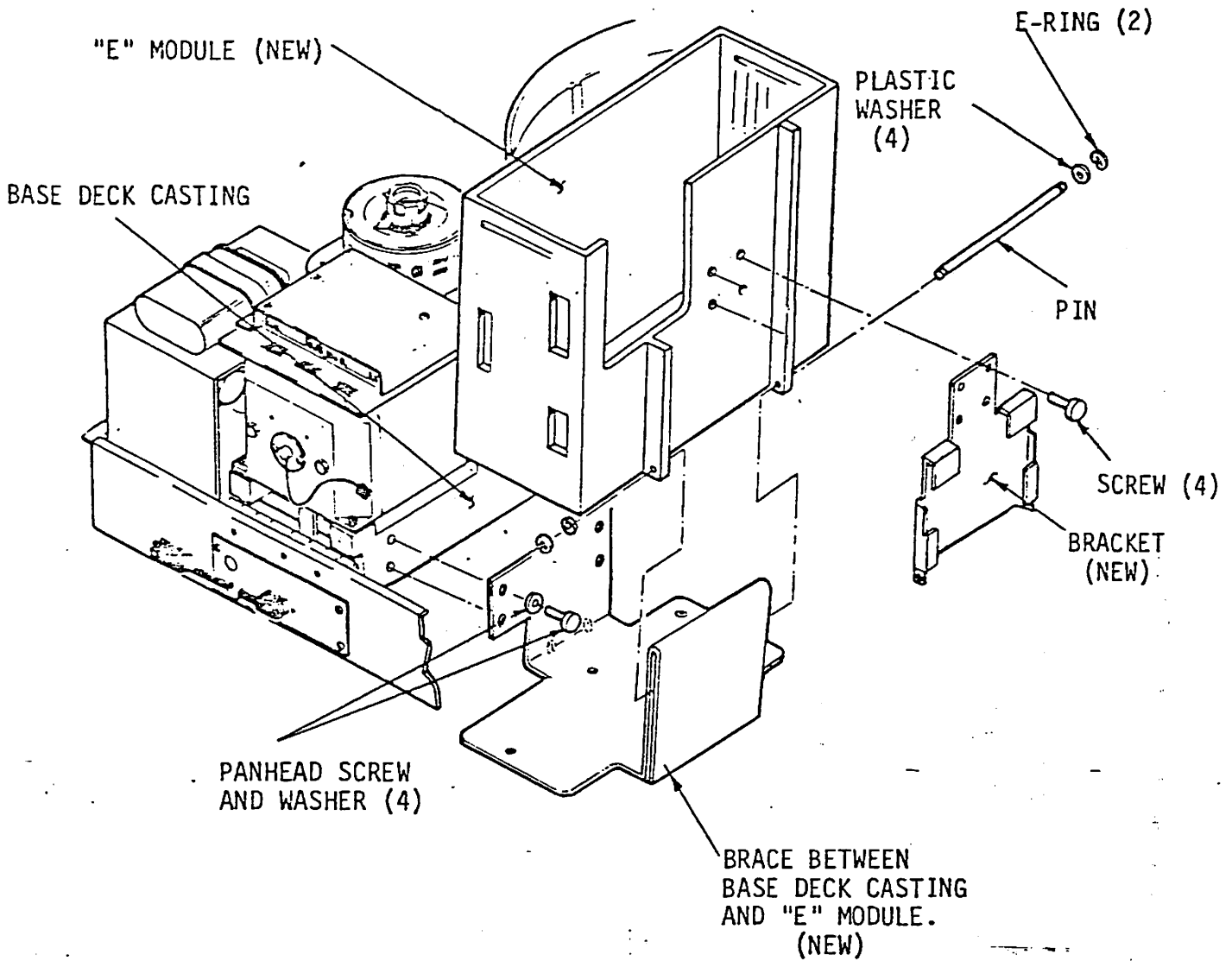

M-E-M-O-R-A-N-D-U-M

ATS, DTS, BMS  
FYI  
gk

ATOM's

FROM: DON CARSON/LAWRENCE/MSB235A

DATE: February 24, 1982

SUBJECT: PHOENIX BLOCK POINT 4 PART NUMBERS

The part numbers for the parts used in the Block Point 4 Phoenix Disk Drive are as follows:

Power Amp BP4	726-6723	
Relay Board BP4	726-6724	77680650
Card Cage BP4	726-6725	
Drive Mtr. Ass'y BP4	726-6726	

As there is no stock at this time in Home Office supply, please use discretion when ordering as they have to be drop shipped from CDC.

Regards,

Don Carson

DL/sq/0293A

## Spindle Height Measurement

It is generally recommended to check stack height at six month intervals. However, adverse conditions such as heavy usage or a recent move may require more frequent measurements.

1. Remove the cartridge receiver assembly and place the bar gauge on the spindle so that the ends overlap the edge of the deck assembly.
2. Place the dial gauge on the bar. While holding it steady, depress the top plunger and check that it calibrates to zero. If not, loosen thumb screw and rotate the face until it does.
3. Position the dial gauge on the bar so that it will penetrate the end hole and touches the drive casting.
4. Again, while holding the dial gauge steady, depress the plunger and take measurements at the following locations
  - a. Head load area
  - b. Front door latch area
  - c. Left side
  - d. Right side

All readings should be  $.313 \pm .004$

5. If any reading was out of spec, the spindle should be replaced.
  - A. If the spindle was just installed, check measurements again without the drive belt in place. If the reading changes, the spindle may have to be replaced again.

CUSTOMER ENGINEERING  
TECHNICAL ASSISTANCE CENTER  
NEWSLETTER

#20302

III.A.7

PERIPHERALS-DISK DRIVES-CDC PHOENIX 9448 CMD.

TOPIC: PHOENIX: BLOCK POINT 4

The new Phoenix Drive is arriving in the field at this time. There are a few changes with the drive that make it a little different from the old Phoenix.

- A. The chances of a head crash due to lack of or restricted air flow through the filter has been reduced. When the absolute filter (726-5758) reaches the end of usefulness or the blower motor fails, an air pressure sensor will cause the heads will retract and bring the drive down. The drive will not come ready until the problem has been corrected. Only use the filters that have the red plug at the exhaust end of the filter. This is where the sensing tube is placed.
- B. There are three new boards in the drive that are not compatible with the older units. The Relay Board, Component PCB and the Power Amp all now have plug connectors on them and cannot, at this time, be used in series code 3 and below drives. New Wang part numbers have been issued for the following boards:  
  
Power Amp BP4 726-6723  
Relay PCB BP4 726-6724.  
Component PCB. BP4 (not yet available )
- C. Cabling internal to the drive has been changed to accomodate the plug connectors on the new Power Amp and Relay Boards.  
The component PCB has a new deck down switch attached to it. Which is activated by a magnet on the deck assembly.
- D. The new OEM Manual P/N is 729-1063.

A This new manual is now in printing and should be available soon.

TECHNICAL SERVICE BULLETIN  
SECTION: Hardware Technical

NUMBER: HWT 5002 REPLACES: N/A DATE: 01/08/85 PAGE 1 OF 01

MATRIX ID. 3105 PRODUCT/RELEASE# CDC Phoenix

TITLE: Phoenix Disk Filter

PURPOSE:

To alert Field of head crash possibility.

An error in the manufacturing process of the Phoenix Disk Filter, WLI P/N 726-6846, has been discovered. The problem is the hole where the no-air plenum plugs into the filter. Drilling the hole caused a burr. When the orange plug is installed, it breaks off the burr introducing it into the exhaust cavity of the filter. If the filter is installed in a Phoenix it can cause a crash condition.

This problem is with filters manufactured by International Filter Corporation only!

These filters can be identified by a sticker with the logo IFC International Filter printed on it. The sticker is on the side of the filter, just behind the air plenum plug.

If you must open the box to identify the filters in question, DO NOT open the plastic bag.

Return any of these filters to your local Logistics Group.

GROUP: Peripheral Hardware Support Group

MAIL STOP: 0125

COMPANY CONFIDENTIAL

WANG Laboratories, Inc.

TECHNICAL SERVICE BULLETIN  
SECTION: HardWare Technical



NUMBER: HWT 8031      REPLACES: \_\_\_\_\_      DATE: 03/15/88    PAGE 1 OF 1  
MATRIX ID. 3105      PRODUCT/RELEASE# CDC Phoenix F/R Disk Drive  
TITLE: Purge of Spindle Motor (WPN 726-6726)

PURPOSE:  
To inform the field of Purge Notice #880016.

EXPLANATION:  
For an undetermined time, Logistics was stocking and shipping the Phoenix Spindle Drive Motor (WPN 726-6726, CDC P/N 77638604) with a 50Hz pulley instead of a 60Hz pulley. To identify which Spindle Drive Motors to purge, note the CDC part number stamped on the pulley itself. The following are the pulley part numbers:

Correct	60Hz Pulley	CDC Part Number - 75899707
Incorrect	50Hz Pulley	CDC Part Number - 75899706

If you have a motor with the wrong pulley, please ensure it is purged from local stock according to the purge notice.

GROUP: Desktop Systems/Peripheral Support Group      MAIL STOP: 001-140

COMPANY CONFIDENTIAL  
WANG Laboratories, Inc.

PHOENIX BP4

SPINDLE MOTOR 726-6726

w/ MOTOR SUPPRESSOR BRD (<sup>1 1/2" x 3"</sup> PARTIALLY UNDER RELAY BRD)

1 WIRE FROM START CAP GOES TO IT.

60 Hz MOTOR WORKED

50/60 Hz MOTOR WOULD NOT WORK

} SAME P/N

CAPACITANCE WAS DIFFERENT BETWEEN MTR  
BLOWS CB TRYING TO SPIN UP AFTER 10-15 SEC

CAL BLACKBURN <sup>DTS</sup> HAD PROB w/ 2 Px's



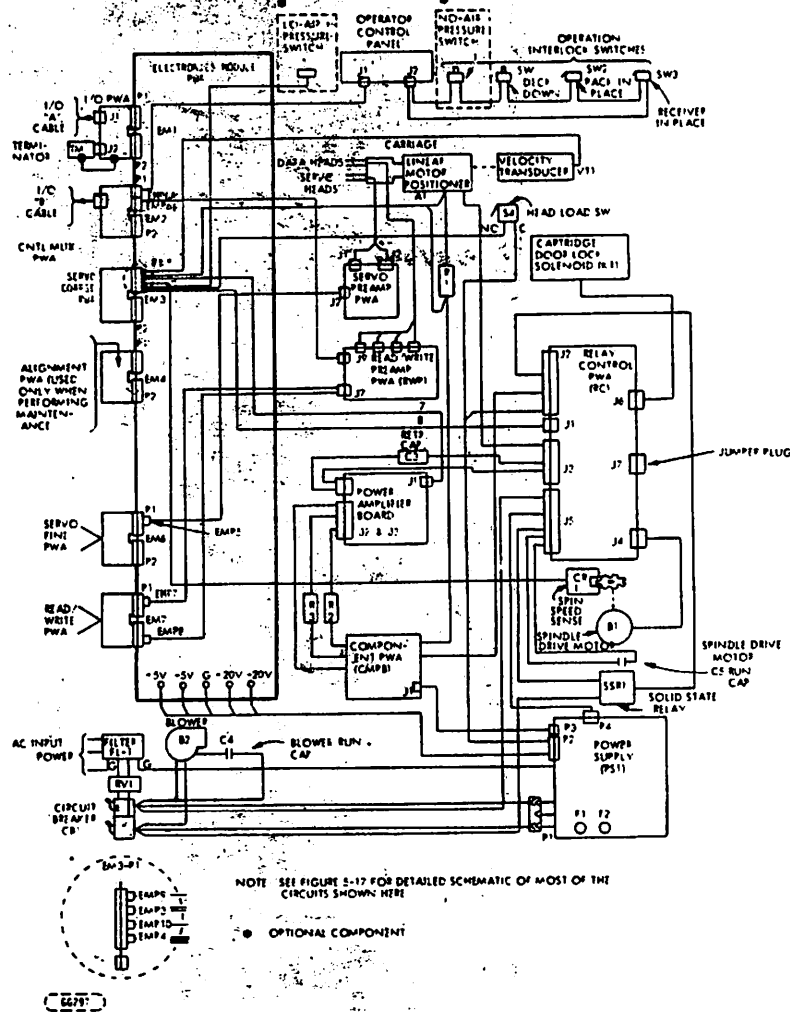

BP4  
FIGURE 5-1. INTRACABLING DIAGRAM (SHEET 1 OF 2)

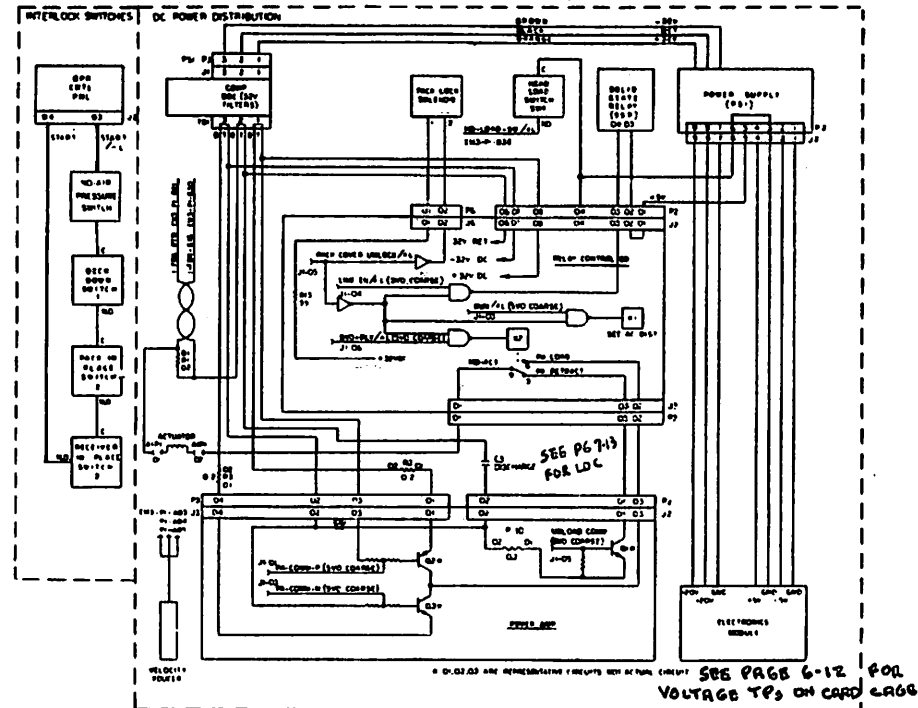

FIGURE 5-17. AC POWER AND DC POWER DISTR, INTERLOCK SWITCHES AND SPEED SENSOR CKT DIAGRAM

REVISION STATUS OF SHEETS

	1	2	3	4	5	6	7	8	9	10	11	12	13	14	15	16	17	18	19	20	
A																					
B																					
C																					
D																					
E																					

PART NO.	CD	DESCRIPTION
75155700	0	KEY
01	8	1 BY FMD LOGIC STD OEM
02	6	1 BY FMD NON-LOGIC
04	2	1 BY FMD LOGIC-BZ7E1-J,K
05	9	1 BY FMD LOGIC-BZ7E2-J,K
06		1 BY FMD LOGIC-BZ7E1-P,R
07		1 BY FMD LOGIC-BZ7E1-W,Y

REVISIONS					
REV	ECO	DESCRIPTION	DRFT	DATE	CHK'D
A	PE23000	RELEASED		1-5-79	
B	PE21428	CREATE BZ7E3	MF	8-4-80	
C	PE21727	ADD DPAR	CB	1-9-81	
D	PE21794	ADD TABS FOR BZ7E2	ELJ	2-25-81	
E	DHO2443	ADD TABS FOR BZ7E1-P,R	DLF	11-6-82	

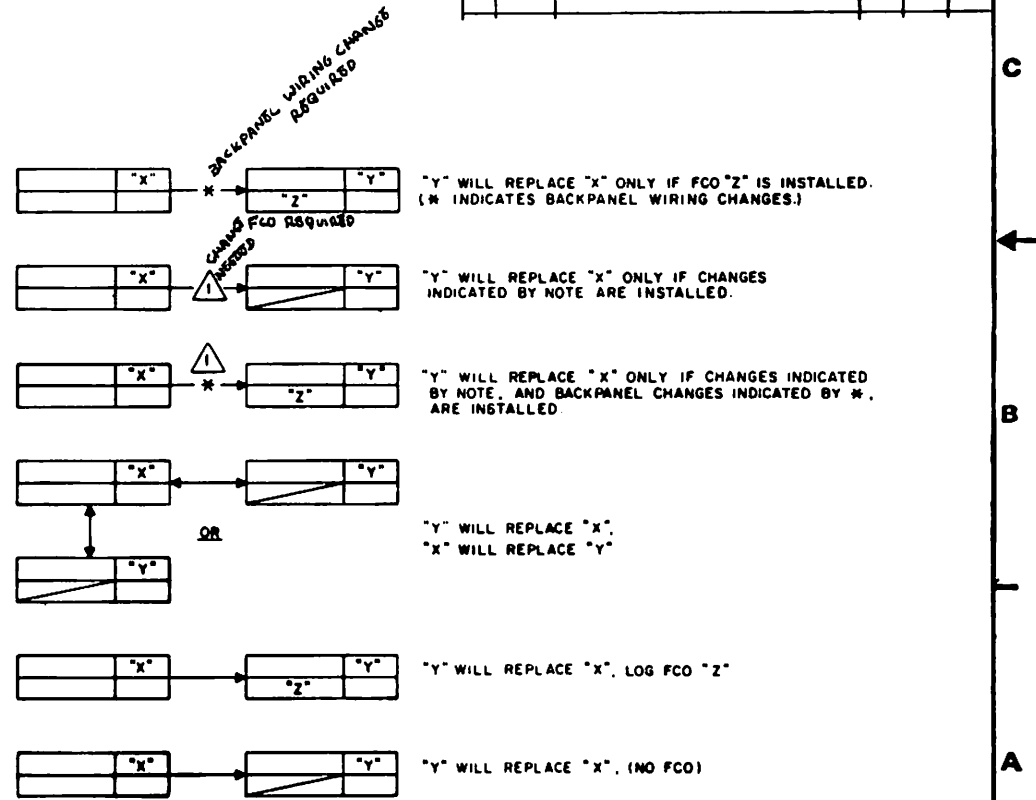
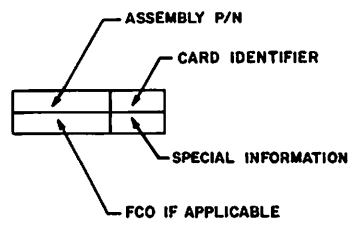

DRAWN <i>Duren, M.</i> 4-30-79	CONTROL DATA	CODE IDENT	C	83323560	J E
CHECKED <i>Peter N. Hall</i> 5-14-79		19333			
ENGINEER <i>J. E. Finn</i> 5/11/79	LARGE DISK DIVISION	CROSS REF NO		SHEET 1 of 1	PAGE 3D-3
APPROVED					

## Spindle Height Measurement

It is generally recommended to check stack height at six month intervals. However, adverse conditions such as heavy usage or a recent move may require more frequent measurements.

1. Remove the cartridge receiver assembly and place the bar gauge on the spindle so that the ends overlap the edge of the deck assembly.
2. Place the dial gauge on the bar. While holding it steady, depress the top plunger and check that it calibrates to zero. If not, loosen thumb screw and rotate the face until it does.
3. Position the dial gauge on the bar so that it will penetrate the end hole and touches the drive casting.
4. Again, while holding the dial gauge steady, depress the plunger and take measurements at the following locations
  - a. Head load area
  - b. Front door latch area
  - c. Left side
  - d. Right side

All readings should be  $.313 \pm .004$

5. If any reading was out of spec, the spindle should be replaced.
  - A. If the spindle was just installed, check measurements again without the drive belt in place. If the reading changes, the spindle may have to be replaced again.

SELECTION CRITERIA

-----

PTR NUMBER -	START: C200006422	END: C200006422
PRIORITY:	ALL	
PROBLEM TYPE:	ALL	
RDB -	ASSIGN RDB: ALL	CUST RDB: ALL
HW/SW INDICATOR:	ALL	ORIG RDB: ALL
STATUS TYPE:	0	
STATUS CODE:	ALL	

-----

PROBLEM NUMBER: C200006422	CUST NAME: FIRST OHIO SAVINGS BANK FSB
PRIORITY P3	CUST NUMBER: 00 00001627298

PROBLEM TYPE: INFO	CUST CONTACT: MIKE BIRON CE ONSITE
PRODUCT PROB NO: NOT LINKED	CUST CONT PHONE: -513-641-1891
	CUST ADDRESS 1: 4921 VINE ST
	CUST ADDRESS 2:
	CUST ADDRESS 3:

SYSTEM MODEL NO: 2200MVP-12	CUST CITY: CINCINNATI
GEN SYST MODEL: 2200 MVP	CUST ST/PROV: OH
O. S. VERSION:	CUST ZIP: 45217-0000
HW MODEL NUMBER: 2280-3	CUST COUNTRY:

SW MODEL NUMBER:	RDB ASSIGNED: 8760
SW VERSION:	PERSON ASSIGNED: BAHIA MICHAEL E
PART NUMBER:	ORIG NAME: PLANTE VIRGINIA
PART NUM REV:	ORIG PHONE: - - -

CALL TRKG DATE: 00/00/00	NETWORKED: N
CALL TRKG NO:	RES DEPLOYED:
ORG ACT/SYM/ACN:	DATE ENTER PTR: 05/05/89
STATUS DATE: 05/05/89	DATE TO R&D:
STATUS CODE: H O 495	WKDYS IN R&D:
STATUS ABBREV: NEW PROBLM	TOT WKDYS OPEN: 30.17

PROBLEM SUMMARY :PLANTE VIRGINIA DATE: 05/05/89 TIME: 12:49  
ee 21920 DISP 494275 OFC 513-786-8265 HAVING TRBL WITH SPINDLE MOTOR

ASSIGNED: BAHIA MICHAEL E DATE: 06/19/89 TIME: 10:32  
PLEASE CLOSE CALL: CLOSE CODE IS HC142. (5MIN) MIKEB

ASSIGNED: BAHIA MICHAEL E DATE: 05/10/89 TIME: 12:23  
HAVE SEEN PROB BEFORE ON BP4 PX W/ MOTOR SUPPRESSOR BRD. THIS BRD IS FOUND PARTIALLY UNDER RELAY BRD & HAS WIRE FROM START CAP TO IT. PROB PREVIOUSLY FOUND WAS 50/60 HZ MTR WOULD POP THE BREAKER WHILE THE 60 HZ MTR UNDER SAME P/N WORKS. CE TO CHECK PX FOR MTR SUPPRESSOR BRD & TRY TO HAVE LOGISTIS HAND PICK 60 HZ DRIVE FROM STK. IF THIS IS CASE AGAIN WILL TRY TO GET BF TO SETUP SEPARATE P/N'S FOR 50/60HZ & 60 HZ MTRS. MTR P/N IS 726-6726.(45MIN) MIKEB

ASSIGNED: PLANTE VIRGINIA DATE: 05/10/89 TIME: 09:10  
HE IS THE SHOP # 516-786-8265 or digital pager is 513-589-9565

ASSIGNED: BAHIA MICHAEL E DATE: 05/05/89 TIME: 15:56

SELECTION CRITERIA

-----  
PTR NUMBER - START: C200006422 END: C200006422  
PRIORITY: ALL  
PROBLEM TYPE: ALL  
RDB - ASSIGN RDB: ALL CUST RDB: ALL ORIG RDB: ALL  
HW/SW INDICATOR: ALL  
STATUS TYPE: 0  
STATUS CODE: ALL  
-----

PROBLEM NUMBER: C200006422 CUST NAME: FIRST OHIO SAVINGS BANK FSB  
PRIORITY P3 CUST NUMBER: 00 00001627298

TALKED W/ THE CE- CAUS HAD A NIOSEY SPINDEL MOTOR.  
THEY REPLACED IT W/2 NEW ONES THE NEW ONES WILL TRIP THE BREAKER OVER  
A PERIOD OF TIME. USUALLY WHEN THE CUST DOES A BACKUP AND THE MOTOR HAS  
TO SPIN UP. CE WANTS TO KNOW WHAT THE READING IS ON THE WINDINGS  
TRIED CALLING B FISH FOR ANY INFO ON THE PX MOTOR.

ASSIGNED: PLANTE VIRGINIA DATE: 05/05/89 TIME: 12:49

RESOLUTION TEXT :BAHIA MICHAEL E DATE: 06/19/89 TIME: 10:28  
HC 142. REINSTALLED ORIGINAL MTR & TIGHTENED UP & NOT AS NOISY. DOES NOT  
KNOW IF DRIVE HAS MTR SUPPRESSOR BRD OR NOT: CLOSE CALL /CE. CUST LIVING W/  
SOME NOISE. (5MIN) MIKEB

FILE

DISTR AB-E01#2

MAGNETIC PERIPHERALS INC.  
a subsidiary of  
CONTROL DATA CORPORATION

# ENGINEERING CHANGE ORDER

DIV \_\_\_\_\_ ECO NUMBER 33982 REV A  
PL \_\_\_\_\_  
DATE APPROVED? JUN 29  
PAGE 1 OF 8

OLD EQUIPMENT IDENTIFICATION NUMBER: CUID19443  
NEW EQUIPMENT IDENTIFICATION NUMBER: SAME

CLASS OF CHANGE			
CLASS I	<input type="checkbox"/>	CLASS II	<input checked="" type="checkbox"/>
RECORD CHANGE ONLY			<input type="checkbox"/>
MISCELLANEOUS ITEMS			YES NO
FCO REQUIRED			<input checked="" type="checkbox"/>
PUBLICATIONS AFFECTED	<input checked="" type="checkbox"/>		<input checked="" type="checkbox"/>
SOFTWARE AFFECTED			<input checked="" type="checkbox"/>
EQUIPMENT SPEC AFFECTED			<input checked="" type="checkbox"/>
SPARE PARTS AFFECTED			<input checked="" type="checkbox"/>
SAFETY AFFECTED (UL/CSA)			<input checked="" type="checkbox"/>
TOOLING AFFECTED			<input checked="" type="checkbox"/>
TEST EQUIPMENT			<input checked="" type="checkbox"/>
ARTWORK AFFECTED			<input checked="" type="checkbox"/>
EMC AFFECTED			<input checked="" type="checkbox"/>

CHARGE NUMBER: N/A

MFG EFFECTIVITY: K/E 8226, B/S 8244, F/G 8240.

- PART DISPOSITION CODES
- USE AS IS
  - REWORK
  - RESIDUAL-RETAIN FOR OTHER USES
  - NOT APPLICABLE
  - INCORPORATE PER EFFECTIVITY
  - NO EFFECT-DOCUMENT CHANGE ONLY
  - SCRAP
  - SEE NOTE ON PAGE \_\_\_\_\_
  - INITIAL RELEASE

REASON FOR CHANGE  
IN ORDER TO ALLOW CUSTOMERS TO RETROFIT THE "LD-AIR" OPTION EASIER AND TO ALLEVIATE ANY PROBLEMS AND CONFUSION BECAUSE OF TWO DIFFERENT RELAY CONTROL PWA'S, ONLY ONE NEW RELAY CONTROL WAS DEVELOPED. THE NEW LD-AIR RELAY CONTROL (77713900?) WILL NOW BE POSITIVE QUANTITY ON ALL AIR OPTION KITS. DUE TO THE NEW BOARD DESIGN, A NEW RELAY CONTROL COVER IS BEING DEVELOPED.

- REASON CATEGORY
- DRAFTING ERROR CORRECTION
  - DESIGN ERROR CORRECTION
  - MANUFACTURING REQUESTED CHANGE
  - MARKETING REQUEST CUSTOMER REQUIREMENT
  - PRODUCT IMPROVEMENT-MAINTAINABILITY/RELIABILITY
  - COST IMPROVEMENT-PLANNED PROGRAM & UNPLANNED
  - INITIAL RELEASE
- (2)

INTERCHANGEABILITY CODES  
A NOT INTERCHANGEABLE  
B INTERCHANGEABLE  
C RECORD

DOCUMENTS AFFECTED										PART DISPOSITION						
ITEM No.	ECO PAGE LOC	DOC TYPE	DWG SIZE	PART NUMBER	REVISION		INACTIVE	REPLACED BY	PART DESCRIPTION	INTER-CHANGE ABILITY	NOT IN PROCESS	IN PROCESS			IN STOCK	
					FROM	TO						IN PRODUCTION	AT VENDOR	IN FINISH GOODS	ON HAND	SPARES
1	3	AY	D	77665760/5769	G	H			BASE PWA ASSEMBLY	C	6					6
*	-	-	-	77665760-3	-	H			.. ..	B	5	5	5	5	5	4
2	4/7	ES	A	77700070/DD79	E	F			AIR OPTION KIT	C	6					6
*	-	-	-	77700070-4	-	F			.. ..	B	5	5	5	5	5	4

DESCRIPTION OF CHANGE  
SEE FOLLOWING PAGES.  
NOTE: RELAY CONTROL TEST SPEC. UPDATED BY ECO 33981.

EFFECTIVITY PLAN		
NEC REQ'D	YES <input checked="" type="checkbox"/>	NO <input type="checkbox"/>
NEC No.		
FACILITY		ISSUE WK
REWORK		FG WK
OKLAHOMA CITY		
OKLAHOMA CITY		

\*PART NUMBER LISTED FOR DISPOSITION ONLY  
ORIGINATOR: S. LUCAS  
ENGINEER: DKS 6/21/82  
DATE: 14 JUNE 82

CHANGE REQUEST No. DKHR 28932  
EC ADMINISTRATOR: B. HUGHES  
DATE: 6-22-82

PL 33982 A



# ENGINEERING PARTS LIST

SIZE D	PARTS LIST NUMBER 0077665760-3	SHEET 3 OF 4	REVISION G00
-----------	-----------------------------------	-----------------	-----------------

ITEM NUMBER	PREFIX CODE	IDENTIFICATION NUMBER	SUFFIX CODE	DRAWING TITLES	PRINT DATE 04/21/82		UNIT OF MEASURE
					QUAN-TITY	SPARES CODE	

0090	OC	0075883450-1		WIRE, JUMPER		1	EA
0091	OC	0075883451-9		WIRE, JUMPER		1	EA
0092	OC	0075883452-7		WIRE, JUMPER		1	EA
0093	OB	0075883007-9		VARIATOR ASSEMBLY		1	EA
0095	OB	0075883475-8		GROUND STRAP		1	EA
0096	1A	0010127144-3		SCR FH 10-32X5/16		1	EA
0097	OC	0095694202-3		SPACER		1	EA
0098	OB	<del>00776623278-1</del> 77686490-2		COVER PWA RLY CNTL		1	EA
0099	1A	0051885504-4		STANDOFF, MALE-FEMALE		1	EA
0100	1C	0017901501-1		SCR THD ROLL		6	EA
0102	1C	0091930600-1		CLAMP-CABLE, RIBBON		2	EA
0104	1C	0093749198-3		SCREW-MACH PAN HD		14	EA
0105	1C	0093749200-7		SCREW-MACH PAN HD		14	EA
0106	1C	0053777900-1		NUT & CAPTIVE WASHER		2	EA
0107	1C	0094277401-9		STRAP, CABLE TIE		5	EA
0110	1C	0094343210-4		MOUNT CABLE TIE		5	EA
0111	OC	0075883453-5		WIRE, JUMPER		1	EA
0112	OC	0075882351-2		WIRE, JUMPER		1	EA
0113	OC	0077685805-2		DECK DOWN SNSR ASSY		1	EA
0114	OX	0077669998-5		CMD HARNESS ACCUM 4		1	EA
0115	OX	VARI-CMD		SEE TABLE A ON DWG		1	EA
0116	OX	VARI-CMD		SEE TABLE A ON DWG		1	EA
0117	1A	0075731302-8		ELECTRICAL SYMBOL		1	EA
0118	1A	0077670656-6		LABEL, BLANK PRINTBLE		1	EA
0119	OB	0077665791-8		CHANNEL, RUBBER		1	EA

PL 33982	ECO NUMBER
ECO SHEET NO 3	REV. A

PARTS LIST TITLE BASE PAN ASSY			
-----------------------------------	--	--	--

SIZE D	PARTS LIST NUMBER 0077665760-3	SHEET 3 OF 4	REVISION G00
-----------	-----------------------------------	-----------------	-----------------



# ENGINEERING PARTS LIST

SIZE		PARTS LIST NUMBER		SHEET		REVISION	
A		0077700070-4		1 OF 1		E	
ITEM NUMBER	PREFIX CODE	IDENTIFICATION NUMBER	SUFFIX CODE	DRAWING TITLES	PRINT DATE		UNIT OF MEASURE
					QUANTITY	SPARES CODE	
<del>0001</del>	<del>DK</del>	<del>77680691-8</del>	<del>A</del>	<del>RLY CNTL SPARES KIT</del>	<del>INTCH</del>	<del>K1</del>	<del>EA</del> <b>DELETE</b>
* 0001	DB	77680691-1	A	PWA, RLY CNTL/LD AIR	INTCH	K1	EA
0002	DX	77668539-8	A	LANA	1		EA
1		77713900-7		PWA, RELAY CONTROL	1	K1	EA

ADD ↗

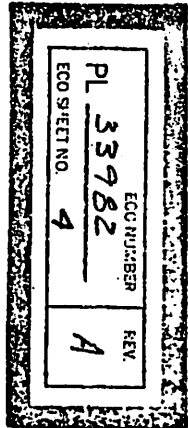

PARTS LIST TITLE							
AIR OPTION KIT #1							
SIZE		PARTS LIST NUMBER		SHEET		REVISION	
A		0077700070-4		1 OF 1		E	

# ENGINEERING PARTS LIST

ITEM NUMBER	PREFIX CODE	IDENTIFICATION NUMBER	SUFFIX CODE	DRAWING TITLES	PRINT DATE		UNIT OF MEASURE
					QUANTITY	SPARES CODE	
<del>0001</del>	<del>AX</del>	<del>77682831-5</del>	<del>A</del>	<del>REL ENTL SPARES KIT</del>	<del>1</del>	<del>KI</del>	<del>EA</del>
* <del>0001</del>	<del>OD</del>	<del>77680651-5</del>	<del>A</del>	<del>PWA RLY ENTL/NO AIR</del>	<del>1</del>	<del>KI</del>	<del>EA</del>
0002	OX	7768536-4	A	NO AIR-96-MB	1		EA
1		77713900-7		PWA RELAY CONTROL	1	KI	EA
1		77680691-1		PWA RELAY CONTR. LD/AIR	1	INTCH	EA

ADD ↗

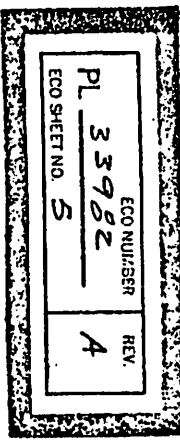

PARTS LIST TITLE			
AIR OPTION KIT #2			
SIZE	PARTS LIST NUMBER	SHEET	REVISION
A	0077700071-2	1 OF 1	E

# ENGINEERING PARTS LIST

SIZE		PARTS LIST NUMBER		SHEET		REVISION	
A		0077700072-0		1 OF 1		E	
ITEM NUMBER	PREFIX CODE	IDENTIFICATION NUMBER	SUFFIX CODE	DRAWING TITLES	PRINT DATE		UNIT OF MEASURE
					QUANTITY	SPARES CODE	
0001	OX	77680691-3	A	RLY CNTL SPARES KIT	INTCH	K1	EA
* 0001	OB	77680691-1	A	PWA, RLY CNTL/LO AIR	1	K1	EA
0002	OX	77668536-4	A	NO AIR-96-MB	1		EA
1		77713ADD-7		PWA, RELAY CONTROL	1	K1	EA

*DELETE*

*ADD ↘*

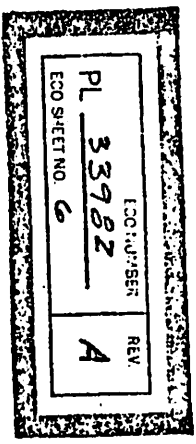

PARTS LIST TITLE			
AIR OPTION KIT #3			
SIZE	PARTS LIST NUMBER	SHEET	REVISION
A	0077700072-0	1 OF 1	E

QTY SPC

1	OD	77638750-8	A PWA RC ADAPTER	1	EA
2	OB	77646535-3	P CLIP	2	EA
3	1A	10127113-8	P SCR PAN HD 6-32X3/8	2	EA
4	1A	10125803-6	P WASHER LOCK #6	2	EA
5	OC	77653889-4	A RLY CNTL JMPR	1	EA
6	1A	51870302-0	P CONN HSING SINGL ROW	1	EA
7	OC	95694206-4	P SPACER	2	EA
⑧	<del>OB</del>	<del>77633553-7</del>	<del>A PWA, RLY CNTL/NG ATR</del>	<del>1</del>	<del>EA</del>
9	OC	77644690-8	A JUMPER PLUG ASSY	1	EA
10	OA	77711013-1	D SPD-CMD RELAY SC4	1	EA
11	OA	77680988-1	D INSTL INSTRUCTIONS	1	EA
⑫	OB	<del>77633358-1</del>	P COVER PWA RLY CNTL	1	EA
13	1A	51885504-4	P STANDOFF, MALE-FEMALE	1	EA
14	OD	75888159-3	A BRACKET-RELAY CONTR	1	EA

*DELETE*

*B 77680691-1 PWA, RELAY CNTL/LD AIR INTCH*  
*B 77713900-7 PWA RELAY CONTRDL 1*

*ADD*

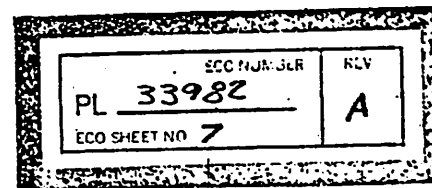

RELAY CNTL ADPTR KIT

	QTY	SPC	
1 OD 77638750-8 A PWA RC ADAPTER	1		EA
2 OB 77646535-3 P CLIP	2		EA
3 1A 10127113-8 P SCR PAN HD 6-32X3/8	2		EA
4 1A 10125803-6 P WASHER LOCK #6	2		EA
5 OC 77653889-4 A RLY CNTL JMPR	1		EA
6 1A 51870302-0 P CONN HSING SINGL ROW	1		EA
7 OC 95694206-4 P SPACER	2		EA
<del>8 OD 77689559-7 A PWA, RLY CNTL/NO AIR</del>	<del>1</del>		<del>EA</del>
9 OC 77644691-6 P JUMPER PLUG ASSY	1		EA
10 OA 77711013-1 D SPD-CMD RELAY SC4	1		EA
11 OA 77680988-1 D INSTL INSTRUCTIONS	1		EA
12 OB <del>77633338-4</del> <sup>77686490-2</sup> P COVER PWA RLY CNTL	1		EA
13 1A 51885504-4 P STANDOFF, MALE-FEMALE	1		EA
14 OD 75888159-3 A BRACKET-RELAY CONTR	1		EA

*DELETE*

*8 77713900-7 PWA RELAY CONTRL 1*  
*8 77680691-1 PWA RELAY CNTL/LO AIR INTCH*

*ADD*

ECO NUMBER	REV
PL <u>35982</u>	A
ECO SHEET NO <u>SF</u>	

RELAY CNTL ADPTR KIT

FILE

DISTR AS-ED1#2

# MAGNETIC PERIPHERALS INC.

# ENGINEERING CHANGE ORDER

DIV **PL** ECO NUMBER **33982** REV **B A**  
 PAGE 1 OF 3

GD A subsidiary of  
CONTR. DATA CORPORATION

DATE APPROVED **27 JUN 82**

OLD EQUIPMENT IDENTIFICATION NUMBER **CUD19448**  
 NEW EQUIPMENT IDENTIFICATION NUMBER **SAME**

CLASS OF CHANGE	
CLASS I	<input type="checkbox"/>
CLASS II	<input checked="" type="checkbox"/>
RECORD CHANGE ONLY	
MISCELLANEOUS ITEMS	YES NO
FCO REQUIRED	<input type="checkbox"/> <input checked="" type="checkbox"/>
PUBLICATIONS AFFECTED	<input checked="" type="checkbox"/> <input type="checkbox"/>
SOFTWARE AFFECTED	<input type="checkbox"/> <input checked="" type="checkbox"/>
EQUIPMENT SPEC AFFECTED	<input type="checkbox"/> <input checked="" type="checkbox"/>
SPARE PARTS AFFECTED	<input type="checkbox"/> <input checked="" type="checkbox"/>
SAFETY AFFECTED (UL/CSA)	<input type="checkbox"/> <input checked="" type="checkbox"/>
TOOLING AFFECTED	<input type="checkbox"/> <input checked="" type="checkbox"/>
TEST EQUIPMENT	<input type="checkbox"/> <input checked="" type="checkbox"/>
ARTWORK AFFECTED	<input type="checkbox"/> <input checked="" type="checkbox"/>
EMC AFFECTED	<input type="checkbox"/> <input checked="" type="checkbox"/>

CHARGE NUMBER  
**N/A**

MFG EFFECTIVITY **77700071-K/S 8233, B/S 8235, F/G 8237** **B**  
**K/S 8226, B/S 8244, F/G 8246.**

- PART DISPOSITION CODES**
- USE AS IS
  - REWORK
  - RESIDUAL-RETAIN FOR OTHER USES
  - NOT APPLICABLE
  - INCORPORATE PER EFFECTIVITY
  - NO EFFECT-DOCUMENT CHANGE ONLY
  - SCRAP
  - SEE NOTE ON PAGE \_\_\_\_\_
  - INITIAL RELEASE

**REASON FOR CHANGE**

IN ORDER TO ALLOW CUSTOMERS TO RETROFIT THE "LD-AIR" OPTION EASIER AND TO ALLEVIATE ANY PROBLEMS AND CONFUSION BECAUSE OF TWO DIFFERENT RELAY CONTROL PWA'S, ONLY ONE NEW RELAY CONTROL WAS DEVELOPED. THE NEW LD-AIR RELAY CONTROL (77713900-7) WILL NOW BE POSITIVE QUANTITY ON ALL AIR OPTION KITS. DUE TO THE NEW BOARD DESIGN, A NEW RELAY CONTROL COVER IS BEING DEVELOPED.

- REASON CATEGORY**
- DRAFTING ERROR CORRECTION
  - DESIGN ERROR CORRECTION
  - MANUFACTURING REQUESTED CHANGE
  - MARKETING REQUEST CUSTOMER REQUIREMENT
  - PRODUCT IMPROVEMENT-MAINTAINABILITY/RELIABILITY
  - COST IMPROVEMENT-PLANNED PROGRAM & UNPLANNED
  - INITIAL RELEASE
- 2**

- INTERCHANGEABILITY CODES**
- NOT INTERCHANGEABLE
  - INTERCHANGEABLE
  - RECORD

DOCUMENTS AFFECTED										PART DISPOSITION						
ITEM No.	ECO PAGE LOC	DOC TYPE	DWG SIZE	PART NUMBER	REVISION		INACTIVE	REPLACED BY	PART DESCRIPTION	INTER-CHANGE ABILITY	NOT IN PROCESS	IN STOCK				
					FROM	TO						IN PRO-DUCTION	AT VENDOR	IN FINISH GOODS	ON HAND	SPARES
1	3	AY	D	77665760/5769	G	H			BASE PAN ASSEMBLY	C	6					5
*	-	-	-	77665760-3	-	H			.. ..	B	5	5	5	5	5	4
2	4/7	ES	A	77700070/DD79	E	F			AIR OPTION KIT	C	6					6
*	-	-	-	77700070-4	-	F			.. ..	B	5	5	5	5	5	4

**DESCRIPTION OF CHANGE**

SEE FOLLOWING PAGES.

NOTE: RELAY CONTROL TEST SPEC. UPDATED BY ELO 33981.

\*PART NUMBER LISTED FOR DISPOSITION ONLY

**EFFECTIVITY PLAN**

NEC REQ'D YES  NO  NEC No. \_\_\_\_\_

REWORK	FACILITY	ISSUE WK	FG WK
	OKLAHOMA CITY		
AUTO	FACILITY	ISSUE WK	FG WK
	OKLAHOMA CITY		

PL 33982

ORIGINATOR **S. LUCAS**  
 DATE **14 JUNE 82**

ENGINEER **DKS 6/21/82**  
 DATE **6/21/82**

CHANGE REQUEST No. **OKHR 22842 B**  
**OKHR 22932**

EC ADMINISTRATOR **BULLWILE FOR D. HUGHES**  
 DATE **6-22-82**

PL 33982  
1A B

----- Reply -----

From: Jack L Haley  
Subject: Pheonix Fixed Modules

Jack - Please see attached trip report for current status on Mag Data. As Barry Fish has informed you, our next step is to review Xidex's repair procedure, as this too, is a repair source for fixed modules.

I realize the Field time and frustration involved with this quality problem however, I think you'll agree, I cannot "alert" the Field to a problem until I have facts to report. Since Barry's return from Mag Data, 2/18, we have initiated a purge notice and are in the process of publishing a TSB denoting the exact s/n's of modules that are defective.

Last Friday, Barry rejected most of the inventory in Tewksbury but can assist you in obtaining a good module if you still have a down situation (I couldn't find a TAC call). As with most purges, stock will be available on a limited basis until the vendor can rework defective stock. If Xidex is experiencing similar problems, another purge notice/TSB will be generated. Kim

----- Original Memo -----

Kim:

As you may already be aware of the field is experiencing severe problems with the replacement fixed modules from stock. A recent incident in Conn. where 5 modules had to be tried to obtain one which barely was within spec (servo adj) and now, per the attached memo, where we are on the sixth module and no progress. Barry Fish has been aware of these problems, but the situation continues to deteriorate. What is the action plan to deal with this problem, I would like a call tomorrow defining the solution and an alert to the field so that many hundreds of manhours are not wasted trying trying to fix problems that cannot be fixed.

Jack Haley  
Rtom NE Region

REGARDING THE PHOENIX FIXED MEDIA PROBLEM. THE RANGE OF SERIAL #'S FOR THE MAGNETIC DATA INC. FIXED MEDIA THAT IS CAUSING PROBLEMS IS THE FOLLOWING:

\*  
MA532287 TO MA569208

\*  
I WAS INFORMED THAT THE OTHER VENDOR, XIDEX, IS OF QUESTIONABLE RELIABILITY BUT ACCORDING TO PRODUCT SUPPORT, LESS OF A RISK. I HAVE A TAC CALL OPEN NOW WHERE A CE HAS TRIED 2 FIXED MODULES AND IS EXPERIENCING SIMILAR PROBLEMS AS MAGNETIC DATA. I BELIEVE THESE ARE XIDEX PACKS BUT NOT SURE. THE SERIAL #'S THE CE HAD WERE X00009536 AND X00009540. I AM MAKING AN ASSUMPTION THAT THE "X" REPRESENTS XIDEX. IF ANYONE CAN VERIFY THIS, LET US KNOW.

\*  
MAGNETIC DATA MEDIA HAS BEEN PURGED AND GOOD MEDIA SHOULD BE AVAILABLE ACCORDING TO PRODUCT SUPPORT.

BILL C

MAGNETIC PERIPHERALS INC.

CD a subsidiary of CONTROL DATA CORPORATION

ENGINEERING CHANGE ORDER

DIV PL 33874 A ECO NUMBER 33874 A REV PAGE 1 OF 15

DATE APPROVED 32 MAR 1982

OLD EQUIPMENT IDENTIFICATION NUMBER CMD/9448

NEW EQUIPMENT IDENTIFICATION NUMBER SAME

Table with columns: CLASS OF CHANGE, RECORD CHANGE ONLY, MISCELLANEOUS ITEMS, YES, NO. Rows include ECO REQUIRED, PUBLICATIONS AFFECTED, SOFTWARE AFFECTED, EQUIPMENT SPEC AFFECTED, SPARE PARTS AFFECTED, SAFETY AFFECTED (UL/CSA), TOOLING AFFECTED, TEST EQUIPMENT, ARTWORK AFFECTED, EMC AFFECTED.

CHARGE NUMBER 867524

MFG EFFECTIVITY B/S 8223 FIG 8225

- PART DISPOSITION CODES: 1. USE AS IS, 2. REWORK, 3. RESIDUAL-RETAIN FOR OTHER USES, 4. NOT APPLICABLE, 5. INCORPORATE PER EFFECTIVITY, 6. NO EFFECT-DOCUMENT CHANGE ONLY, 7. SCRAP, 8. SEE NOTE ON PAGE 1, 9. INITIAL RELEASE.

REASON FOR CHANGE THE RETRACT VELOCITY MAY BE EXCEEDED DUE TO THE LOSS OF LOGIC CONTROL ON K2 (SERVO RELAY) WHEN THE HEADS ARE LOADED ON A HIGH CYLINDER AND THE POWER IS INTERRUPTED.

- REASON CATEGORY: 1. DRAFTING ERROR CORRECTION, 2. DESIGN ERROR CORRECTION, 3. MANUFACTURING REQUESTED CHANGE, 4. MARKETING REQUEST CUSTOMER REQUIREMENT, 5. PRODUCT IMPROVEMENT-MAINTAINABILITY/RELIABILITY, 6. COST IMPROVEMENT-PLANNED PROGRAM & UNPLANNED, 7. INITIAL RELEASE.

7

INTERCHANGEABILITY CODES: A NOT INTERCHANGEABLE, B INTERCHANGEABLE, C RECORD

Table with columns: ITEM No., ECO PAGE LOC, DCC TYPE, DWG SIZE, PART NUMBER, REVISION (FROM, TO), INACTIVE, REPLACED BY, PART DESCRIPTION, INTER-CHANGE ABILITY, NOT IN PROCESS, IN PROCESS (IN PRODUCTION, AT VENDOR, IN FINISH GOODS, ON HAND, SPARES).

DESCRIPTION OF CHANGE SEE BODY OF THIS ECO POSSIBLE CREATION OF 77680651 FROM 77680650; 77680661 FROM 77680660 AND 77680691 FROM 77680690. NOTE: THIS ECO AUTHORIZES REWORK OF A MAXIMUM OF 4500 PWA'S LISTED IN THIS ECO LOCATED AT MPI OKL.

EFFECTIVITY PLAN table with columns: FACILITY, ISSUE WK, FG WK, REWORK, AUTO. Includes OKLAHOMA CITY entries.

ORIGINATOR: [Signature] DATE 5-18-82 ENGINEER: Joe Lubec DATE 3/17/82

CHANGE REQUEST No. OKHR 28564

EC ADMINISTRATOR: [Signature] DATE 3/17/82

PL 33874 A





MAGNETIC PERIPHERALS INC.

 a subsidiary of  
CONTROL DATA CORPORATION

ECO-FCO

DIV	FCO NUMBER	REV
PL	33874	A
PAGE 3		

DOCUMENTS AFFECTED

PART DISPOSITION

ITEM No.	ECO PAGE LOC	DOC. TYPE	DWG SIZE	PART NUMBER	REVISION		INACTIVE	REPLACED BY	PART DESCRIPTION	INTER-CHANGEABILITY	NOT IN PROCESS	PART DISPOSITION				
					FROM	TO						IN PRODUCTION	AT VENDOR	IN FINISH GOODS	ON HAND	SPARES

ITEMS 1, 3 & 6:

INACTIVATE

ITEM 2:

CREATE 77680651 SAME AS 77680650 EXCEPT:  
PL SAME EXCEPT:

ACTION	ITEM	NUMBER	DESCRIPTION	FROM	TO	U/M
DECREASE	5	15164423-4	I.C. 75472	3	2	EA
ADD	42	77713200-2	PWA, RELAY PIGGYBACK	0	1	EA

SH. 1: UPDATE TO AGREE WITH PAGE 6 OF THIS ECO.

ITEM 4:

SH. 1: UPDATE TO AGREE WITH PAGE 7 OF THIS ECO.

SH. 2: UPDATE TO AGREE WITH PAGE 8 OF THIS ECO.

MAGNETIC PERIPHERALS INC.

GD a subsidiary of CONTROL DATA CORPORATION

ECO-FCO

DIV | FCO NUMBER | REV  
 PL 33874 A  
 PAGE 4

DOCUMENTS AFFECTED										PART DISPOSITION						
ITEM No.	ECO PAGE LOC	DOC. TYPE	DWG SIZE	PART NUMBER	REVISION		INACTIVE	REPLACED BY	PART DESCRIPTION	INTER-CHANGE ABILITY	NOT IN PROCESS	IN PROCESS			IN STOCK	
					FROM	TO						IN PRODUCTION	AT VENDOR	IN FINISH GOODS	ON HAND	SPARES

ITEM 5:

- SH. 2: UPDATE TO AGREE WITH PAGE 9 OF THIS ECO.
- SH. 3: UPDATE TO AGREE WITH PAGE 10 OF THIS ECO.
- SH. 4: UPDATE TO AGREE WITH PAGE 11 OF THIS ECO.
- SH. 9: UPDATE TO AGREE WITH PAGE 12 OF THIS ECO.
- ADD SH. 9.1 AS SHOWN ON PAGE 13 OF THIS ECO.

ITEM 7:

CREATE 77680691 SAME AS 77680690 EXCEPT:  
 PL SAME EXCEPT:

ACTION	ITEM	NUMBER	DESCRIPTION	FROM	TO	U/M
DECREASE	5	15164423-4	I.C. 75472	3	2	EA
ADD	50	77713200-2	PWA, RELAY PIGGYBACK	0	1	EA

SH. 1: UPDATE TO AGREE WITH PAGE 14 OF THIS ECO.

MAGNETIC PERIPHERALS INC.

 a subsidiary of  
CONTROL DATA CORPORATION

ECO-FCO

DIV | FCO NUMBER | REV

PL 33874 | A  
PAGE 5

DOCUMENTS AFFECTED

PART DISPOSITION

ITEM No.	ECO PAGE LOC	DOC. TYPE	DWG SIZE	PART NUMBER	REVISION		INACTIVE	REPLACED BY	PART DESCRIPTION	INTER-CHANGE ABILITY	PART DISPOSITION				
					FROM	TO					NOT IN PROCESS	IN PROCESS			IN STOCK
											IN PRODUCTION	AT VENDOR	IN FINISH GOODS	ON HAND	SPARES

ITEM 8:

PL SAME EXCEPT:

ACTION	ITEM	NUMBER	DESCRIPTION	FROM	TO	U/M
ADD	3	77713230-9	T.S. PIGGYBACK	0	X	EA

DOCUMENTS AFFECTED

ITEM No.	ECO PAGE LOC	DOC. TYPE	DWG SIZE	PART NUMBER	REVISION		INACTIVE	REPLACED BY	PART DESCRIPTION	INTER-CHANGE ABILITY	PART DISPOSITION				
					FROM	TO					NOT IN PROCESS	IN PROCESS		IN STOCK	
											IN PRODUCTION	AT VENDOR	IN FINISH GOODS	ON HAND	SPARES

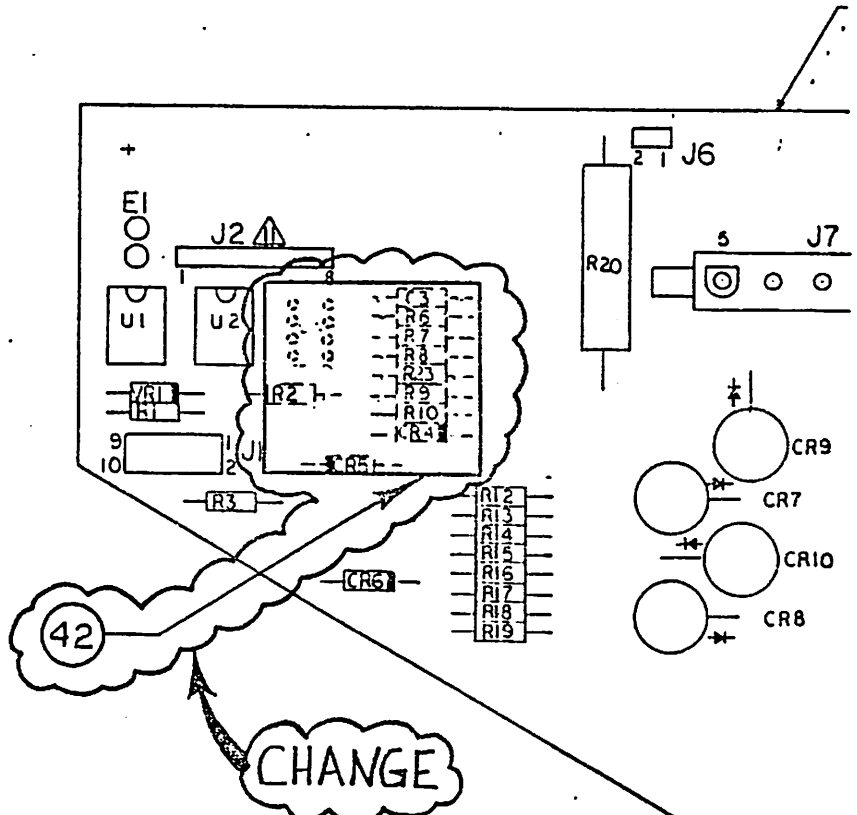

RES	PL ITEM
R1	24
R2	28
R3	24
R4	—
R5	—
R6	24
07	24

SOCKET	PL ITEM
XK1	40
XK2	6

CONN	PL ITEM
J1	22
J2	16
J3	9
J4	10
J5	14
J6	8
J7	13
E1	25

IC	PL ITEM
U1	5
U2	5
U3	5
U4	—
U5	—

CAP	PL ITEM
C1	—
C2	—
C3	21

DOCUMENTS AFFECTED

PART DISPOSITION

ITEM No.	ECO PAGE LOC	DOC. TYPE	DWG SIZE	PART NUMBER	REVISION		INACTIVE	REPLACED BY	PART DESCRIPTION	INTER-CHANGE ABILITY	PART DISPOSITION					
					FROM	TO					NOT IN PROCESS	IN PROCESS			IN STOCK	
											IN PRODUCTION	AT VENDOR	IN FINISH GOODS	ON HAND	SPARES	

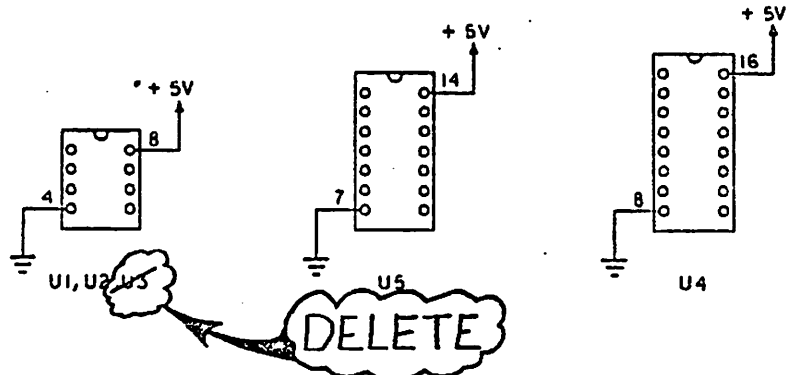
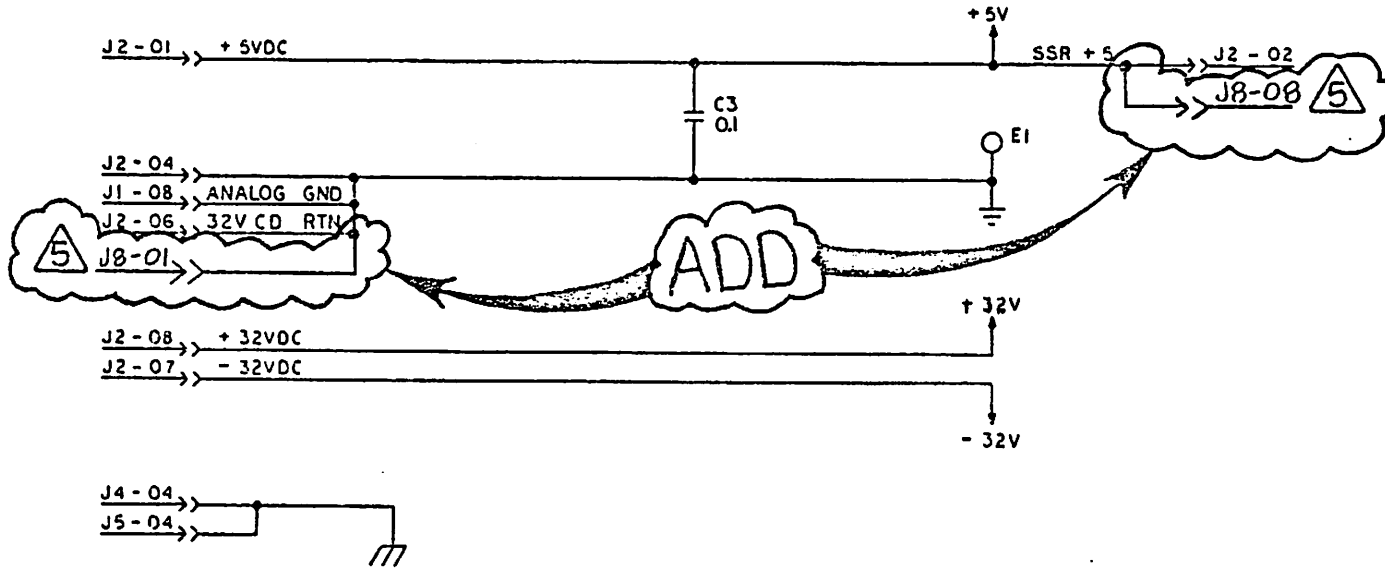

- NOTES: UNLESS OTHERWISE SPECIFIED
1. RESISTOR VALUES ARE IN OHMS, 1/4W, ±5%
  2. CAPACITOR VALUES ARE IN MICROFARADS
  - △3. USED ONLY ON ASSEMBLY 77680690-3
  - △4. CONNECTIONS DEPEND ON RELAY SUPPLIED

△5. J8 CONNECTS TO 77713200 PWA.

ADD



		PC	SPEC. NO.	SHEET	REV.
		A	77680680	2	A

TEST SPECIFICATION FOR RELAY CONTROL PWA

TABLE OF CONTENTS

1.0	Scope .....	3
1.1	Functions .....	3
2.0	Applicable Documents .....	3
3.0	Requirements .....	3
3.1	Test Equipment Required .....	4
3.2	Criteria of Acceptance .....	4
3.3	Static Test and Measurements .....	4
3.4	Power on Test (Non-Operating) .....	5
3.5	Power on Test (Operating) .....	5
	3.5.1 Test #1 .....	5
	3.5.2 Test #2 .....	9
	3.5.3 Test #3 .....	9
	3.5.4 Test #4 (PWA 77680680 ONLY) .....	9
<del>4.0</del>	<del>3.5.5 TEST #5</del> .....	<del>9.1</del>
4.0	Quality Assurance revisions .....	10
5.0	Special Handling Requirements .....	10
6.0	Definitions .....	10

CHANGE

PL 33874	ECO NUMBER	REV.
ECO SHEET NO. 9		A



		PC	SPEC. NO.	SHEET	REV.
		A	77680680	3	A

TEST SPECIFICATION FOR RELAY CONTROL PWA

1.0 SCOPE

This document describes test requirements for RELAY CONTROL Board PWA 77680650 and 77680690.

1.1 FUNCTIONS

1. Switches head actuator power between a servo power amplifier and an emergency retract amplifier in response to logic commands and loss of either (+) 5 VDC or (+32) VDC.
2. Energizes the pack cover unlock solenoid in response to logic commands.
3. Switches control power to a solid state relay in response to logic commands, and a motor thermal overheat interlock.

DELETE

4. Transfers spindle motor power sources between the AC output of a solid state relay and a bridge rectified DC output in response to logic commands.

5. Provides transistor controlled DC power to a mechanical relay in response to logic commands.

- 5β. Flashes fault LED when air pressure is low leaving absolute filter.

2.0 APPLICABLE DOCUMENTS

- Assembly and parts list
- Schematic
- Artwork

- 77680680, 77680690
- 77680660
- 77680670

PL	ECO NUMBER 33874	REV. A
ECO SHEET NO: 10		

CHANGE

CHANGE

3.0 REQUIREMENTS

Requirements for tests of Relay Control Board Assemblies are based on the assumption that all components have been satisfactorily tested prior to PWA Assembly.

CAUTION

Hazardous voltages are present in this PWA when installed in equipment; adequate safety precautions should be observed.

		PC	SPEC NO.	SHEET	REV.
		A	77680680	4	A

TEST SPECIFICATION FOR RELAY CONTROL PWA

3.1 TEST EQUIPMENT REQUIRED

- a. Power Source capable of providing the following: 32.0 volts D.C.  $\pm 3\%$  with a load from zero to 0.32 amperes.
- b. Power Source capable of providing the following: 5.0 VDC  $\pm 2\%$  with a load from zero to 400 milliamperes.
- c. A 60 Hz sinusoidal power source capable of providing the following: 35.0  $\pm 5\%$  volts AC RMS with a load from zero to 3.2 amperes.
- d. Ohmmeter capable of measuring 1.0 ohm to 1.0 megohm  $\pm 2.5\%$  and to 5.0 megohms  $\pm 20\%$ .
- e. 5.0 ohm - 55 Watt - 5% Resistor (Qty. 2)
- f. 150 ohm - 10 Watt - 5% Resistor
- g. 160 ohm - 1/2 Watt - 5% Resistor
- h. Voltmeter capable of measuring 0.30 to 3.00 volts D.C.  $\pm 3\%$  with floating reference.
- i. Voltmeter capable of measuring 0.050 to 35.0 volts D.C.  $\pm 2\%$  with grounded reference and an input impedance 1.0 megohm or greater.
- j. Voltage select plug 1 (connects J7-01 to J7-02, J7-03 to J7-04).
- k. 220 ohm - 1/2 Watt - 5% resistor
- l. 1K ohm - 1/2 Watt - 5% resistor

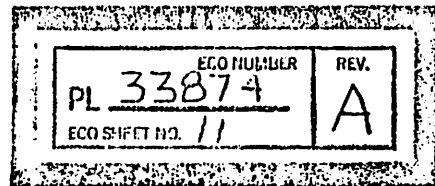

3.2 CRITERIA OF ACCEPTANCE

Each board must satisfactorily meet all requirements set forth in this test specification in order to be considered acceptable. Unacceptable units shall be reworked.

3.3 STATIC TEST AND MEASUREMENTS

Visually inspect the board for missing or broken components, diode polarity, conformance to drawings listed in paragraph 2.0, faulty solder joints, and general workmanship.

ADD:

M. POWER SOURCE CAPABLE OF PROVIDING THE FOLLOWING:  
2.5 VOLTS D.C.  $\pm 2\%$  WITH A LOAD FROM ZERO TO 400  
MILLIAMPERES.

	PC	SPEC. NO.	SHEET	REV.
	A	77680680	9	B

TEST SPECIFICATION FOR RELAY CONTROL PWA

3.5.2 Test #2

With conditions as specified in paragraph 3.5.1 above except all logic inputs are "Lo" (grounded), and the 35.0 volt RMS AC supply connected:

- a. The voltage at J1-07 (Line OFF/+L) shall be 5.0 ±0.25 Volts D.C.
- b. The voltage at Termination "A" with respect to Termination "B" shall be (+) 30.0 ±2.0 Volts D.C.
- c. The specified resistances shall be observed between the following terminations with the polarity indicated:

Less than 1.0 ohm between J3-03 (+) and J3-01 (-)

3.5.3 Test #3

With circuits configured as shown in Figure 1 and all logic inputs "Hi" (Floating), and the 35.0 volt RMS AC supply disconnected:

- a. The voltage at J6-01 (PK-COV-+32) shall be (+)27.5 Volts D.C.
- b. The voltage at J1-07 (Line-OFF/+L) shall be 5.0 ±0.25 Volts D.C.
- c. The specified resistances shall be observed between the following terminations with the polarity indicated:

Less than 1.0 ohm between J3-03 (+) and J3-01 (-)

Greater than 5.0 megohms between J4-02 (+) and J5-02 (-)

**CHANGE** 

3.5.4 Test #4 (PWA 77680680 ONLY)

- a. With the circuits configured as shown in Figure 2, 3, and 4, the voltage at J1-02 shall be 5.0 ±0.25 volts.
- b. With the circuits configured as shown in Figure 5, the voltage at J1-02 shall be as in wave form shown in Figure 6.

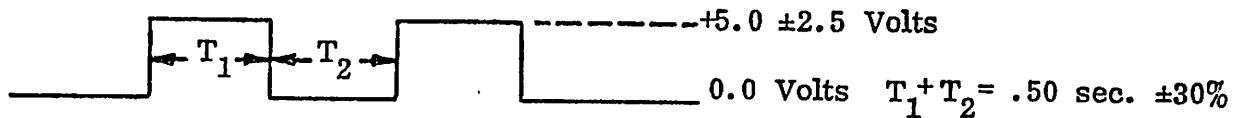

Figure 6. Wave Form at TP 4.

PL <u>33874</u>	ECO NUMBER	REV.
ECO SHEET NO. <u>12</u>		<u>A</u>

ADD THIS PAGE

3, 5, 5 TEST # 5

with circuit configured as shown in Figure 6. and J1-05 (PK-COV-unlock/+L), is "LO" (Grounded with all other Logic inputs "Hi" (Floating), and the 35.0 VOLT Rms AC supply disconnected, the resistance observed between J3-03(+) and J3-01(-) shall be less than ~~1.0~~ 1.0 Ohms.

ECO NUMBER	REV.
PL 33874	A
ECO SHEET NO. 13	

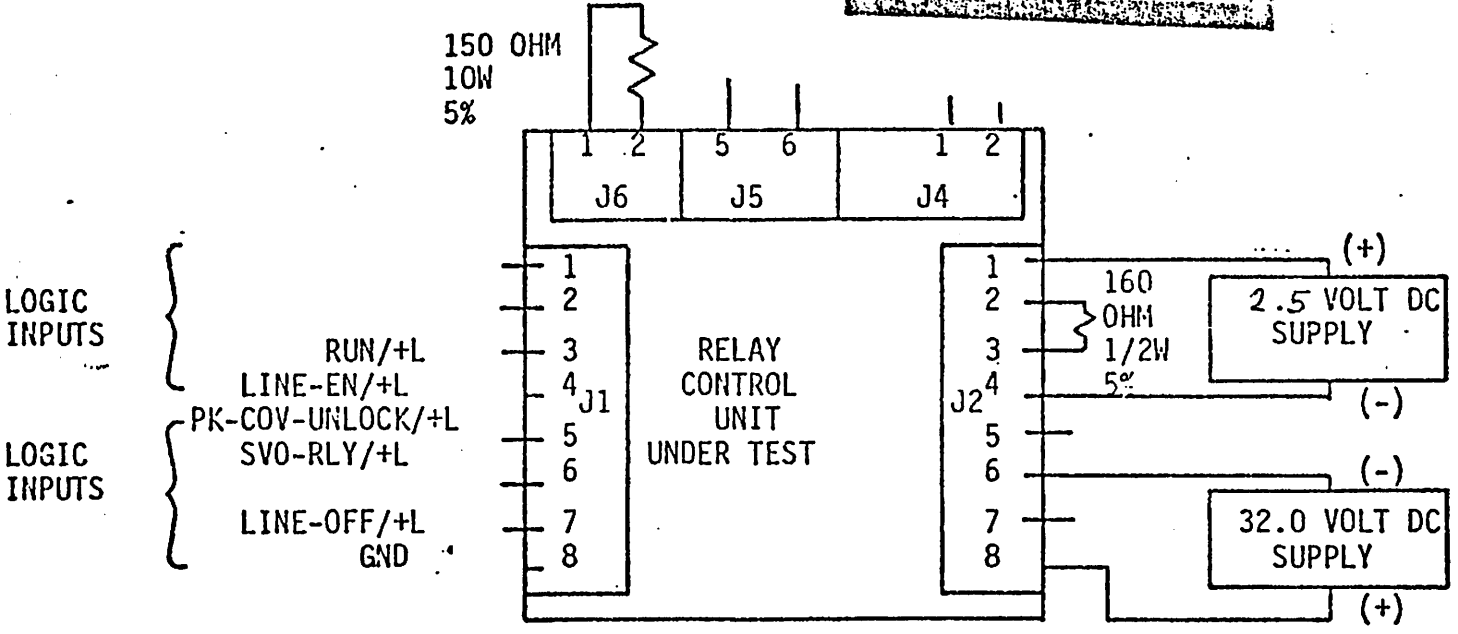

Figure 6.

MAGNETIC PERIPHERALS INC.

GD a subsidiary of CONTROL DATA CORPORATION

ECO-FCO

DIV | FCO NUMBER | REV  
 PL 33874 | A  
 PAGE 14

DOCUMENTS AFFECTED

ITEM No.	ECO PAGE LOC	DOC. TYPE	DWG SIZE	PART NUMBER	REVISION		INACTIVE	REPLACED BY	PART DESCRIPTION
					FROM	TO			

PART DISPOSITION

INTER-CHANGEABILITY	NOT IN PROCESS	IN PROCESS			IN STOCK	
		IN PRODUCTION	AT VENDOR	IN FINISH GOODS	ON HAND	SPARES

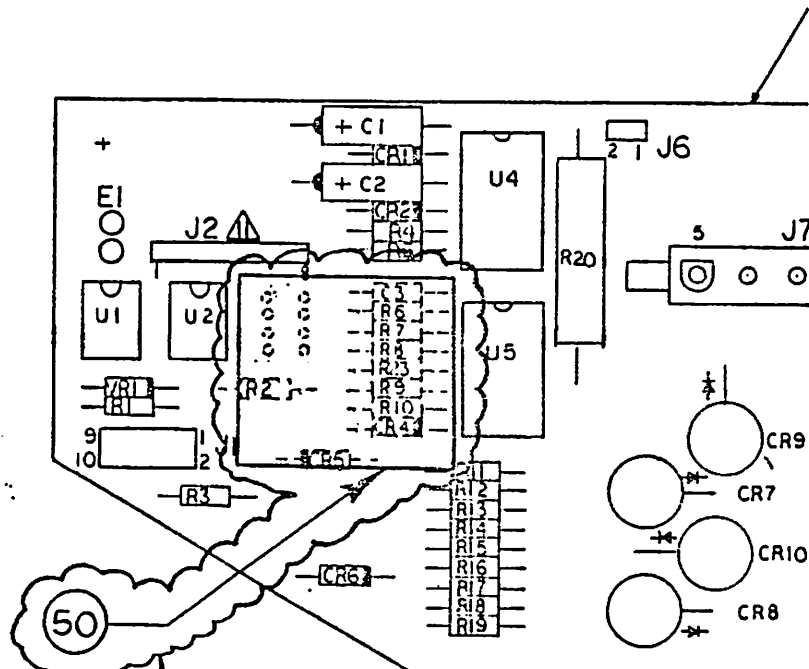

CHANGE

CHANGE

RES	PL ITEM
R1	24
R2	28
R3	24
R4	45
R5	44
R6	24
R7	24

SOCKET	PL ITEM
XK1	40
XK2	6

CONN	PL ITEM
J1	22
J2	16
J3	9
J4	10
J5	14
J6	8
J7	13
E1	25

IC	PL ITEM
U1	5
U2	5
U3	5
U4	43
U5	42

CAP	PL ITEM
C1	47
C2	46
C3	21



MAGNETIC PERIPHERALS INC.

 a subsidiary of  
CONTROL DATA CORPORATION

ECO-FCO

DIV	FCO NUMBER	REV
	PL 33874	A
PAGE 15F		

DOCUMENTS AFFECTED

PART DISPOSITION

ITEM No.	ECO PAGE LOC	DOC. TYPE	DWG SIZE	PART NUMBER	REVISION			REPLACED BY	PART DESCRIPTION	INTER-CHANGE ABILITY	PART DISPOSITION				
					FROM	TO	INACTIVE				IN PROCESS		IN STOCK		
										IN PRODUCTION	AT VENDOR	IN FINISH GOODS	ON HAND	SPARES	

REWORK INSTRUCTIONS

CREATE ASSEMBLIES: 77680651 REV E FROM 77680650  
77680691 REV E FROM 77680690

REPLACE U3 (15164423-4 I.C. 75A72)  
WITH 77713200-2 (PWA RELAY PIGGYBACK)

MAGNETIC PERIPHERALS INC.

 a subsidiary of CONTROL DATA CORPORATION

**ENGINEERING CHANGE ORDER**

DATE APPROVED *82 MAR 19*

DISTR **A8-E05**

DIV **PL** ECO NUMBER **33874** REV **B**  
PAGE 1 OF 15

REV 585 1-3-81 12-00-81 4-20-82

PL 33874 B

PL 33874 B

OLD EQUIPMENT IDENTIFICATION NUMBER **CMD/9448**  
NEW EQUIPMENT IDENTIFICATION NUMBER **SAME**

CLASS OF CHANGE		YES	NO
CLASS I	<input type="checkbox"/>		
CLASS II	<input checked="" type="checkbox"/>		
RECORD CHANGE ONLY			
MISCELLANEOUS ITEMS			
FCO REQUIRED			<input checked="" type="checkbox"/>
PUBLICATIONS AFFECTED	<input checked="" type="checkbox"/>		
SOFTWARE AFFECTED			<input checked="" type="checkbox"/>
EQUIPMENT SPEC AFFECTED			<input checked="" type="checkbox"/>
SPARE PARTS AFFECTED	<input checked="" type="checkbox"/>		
SAFETY AFFECTED (UL/CSA)			<input checked="" type="checkbox"/>
TOOLING AFFECTED			<input checked="" type="checkbox"/>
TEST EQUIPMENT			<input checked="" type="checkbox"/>
ARTWORK AFFECTED			<input checked="" type="checkbox"/>
EMC AFFECTED			<input checked="" type="checkbox"/>

CHARGE NUMBER **867524**

MFG EFFECTIVITY  
**B/S 8223 FIG 8225**

- PART DISPOSITION CODES**
- USE AS IS
  - REWORK
  - RESIDUAL - RETAIN FOR OTHER USES
  - NOT APPLICABLE
  - INCORPORATE PER EFFECTIVITY
  - NO EFFECT - DOCUMENT CHANGE ONLY
  - SCRAP
  - SEE NOTE ON PAGE **L**
  - INITIAL RELEASE

REASON FOR CHANGE  
**THE RETRACT VELOCITY MAY BE EXCEEDED DUE TO THE LOSS OF LOGIC CONTROL ON K2 (SERVO RELAY) WHEN THE HEADS ARE LOADED ON A HIGH CYLINDER AND THE POWER IS INTERRUPTED.**

- REASON CATEGORY**
- DRAFTING ERROR CORRECTION
  - DESIGN ERROR CORRECTION
  - MANUFACTURING REQUESTED CHANGE
  - MARKETING REQUEST CUSTOMER REQUIREMENT
  - PRODUCT IMPROVEMENT-MAINTAINABILITY/RELIABILITY
  - COST IMPROVEMENT-PLANNED PROGRAM & UNPLANNED
  - INITIAL RELEASE
- 7

**INTERCHANGEABILITY CODES**

A NOT INTERCHANGEABLE  
B INTERCHANGEABLE  
C RECORD

DOCUMENTS AFFECTED											PART DISPOSITION					
ITEM No.	ECO PAGE LOC	DOC TYPE	DWG SIZE	PART NUMBER	REVISION		INACTIVE	REPLACED BY	PART DESCRIPTION	INTER-CHANGE ABILITY	NOT IN PROCESS	IN PROCESS			IN STOCK	
					FROM	TO						IN PRO-DUCTION	AT VENDOR	IN FINISH GOODS	ON HAND	SPARES
1		AY	D	77680650-7	D	E	✓	77680651-5	PWA, RELAY CONTROL/ NO AIR	B	5	2/8	2/8	2/8	2/8	2/8
2		AY	D	77680651-5	-	E			PWA. RELAY CONTROL/ NO AIR	C	9					9
3		SL	D	77680660-6	B	C	✓	77680661-A	SCH, RELAY CONTROL	C	6					6
CONTINUED ON NEXT PAGE																

DESCRIPTION OF CHANGE  
**SEE BODY OF THIS ECO**  
**POSSIBLE CREATION OF 77680651 FROM 77680650; 77680661 FROM 77680660 AND 77680691 FROM 77680690.**

**NOTE: THIS ECO AUTHORIZES REWORK OF A MAXIMUM OF 4500 PWA'S LISTED IN THIS ECO LOCATED AT MPI OKC.**

**EFFECTIVITY PLAN**

NEC REQ'D YES  NO  NEC No.

FACILITY	ISSUE WK	FG WK
REWORK OKLAHOMA CITY		
AUTO OKLAHOMA CITY		

**REV MARKING FOR ASSEMBLED BDS.**

77680651	E
77680691	E

\*PART NUMBER LISTED FOR DISPOSITION ONLY

ORIGINATOR <i>Bill Wilson</i>	ENGINEER <i>Joe Kubicek</i>	DATE <i>3-19-82</i>	DATE <i>3/19/82 CS</i>	CHANGE REQUEST No. <b>OKHR 28564</b>	EC ADMINISTRATOR <i>[Signature]</i>	DATE <i>3/19/82</i>
----------------------------------	--------------------------------	------------------------	---------------------------	---	--	------------------------

DOCUMENTS AFFECTED

PART DISPOSITION

ITEM No.	ECO PAGE LOC	DOC. TYPE	DWG SIZE	PART NUMBER	REVISION		INACTIVE	REPLACED BY	PART DESCRIPTION	INTER-CHANGE ABILITY	NOT IN PROCESS	PART DISPOSITION				
					FROM	TO						IN PROCESS		IN STOCK		

ITEMS 1, 3 & 6:

INACTIVATE

ITEM 2:

CREATE 77680651 SAME AS 77680650 EXCEPT:  
 PL SAME EXCEPT:

	ACTION	ITEM	NUMBER	DESCRIPTION	FROM	TO	U/M
	DECREASE	5	15164423-4	I.C. 75472	3	2	EA
	ADD	42	77713200-2	PWA, RELAY PIGGYBACK	0	1	EA
B	DELETE	1	77680660-6	SCH RELAY CONTROL	X	0	EA
	ADD	1	77680661-4	SCH RELAY CONTROL	0	X	EA
	CHANGE	3	77680680-4	T.S. RELAY CONTRDL	1	X	EA

ITEM 4:

SH:1: UPDATE TO AGREE WITH PAGE 6 OF THIS ECO.

SH. 1: UPDATE TO AGREE WITH PAGE 7 OF THIS ECO.

SH. 2: UPDATE TO AGREE WITH PAGE 8 OF THIS ECO.



DOCUMENTS AFFECTED

PART DISPOSITION

ITEM No.	ECO PAGE LOC	DOC. TYPE	DWG SIZE	PART NUMBER	REVISION		INACTIVE	REPLACED BY	PART DESCRIPTION	INTER-CHANGE ABILITY	PART DISPOSITION				
					FROM	TO					NOT IN PROCESS	IN PROCESS		IN STOCK	
											IN PRODUCTION	AT VENDOR	IN FINISH GOODS	ON HAND	SPARES

ITEM 5:

SH. 2: UPDATE TO AGREE WITH PAGE 9 OF THIS ECO.  
 SH. 3: UPDATE TO AGREE WITH PAGE 10 OF THIS ECO.  
 SH. 4: UPDATE TO AGREE WITH PAGE 11 OF THIS ECO.  
 SH. 9: UPDATE TO AGREE WITH PAGE 12 OF THIS ECO.  
 ADD SH. 9.1 AS SHOWN ON PAGE 13 OF THIS ECO.

ITEM 7:

CREATE 77680691 SAME AS 77680690 EXCEPT:  
 PL SAME EXCEPT:

	ACTION	ITEM	NUMBER	DESCRIPTION	FROM	TO	U/M
	DECREASE	5	15164423-4	I.C. 75472	3	2	EA
	ADD	50	77713200-2	PWA, RELAY PIGGYBACK	0	1	EA
B	DELETE	1	77680660-6	SCH RELAY CONTROL	X	0	EA
	ADD	1	77680661-4	SCH RELAY CONTROL	0	X	EA
	CHANGE	3	77680680-4	T.S. RELAY CONTROL	1	X	EA

SH. 1: UPDATE TO AGREE WITH PAGE 14 OF THIS ECO

DOCUMENTS AFFECTED

PART DISPOSITION

ITEM No.	ECO PAGE LOC	DOC. TYPE	DWG. SIZE	PART NUMBER	REVISION		INACTIVE	REPLACED BY	PART DESCRIPTION	INTER-CHANGEABILITY	PART DISPOSITION				
					FROM	TO					NOT IN PROCESS	IN PROCESS		IN STOCK	
											IN PRODUCTION	AT VENDOR	IN FINISH GOODS	ON HAND	SPARES

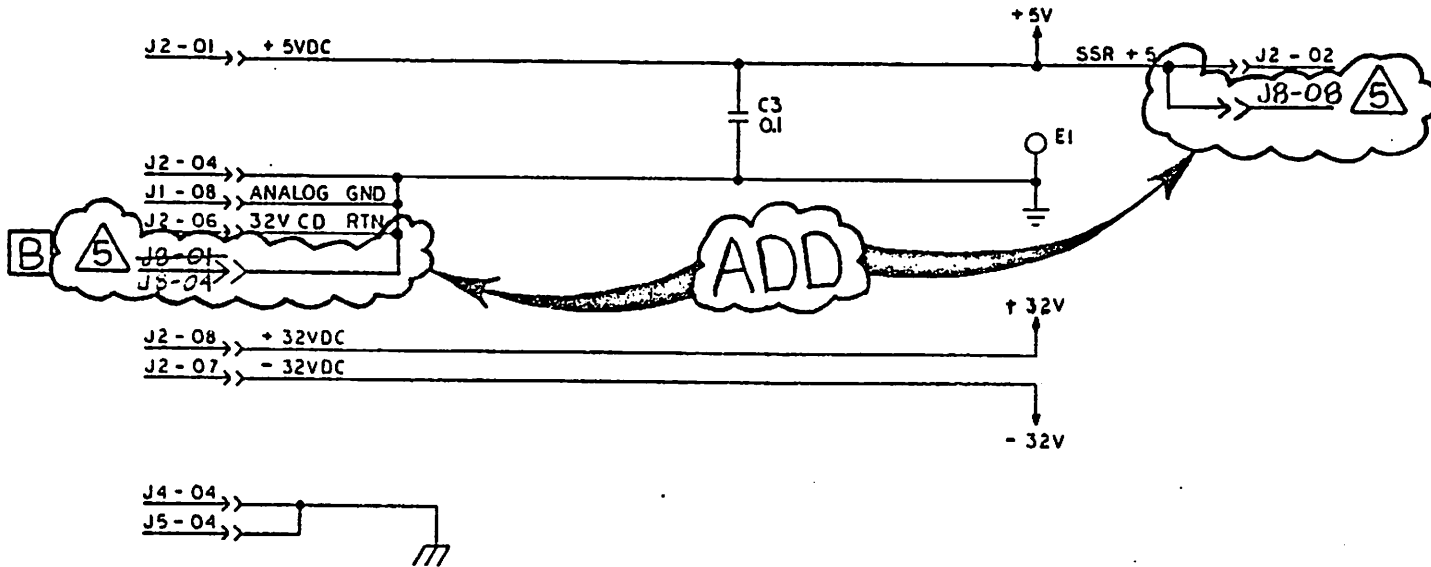

- NOTES: UNLESS OTHERWISE SPECIFIED
1. RESISTOR VALUES ARE IN OHMS, 1/4W, ± 5%
  2. CAPACITOR VALUES ARE IN MICROFARADS
  - △ 3. USED ONLY ON ASSEMBLY 77680690-3
  - △ 4. CONNECTIONS DEPEND ON RELAY SUPPLIED

△ 5. J8 CONNELTS TO 77713200 PWA.

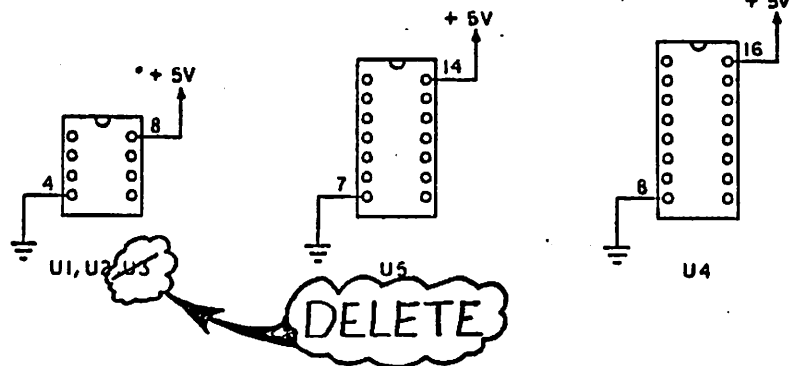

ADD

MAGNETIC PERIPHERALS INC.

GD a subsidiary of CONTROL DATA CORPORATION

ENGINEERING CHANGE ORDER

DATE APPROVED 82 MAR 19

DISTR A8-EO5  
DIV PL 33874 C  
ECO NUMBER 33874 C  
PAGE 1 OF 15

OLD EQUIPMENT IDENTIFICATION NUMBER

CMD/9448

NEW EQUIPMENT IDENTIFICATION NUMBER

SAME

MFG EFFECTIVITY

C 8224  
B/S ~~8223~~ FIG 8225

REASON FOR CHANGE

THE RETRACT VELOCITY MAY BE EXCEEDED DUE TO THE LOSS OF LOGIC CONTROL ON K2 (SERVO RELAY) WHEN THE HEADS ARE LOADED ON A HIGH CYLINDER AND THE POWER IS INTERRUPTED.

CLASS OF CHANGE		
CLASS I	CLASS II	
<input type="checkbox"/>	<input checked="" type="checkbox"/>	
RECORD CHANGE ONLY		
MISCELLANEOUS ITEMS	YES	NO
FCO REQUIRED		<input checked="" type="checkbox"/>
PUBLICATIONS AFFECTED	<input checked="" type="checkbox"/>	
SOFTWARE AFFECTED		<input checked="" type="checkbox"/>
EQUIPMENT SPEC AFFECTED		<input checked="" type="checkbox"/>
SPARE PARTS AFFECTED	<input checked="" type="checkbox"/>	
SAFETY AFFECTED (UL/CSA)		<input checked="" type="checkbox"/>
TOOLING AFFECTED		<input checked="" type="checkbox"/>
TEST EQUIPMENT		<input checked="" type="checkbox"/>
ARTWORK AFFECTED		<input checked="" type="checkbox"/>
EMC AFFECTED		<input checked="" type="checkbox"/>

CHARGE NUMBER

867524

PART DISPOSITION CODES

- USE AS IS
- REWORK
- RESIDUAL-RETAIN FOR OTHER USES
- NOT APPLICABLE
- INCORPORATE PER EFFECTIVITY CHANGE ONLY
- NO EFFECT-DOCUMENT CHANGE ONLY
- SCRAP
- SEE NOTE ON PAGE 1
- INITIAL RELEASE

- REASON CATEGORY
- DRAFTING ERROR CORRECTION
  - DESIGN ERROR CORRECTION
  - MANUFACTURING REQUESTED CHANGE
  - MARKETING REQUEST CUSTOMER REQUIREMENT
  - PRODUCT IMPROVEMENT-MAINTAINABILITY/RELIABILITY
  - COST IMPROVEMENT-PLANNED PROGRAM & UNPLANNED
  - INITIAL RELEASE

7

INTERCHANGEABILITY CODES

- A NOT INTERCHANGEABLE
- B INTERCHANGEABLE
- C RECORD

DOCUMENTS AFFECTED

ITEM No.	ECO PAGE LOC	DOC TYPE	DWG SIZE	PART NUMBER	REVISION		INACTIVE	REPLACED BY	PART DESCRIPTION	INTER-CHANGE ABILITY
					FROM	TO				
1		AY	D	77680650-7	D1	E	✓	77680651-5	PWA, RELAY CONTROL/ NO AIR	B
2		AY	D	77680651-5	-	E			PWA, RELAY CONTROL/ NO AIR	C
3		SL	D	77680660-6	B	C	✓	77680661-4	SCH, RELAY CONTROL	C

PART DISPOSITION

NOT IN PROCESS	IN PROCESS			IN STOCK	
	IN PRODUCTION	AT VENDOR	IN FINISH GOODS	ON HAND	SPARES
5	2/8	2/8	2/8	2/8	2/8
9					9
6					6

CONTINUED ON NEXT PAGE

DESCRIPTION OF CHANGE

SEE BODY OF THIS ECO  
POSSIBLE CREATION OF 77680651 FROM 77680650; 77680661 FROM 77680660 AND 77680691 FROM 77680690.

NOTE: THIS ECO AUTHORIZES REWORK OF A MAXIMUM OF 4500 PWA'S LISTED IN THIS ECO LOCATED AT MPI OKL.

\*PART NUMBER LISTED FOR DISPOSITION ONLY

REV MARKING FOR ASSEMBLED BDS.

77680651	E
77680691	E

EFFECTIVITY PLAN

NEC REQ'D YES  NO  NEC No.

	FACILITY	ISSUE WK	FG WK
REWORK	OKLAHOMA CITY		
AUTO	OKLAHOMA CITY		
	TAMPA		8224

ORIGINATOR

Bill [Signature]

DATE 3-19-82

ENGINEER DKS 3/19/82

Joe [Signature]

DATE 3/19/82 CS

CHANGE REQUEST No.

OKHR 28564

EC ADMINISTRATOR

[Signature]

DATE 3/19/82

PL 33874 C

TAC

INFORMATION CALL

CONTROL NUMBER 06322000

CONTACT NAME LARRY MILLER POSITION CE  
RDB # 3412 TDX # PHONE # 301 296 1663 EXT #

SYSTEM TYPE VS 85 DEVICE TYPE 2280-3  
UTILITY NAME SOFTWARE LEVEL

METHOD OF CALL P T = TELEX, P = PHONE, M = MEMO, E = EMS  
HAS THE AREA OR DISTRICT BEEN CONTACTED  
N A = AREA, D = DISTRICT, B = BOTH, N = NONE  
IS THIS INQUIRY PERTAINING TO A NATIONAL ACCOUNT ?  
U Y = YES, N = NO, U = UNKNOWN

USE THE FOLLOWING AREA TO DESCRIBE THE SITE THAT CREATED THIS REQUEST  
CUST/OFFICE NAME PHONE #  
ADDRESS 3310 CITY STATE  
ON SITE CONTACT NAME

QUESTION (\*) / ANSWER (+)

\*EMP. # 32527.  
\*RE: OLD STYLE IO BOARD ON THE PHOENIX CAUSING PROBLEMS.  
11/18/86: CALLING IN TO DOCUMENT A PROBLEM.  
+A COMPATIBILITY PROBLEM HAS BEEN FOUND W/ CERTAIN VERSIONS  
+OF THE PX I/O BRD WHEN USED W/ CERTAIN SYSTEMS OR WANG DISK  
+CONTROLLERS. IN THIS PARTICULAR CASE A WORKING BP3 PX WAS  
+INSTALLED ON A VS85 AND SOFT ERRORS WERE GENERATED WHENEVER  
+VOLUMES WERE SWITCHED. THE ALIGNMENT OF THE DRIVE WAS  
+CHECKED 3 TIMES & WAS ALWAYS WELL WITHIN SPECS. CAUSE OF  
+THIS PROBLEM WAS THE I/O BRD, CDC # 77616770A. THIS IS AN  
+OLDER STYLE BRD W/ NO SW BANK & BLK CONNECTORS FOR THE A  
+CABLE & TERMINATOR. WHEN THE BRDS WERE 1ST REPLACED FOR  
+THIS PROBLEM A SIMILAR VERSION I/O BRD WAS USED & THE PROB-  
+LEM WAS STILL PRESENT. ANOTHER BP3 PX FROM THE OFFICE WAS  
+BROUGHT IN & USING THIS SAME TYPE I/O BRD ALSO FAILED. THE  
+PROBLEM OCCURRED W/ BOTH A 22V88 & THE 22V28, BUT THESE  
+SAME DRIVES WORKED FINE ON A VS65. ONCE THE CURE WAS FOUND  
+TO BE A NEWER VERSION OF THE I/O BRD W/ THE SW BK, OLDER &  
+NEWER VERSIONS OF THE OTHER CARD CAGE BRDS WERE TESTED BUT  
+NO DIFFERENCE WAS FOUND. THE CDC 77516770A I/O BRD WOULD  
+CAUSE SOFT ERRORS WHEN CHANGING VOLUMES W/ EITHER OLD OR  
+NEW CDC BRDS ON THE VS85 W/ EITHER A 22V28 OR A 22V88.  
+GIVING COPY OF CALL TO DJ.

(30MIN) MIKEB