

WANG

2281W Printer/Plotter User Manual

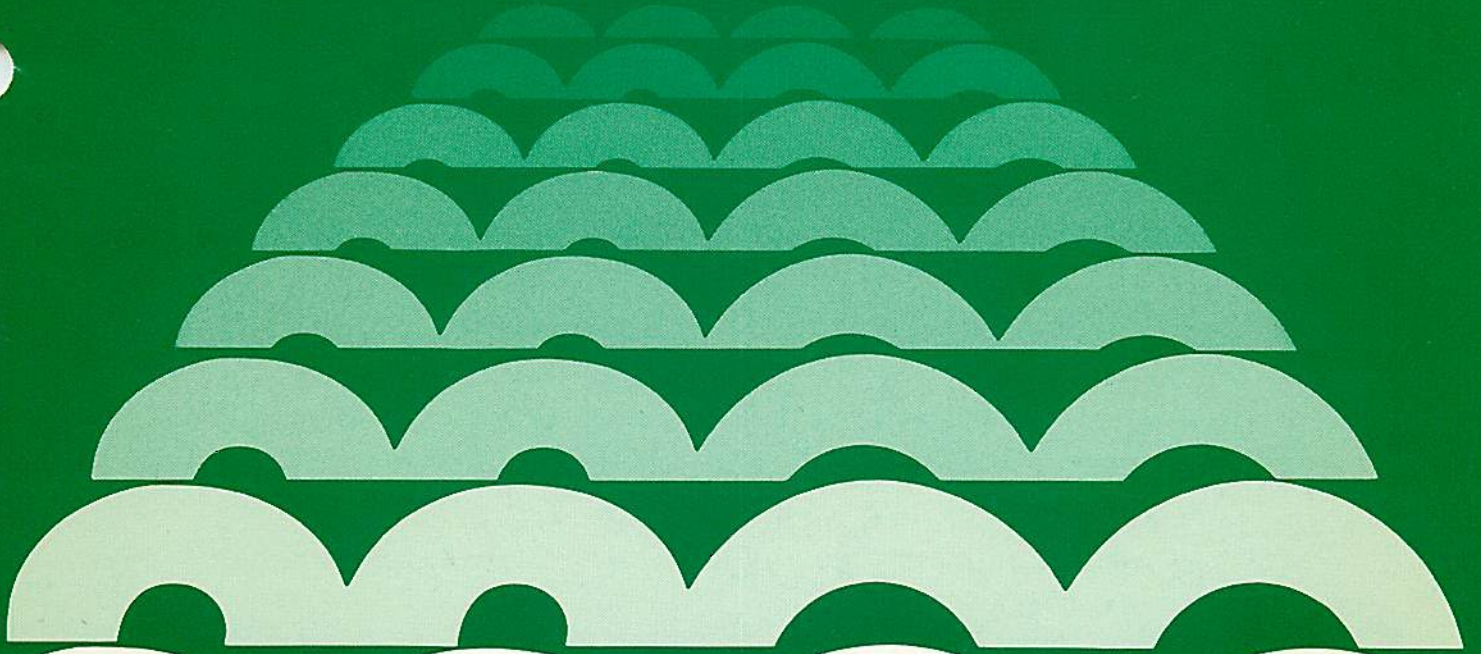

2200



2281 W Printer/Plotter User Manual

© Wang Laboratories Inc., 1979



LABORATORIES, INC.

ONE INDUSTRIAL AVENUE, LOWELL, MASSACHUSETTS 01861. TEL. (617) 469-6000, TWX 710 343-6769, TELEX 84-7421

Disclaimer of Warranties and Limitation of Liabilities

The staff of Wang Laboratories, Inc., has taken due care in preparing this manual; however, nothing contained herein modifies or alters in any way the standard terms and conditions of the Wang purchase agreement, lease agreement, or rental agreement by which this equipment was acquired, nor increases in any way Wang's liability to the customer. In no event shall Wang Laboratories, Inc., or its subsidiaries be liable for incidental or consequential damages in connection with or arising from the use of this manual or any programs contained herein.



LABORATORIES, INC.

ONE INDUSTRIAL AVENUE, LOWELL, MASSACHUSETTS 01851, TEL. (617) 459-5000, TWX 710 343-6769, TELEX 94-7421

HOW TO USE THIS MANUAL

This manual guides the user in the operation of the Model 2281W Printer/Plotter. It is assumed that the user is familiar with the 2200 Wang System and the BASIC language.

For users who are not familiar with the operation of their system, it is recommended that the Programming in BASIC Manual and the Wang BASIC Language Reference Manual (or Wang BASIC-2 Reference Manual) be read before proceeding with this manual.

This manual has been divided into five chapters covering the operational features of the Model 2281W. Chapter 1 contains general user and operator information. Chapter 2 describes device selection and the SELECT statement. Chapters 3 and 4 demonstrate how to generate and format output with the PLOT and PRINT statements. Chapter 5 describes the use of HEX control codes for formatting output. Hexadecimal codes, the printer character set, and specifications are collected in the appendices.

TABLE OF CONTENTS

CHAPTER 1	GENERAL INFORMATION	
1.1	Introduction.	1
1.2	Unpacking and Inspection.	2
1.3	Installation.	2
1.4	Paper Insertion	2
1.5	Ribbon Cartridge Replacement.	3
1.6	Print Wheel Replacement	4
1.7	Fuse Replacement.	6
1.8	Controls and Indicators	6
1.9	Form Alignment.	10
	Manual Form Alignment.	11
	Programmable Form Alignment.	11
	Forms.	12
CHAPTER 2	SELECTING THE MODEL 2281W FOR OUTPUT	
2.1	The SELECT Statement.	13
	Device Type.	14
	Unit Address	16
	Line Length.	16
2.2	SELECT PLOT	19
2.3	SELECT PRINT.	19
2.4	SELECT LIST	21
2.5	SELECT CO (Console Output).	21
2.6	Combining SELECT Parameters	22
2.7	Deselecting the Model 2281W	22
CHAPTER 3	GENERATING OUTPUT WITH THE PLOT STATEMENT	
3.1	The Plot Statement.	23
3.2	Plot Examples	24
CHAPTER 4	FORMATTING OUTPUT WITH THE PRINT STATEMENT	
4.1	PRINT, PRINTUSING, and HEXPRINT Statements	26
	Zone Format.	26
	Packed Format.	27
	PRINTUSING Statement	29
4.2	The Print TAB(); Function	30

CHAPTER 5 FORMATTING OUTPUT WITH HEX CODES

5.1	The HEX Function	32
5.2	Model 2281W Control Codes	32
	Set Left Margin HEX(E8XXXX)	33
	Move(Absolute) HEX(E7XXXXYYYY)	35
	Set Line Feed Spacing HEX(E9YYFF)	37
	Move Incremental Long HEX(E0XXXXYYYY)	41
	Move Incremental Short HEX(E6XXYY)	42
	Set Home HEX(E4)	44
	Processing Continuous Forms	44
	Power On Home HEX(E5)	44
	Backspace HEX(08)	45
	TAB HEX(09)	45
	Line Feed HEX(0A)	46
	Vertical TAB HEX(0B)	46
	Reverse Index HEX(FA)	47
	Top of Form HEX(0C)	47
	Carriage Return HEX(0D)	47
	Clear TAB HEX(19)	48
	Set TAB HEX(1A)	49
	Underscore HEX(5F)	50
	Delete HEX(7F)	50

APPENDICES

Appendix A	Hexadecimal Codes	51
Appendix B	Specifications	52
Appendix C	Decimal/Binary 2's Complement Conversion	54
Appendix D	Trailing Spaces HEX(20) or the HEX(0D) Code in an Alpha Variable	59

PREVENTIVE MAINTENANCE	62
----------------------------------	----

INDEX	63
-----------------	----

LIST OF TABLES

2-1.	Device Types	14
5-1.	Conversion of Physical Distance to Hexadecimal Values Based on 1/60 Inch Increments	34
5-2.	Conversion of Physical Distance to Hexadecimal Values Based on 1/48 Inch Increments	36
5-3.	Conversion of Physical Lines Per Inch Values to Hexadecimal Form	38
5-4.	Conversion of Physical Distance to Hexadecimal Values	43
C-1.	Decimal/Binary/Hexadecimal Conversion	54

LIST OF FIGURES

1-1.	Model 2281W Plotting Output Writer	2
1-2.	Ribbon Cartridge Removal	3
1-3.	Ribbon Cartridge Replacement	4
1-4.	Print Wheel Replacement	5
1-5.	Print Wheel	6
1-6.	The Model 2281W Control Panel	7
1-7.	Platen Levers	10

CHAPTER 1 GENERAL INFORMATION

1.1 INTRODUCTION

This manual describes the characteristics and operations of the Model 2281W Printer/Plotter (refer to Figure 1-1). The Model 2281W is a bidirectional plotting-output writer that uses a daisy character wheel to generate high quality documents and plots. In particular, the Model 2281W has both manual and programmable positioning features for forms filling applications. The printer's console keyboard provides a manual positioning capability in either incremental (1/60 inch (0.0423 cm) horizontally and 1/48 inch (0.0529 cm) vertically) or non-incremental (10- or 12-pitch horizontally and a single line vertically) spacing. Programmable form filling commands allow carriage positioning to an accuracy of 1/60 inch horizontally and 1/48 inch vertically irrespective of the previous carriage position or the lengths of previously typed fields. In addition, the Model 2281W provides a set of programmable commands intended to process preprinted forms which do not conform to the character positioning available on typewriters. An incremental move command allows printed matter to be located at any position on the form to an accuracy of 1/60 inch horizontally and 1/48 inch vertically. A Set Home command, designed for processing continuous forms, provides a simple means of positioning to the top of the next form.

A full line character buffer, which receives data transmitted from the system CPU to the printer, allows speeded throughput (by overlapping CPU and printer operations) and data retention during temporary printer deselection while changing paper, the ribbon, or the print wheel. Output is printed at 30 characters per second with 157 column lines in 12-pitch format or 132 column lines in 10-pitch format.

Discrete or continuous-form paper of widths 3.5 to 15 inches (8.9 to 38 cm) can be used with the Model 2281W. The complete 86-character set for the printer is given in Appendix A.



Figure 1-1. Model 2281W Plotting Output Writer

1.2 UNPACKING AND INSPECTION

The Model 2281W must be unpacked, inspected and installed by a qualified Wang Service Representative. Failure to follow this procedure will void the warranty.

1.3 INSTALLATION

To install your equipment, your Wang Service Representative uses the following procedure.

1. The Printer Controller Board should be installed in the CPU chassis of your system. Its screws should be fully tightened. Note that in the Personal Computer System (PCSII), Disk Work Station, Model 2226, and the Model 2236, the Printer Controller Board is internal to the system.
2. The 36-pin interface connector must be plugged into the Printer Controller Board and its lock clips placed in the up (locked) position.
3. The power cord from the Line Printer must be plugged into a grounded wall outlet (refer to power requirements in Appendix B).

1.4 PAPER INSERTION

Paper is inserted in the Model 2281W using the following procedure.

1. Position the Paper Release Lever, located on the right-hand side, to the rear.
2. Pull the paper bail forward to properly align the paper.

3. Insert the paper down behind the platen and turn the platen knob until the paper comes around and up in front of the platen.
4. Position the Paper Release Lever to its most forward position and align the paper.
5. After the paper is properly positioned, return the paper bail and the Paper Release Lever to their operating positions.
6. Adjust the Copy-Control Lever, on the left, for paper or form thickness adjustments. For single-sheet paper, the lever should be in its most forward position. As paper thickness increases, move the lever toward the rear.
7. Manual vertical fine adjustments of paper can be made by pushing in and rotating the left platen knob.

(Refer to Section 1.9 for Form Alignment Considerations.)

1.5 RIBBON CARTRIDGE REPLACEMENT

The ribbon cartridge can be replaced using the following procedure.

1. Open the front cover by gently pulling up on the front edge of the printer cover.
2. Push the Ribbon Drive Lever (refer to Figure 1-2) to the left until the ribbon cartridge becomes loose.

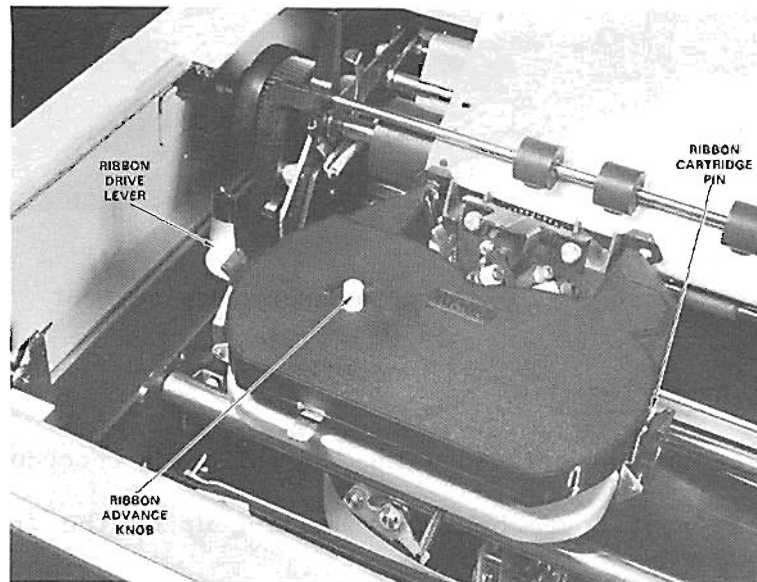

Figure 1-2. Ribbon Cartridge Removal

3. Remove the cartridge by pushing down and releasing the carriage clip, and gently pulling the ribbon out.
4. Rotate the Ribbon Advance Knob on the new cartridge (refer to Figure 1-2) clockwise until the ribbon is taut.
5. To install a new cartridge, slide the exposed portion of the ribbon behind the two ribbon guide posts (refer to Figure 1-3) located in front of the print wheel. Align the right pin of the ribbon cartridge (refer to Figure 1-2) to the right clip on the carriage (refer to Figure 1-3), and push down on the cartridge until it snaps into place. The Ribbon Drive Lever should move back into position.
6. Close the cover.

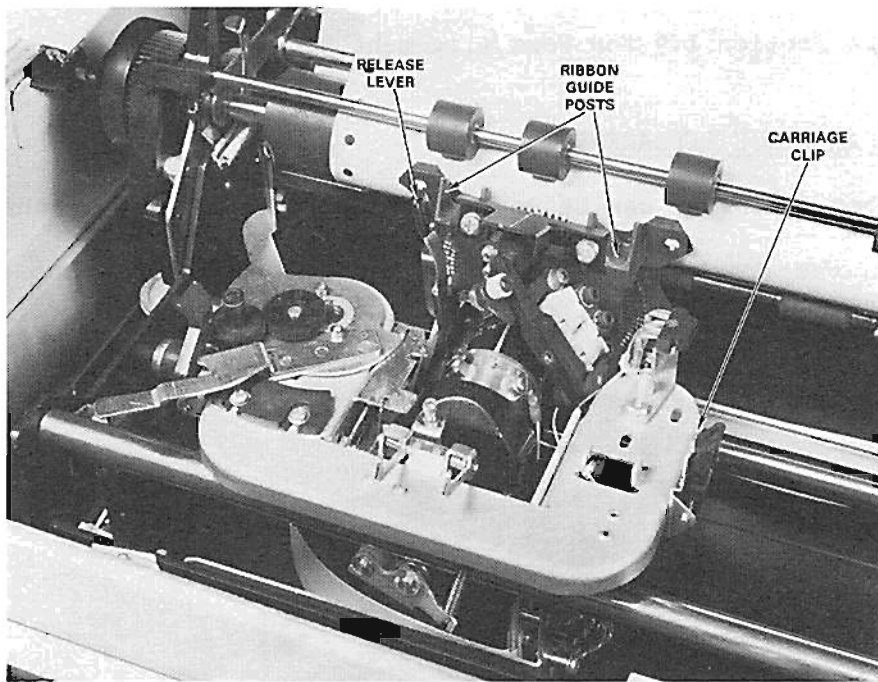

Figure 1-3. Ribbon Cartridge Replacement

1.6 PRINT WHEEL REPLACEMENT

A print wheel can be replaced using the following procedure.

1. Open the front cover by gently pulling up on the front edge of the printer cover.
2. Remove the ribbon cartridge as previously described (Section 1.5).

3. To expose the print wheel, gently pull the Release Lever to the extreme right, back as far as it will go, and to the left until it locks in place (refer to Figures 1-3 and 1-4).

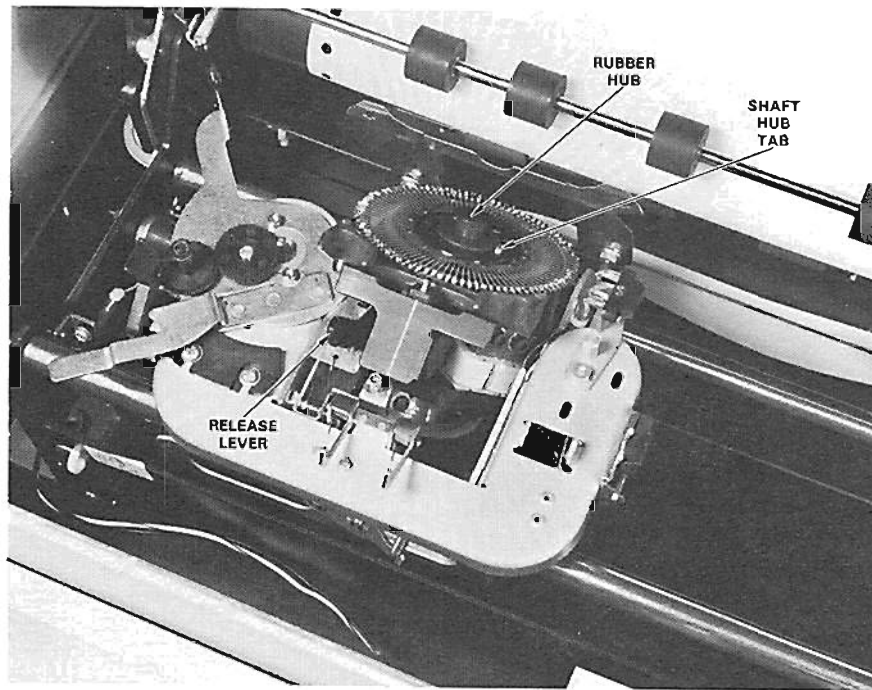

Figure 1-4. Print Wheel Replacement

4. Grasp the rubber hub (Figure 1-4) and gently pull away the print wheel.
5. To install the print wheel, push it firmly onto the end of the print wheel motor shaft. Be sure the alignment slot on the print wheel (Figure 1-5) fits into the tab protruding from the shaft hub (Figure 1-4).

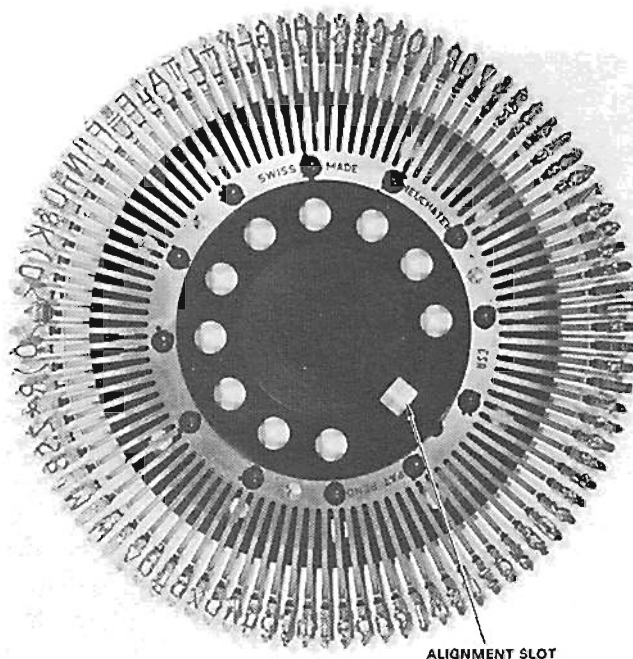

Figure 1-5. Print Wheel

6. Place the Release Lever back into position by moving it to the extreme right, back as far as it will go, and to the left until it locks in place.
7. Replace the ribbon cartridge as previously described.
8. Close the front cover.

1.7 FUSE REPLACEMENT

The mainline fuse is located in the rear of the printer. The fuse is changed by twisting the bad fuse out of the socket and replacing it with a new fuse. The printer should be turned OFF when changing a fuse.

1.8 CONTROLS AND INDICATORS

The control panel on the Model 2281W contains a number of switches and light indicators for manually controlling the operations of the printer (refer to Figure 1-6).

ON/OFF SWITCH

To turn the printer on, press the ON rocker switch at the rear of the printer. The POWER lamp at the control panel is illuminated. To turn off the printer, press the OFF switch; the POWER lamp is extinguished.

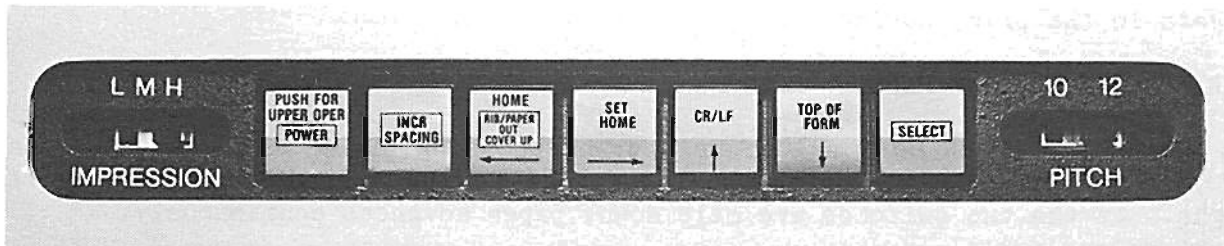

Figure 1-6. The Model 2281W Control Panel

The switches on the control panel are active only when the printer is deselected (SELECT lamp extinguished). Several switches possess more than one function. The control panel operates in the following manner.

LOWERCASE OPERATIONS

←, →, ↑, ↓ : If the INCREMENTAL SPACING switch has not been pressed (i.e., INCR SPACING lamp is out), these switches produce movement in increments of a character width (10- or 12-pitch) in the X-direction and a standard line feed (6 lines per inch) in the Y-direction. Pressing the switches briefly produces a single step motion. When the switches are held down, a more rapid, continuous motion is produced.

INCREMENTAL SPACING

When this switch is pressed, a lamp beneath it illuminates. The ← and → switches now produce incremental motion of 1/60 inch in the X-direction. The ↑ and ↓ switches produce incremental motion of 1/48 inch in the Y-direction. Pressing the switches briefly produces a single step motion. If the switches are held down, a more rapid continuous motion results. The INCREMENTAL SPACING switch remains active until disabled by again pressing INCR SPACING. This extinguishes the lamp beneath it and returns the Model 2281W to either 10- or 12-pitch standard character horizontal spacing and a 6 lines per inch vertical spacing.

UPPERCASE OPERATIONS

If this switch is held down while another function switch is pressed, the uppercase operations (HOME, SET HOME, CR/LF, TOP OF FORM) are active. For example, pressing the HOME switch will now move the platen and return the print wheel carriage to the current home position of the form instead of causing carriage motion.

SELECT

After turning on the printer, press the SELECT switch; the SELECT lamp is illuminated. When the SELECT lamp is illuminated the printer is ready to receive data from the CPU; however, it is not yet selected as the printing device. (Refer to the SELECT statement in Chapter 2.) When the SELECT switch is pressed again, the SELECT lamp is extinguished and the printer is temporarily deactivated (deselected). The SELECT switch can be used to halt printing temporarily (as when changing paper or ribbon) without causing loss of data in the print buffer.

CARRIAGE RETURN-LINE FEED

With the UPPER OPER switch held down, pressing CR/LF advances the paper one line and returns the print wheel carriage to the currently selected left margin. If the two switches are held down, paper advances continuously.

TOP OF FORM

With the UPPER OPER switch held down, pressing TOP-OF-FORM causes continuous form paper to be automatically advanced 11 inches or to the top of the next form. When inserting new paper, it should be manually adjusted to the paper's top-of-form position. Adjust the paper to the actual top of form by manually rolling the platen to the top of the form while pressing the right-hand platen knob, then hold in the right-hand platen knob (carriage clutch) while pressing the TOP-OF-FORM switch once. When the platen drive motor ceases to move, the top-of-form position has been set.

SET HOME

With the UPPER OPER switch held down, the SET HOME switch sets the home position $X=0$, $Y=0$ at the current print wheel position on the form. This is typically done when initially aligning a form or plot if the program controlling the output requires it.

HOME

With the UPPER OPER switch held down, the HOME switch is used to return the carriage and platen to the current home position.

RIB/PAPER OUT/COVER UP

When this lamp is illuminated, it indicates that one of the following printer conditions exists.

1. The ribbon cartridge should be changed.
2. The printer is out of paper.
3. The printer cover is not on securely.
4. A printer malfunction has occurred.

The printer should be deselected and the condition corrected. Printing is resumed by pressing the SELECT switch.

PITCH

The PITCH switch is located on the front of the chassis, to the right of the SELECT switch. The switch is used to select the appropriate format for 10-pitch (132 column line) or 12-pitch (157 column line) format. To select 10 characters per inch, set the switch to 10; to select 12 characters per inch, set the switch to 12.

NOTE:

For proper character spacing, 10-pitch must be set with a 10-pitch character wheel and 12-pitch must be set with a 12-pitch character wheel.

PLATEN RELEASE KNOB (PLATEN CLUTCH)

The right-hand platen knob disengages the platen mechanism to allow for setting the top-of-form and is used in conjunction with the TOP-OF-FORM function switch. Note that when the printer is on, all platen movements must be made with the platen knob held in.

PRINT INTENSITY ADJUSTMENT SWITCH

Three levels, or steps, of print intensity are provided on the Model 2281W to accommodate print wheel font variations as well as multiple copy printing. The print intensity switch is located inside the front cover on the right side. Print intensity levels shown on the switch are as follows.

- H -- High, used for printing multiple forms.
- M -- Medium, used for printing on single sheets.
- L -- Low, used for light printing to extend the life of the more delicate, light type fonts.

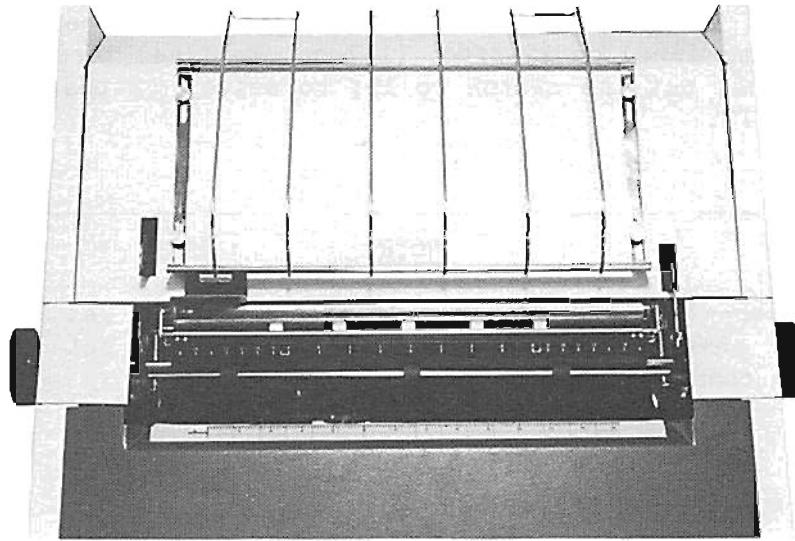

Figure 1-7. Platen Levers

PAPER RELEASE LEVER

The rightmost lever controls the position of the platen tray with respect to the paper (refer to Figure 1-7). When the lever is in the rear position, the tray presses against the paper and secures it in place. When the lever is moved forward, the platen tray is retracted from the platen and the paper can be moved and adjusted freely.

PAPER THICKNESS LEVER

The leftmost lever controls the position of the platen relative to the print wheel. Markings on the lever slot are A, B, C, D, E, and F. The lever is moved to the A position for single form operation. The lever should be moved towards the F position for multiple forms operation.

1.9 FORM ALIGNMENT

In addition to its printing and plotting capabilities, the Model 2281W has a set of built-in features specifically for aligning the print wheel to any position on a preprinted form. Form alignment can be performed manually (via the control panel) or by control codes in a program (refer to Chapter 5). For all printing, plotting, and form-filling applications, the Model 2281W can space, line-feed, and carriage return in non-standard typewriter increments and move the character entry position to any location on a form irrespective of the position and length of data in previously typed fields. The print wheel can move in standard character spacing of 10- or 12-pitch or in incremental spacing of 1/60 inch. Likewise, the platen can move in the standard line feed spacing of 6 lines per inch or in multiples of 1/48 inch spacing.

NOTE:

On a normal typewriter, horizontal carriage positioning is limited to single character widths (10-pitch or 12-pitch). Likewise, vertical positioning is limited to standard line feed increments, normally based on 6 lines per inch. This is often not sufficient to accurately align printed output on a form line feed especially if the form was not designed for use in a typewriter.

Manual Form Alignment

The print wheel/platen can be manually aligned on a preprinted form by any of the following control switches.

- SET HOME -- Aligns the print wheel and platen at the desired position on the form using the ↑, ←, →, and ↓ switches. Press the SET HOME switch to set Home at this position.

- TOP-OF-FORM -- Sets the Top-Of-Form to any line on a form. Using the ↑ and ↓ switches, move the platen to the Top-Of-Form. Hold in the right platen knob (carriage clutch) while pressing the TOP-OF-FORM switch. When the platen drive motor stops moving, the Top-Of-Form is set.

- Print Wheel Motion -- The print wheel can be moved left or right in either 10-pitch or 12-pitch increments. Likewise movements can be made in 1/60 inch increments.

- HOME -- Moves the print wheel and platen back to the last Home position.

- Platen Motion -- The paper in the platen can be moved up or down in standard 1/6 inch increments or in 1/48 inch increments.

Programmable Form Alignment

The Model 2281W provides a set of form filling commands (HEX codes) for positioning output on preprinted forms. These positioning commands are divided into two groups, and described in greater detail in Chapter 5.

1. Move to Fixed Position
2. Set Left Margin/Set Line Feed Spacing

The Move commands allow the print wheel/platen to be positioned anywhere on the form to an accuracy of 1/60 inch horizontally and 1/48 inch vertically when referenced to a preset Home position. The Home position identifies the absolute zero reference point on the form, generally the upper left-hand corner of the first page.

The Set Left Margin command sets the left margin at a position other than the default (power on) left margin. The Set Line Feed Spacing command sets the line feed increment to other than the standard 1/6 inch per line. These commands are useful for preprinted forms which do not have standard line feed and carriage return spacing.

Forms

Most forms can be divided into three general classes.

1. Those designed for typewriter output, with standard 10- or 12-pitch character spacing and line feed size (6 lines per inch).
2. Those conforming for the most part to typewriter spacing, but with some non-standard sections.
3. Those not designed for typewriter output, consisting mainly of non-standard character and line feed spacing.

The first classification requires none of the special form filling commands available with the Model 2281W. These can be handled using only the standard format features found in the BASIC language (PRINT, PRINT TAB, PRINT USING, etc.)

The non-standard portions of the second classification can be handled using the HEX commands for Set Line Feed size and Set Left Margin distance, followed by the normal BASIC printed output. For example, the non-standard portion of such a form might consist of a double column of figures starting 4 1/2 inches from the left margin, with the columns being 15 characters apart. The line feed spacing for each column might be 12 lines per inch. After filling out the first part of the form using standard BASIC print techniques, the left margin and line feed size could be set using the HEX form filling commands and the column data printed.

Forms in the third classification are best handled by the HEX form filling commands that generate non-standard movements and line feed spacings. For instance, the code HEX(E7) is used to move the print carriage and platen to a specified location on the form. When the HEX(E7) command is accompanied by a semicolon, the print argument which follows is printed starting at the specified location.

CHAPTER 2
SELECTING THE MODEL 2281W FOR OUTPUT

2.1 THE SELECT STATEMENT

The SELECT statement must be used by the operator to select the Model 2281W as the output device. A SELECT statement can either be used in the Immediate Mode or as a statement within a program. When used to select the Model 2281W, the syntax of the SELECT statement requires that it contain a BASIC verb (PLOT, PRINT, LIST, or CO), and a three-digit Device Address code (xyy) consisting of a Device Type (x) and a Unit Address code (yy). Line length can also be specified in printing operations.

Example 1:

```
:100 SELECT PRINT 2 15 (132)
Device Type  ————↑
Unit Address ————↑
Line Length  ————↑
```

If line length is not specified in a SELECT PRINT, SELECT LIST, or SELECT CO statement, the line length defaults to the standard default width of the CRT. In a system with an 80-column CRT, the standard line length is 80 characters and it is 64 columns with a 16 x 64 CRT.

Example 2:

```
:SELECT PRINT 215
:10 PRINT "THE MODEL 2281W PRINTER BIDIRECTIONALLY PRINTS
132 CHARACTERS ON A FULL LINE WHEN 10-PITCH IS SELECTED
AND 157 CHARACTERS ON A FULL LINE WHEN 12-PITCH IS
SELECTED."
:RUN (EXECUTE)
```

Output: (Line length default = 64 characters)

THE MODEL 2281W PRINTER BIDIRECTIONALLY PRINTS 132 CHARACTERS ON A FULL LINE WHEN 10-PITCH IS SELECTED AND 157 CHARACTERS ON A FULL LINE WHEN 12-PITCH IS SELECTED.

Device Type

The Device Type digit (x) in the Device Address code determines which of the system I/O routines are used to control the Printer. The Model 2281W automatically executes a line feed (i.e., advances the paper to a new line) following the execution of a carriage return; it is thus usually selected with a device type of 2 when printing (refer to Table 2-1). Generally, carriage return commands are initiated from the Wang System CPU. At the end of a full character line (132 or 157 characters), the printer automatically prints characters in its buffer and executes a carriage return/line feed.

Table 2-1 Device Types

Type	Operation
0	Device Type 0 usually addresses devices that do not automatically execute a line feed after a carriage return. With this device type, your Wang CPU executes a line feed after each carriage return; therefore when this device type is selected, the Model 2281W printed output is double-spaced, because the Model 2281W also executes a line feed after each carriage return.

Example:

```
:SELECT PRINT 015 (80)
:10 FOR I=1 TO 4
:20 PRINT "AABBCCDDEEFFGGHHIIJJKKLLMMNNOOPPQQRRSSTTUUVVWW"
:30 NEXT I
:RUN (EXECUTE)
```

Output:

```
AABBCCDDEEFFGGHHIIJJKKLLMMNNOOPPQQRRSSTTUUVVWW

AABBCCDDEEFFGGHHIIJJKKLLMMNNOOPPQQRRSSTTUUVVWW

AABBCCDDEEFFGGHHIIJJKKLLMMNNOOPPQQRRSSTTUUVVWW

AABBCCDDEEFFGGHHIIJJKKLLMMNNOOPPQQRRSSTTUUVVWW
```

- 2 This Device Type 2 addresses devices that automatically execute a line feed after a carriage return and is the device type normally used with the printer for PRINT, LIST, and CO operations. With this device type, output is single-spaced since no additional line feed is issued by the CPU.

Example:

```
:SELECT PRINT 215
:10 FOR I=1 TO 5
:20 PRINT "AABBCCDDEEFFGGHHIIJJKKLLMMNNOOPPQQRRSSTT"
:30 NEXT I
:RUN (EXECUTE)
```

Example 3:

```
:10 SELECT PLOT 415
:20 PLOT 10<5,, "***">
```

Output:

NOTE:

If the Model 2281W is connected to a 2200VP/MVP, a SELECT PLOT C15 should be used to decrease the plotting time.

Unit Address

The unit address of the Model 2281W controller is preset to 15 by Wang Laboratories before the unit is shipped, and must be the address used in SELECT statements dealing with the printer (e.g., SELECT PRINT 215). If a second Wang printer is used on the same CPU, it is assigned device address 16 by the Wang Service Representative who installs the system.

Line Length

Line length is an optional parameter in a SELECT PRINT, SELECT LIST, or SELECT CO statement which specifies the number of characters to be sent out to the printer before the system sends out a carriage return and resets the internal line count. Line length is normally varied to accommodate paper of different widths. The maximum number of characters per line that can be printed in the Model 2281W is either 132 or 157 characters depending on pitch selection (10- or 12-pitch). In the SELECT statement, line length is indicated in the parentheses following the Device Selection Code. Line length is not usually specified in the SELECT PLOT statement. For example:

SELECT PRINT 215 (80)	Selects the Model 2281W for printing and sets line length to 80.
SELECT CO 215 (64)	Selects the Model 2281W for console output and sets line length to 64.
SELECT LIST 215 (130)	Selects the Model 2281W for listing a program and sets line length to 130.

If a line length is not specified for PRINT, LIST, or CO, either the default or the last line lengths selected for these operations are used. Note that the default line length set during Master Initialization is 64 characters (80 characters with an 80-column CRT). The maximum line length which can be specified in a SELECT statement is 255. However, the use of a line length greater than 132 or 157 characters is not recommended. A longer line count typically produces two carriage returns; one done automatically by the printer when a full line of characters has been printed, another sent out by the system when the line count specified in the SELECT PRINT statement is exceeded. Specifying a shorter line length causes a carriage return to be sent out when the line count is exceeded.

Example 1:

```
:5 REM EXAMPLE OF USING A LINE LENGTH LESS THAN THE MAXIMUM NUMBER
    OF CHARACTERS IN THE PRINT LINE
:10 SELECT PRINT 215 (5)
:20 PRINT "THE MODEL 2281W PRINTS UP TO 157 CHARACTERS PER LINE"
:RUN (EXECUTE)
```

Output:

```
THE M
ODEL
2281W
PRINT
S UP
TO 15
7 CHA
RACTE
RS PE
R LIN
E
```

Note that embedded spaces in the line are included in the line count.

Example 2:

```
:10 REM EXAMPLE OF USING A LINE LENGTH GREATER THAN 157
:20 SELECT PRINT 215 (160)
:30 PRINT "THIS LINE INCLUDING SPACES HAS 175 CHARACTERS;
    THEREFORE SINCE IT IS LONGER THAN THE LINE LENGTH OF 160
    (GREATER THAN 157) SPECIFIED IN LINE 20 IT WILL PRINT
    OUT IN THREE LINES."
:RUN(EXECUTE)
```

Output: (Reduced)

```
THIS LINE INCLUDING SPACES HAS 175 CHARACTERS; THEREFORE SINCE IT IS LONGER THAN THE LINE LENGTH OF 160 (GREATER THAN 157) S
PECIFIED IN LINE 20 IT WILL PRINT OU
T IN THREE LINES.
```

The line length setting is used by the Wang system to generate an automatic carriage return when a line exceeds the specified line length and no carriage return is supplied by the program. As a line is output on the Model 2281W, the CPU keeps a count of the number of characters sent (line count). If this line count equals the current value of the line length before the output line is complete, a carriage return is transmitted to the printer, the line count is reset to zero, and the unfinished output is continued on the next line.

Example 3:

```
:SELECT PRINT 215(20)
:10 PRINT "ABCDEFGHIJKLMNOPQRSTUVWXYZ"
:RUN(EXECUTE)
```

Output:

```
ABCDEFGHIJKLMNQRST
UVWXYZ
```

If the output is complete and a carriage return is transmitted before the line count equals the line length, the system automatically resets the line count to zero for the start of a new line (a PRINT statement with no trailing comma or semicolon causes a carriage return to be executed at the end of the output).

Example 4:

```
:10 REM EXAMPLE OF PRINT STATEMENTS WITH NO TRAILING
    COMMA OR SEMICOLON
:20 SELECT PRINT 215(30)
:30 PRINT "KEEP"
:40 PRINT "OUT"
:RUN(EXECUTE)
```

Output:

```
KEEP
OUT
```

The line count is reset to zero under any one of the following conditions.

1. The line count equals the line length.
2. A carriage return is output when a PRINT, PRINTUSING, or HEXPRINT statement with no trailing punctuation (colon or semicolon) is executed.

3. The RESET switch on the system keyboard is pressed.
4. A CLEAR command is executed.
5. The system is Master Initialized.
6. A SELECT PRINT statement is executed.

2.2 SELECT PLOT

:SELECT PLOT 415 (or SELECT PLOT C15-2200VP/MVP only)

This statement selects the Model 2281W for plotting operations. Plot can be selected in Immediate Mode or as a statement within a program.

Example:

Program Mode	Immediate Mode
:10 SELECT PLOT 415	:SELECT PLOT 415
:20 PLOT 50 <5, "*" >	:10 PLOT 50 <5, "*" >

When either of these programs is executed, the plotter output is:

2.3 SELECT PRINT

:SELECT PRINT 215 (132)

This statement selects the printer with Device Address Code 215 for all program output resulting from the execution of PRINT, PRINTUSING, or HEXPRINT statements. Output resulting from PRINT and HEXPRINT statements entered in the Immediate Mode appear on the CRT unless the printer is also selected for CO (refer to Section 2.5).

Example 1:

Program Mode	Immediate Mode
:10 SELECT PRINT 215	:SELECT PRINT 215
:20 PRINT "N", "2 to the Nth"	:20 PRINT "N", "2 to the Nth"
:25 PRINT	:25 PRINT
:30 FOR X=0 TO 8	:30 FOR X=0 TO 8
:40 PRINT X, 2 ↑ X	:40 PRINT X, 2 ↑ X
:50 NEXT X	:50 NEXT X

When either of these programs is executed, the printer output is:

N	2 to the Nth
0	1
1	2
2	4
3	8
4	16
5	32
6	64
7	128
8	256

Example 2:

```
:10 SELECT PRINT 215
:20 X=7:Y=2.0:Z=5
:30 PRINT USING 40, X;Y;Z
:40 % ##.#
:RUN (EXECUTE)
```

Output:

7.0 2.0 5.0

Example 3:

```
:5 DIM A$25
:10 SELECT PRINT 215 (40)
:20 A$ = "THE 2281W PRINTER/PLOTTER"
:30 HEXPRINT A$
:RUN (EXECUTE)
```

Output:

544845203232383157205052494E5445522F504C4F54544552

2.4 SELECT LIST

:SELECT LIST 215

This statement selects the printer with Device Type Code 215 for all LIST operations. Output from the Disk Catalog Index can also be listed on the printer.

NOTE:

The default address for LIST operations is 005 (the CRT).

Example:

```
:SELECT LIST 215
:5 DIM A$25
:10 REM AN EXAMPLE USING THE PRINTER FOR LISTING
:100 A$ = "MODEL 2281W PRINTER/PLOTTER"
:999 PRINT A$
:8900 END
:LIST (EXEC)
```

Output:

```
5 DIM A$25
10 REM AN EXAMPLE USING THE PRINTER FOR LISTING
100 A$ = "MODEL 2281W PRINTER/PLOTTER"
999 PRINT A$
8900 END
```

2.5 SELECT CO (CONSOLE OUTPUT)

:SELECT CO 215 (40)

This statement selects the printer with Device Type Code 215 and a line length of 40 for all console output. This includes all system displays, such as the READY message, output from STOP and END statements, any data keyed in on the keyboard and entered into the CPU, and all output from Immediate Mode operations, TRACE statements, and error messages.

2.6 COMBINING SELECT PARAMETERS

It is possible to combine parameters in a SELECT statement.

Example:

```
SELECT PRINT 215 (100), LIST 215(80), CO 215 (112)
```

However, it is not possible to select two output devices with the same parameter. For example, the following statement produces a listing of programs on the CRT only.

```
SELECT LIST 215, LIST 005
```

2.7 DESELECTING THE MODEL 2281W

To deselect the printer, use one of the following methods.

1. Select another device for PRINT, LIST, or CO by using the SELECT statement.
2. Master Initialize (turn system power switch off, then on). Master Initialization selects the CRT for all LIST, PRINT, and CO operations.
3. Key in CLEAR and touch the RETURN/EXECUTE key. PRINT and LIST operations are returned to the device currently selected for Console Output (CO). If the printer is currently the CO device, either Step 1 or 2 must be used to deselect it.
4. Turn off the SELECT lamp. This is the only method of deselection which does not lose the data in the printer buffer. This method should be used when temporary deselection is required as when changing the paper or ribbon cartridge.

CHAPTER 3
GENERATING OUTPUT WITH THE PLOT STATEMENT

3.1 THE PLOT STATEMENT

The PLOT statement provides the ability to either move incrementally on a form or plot incrementally using BASIC program variables to specify increments. Other move commands specified by hex codes are described in Chapter 5. Move commands allow either absolute (relative to home) or incremental movement using binary values to specify the increments.

The PLOT statement applicable to the Model 2281W is of the following general form:

$$\text{PLOT } \left[\text{Expression 0} \right] < \left[\text{Expression 1} \right], \left[\text{Expression 2} \right], \left[\begin{array}{l} \text{null} \\ \text{literal string} \\ \text{alpha variable} \\ \text{hex control codes} \end{array} \right] >, \dots$$

Where: Expression 0: Represents the "replication factor" or the number of times the values inside the plot enclosures, , are plotted. If omitted, Expression 0 is assumed to be 1.

$(1 \leq \text{Expression 0} < 1000)$

Expression 1: Represents ΔX increments of 1/60 in. (0.0423 cm).

$(-1000 \leq \text{Expression 1} < 1000)$

When positive (+) move to the right, when negative (-) move to the left. If omitted, Expression 1 is assumed to be 0.

Expression 2: Represents ΔY increments of 1/48 in. (0.0529 cm).

$(-1000 < \text{Expression 2} < 1000)$

When positive (+) move up, when negative (-) move down. If omitted, Expression 2 is assumed to be 0.

NOTE:

Motion 'up' is up on the plot, i.e., paper in. Motion 'down' is down on the plot, i.e., paper out.

All three expressions are truncated to integers.

"Null" (a blank space) implies moving the typing element the ΔX and ΔY distance specified in Expressions 1 and 2, without plotting. Literal strings and alpha variables (e.g., A\$) can be any character or characters to be printed/plotted. Hex control codes are used to format output and are described in Chapter 5.

3.2 PLOT EXAMPLES

Example 1: NULL

```
:SELECT PLOT 415
:10 C=40 : D=50
:20 PLOT<C-10, D+20,>
:RUN(EXEC)
```

Result 1:

Advance X=30 increments and Y=70 increments without plotting.

Example 2: Literal String

```
:SELECT PLOT 415
:10 PLOT<20, , "ABC">
:RUN(EXEC)
```

Result 2:

Advances X=20 increments and Y=0 increments and prints 'ABC'.

Example 3: Alpha Variable

```
:SELECT PLOT 415
:20 A$="PRINT THIS"
:30 X = 10
:40 PLOT <X, 10, A$>
:RUN(EXEC)
```

Result 3:

Advances X=10 increments and Y=10 increments, then prints 'PRINT THIS'.

Example 4: Hex Control Codes

```
:10 SELECT PLOT 415
:20 PLOT < , , HEX(E5)>
:RUN(EXEC)
```

Result 4:

Causes a Power On Set Home to be executed.

CHAPTER 4 FORMATTING OUTPUT WITH THE PRINT STATEMENT

4.1 PRINT, PRINTUSING, AND HEXPRINT STATEMENTS

The PRINT, PRINTUSING, and HEXPRINT statements are used with the Model 2281W in the same manner as the CRT, although more 16-character print zones are available on the printer.

When 10-pitch is selected, the Model 2281W has a line length of 132 characters, divided into eight zones of 16 characters each and one zone of 4 characters. The zones constitute columns 0-15, 16-31, 32-47, 48-63, 64-79, 80-95, 96-111, 112-127, and 128-131, respectively.

When 12-pitch is selected, the Model 2281W has a line length of 157 characters, divided into nine zones of 16 characters each and one zone of 13 characters. The zones constitute columns 0-15, 16-31, 32-47, 48-63, 64-79, 80-95, 96-111, 112-127, 128-143, and 144-156, respectively.

Zone Format

If commas separate elements in a PRINT statement, then each element begins at the start of a new zone. When the system encounters a comma preceding a print element, it outputs spaces until it reaches the first character position of the next zone. It then outputs the value of the print element starting at that position.

Example 1: PRINTING IN ZONED FORMAT WITH COMMAS

```
:20 SELECT PRINT 215 (132)
:30 PRINT "COLUMNS 0-15", "COLUMNS 16-31", "COLUMNS 32-47"
:RUN (EXECUTE)
```

Output:

```
COLUMNS 0-15      COLUMNS 16-31      COLUMNS 32-47
```

Example 2: SKIPPING OVER ZONES WITH COMMAS

```
:20 SELECT PRINT 215 (157)
:30 PRINT "ACCOUNT NO.",,,"BALANCE DUE"
:40 PRINT "(COLUMNS 0-15)",,,"(COLUMNS 48-63)"
:50 PRINT 10082,,153.19
:RUN (EXECUTE)
```

Output:

ACCOUNT NO.
(COLUMNS 0-15)
10082

BALANCE DUE
(COLUMNS 48-63)
153.19

NOTE:

In zone printing on the Model 2281W, it is important to make sure that information supplied to the last zone does not exceed the legal length of the last zone (either 4 or 13 characters long depending on pitch selection). For instance, in a 10-pitch format, if the information for the last zone exceeds 4 columns, then the information is printed in the first zone of the next line.

Example:

```
:10 SELECT PRINT 215 (124)
:20 PRINT "NO.",1.2,3.4,5.6,7.8,9.0,8.4,10.2,"BALANCE
DUE NOW"
```

Output:(compressed)

```
NO.    1.2    3.4    5.6    7.8    9.0    8.4    10.2
BALANCE DUE NOW
```

In the previous example the ninth element in line 20 exceeded four characters in length and thus was printed in the next line.

Packed Format

If semicolons separate elements in a PRINT statement, the output appears in a packed format, with no spaces between items. In packed format, no additional blanks are added to the print line; blanks in the print line occur only when explicitly part of an alpha value or according to the rules for numeric values.

Example 1:

```
:SELECT PRINT 215
:10 A=1234 : B = -5678
:20 PRINT "ABC" ; "DEF"
:30 PRINT A;B
:RUN(EXECUTE)
```

Output:

```
ABCDEF
1234 -5678
```

Example 2:

```
:20 SELECT PRINT 215 (132): DIM A$18
:30 A$= "4-BEDROOM SALT BOX": P$= "$53,000"
:40 PRINT "STYLE:"; A$; " PRICE:"; P$
:RUN (EXECUTE)
```

Output:

```
STYLE:4-BEDROOM SALT BOX PRICE $53,000
```

NOTE:

A semicolon at the end of a PRINT statement supresses the normal line feed at execution.

Example:

```
:10 SELECT PRINT 215
:20 PRINT "FAR-";
:30 PRINT "OFF"
:RUN(EXECUTE)
```

Output:

```
FAR-OFF
```

Example 3: FORMATTING WITH PRINTUSING STATEMENT

```
:20 SELECT PRINT 215 (157): DIM A$ 18
:30 A$= "4-BEDROOM SALT BOX": P=53000
:40 PRINTUSING 50, A$,P
:50 % STYLE ##### PRICE-###,###
:RUN (EXECUTE)
```

Output:

```
STYLE 4-BEDROOM SALT BOX PRICE-$53,000
```

Example 4: PRINTING WITH HEXPRINT STATEMENT

```
:20 SELECT PRINT 215 (157)
:30 A$="ABC DEF GHI JKL"
:40 HEXPRINT A$
:RUN (EXECUTE)
```

Output:

4142432044454620474849204A4B4C20

PRINTUSING Statement

To print columns of information across a line, or print numeric and/or alphanumeric values according to an exact image, the PRINTUSING statement can be used to specify the print format. For a complete discussion of the PRINTUSING statement, refer to the BASIC Language Reference Manual applicable to the system's CPU.

Example 1:

```
:10 X=1: Y=2: Z=3
:20 PRINTUSING 30, X; Y; Z
:30 % #.#
:RUN(EXEC)
```

Output:

1.0 2.0 3.0

Example 2:

```
:100 PRINTUSING 200
:200 % PROFIT AND LOSS STATEMENT
:RUN(EXEC)
```

Output:

PROFIT AND LOSS STATEMENT

Example 3:

```
:50 A$="J. SMITH": T=923751
:100 PRINTUSING 200, A$, T
:200 % SALESMAN ##### TOTAL SALES $$$,###.##
:RUN(EXEC)
```

Output:

SALESMAN J. SMITH TOTAL SALES \$9,237.51

Example 4:

```
:10 X=2.3: Y=27.123
:20 PRINT USING 30, X, Y
:30 % ANGLE -#####.##### LENGTH=+##.#
:RUN(EXEC)
```

Output:

```
ANGLE          2.300000 LENGTH=+27.1
```

4.2 The PRINT TAB(); Function

The PRINT TAB(); function can be used to position the print location prior to typing a character. When a PRINT statement containing a TAB(); function is executed, the Model 2281W skips to the column specified by the integer portion (in parentheses) of the TAB(); expression, and then prints the indicated argument.

Example 1:

```
:SELECT PRINT 215(157)
:10 PRINT TAB(75);"MASTER SEWERAGE PLAN"
:20 PRINT: PRINT
:30 PRINT TAB(40);"STREET";TAB(70);"LINE FEET";
    TAB(110);"PIPE DIA.";TAB(130);"CONNECTIONS"
:RUN (EXECUTE)
```

Output:

```
MASTER SEWERAGE PLAN

STREET          LINE FEET          PIPE DIA.          CONNECTIONS
```

In the above example "MASTER SEWERAGE PLAN" is printed starting at column 75; likewise, the headings in line 30 are printed at the specified tab settings.

If the value of the TAB(); expression is greater than the selected line length, the printer moves to the next line and completes the PRINT statement starting at Column 0.

Example 2:

```
:10 SELECT PRINT 215
:20 A=25
:30 PRINT TAB(A);"TANK MODEL";TAB(3*A);"CREW SIZE"
RUN (EXECUTE)
```

Output:

```
TANK MODEL

CREW SIZE
```

NOTE:

If the carriage position in the line being printed is greater than the TAB(); argument, the tab is ignored. For example, in the following statement the TAB(5); is ignored.

```
10 PRINT "123456789"; TAB(5); "No."
```

When using the TAB(); function to print numeric values in columnar format, an additional column (to the left of the value) is allocated for the sign (+ or -). If it is not used (for positive numbers), actual printing begins at the column specified, plus one.

Example 3:

```
:10 SELECT PRINT 215 (80)
:20 PRINT TAB(10);"POWER";TAB(20);"VALUE"
:30 FOR N=-1 TO 10
:40 PRINT TAB(10);N;TAB(20);(-2)↑N
:50 NEXT N
:RUN (EXECUTE)
```

Output:

POWER	VALUE
-1	-.5
0	1
1	-2
2	4
3	-8
4	16
5	-32
6	64
7	-128
8	256
9	-512
10	1024

CHAPTER 5 FORMATTING OUTPUT WITH HEX CODES

5.1 THE HEX FUNCTION

The HEX function is used in a BASIC program to output characters on the printer (both those that do and do not appear on the standard keyboards) or to execute special Printer Control Codes. The HEX function has the following form.

HEX(hh [hh] [..] .)

Each h equals a hex digit, 0 to 9, or a letter, A to F. An even number of characters must always appear in a HEX function; spaces are not allowed. (Refer to Appendix A for a complete listing of hexadecimal character codes and control codes.)

Hex codes for characters and/or printer control can be combined. For example, the following program in memory:

```
:10 SELECT PRINT 215
:20 PRINT HEX (410D0A42)
:RUN (EXECUTE)
```

produces: A

B

when run, since the code for 'A' is HEX(41), 'carriage return' is HEX(0D), 'line feed' is HEX(0A), and 'B' is HEX(42).

5.2 MODEL 2281W CONTROL CODES

When the Model 2281W receives a hex code for a printable character, it simply places the code into its print buffer. Unless the buffer is full, no immediate action is taken. However, certain special hex codes do not enter the buffer and instead cause immediate action by the printer. These special codes are the printer control codes.

Set Left Margin HEX(E8XXXX)

The Set Left Margin control code allows the operator to select a left margin location which is an integer multiple of 1/60 inch. The left margin distance is specified from the current home position. Following the definition of a new left margin, all BASIC output will be justified relative to the new margin specified. XXXX equals the margin specification (2's complement hexadecimal format) representing the number of 1/60 inch increments from the current home position. (Refer to Appendix C for converting distance to 2's complement hexadecimal format.)

The left margin is reset to its default value (the extreme left margin) under the following conditions.

1. The printer is powered on.
2. A HEX(E5) command is executed.

Example 1:

```
:10 SELECT PRINT 215  
:20 PRINT HEX(E80078);  
:30 PRINT " LEFT MARGIN"
```

Result 1:

This program sets the left margin at a point 2 inches to the right of the current home position and prints LEFT MARGIN starting at that point.

Example 2:

```
:10 SELECT PRINT 215  
:20 PRINT HEX(E8FFC4);
```

Result 2:

This program sets the left margin at a point 1 inch to the left of the current home position.

Note in these examples the use of the semicolon at the end of the PRINT statement to suppress line feed.

Table 5-1 provides a convenient conversion of physical distance to hexadecimal values for use with the Set Left Margin control code.

Table 5-1. Conversion of Physical Distance to Hexadecimal Values Based on 1/60 Inch Increments

Left Margin Distance From Current Home (inches)	XXXX Value In HEX(E8XXXX)	Left Margin Distance From Current Home (inches)	XXXX Value In HEX(E8XXXX)
0	0000		
1	003C	-1	FFC4
2	0078	-2	FF88
3	00B4	-3	FF4C
4	00F0	-4	FF10
5	012C	-5	FED4
6	0168	-6	FE98
7	01A4	-7	FE5C
8	01E0	-8	FE20*
9	021C	-9	FDE4
10	0258	-10	FDA8
11	0294	-11	FD6C
12	02D0	-12	FD30

The XXXX values shown in Table 5-1 are derived using the procedures discussed in Appendix C and illustrated in the following example.

Determine the hexadecimal value (in 2's complement format) for a left margin of -6 inches.

Step 1: Find the number of 1/60 increments in 6 inches.

$$6 \text{ } 1/60 = 360$$

Step 2: Convert 360 into a hexadecimal number

$$360 = \text{HEX}(0168)$$

Step 3: Find the 2's complement of HEX(0168)

$$\begin{aligned} &\text{complement HEX}(0168)+1 \\ &= \text{complement } (0000 \ 0001 \ 0110 \ 1000)+1 \\ &= 1111 \ 1110 \ 1001 \ 0111+1 \\ &= 1111 \ 1110 \ 1001 \ 1000 \\ &= \text{HEX}(FE98) \end{aligned}$$

* Refer to Appendix D.

Example 3:

```
:400 REM SET LEFT MARGIN TO 4
      INCHES AND LINE FEED
      SIZE TO 3.5 LINES/IN.
:410 PRINT HEX (E800FOE90DBF);
:420 REM OUTPUT COLUMN DATA
:430 FOR I = 1 TO 15
:440 PRINTUSING 460, A(I), B(I)
:450 NEXT I
:460 %$#,###.## $##.##
:470 REM RESET LEFT MARGIN TO
      ZERO AND LINE FEED
      SIZE TO 6 LINES/IN.
:480 PRINT HEX (E80000E90800);
```

Result 3:

A set of 15 items are printed (in the PRINTUSING format of line 460) in two columns spaced 15 character spaces apart (zone format). The first column is set 4 inches to the right of the home position. The items are printed at 3.5 lines per inch.

Move (Absolute) HEX(E7XXXXYYYY)

The Move (Absolute) command moves the carriage to the desired absolute X and Y position on a form (relative to home) without regard to the current location. This command allows the carriage to be repositioned to a specified location from the home reference position with an accuracy of 1/60 inch X and 1/48 inch Y. XXXX and YYYY (2's complement hexadecimal format) are the number of horizontal (1/60 inch) and vertical (1/48 inch) increments from home. (Refer to Appendix C for converting distance to 2's complement hexadecimal format.)

NOTE:

The YYYY values for vertical movements in the HEX(E7) command cause the platen to move as follows.

A positive YYYY moves down on the form (paper out).

A negative YYYY moves up on the form (paper in).

Example 1:

```
:SELECT PRINT 215
:10 PRINT HEX(E7003C0060);
```

Result 1:

Moves 1 inch to the right and 2 inches down from the current home position.

Example 2:

```
:10 SELECT PRINT 215
:20 PRINT HEX(E70000FDC0);
```

Result 2:

Moves 12 inches up from the current home position.

The following table provides a convenient conversion of physical distance to hexadecimal values for vertical movement (YYYY). Table 5-1 can be used for the XXXX values in the HEX(E7XXXXYYYY) code.

Table 5-2. Conversion of Physical Distance to Hexadecimal Values Based on 1/48 Inch Increments

Vertical Distance Down From Home Position (inches)	YYYY Value In HEX(E7XXXXYYYY)	Vertical Distance Up From Home Position (inches)	YYYY Value In HEX(E7XXXXYYYY)
1	0030	-1	FFD0
2	0060	-2	FFA0
3	0090	-3	FF70
4	00C0	-4	FF40
5	00F0	-5	FF10
6	0120	-6	FEE0
7	0150	-7	FEBO
8	0180	-8	FE80
9	01B0	-9	FE50
10	01E0	-10	FE20*
11	0210	-11	FDF0
12	0240	-12	FDC0

The YYY values shown in Table 5-2 are derived using the procedures discussed in Appendix C and illustrated in the following example.

Determine the hexadecimal value (in 2's complement format) for a vertical movement of -6 inches:

Step 1: Find the number of 1/48 inch increments in 6 inches.

$$6 \div 1/48 = 288$$

Step 2: Convert 288 into a hexadecimal number.

$$288 = \text{HEX}(0120)$$

Step 3: Find the 2's complement of HEX(0120)

$$\begin{aligned} \text{complement } \text{HEX}(0120) + 1 &= \text{complement}(0000\ 0001\ 0010\ 0000) + 1 \\ &= 1111\ 1110\ 1101\ 1111 + 1 \\ &= 1111\ 1110\ 1110\ 0000 \\ &= \text{HEX}(FEE0) \end{aligned}$$

* Refer to Appendix D.

Example 3:

```
:10 SELECT PRINT 215
:20 A$="NAME" :B$="ADDRESS" :C$="TELEPHONE NO."
:30 PRINT HEX(E7003C0000); A$
:40 PRINT HEX(E700B40000); B$
:50 PRINT HEX(E7012C0000); C$
:60 PRINT HEX(E700B4FFD0); "CLASS LISTING"
:RUN (EXECUTE)
```

Output:

CLASS LISTING

NAME	ADDRESS	TELEPHONE NO.
------	---------	---------------

Set Line Feed Spacing HEX(E9YYFF)

The Set Line Feed Spacing code allows program selection of any line feed spacing which is a multiple of 1/48 inch. This allows the user to specify nonstandard line spacings. YYFF defines the line feed spacing. The first byte (YY) equals an integer multiple of 1/48 inch, and the second byte (FF) equals a fractional part of the 1/48 inch step increment (1/256 increment). If a fractional part (FF) of an increment is specified, the printer always rounds off each line feed to the nearest whole increment (1/48). It also maintains an error correction factor which minimizes the positional offset at the end of long forms. Note that line feed spacing is always positive.

The line feed spacing is reset to the default value of 6 lines per inch under any one of the following conditions.

1. The printer is powered on.
2. The current line feed spacing command is cleared from memory.
3. A HEX(E5) command is executed.

Table 5-3. Conversion of Physical Lines Per Inch Values to Hexadecimal Form

Line Feed Spacing in Lines/in.	Increments between lines		YYFF in HEX(E9YYFF)
	1/48 in. Increments	1/256 in. Increments	
1	48	0	3000
1.5	32	0	2000
2	24	0	1800
2.5	19.2	51	1333
3	16	0	1000
3.5	13.714	183	0DB7
4	12	0	0C00
4.5	10.606	170	0AAA
5	9.6	154	099A
5.5	8.727	186	08BA
6 (default value)	8	0	0800
6.5	7.38	98	0762
7	6.857	219	06DA
7.5	6.4	102	0666
8	6	0	0600
8.5	5.647	166	05A6
9	5.33	85	0555
9.5	5.05	13	050D*
10	4.8	205	04CD
11	4.364	94	045E
12	4	0	0400
13	3.692	177	03B1
14	3.429	110	036E
15	3.2	51	0333
16	3	0	0300
17	2.824	211	02DE
18	2.667	171	02AB
19	2.526	135	0287
20	2.4	102	0266
21	2.286	73	0249
22	2.182	47	022F
23	2.087	22	0216
24 (quarter line)	2	0	0200

* Refer to Appendix D.

The YYFF values shown in Table 5-3 are derived using the procedures discussed in Appendix C and illustrated in the following example.

Example: Determine the hexadecimal value for a line spacing of 0.4 inches or 2.5 lines/in.

Step 1: Find the number of 1/48 inch increments in 0.4 inches.

$$(0.4) \div (1/48) = 19.2$$

Step 2: Convert 19 into its hexadecimal value.

$$19 = \text{HEX}(13)$$

Step 3: Find the number of 1/256 inch increments in 0.2.

$$(0.2) \div (1/256) = 51.2 = 51 \text{ (rounded off)}$$

Step 4: Convert 51 into its hexadecimal value.

$$51 = \text{HEX}(33)$$

Step 5: Combine the hexadecimal values obtained in Steps 2 and 4.

$$\text{HEX}(13) \text{ and } \text{HEX}(33) = \text{HEX}(1333)$$

Example 1:

```
:100 PRINT HEX(E91000);
```

Result 1:

This statement sets the line feed size at an even 16 increments/line, or 3 lines/inch.

Example 2:

```
:100 PRINT HEX(E9099A);
```

Result 2:

This statement sets the line feed size at 9.6 increments, or 5 lines/inch.

Example 3:

```
: 90 REM QUARTER LINE FEED
:100 PRINT HEX(E90200); " 2    2    2"
:110 PRINT HEX(E90200); "a  + b  = r"
```

Result 3:

$$a^2 + b^2 = r^2$$

Example 4:

```
: 5 REM QUARTER LINE FEED
:10 PRINT HEX(E90200); "a  + b  = r"
:20 PRINT HEX(E90200); " x    y"
```

Result 4:

$$a_x + b_y = r$$

Example 5:

```
:10 SELECT PRINT 215
:15 REM 1 LINE PER IN.
:20 PRINT HEX(E93000);
:30 FOR A = 1 TO 2
:40 PRINT "AAAAAAA"
:50 NEXT A

:55 REM 2 LINES PER IN.
:60 PRINT HEX(E91800);
:70 FOR B = 1 TO 3
:80 PRINT "BBBBBBB"
:90 NEXT B

:95 REM 3 LINES PER IN.
:100 PRINT HEX(E91000);
:110 FOR C = 1 TO 4
:120 PRINT "CCCCCCC"
:130 NEXT C

:135 REM 4 LINES PER IN.
:140 PRINT HEX(E90C00);
:150 FOR D = 1 TO 5
:160 PRINT "DDDDDDD"
:170 NEXT D

:175 REM 5 LINES PER IN.
:180 PRINT HEX(E9099A);
:190 FOR E = 1 TO 6
:200 PRINT "EEEEEEE"
:210 NEXT E

:215 REM 6 LINES PER IN.
:220 PRINT HEX(E90800);
:230 FOR F = 1 TO 6
:240 PRINT "FFFFFFF"
:250 NEXT F
```

Result 5:

```
AAAAAAA

AAAAAAA

BBBBBBB

BBBBBBB

BBBBBBB

BBBBBBB

CCCCCCC

CCCCCCC

CCCCCCC

CCCCCCC

DDDDDDD

DDDDDDD

DDDDDDD

DDDDDDD

DDDDDDD

EEEEEEE

EEEEEEE

EEEEEEE

EEEEEEE

EEEEEEE

FFFFFFF

FFFFFFF

FFFFFFF

FFFFFFF

FFFFFFF
```

Example 5: (continued)

Result 5 (continued)

```

:255 REM 7 LINES PER IN.
:260 PRINT HEX(E906DA);
:270 FOR G = 1 TO 7
:280 PRINT "GGGGGGG"
:290 NEXT G

```

```

GGGGGGG
GGGGGGG
GGGGGGG
GGGGGGG
GGGGGGG
GGGGGGG
GGGGGGG

```

```

:295 REM 8 LINES PER IN.
:300 PRINT HEX(E90600);
:310 FOR H = 1 TO 8
:320 PRINT "HHHHHHH"
:330 NEXT H

```

```

HHHHHHH
HHHHHHH
HHHHHHH
HHHHHHH
HHHHHHH
HHHHHHH
HHHHHHH
HHHHHHH

```

```

:335 REM 9 LINES PER IN.
:340 PRINT HEX(E90555);
:350 FOR I = 1 TO 9
:360 PRINT "IIIIIII"
:370 NEXT I

```

```

IIIIIII
IIIIIII
IIIIIII
IIIIIII
IIIIIII
IIIIIII
IIIIIII
IIIIIII
IIIIIII

```

```

:375 REM 10 LINES PER IN.
:380 PRINT HEX(E904CD);
:390 FOR J = 1 TO 10
:400 PRINT "JJJJJJJ"
:410 NEXT J

```

```

JJJJJJJ
JJJJJJJ
JJJJJJJ
JJJJJJJ
JJJJJJJ
JJJJJJJ
JJJJJJJ
JJJJJJJ
JJJJJJJ
JJJJJJJ

```

Move Incremental Long HEX(E0XXXYYYY)

The Move Incremental Long command moves the number of X and Y increments (1/60 inch for X and 1/48 inch for Y) specified, from the current carriage position. A two-byte 2's complement hexadecimal representation for each X and Y specifying up to + 32,766 increments. Actual X increments are limited by the width of the platen. (Refer to Appendix C for converting distance to 2's complement hexadecimal format).

NOTE:

The YYYY values for vertical movements in the HEX(E0) command cause the platen to move as follows.

A negative YYYY moves the platen forward (normal paper advancement).

A positive YYYY moves the platen backwards (paper retraction).

Example 1:

```
:100 SELECT PRINT 215
:200 PRINT HEX(E0007F0040)
```

Result 1:

Causes the print carriage to move X = +127 increments, and Y = +64 increments from the current character entry position.

Example 2:

```
:5 SELECT PLOT 415
:10 PLOT < , , HEX(E0FF060190)>
```

Result 2:

Causes the print carriage to move X = -250 increments (to the left) and the platen Y = 400 increments from the current position.

Move Incremental Short HEX (E6XXYY)

The Move Incremental Short command moves the number of X (1/60 inch) and Y (1/48 inch) increments specified from the current carriage position. A one byte 2's complement hexadecimal representation for each X and Y specifying up to +127 increments. (Refer to Appendix C for converting distance to 2's complement hexadecimal format).

NOTE:

The YY values for the vertical movements in the HEX(E6) command cause the platen to move as follows.

A negative YY moves the platen forward (normal page advancement).

A positive YY moves the platen backwards (paper retraction).

The following table provides a convenient conversion of physical distance to hexadecimal values for use in HEX(E6XXYY).

Table 5-4. Conversion of Physical Distance to Hexadecimal Values

Increments between lines		
Horizontal Distance (inch)	1/60 in. Increments	XX value in HEX(E6XXYY)
.5	30	1E
1.0	60	3C
1.5	90	5A
2.0	120	78
2.1167	127	7F
-.5	-30	E2
-1	-60	C4
-1.5	-90	A6
-2	-120	88
-2.1167	-127	81
Vertical Distance (inch)	1/48 in. Increments	YY value in HEX(E6XXYY)
.5	24	1B
1	48	30
1.5	72	48
2.0	96	60
2.5	120	78
2.64	127	7F
-.5	-24	E6
-1	-48	D0
-1.5	-72	B8
-2	-96	A0
-2.5	-120	88
-2.64	-127	81

Example:

```
:SELECT PRINT 215
:10 PRINT HEX(E678D0);
```

Result:

Causes the carriage to move 2 inches to the right and 1 inch down from the current character entry position.

Set Home HEX(E4)

Under program control, this code duplicates the function of setting the home position (X=0, Y=0) which is done manually via the Set Home switch on the control panel. The Set Home command defines the current carriage position as the home position.

Examples:

```
:100 PRINT HEX(E4);  
:100 PLOT < , , HEX(E4)>
```

Processing Continuous Forms

When using the Model 2281W to process continuous forms, there are two ways of moving to the start of the next form. If the form is a standard length (i.e., 11 inches), the 'Top-Of-Form' Hex Code (HEX(OC)) may be used when the current form is complete. For example:

```
:900 PRINT HEX(OC);
```

If the form length is other than 11 inches, the following procedure involving the Incremental Move command (HEX(E7XXXXYYYY)) and the Set Home command (HEX(E4)) can be used.

1. Convert the form length from inches to vertical increments of 1/48 inch (Table 5-2). This constant value (VVVV) will be used in Step 3.
2. Manually set a home position on the first form (refer to Section 1.9).
3. When the first form has been completed, the carriage and the platen may be moved to the identical position on the next form by using a combination of the Incremental Move command and the Set Home command as follows.

```
:900 PRINT HEX(E70000VVVVE4);
```

Power On Home HEX(E5)

This control code moves the print wheel to the Power On position at the left end of the carriage. The form does not move in the vertical direction. The home position and left margin position are automatically redefined at the absolute left margin position and the line feed size defaults to 6 lines/inch; all preset tabs are also cleared. This command may be used to reinitialize the programmable formatting features of the Model 2281W without powering down the printer. It is useful when changing from one form to another. In this case it should be one of the last commands issued by the program controlling the first form.

Backspace HEX(08)

The Backspace code causes the internal line buffer pointer to be decremented by one character. Characters entered prior to the Backspace code(s) may be underscored (using HEX(5F)). Non-space characters will not be overwritten, but previous spaces can be filled in with new characters.

Example 1:

```
:100 PRINT "REPORT #113 - CHEMICAL  
ANALYSIS";  
:110 HEX(080808080808080808080808080808080808);  
:120 HEX(5F5F5F5F5F5F5F5F5F5F5F5F5F5F5F5F5F5F)
```

Output:

```
REPORT #113 - CHEMICAL ANALYSIS
```

Example 2:

```
:100 PRINT "NAME ="; HEX(080808080808); "XXX"
```

Output:

```
NAME =
```

Example 3:

```
:100 PRINT "TABLE#          IS FULL";  
:110 PRINT HEX(080808080808080808080808080808080808);"N13046-52"
```

Output:

```
TABLE# N13046-52 IS FULL
```

TAB HEX(09)

The TAB command causes the internal line buffer pointer to be incremented to the next preset TAB location.

Example:

```
:10 REM TAB IS PRESET AT COLUMN 30  
:15 PRINT TAB(30); HEX(1A)  
:20 PRINT HEX(09);"REPORT TITLE"
```

Execution of this program causes 'REPORT TITLE' to be printed starting at column 30.

Line Feed HEX(OA)

The Line Feed command causes the current contents of the line buffer to be printed and advances the paper one line.

Example:

```
:10 PRINT "WATCH";  
:20 PRINT HEX(OA);"YOUR";  
:30 PRINT HEX(OA);"STEP"
```

Output:

```
WATCH  
      YOUR  
          STEP
```

Vertical TAB HEX(OB)

The paper in the printer is divided into 11 zones of six lines each starting with the Top-of-Form. A HEX(OB) code advances the paper to the start of the next six-line zone.

Example:

```
:10 PRINT "LIST OF DONORS"  
:20 PRINT HEX(OB);"NAME";  
      TAB(25);"BLOOD TYPE"
```

Output:

```
LIST OF DONORS  
  
NAME          BLOOD TYPE
```

Reverse Index HEX(FA)

The Reverse Index command moves the platen backwards, one line at a time, with line spacing interval specified by the Set Line Feed Spacing command HEX(E9).

Example:

```
:10 SELECT PRINT 215
:20 PRINT HEX(E93000);
:30 PRINT HEX (FA)
```

Output:

Moves the platen backwards one line. The line spacing interval is one line per inch.

Top-Of-Form HEX(OC)

This command advances the paper to the top of the next form (11-inch form assumed).

Example:

```
:10 PRINT "LIST OF DONORS"
.
.
.
:250 PRINT "THIS CONCLUDES THE
LIST OF DONORS"
:260 REM START NEW LISTING
:270 PRINT HEX(OC);
```

Carriage Return HEX(OD)

The Carriage Return code prints the current contents of the line buffer and advances the paper one line.

Example:

```
:10 PRINT "SPARE PARTS LIST"
:20 PRINT HEX(ODODOD)
:30 PRINT "ITEM", "QUANTITY"
```

Output:

```
SPARE PARTS LIST
ITEM          QUANTITY
```

Clear TAB HEX(19)

The CLEAR TAB command (HEX(19)) is used to remove a tab from the printer's internal tab buffer. To remove a preset tab, the printer must be positioned internally at the tab location. This may be done by using the TAB function.

Example 1:

```
:10 SELECT PRINT 215(132)
:15 PRINT TAB(10); HEX(1A); TAB(25); HEX(1A);
    TAB(40); HEX(1A); TAB(55); HEX(1A);
    TAB(100); HEX(1A)
:20 PRINT HEX(0919)
:RUN(EXEC)
```

In this program, line 15 sets tabs in columns 10, 24, 38, 52, and 96. Line 20 then uses the TAB code (09) to position the buffer pointer at the first tab location (column 10) and the CLEAR TAB code (19) to remove the tab.

```
:20 PRINT HEX(09090919090919)
```

This statement clears the third and the fifth preset tabs.

All preset tabs are automatically cleared when the printer power is turned on, or when a HEX(E5) command is executed. A simple BASIC routine, such as the following one, may be used to clear all tabs under program control.

Example 2:

Clear all possible preset tabs from all print positions (I) in the printer's tab buffer.

```
:10 SELECT PRINT 215(255)
:20 FOR I = 1 TO 131
:30 PRINT HEX(0919);
:40 NEXT I : PRINT
:RUN(EXEC)
```

The semicolon is placed at the end of statement 30 to suppress the normal carriage return (0D); otherwise a line would advance each time statement 30 was executed. A similar example for 12-pitch is as follows.

```
:10 SELECT PRINT 215(255)
:20 FOR I = 1 TO 156
:30 PRINT HEX(0919);
:40 NEXT I : PRINT
:RUN(EXEC)
```

Set TAB HEX(1A)

The set TAB code (HEX(1A)) is used to set a tab in the printer's internal tab buffer. Before setting a tab, the printer's internal line buffer pointer must be set to the correct location in the line. The TAB() function may be used to accomplish this.

Example 1:

```
:10 SELECT PRINT 215(132)
:20 PRINT TAB(10); HEX(1A)
:RUN(EXEC)
```

Statement 20 sets a tab at column 10 of the print line.

Care must be taken when using the TAB() function to set multiple tabs on the printer. Since the SET TAB code HEX(1A) does not begin with a zero hex digit, it causes the 2200 CPU's internal line count to be incremented by one each time it is executed. To compensate for this, the succeeding TAB() function arguments must all be incremented as well.

Example 2:

```
:10 SELECT PRINT 215(132)
:20 PRINT TAB(10); HEX(1A); TAB(21); HEX(1A); TAB(102); HEX(1A)
:RUN(EXEC)
```

Statement 20 sets tabs at columns 10, 20, and 100.

If tabs are to be set near the end of the print line, it is generally advisable to select a line length greater than 132 (10-pitch) or 157 (12-pitch). Otherwise, the TAB() argument may become greater than the actual length and cause an unwanted carriage return code HEX(0D) to be executed by the 2200 CPU.

Example 3:

```
:10 SELECT PRINT 215(255)
:20 FOR I = 10 TO 130 STEP 10
:30 PRINT TAB(I + K); HEX(1A);
:40 K = K + 1
:50 NEXT I :PRINT
:RUN(EXEC)
```

This routine sets tabs at columns 10, 20, 30, 40, 50, ..., 120, 130 of the print line, although the TAB() function arguments are 10, 21, 32, 43, 54, ..., 131, 142.

Underscore HEX(5F)

The HEX(5F) code places an underscore in the line buffer at the current location of the internal line buffer pointer.

Example 1:

```
:10 PRINT "NO SMOKING PLEASE";  
:20 PRINT HEX(080808080808);  
:30 PRINT HEX (5F5F5F5F5F5F)
```

Output:

NO SMOKING PLEASE

Note that since the Underscore code does not begin with a zero hex digit the 2200's internal line count is incremented as each underscore is executed. If underscoring is to be done near the end of the print line, it is advisable to select a line length greater than 132 (10-pitch) or 157 (12-pitch) to prevent an unwanted carriage return from being executed by the 2200 CPU.

Example 2:

```
:10 SELECT PRINT 215(255)  
:20 PRINT TAB (120); "AB";  
:30 PRINT HEX(08085F5F)
```

Delete HEX(7F)

The Delete code clears the buffer of characters sent before the '7F'.

Example:

```
:100 PRINT "TITLE=";  
:110 PRINT HEX(7F);  
:120 PRINT "VALUE="
```

Output:

VALUE =

NOTE:

When control codes HEX(0B), HEX(0C), or HEX(7F) are combined with print characters in a single PRINT line, the control code is executed first.

APPENDIX A
HEXADECIMAL CODES

<u>Hex Code</u>	<u>Printer Character</u>	<u>Hex Code</u>	<u>Printer Character</u>	<u>Hex Code</u>	<u>Printer Character</u>
HEX(08)	Backspace	HEX(3B)	;	HEX(60)*	Space
HEX(09)*	Tab	HEX(3C)*	<	HEX(61)	a
HEX(0A)	Line Feed	HEX(3D)	=	HEX(62)	b
HEX(0B)*	Vertical Tab	HEX(3E)*	>	HEX(63)	c
HEX(0C)*	Top-of-Form	HEX(3F)	?	HEX(64)	d
HEX(0D)	Carriage Return	HEX(40)	@	HEX(65)	e
HEX(19)*	Clear Tab	HEX(41)	A	HEX(66)	f
HEX(1A)*	Set Tab	HEX(42)	B	HEX(67)	g
HEX(1E)	¢	HEX(43)	C	HEX(68)	h
HEX(1F)*	Space	HEX(44)	D	HEX(69)	i
HEX(20)	Space	HEX(45)	E	HEX(6A)	j
HEX(21)	!	HEX(46)	F	HEX(6B)	k
HEX(22)	"	HEX(47)	G	HEX(6C)	l
HEX(23)	#	HEX(48)	H	HEX(6D)	m
HEX(24)	\$	HEX(49)	I	HEX(6E)	n
HEX(25)	%	HEX(4A)	J	HEX(6F)	o
HEX(26)	&	HEX(4B)	K	HEX(70)	p
HEX(27)	'	HEX(4C)	L	HEX(71)	q
HEX(28)	(HEX(4D)	M	HEX(72)	r
HEX(29))	HEX(4E)	N	HEX(73)	s
HEX(2A)	*	HEX(4F)	O	HEX(74)	t
HEX(2B)	+	HEX(50)	P	HEX(75)	u
HEX(2C)	,	HEX(51)	Q	HEX(76)	v
HEX(2D)	-	HEX(52)	R	HEX(77)	w
HEX(2E)	.	HEX(53)	S	HEX(78)	x
HEX(2F)	/	HEX(54)	T	HEX(79)	y
HEX(30)	0	HEX(55)	U	HEX(7A)	z
HEX(31)	1	HEX(56)	V	HEX(7B)*	. (centered dot)
HEX(32)	2	HEX(57)	W	HEX(7F)*	Clear Buffer
HEX(33)	3	HEX(58)	X	HEX(E0)*	Move (Long)
HEX(34)	4	HEX(59)	Y	HEX(E4)*	Set Home
HEX(35)	5	HEX(5A)	Z	HEX(E5)*	Power On Home
HEX(36)	6	HEX(5B)	[HEX(E6)*	Move (Short)
HEX(37)	7	HEX(5C)*	Space	HEX(E7)*	Move (Absolute)
HEX(38)	8	HEX(5D)*]	HEX(E8)*	Set Left Margin
HEX(39)	9	HEX(5E)*	!	HEX(E9)*	Set Line Feed
HEX(3A)	:	HEX(5F)*	Underscore	HEX(FA)*	Reverse Index

*Indicates a character that differs from the CRT Character Set.

APPENDIX B
SPECIFICATIONS

Printer Dimensions:

Height 9 in. (22.9 cm)
Depth. 25 in. (63.5 cm)
Width. 19.5 in. (49.5 cm)

Approximate Net Weight:

70 lb (31.5 kg)

Accuracy:

X - Direction: $\pm 1/60$ in. plus 0.003 in./in (± 0.0423 cm
plus 0.003 cm/cm)

Y - Direction: $\pm 1/48$ in. plus 0.003 in./in (± 0.0529 cm plus
0.003 cm/cm)

Character Element:

10-pitch or 12-pitch

Paper Specifications:

Material: margin perforated continuous fan-fold or discrete paper stock
Maximum form length: 11 in. (27.9 cm)
3.5 to 15 in. (8.9 to 38 cm) wide
Maximum number: four copies plus original.

For single part forms:

15 to 20 lb bond (20 lb recommended)

For multipart forms:

2 ply: 131/131 bond, 8 lb carbon
3 ply: 131/131/131 lb bond, 8 lb carbon
4 ply: 12/12/12/12 lb bond, 61 lb carbon
5 ply: 12/12/12/12/12/ lb bond, 61 lb carbon

Carbon:

8 lb (med. hard) for 1 and 2 ply; 61 lb for 3, 4, and 5 ply.

Character Set:

Alphanumeric (86 characters ASCII)

Buffer Size:

132 characters (10-pitch)
157 characters (12-pitch)

Cable:

12 ft (3.7 m) to controller board
8 ft (2.4 m) to power source

Controller:

Standard line printer/CPU interface

Power Requirements:

115 or 230 VAC \pm 10%
50 or 60 Hz \pm 1 Hz
250 watts

Fuses:

3.0 A (SB) for 115 VAC
1.5 A (SB) for 230 VAC

Operating Environment:

45°F to 95°F (7°C to 35°C)
-20° to 135°F (-29°C to 57°C), storage
10% to 80% relative humidity,
non-condensing allowable
35% to 65% relative humidity, recommended
0% to 90% relative humidity, storage

APPENDIX C
DECIMAL/BINARY 2'S COMPLEMENT CONVERSION

C.1 INTRODUCTION

Binary numbers consist of digits whose values can only be 0 or 1. These binary digits are called bits. Each higher order bit (digit) in a binary number represents a power of 2 greater than the bit to the right of it. For example:

The binary number represented by the bits $X_7X_6X_5X_4X_3X_2X_1X_0$ has a value of

$$X_7(2^7) + X_6(2^6) + X_5(2^5) + X_4(2^4) + X_3(2^3) + X_2(2^2) + X_1(2^1) + X_0(2^0)$$

Thus, if $X_7X_6X_5X_4X_3X_2X_1X_0 = 0000\ 1011$

Its value in the decimal system equals

$$\begin{aligned} &0(2^7) + 0(2^6) + 0(2^5) + 0(2^4) + 1(2^3) + 0(2^2) + 1(2^1) + 1(2^0) \\ &= 0 \quad + 0 \quad + 0 \quad + 0 \quad + 1(8) + 0 \quad + 1(2) + 1(1) \\ &= 11 \end{aligned}$$

Hexadecimal Notation

When used in a HEX command, a binary number must be represented in hexadecimal notation. In this representation, a binary number is divided into four-bit groups (from the right) and each group of four bits is expressed by a single hexadecimal character (refer to Table C-1).

Table C-1. Decimal/Binary/Hexadecimal Conversion

Decimal	Binary	HEX	Decimal	Binary	HEX	Decimal	Binary	HEX	Decimal	Binary	HEX
0	0000	0	8	1000	8	-1	1111	F	-8	1000	8
1	0001	1	9	1001	9	-2	1110	E	-9	0111	7
2	0010	2	10	1010	A	-3	1101	D	-10	0110	6
3	0011	3	11	1011	B	-4	1100	C	-11	0101	5
4	0100	4	12	1100	C	-5	1011	B	-12	0100	4
5	0101	5	13	1101	D	-6	1010	A	-13	0011	3
6	0110	6	14	1110	E	-7	1001	9	-14	0010	2
7	0111	7	15	1111	F				-15	0001	1

For example, $\text{HEX}(0B) = \underline{0000} \underline{1011} = 11$

↑ ↑
0 B

$\text{HEX}(2710) = \underline{0010} \underline{0111} \underline{0001} \underline{0000} = 10,000$

↑ ↑ ↑ ↑
2 7 1 0

In each pairing of hexadecimal characters, the first four digits are called "high-order" bits, and the four bits on the right are called "low-order" bits.

Representation of Positive Numbers in 2's Complement

The representation of positive decimal numbers in 2's complement format follows the usual procedure of converting a decimal number to its binary and/or hexadecimal value. For example:

4 = 0000 0100 = HEX(04)
11 = 0000 1011 = HEX(0B)
10,000 = 0010 0111 0001 0000 = HEX(2710)

Conversion of Negative Numbers to 2's Complement

A negative value in binary 2's complement format is formed in two operations. First, express the absolute value of the decimal number in binary or hexadecimal format as shown in the preceding section. Then complement the binary value (i.e., change all 1's to 0's and 0's to 1's) and add 1. Table C-1 can be used to facilitate the conversion of negative values to 2's complement format.

For example:

$-11 = \text{complement}(+11) + 1 = \text{complement of } 0000 \ 1011 + 1 =$
 $1111 \ 0100 + 1 = 1111 \ 0101 = \text{HEX}(F5)$

$-4 = \text{complement}(+4) + 1 = \text{complement of } 0000 \ 0100 + 1 =$
 $1111 \ 1011 + 1 = 1111 \ 1100 = \text{HEX}(FC)$

$-10,000 = \text{complement}(+10,000) + 1 = \text{complement of } 0010 \ 0111 \ 0001 \ 0000 + 1$
 $= 1101 \ 1000 \ 1110 \ 1111 + 1$
 $= 1101 \ 1000 \ 1111 \ 0000$
 $= \text{HEX}(D8F0)$

NOTE:

The high-order bit (left-most position) indicates the sign associated with the number.

0 = positive (+)

1 = negative (-)

Thus HEX(00) through HEX(7F) are positive and HEX(80) through HEX(FF) are negative.

Converting a hexadecimal number to its decimal equivalent follows the same procedure as in the previous examples. For example:

$$\text{HEX}(74) = \text{positive number} = (0111\ 0100) = 64+32+16+4 = 116$$

$$\begin{aligned}\text{HEX}(80) &= \text{negative number} = -(\text{complement}(\text{HEX}(80))+1) \\ &= -(\text{HEX}(7F)+1) \\ &= -(0111\ 1111 +1) \\ &= -(1000\ 0000) = -128\end{aligned}$$

NOTE:

Positive hexadecimal numbers can be translated directly to decimal values by using powers of 16. The HEX number represented by

$X_3X_2X_1X_0$ has a value of

$X_3(16^3)+X_2(16^2)+X_1(16^1)+X_0(16^0)$. Thus if

$X_3X_2X_1X_0 = 02CF$, its decimal equivalent is

$$0(4096)+2(256)+12(16)+15(1)=719.$$

C.2 CONVERSION OF BASIC NUMERIC VALUES TO 2'S COMPLEMENT

2200T Users

Numeric values can be converted into 2's complement binary numbers with the Wang BASIC BIN statement. The BIN statement converts a BASIC numeric value to binary. Since, however, the BIN statement produces only a binary value consisting of a single byte (8 bits), the number must be factored by 256 (the minimum value + 1 of the byte) to produce a two-byte number. The following BASIC subroutine receives a numeric value, (presumably an integer value less than 32,766) converts it to 2's complement binary notation and stores it in the first two bytes of the variable A\$.

```
:10 REM SUBROUTINE TO GENERATE TWO BYTE 2'S COMPLEMENT BINARY NUMBERS

:100 GOSUB' 50 (X1)                X1 = numeric integer value to be converted
                                   to 2's complement which will be
                                   stored in A$.

:400 DEFFN' 50 (X)
:404 DIM A$2
:405 IF ABS(X) <= 32766 THEN 410
:408 STOP: PRINT "ABS(X) TOO LARGE"
:410 T = INT (ABS(X)/256)          (Factor 256)
:420 BIN(A$) = T                  (Convert to form high-order byte)
:430 BIN(STR(A$,2)) = ABS(X)-T*256 (Convert to form low-order byte)
:440 IF SGN(X) < 0 THEN 450:RETURN (Check if negative, return if positive)
:450 XOR(STR(A$, 1, 2),FF)        (Complement binary value)
:460 ADDC(STR(A$, 1, 2),01)       (Add 1)
:470 RETURN
```

The following routine receives an integer value less than 128, converts it to 2's complement binary notation and stores it in the one byte variable A\$.

```
:10 REM SUBROUTINE TO GENERATE ONE BYTE 2'S COMPLEMENT NUMBER

:100 GOSUB' 60 (X1)                X1 = Numeric integer value between -128
                                   and +127 which will be converted to
                                   2's complement and stored in A$.

:500 DEFFN' 60 (X)
:505 DIM A$1
:510 BIN(A$) = ABS(X)              (Convert to binary)
:520 IF SGN(X) < 0 THEN 530: RETURN (Test if negative; return if positive)
:530 XOR(STR(A$,1,1),EF)          (If negative, complement)
:540 ADDC(STR(A$,1,1),01)         (Add 1)
:550 RETURN
```

2200VP Users

Numeric values can be converted directly into a two-byte, binary number by using the BASIC 2 BIN statement. The following routines can be used on the 2200VP system.

```
:10 REM SUBROUTINE TO GENERATE TWO BYTE 2'S COMPLEMENT BINARY NUMBERS
```

```
:100 GOSUB' 50 (X1)
```

```
  .  
  .  
  .  
:400 DEFFN' 50 (X)  
:410 DIM A$2  
:420 IF ABS(X) <= 32766 THEN 440  
:430 STOP: PRINT "ABS(X) TOO LARGE"  
:440 Y=ABS(X)  
:450 A$=BIN(Y,2)  
:460 IF SGN (X) < 0 THEN 470: RETURN  
:470 XOR(STR(A$,1,2),FF)  
:480 ADDC(STR(A$1,2),01)  
:490 RETURN
```

The following routine is used to convert a number less than 128 to a one-byte, 2's complement value.

```
:10 REM SUBROUTINE TO GENERATE ONE BYTE 2'S COMPLEMENT NUMBER
```

```
:100 GOSUB' 60 (X1)
```

```
  .  
  .  
  .  
  .  
:500 DEFFN' 60(X)  
:505 DIM A$1  
:510 Y = ABS(X)  
:520 A$ = BIN(Y)  
:530 IF SGN(X) < 0 THEN 540: RETURN  
:540 XOR(STR(A$,1,1),FF)  
:550 ADDC(STR(A$,1,1),01)  
:560 RETURN
```

APPENDIX D
 TRAILING SPACES HEX(20)
 OR THE HEX(0D) CODE IN AN ALPHA VARIABLE

D.1 TRAILING SPACES (HEX(20)) IN AN ALPHA VARIABLE

When an alpha variable is printed to a peripheral, the 2200 BASIC truncates all trailing spaces. This can present problems when the alpha variable is used to send plotting or forms positioning vectors to the Model 2281W.

For example:

```
: 10 DIM A$32
: 20 A$ = HEX(E701A90120)
: 30 PRINT A$; "SUB-TOTAL"
```

The variable A\$ is dimensioned large enough to hold a number of vector commands. In line 20, A\$ is set equal to a relative move command which should cause the form to be repositioned 425 increments to the right and 288 increments down from the form's home position (HEX (01A9) = decimal 425, HEX (0120) = decimal 288). Normally, the entire vector would be sent to the printer, followed by the ASCII codes for SUB-TOTAL.

i.e., HEX E7 01A9 0120 5355422D544F54414C 0D00
 ↑ ↑ ↑ ↑
 X Y SUB-TOTAL CR

The 2200 BASIC language, however, truncates all trailing spaces (HEX 20) including the last byte of the Y-vector (HEX 0120). What is sent to the Model 2281W is an incorrect code sequence.

i.e., HEX E7 01A9 0153 55422D544F54414C 0D00
 ↑ ↑ ↑ ↑
 X Y UB-TOTAL CR

The printer's internal microcode interprets the first code of the ASCII message (HEX 53) as the final byte of the Y-vector component. The printed output will therefore appear in the wrong position on the form, and the first character will be missing.

D.2 HEX (OD) IN AN ALPHA VARIABLE

Depending on the device type selected in the SELECT PRINT statement, the 2200 BASIC always inserts one or two control codes following the occurrence of a HEX (OD) code in an alpha variable. If the device type is 2 (SELECT PRINT 215), the HEX (OD) is followed by a HEX (00); if the device type is 4 (SELECT PRINT 415), the HEX (OD) is followed by a HEX (0A00). Needless to say, these codes are treated as part of the vector in the printers internal microcode.

Example 1: (Device Type 2)

```
:10 SELECT PRINT 215
:20 DIM A$32
:30 A$ = HEX(E7040D0135)
:40 PRINT A$; "SUB-TOTAL"
```

The desired output to the printer is the code sequence:

```
HEX E7 040D 0135 5355422D544F54414C 0D00
      ↑   ↑           ↑           ↑
      X   Y           SUB-TOTAL   CR
```

The actual code sequence is:

```
HEX E7 040D 0001 355355422D544F54414C 0D00
      ↑   ↑           ↑           ↑
      X   Y           5SUB-TOTAL   CR
```

Example 2: (Device Type 4)

```
:10 SELECT PRINT 415
:20 DIM A$32
:30 A$ = HEX(E7040D0135)
:40 PRINT A$; "SUB-TOTAL"
```

The desired output is the code sequence:

```
HEX E7 040D 0135 5355422D544F54414C 0D0A00
      ↑   ↑           ↑           ↑
      X   Y           SUB-TOTAL   CR/LF
```

The actual code sequence is:

```
HEX E7 040D 0A00 01355355422D544F54414C 0D0A00
      ↑   ↑           ↑           ↑
      X   Y (string not printed) CR/LF
```

D.3 PLOTTING WITH \$GIO

A common solution to the problems in D.1 and D.2 is to use \$GIO for outputting all plot or forms positioning vectors.* In the following examples the \$GIO statement sends only the specified portion of the alpha variable to the printer, with no additional control characters.

Example 3:

```
:10 SELECT PRINT 215
:20 DIM A$32, B$10
:30 A$ = HEX(E7010D0120)
:40 $GIO/015, (A000, B$) STR(A$,1,5)
:50 PRINT "SUB-TOTAL"
```

In the previous example, the \$GIO statement prevents additional control characters from being sent out following the OD code in A\$. Using the STR(function forces BASIC not to omit trailing spaces, so the HEX 20 is sent to the printer.

Example 4:

```
:10 SELECT PRINT 215
:20 DIM A$32, B$10
:30 INIT (00) A$
:40 STR (A$,1,5) = HEX(E7010D0120)
:50 STR (A$,6,9) = "SUB-TOTAL"
:60 STR (A$,15,2) = HEX(OD00)
:70 $GIO/015, (A000, B$) A$
```

In the previous example, all 32 bytes of A\$ are sent to the device. The printer's internal microcode correctly interprets all vector and print data, and ignores the trailing HEX 00 code.

* 2200T users -- Refer to General I/O Instruction Set Reference Manual (700-3514).
2200 VP/MVP users -- Refer to BASIC-2 Language Reference Manual (700-4080).

PREVENTIVE MAINTENANCE

It is recommended that your equipment be serviced quarterly. A Maintenance Agreement is available to assure this servicing automatically. If no Maintenance Agreement is acquired, any servicing must be arranged by the customer. A Maintenance Agreement protects your investment and offers the following benefits:

Preventive Maintenance: Your equipment is inspected quarterly for worn parts, lubricated, cleaned, and updated with engineering changes, if any. Preventive maintenance minimizes "downtime" by anticipating repairs before they are necessary.

Fixed Annual Cost: When you buy a maintenance agreement, you issue only one purchase order for service for an entire year and receive one annual billing; more frequent billing can be obtained, if desired.

Further information regarding Maintenance Agreements can be acquired from your local Sales Service Office.

NOTE:

Wang Laboratories, Inc. does not guarantee or honor maintenance agreements for any equipment modified by the user. Damage to equipment incurred as a result of such modification becomes the financial responsibility of the user.

WANG

LABORATORIES, INC.

TO: MODEL 2281W DAISY PRINTER USERS
FROM: CORPORATE PUBLICATIONS DEPARTMENT
SUBJECT: ADDENDUM TO MODEL 2281W PRINTER/PLOTTER USER MANUAL (700-5744)
DATE: MAY 9, 1980

Please insert the attached addendum, Appendix E: Bidirectional Forms Tractor Option, in the Model 2281W Printer/Plotter User Manual. This appendix describes the functions of the optional Bidirectional Forms Tractor accessory designed for operation on the Model 2281W daisy printer, and includes sections outlining installation procedure, paper insertion, print registration, and specifications.

Thank you

Corporate Publications Department

WANG

LABORATORIES, INC.

ONE INDUSTRIAL AVENUE, LOWELL, MASSACHUSETTS 01851, TEL. (617) 459-5000, TWX 710 343-6769, TELEX 94-7421

Printed in U.S.A.
700-5744.01
5-80-2.5M
Price: see current list

SECRET

CONFIDENTIAL

CONFIDENTIAL

SECRET

CONFIDENTIAL

CONFIDENTIAL

SECRET

APPENDIX E
BIDIRECTIONAL FORMS TRACTOR OPTION

E.1 INTRODUCTION

The Bidirectional Forms Tractor is an accessory designed for use with the Model 2281W and Model 2281WC daisy printers. When mounted on a printer, the Bidirectional Forms Tractor allows the continuous forward or reverse feeding of form paper.

This easy-to-use accessory offers many new applications for the Model 2281W and Model 2281WC printers, including forms filling, plotting, and superscript/subscript printing. The Bidirectional Forms Tractor accommodates various paper widths and multiform combinations of up to six parts (original plus five copies).

Two models exist: Model BFT-1 installs on the Model 2281W daisy printer, and Model BFT-2 installs on the Model 2281WC daisy printer. Each of the two tractor models includes racks to support ingoing and outgoing paper flow.

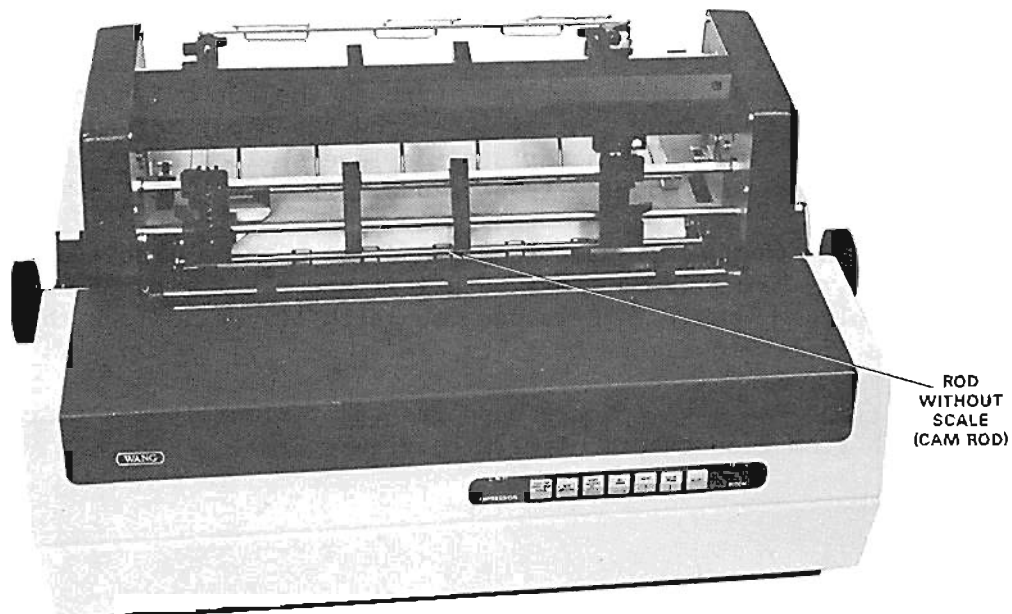

Figure E-1. BFT-1: Bidirectional Forms Tractor (using 2281W)

E.2 INSTALLATION PROCEDURES

Perform the following steps to install the Bidirectional Forms Tractor.

NOTE

Before the tractor is mounted on the printer, the paper scale and rod assembly over the platen must be removed and replaced with a rod without a scale (refer to Figure E-1). The rods are easily attached to the printer by a spring-loaded mount.

1. Pull the printer paper bail forward (away from the platen), and then pull the Paper Release Lever to its most forward position.
2. Remove the end covers of the printer, replacing them with the new end covers supplied with the Bidirectional Forms Tractor.
3. Install the paper rack, supplied with the tractor, on the rear cover of the daisy printer. Position left and right brackets over the four tapped holes on the rear of the printer. Insert the four thumb screws supplied, and tighten. The rack may then be easily placed into the slots on the brackets.
4. Center the Bidirectional Forms Tractor over the printer. Grip and pull upward the spring-loaded Latch Release Levers (refer to Figure E-2) beneath both left and right end covers of the tractor.
5. Determine that the printer's Copy Control Lever extends through the cut-out on the assembly's left slide bracket, and that the printer's Paper Release Lever extends through the cut-out on the right slide bracket. The Copy Control Lever and the Paper Release Lever will be controlled by the tractor's slide levers (located at the rear of the tractor assembly) during tractor use.
6. Position the left side frame into the bushing groove on left end of platen, making sure that both left and right tractor latches engage the platen shaft. Release the latch levers to lock the tractor in place (refer to Figure E-2).
7. Position the two paper supports approximately one-third the paper width from each tractor (refer to Figure E-2).

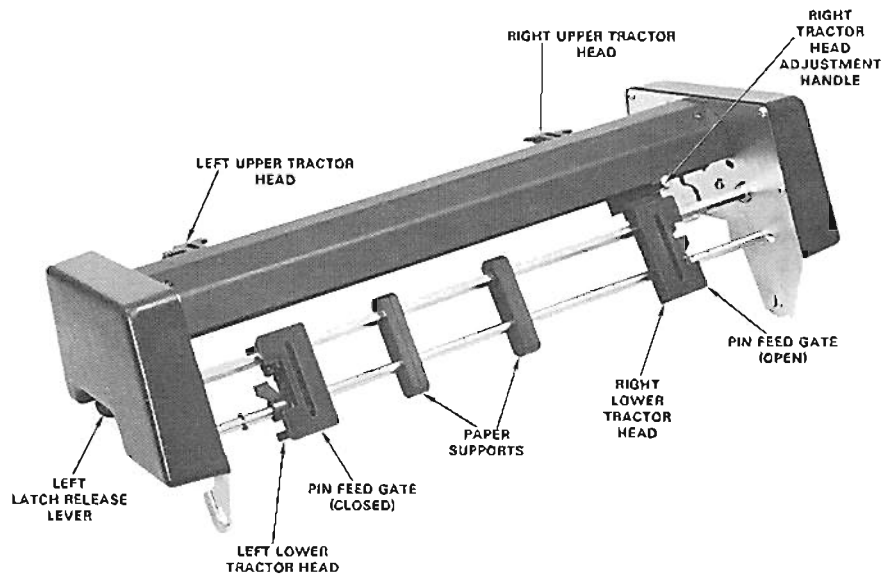

Figure E-2. Bidirectional Forms Tractor

E.3 PAPER INSERTION

To insert paper, perform the following steps.

1. Begin insertion of continuous form paper by guiding paper beneath the tilting rack mounted on the rear printer cover. Gently pull the paper and engage the first four holes of the left margin on the four pins of the upper left tractor head (refer to Figures E-2 and E-3).
2. Adjust the right-hand upper and lower tractor heads for the desired paper width. Note that both right-hand tractors are adjusted with a single handle. Open the pin feed gates on the forms tractor by gently pulling forward on the front of the gates. Engage the first four holes of the right margin on the pins of the upper right tractor head (refer to Figure E-2).
3. Rotate the platen to advance the paper over the tension rod and under the paper guide until the leading edge of the paper reaches the platen. Pull the Right Slide Lever back (away from the platen) to engage the feed rollers of the printer (refer to Figure E-3).
4. Determine that the paper is positioned in back of the cam rod (refer to Figure E-1).
5. Continue the rotation of the platen until 5.0 inches (12.7 cm) of paper extend in front of the platen. Move the Right Slide Lever forward (towards the platen) to release the feed rollers (refer to Figure E-3).
6. Load the paper into the left and right lower tractors. Close the pin feed gates by gently pushing them back (refer to Figure E-2).

7. Turn the platen knob to position the paper at the top of a page where the first line is to be printed. When printing, the paper should exit over the top of the upper rack towards the back of the printer.
8. Move the Left Slide Lever manipulating the printer's Copy Control Lever back as required for multi-part paper (refer to Figure E-3). For single sheet paper, the Left Slide Lever must be in the forward position.

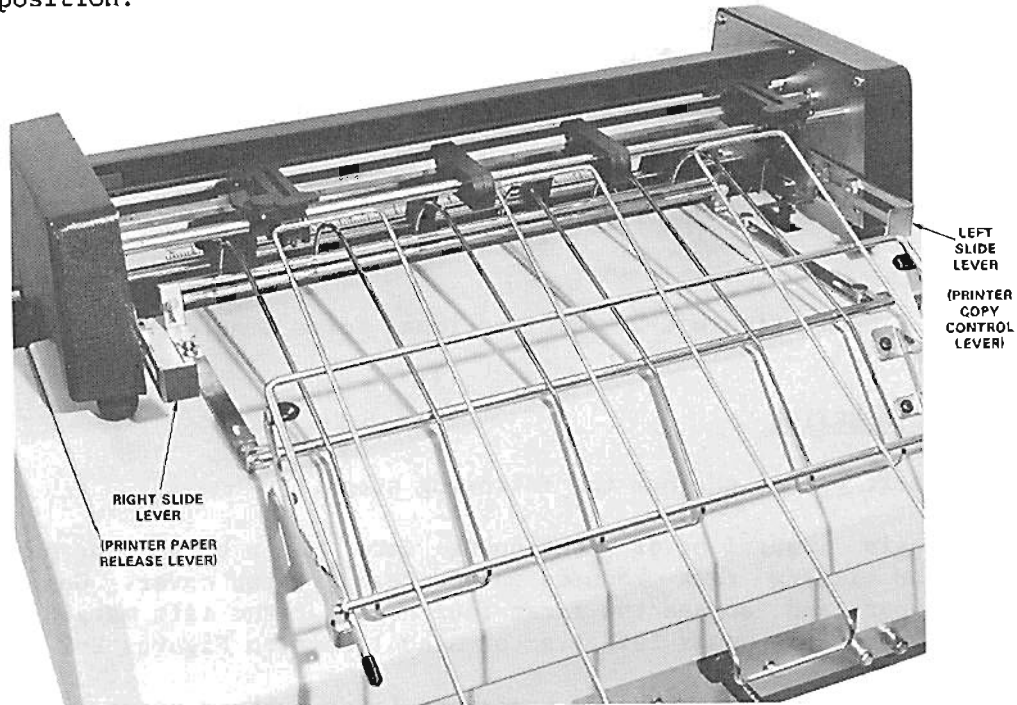

Figure E-3. Tractor Rack and Rod Assemblies

E.4 PRINT REGISTRATION

NOTE

All error limits mentioned in this section are based on a printing rate of six lines per inch.

The Home (power on) position of the left margin is established at the factory. For both BFT models, the center line of the first character is approximately 0.45 inch (1.143 cm) from the center line of the tractor head pin hole.

Line spacing, from the top of one line to the top of the following line, is 0.167 ± 0.015 inch (0.424 ± 0.038 cm) when paper is advanced in either the forward or reverse direction. The actual dimension between any two printed lines on an 11-inch (27.94 cm) page is within 0.023 inch (0.058 cm) of the nominal position. The nominal position should be calculated using the line feed rate of one inch (2.54 cm) per six printed lines.

Based on 13.50-inch (34.29 cm) paper, printed lines are parallel to perforations in continuous feed paper within 0.040 inch (0.102 cm) in reverse drive and 0.035 inch (0.089 cm) in forward drive.

When overstriking in the forward direction, printing and plotting registration is accurate within 0.010 inch (0.025 cm). When overstriking in reverse, registration is accurate within 0.030 inch (0.076 cm). Plotting accuracy is suitable for highlighting and visual aids. Do not use multi-part paper for plotting operations.

E.5 PAPER SPECIFICATIONS

The Bidirectional Forms Tractor can accommodate various widths of paper. The paper width restrictions for each printer are listed below. The Forms Tractor option is adjustable for multi-copy combinations of up to 6 copies.

<u>Model Number</u>	<u>Paper Width</u> <u>(center-hole to center-hole)</u>
BFT-1	2.0 to 13.50 inch (5.08 to 34.29 cm)
BFT-2	2.0 to 18.90 inch (5.08 to 48.00 cm)

Continuous form paper thickness may range from 0.003 inch (0.008 cm) (14 lb. substance, single copy) to 0.027 inch (0.069 cm) thick (various multi-copy combinations up to six parts). The cover sheet of multi-copy forms must be of at least 12 lb. substance.

Multi-part forms must be securely fastened at all four corners, but not glued, stapled, or taped. Forms perforations must be of sufficient strength to withstand normal paper handling force of the printer of approximately one inch per pound. Paper substance exceeding 24 pounds (90g/sq m) bond or excessive bulging of forms, particularly at perforations, may reduce the specified performance.

Holes in continuous form paper must be 0.156 ± 0.005 inch (0.396 ± 0.013 cm) in diameter, and on a $0.500 \pm .005$ inch (1.27 ± 0.013 cm) pitch.

Reverse feeding is not recommended across perforations.

E.6 BIDIRECTIONAL FORMS TRACTOR SPECIFICATIONS

Physical Characteristics

	<u>BFT-1</u>	<u>BFT-2</u>
Height	6.75 in. (17.15 cm)	6.75 in. (17.15 cm)
Width	21.50 in. (54.61 cm)	26.40 in. (67.06 cm)
Depth	8.40 in. (21.34 cm)	8.40 in. (21.34 cm)
Weight	6.00 lbs. (2.70 kg)	6.50 lbs. (2.93 kg)

Recommended Operating Environment

50 to 100 F (10 to 38 C)
40 to 65% relative humidity, noncondensing (recommended)
20 to 80% relative humidity, noncondensing (allowable)

NOTE

Operation should meet specifications only if paper is not adversely affected by these conditions.

INDEX

	Page
Absolute Move	35
Backspace	51
Backspace Code	45
Backwards Linefeed	47
Binary Notation	54
BIN Statement (2200T)	57
BIN Statement (2200VP)	57
Buffer Size	52
Carriage Return Code	47
Carriage Return Switch	8
Carriage Width	1, 52
Character Set	51
Clear Buffer	50
Clear TAB	48
Combined Parameters	22
Comma with PRINT Statement	26
Control Codes	24, 32
Control Panel	6
Cover Open	8
CPU	2
Decimal/Binary Conversion	55, 57
Delete Buffer	50
Deselecting the Printer	22
Device Address	13, 16
Device Selection	13
Device Type	13, 14
Element Separators in PRINT Statement	26, 27
Formatting Output (HEX Codes)	32-50
Form Alignment	10
Form Filling	10, 32, 44
Fuse Replacement	6
Hexadecimal Notations	32, 54
HEX Characters	32, 54
HEX Codes	32
HEX(OD) in Alpha Variable	60
HEXPRINT	26, 29
Home Position	8, 10, 44
Home Switch	8

Incremental Spacing	1, 7, 33
Initializing a Form	44
Introduction	1
Inspection	2
Installation	2
Left Margin	33
Left Movement Switch	7
Line Feed (Backwards)	47
Line Feed Code	46
Line Feed (Forwards)	46
Line Feed Spacing	37
Line Length	16
Lowercase Operations.	7
Lowercase Switches	7
Manual Form Alignment	10
Margins	33
Move	51
Absolute	35
Incremental Long	41
Incremental Short	42
Negative Numbers	55
Non-Standard Size Forms	10, 44
Null Command	24
Numeric Values	54
ON/OFF Switch	7
Out of Paper	8
Out of Ribbon	8
Output (Double-spaced).	14
Output (Single-spaced).	14-15
Packed Format	27
Paper Insertion	2
Paper Out Lamp	7, 8
Paper Release Lever	9
Paper Thickness Lever	9
Paper Size	1, 52
Pitch Selection	8
Platen	8
Platen Release Lever	8
PLOT Address (2200T)	15
PLOT Address (2200VP)	16
PLOT Statement	23
Positive Numbers	55
Power ON/OFF	7
Power ON Home	44
Print Intensity Adjustment	9

Print Wheel, Changing	4
Print Wheel Motion	7
PRINT Statement	19, 26
PRINTUSING Statement	29
Reverse Index	47
Ribbon Cartridge.	4
Ribbon Out	8
Right Movement Switch	6
SELECT CO	21
SELECT LIST	21
SELECT PLOT	19
SELECT PRINT	19
SELECTing the Printer	13
Semicolon (Line Suppression).	28, 33
Specifications	52
Set Home Command	44
Set Left Margin	33
Set Line Feed Spacing	37
Set TAB	49
Suppressing Carriage Return	28, 33
\$GIO	61
TAB(); Function	30
TAB HEX Code	45
Temperature	53
Top-Of-Form Code	47
Top-Of-Form Switch	8
Turn-on Procedure	54
Trailing Spaces HEX(20)	59
2's Complement	55
Underscore	50
Unit Address	16
Unpacking	2
Uppercase Operations.	7
Vertical TAB Code	46
Vertical TAB	46, 51
Zoned Format with Commas	26, 27

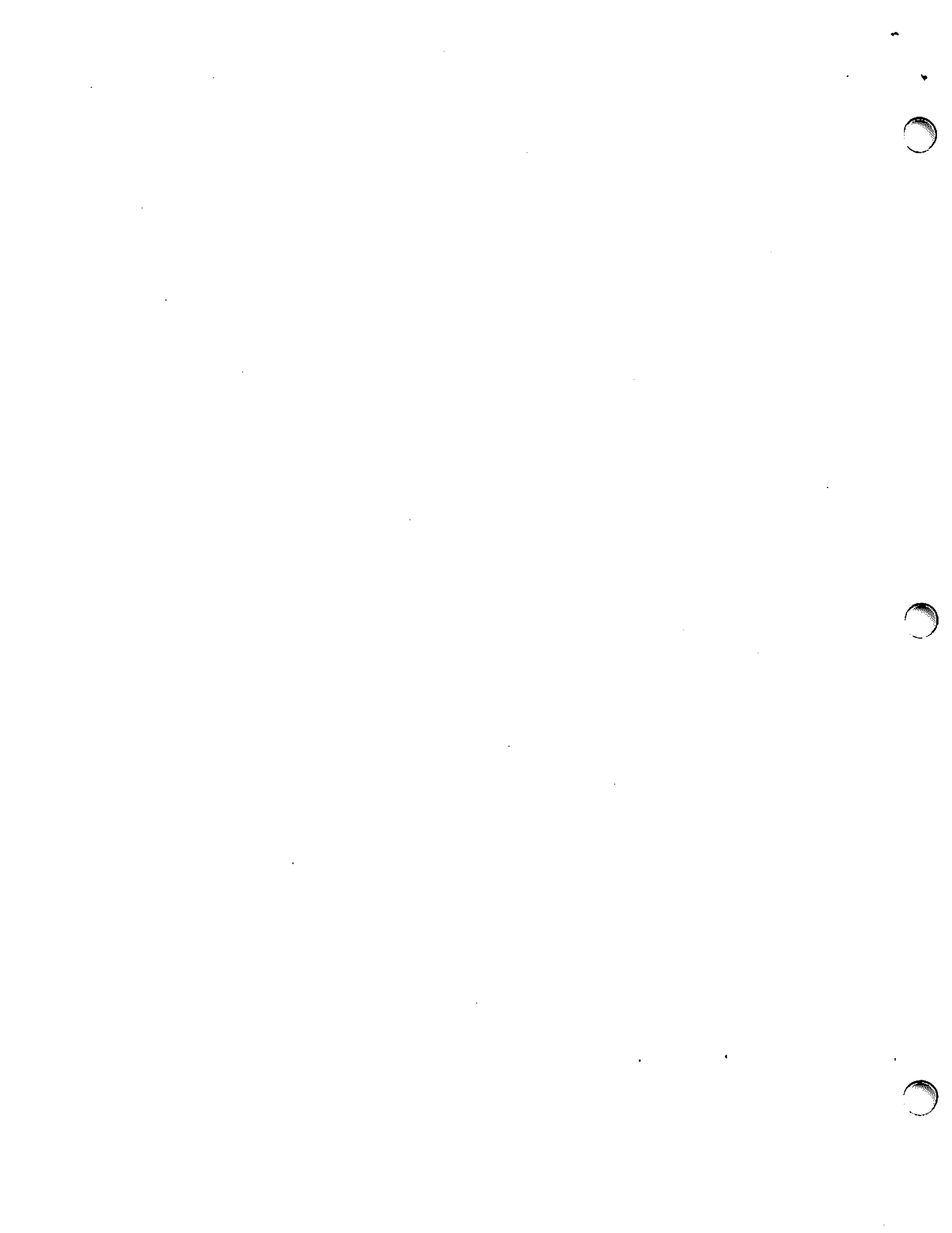

To help us to provide you with the best manuals possible, please make your comments and suggestions concerning this publication on the form below. Then detach, fold, tape closed and mail to us. All comments and suggestions become the property of Wang Laboratories, Inc. For a reply, be sure to include your name and address. Your cooperation is appreciated.

700-5744

TITLE OF MANUAL 2281W Printer/Plotter User Manual

COMMENTS:

Fold

Fold



Fold

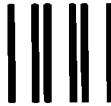

FIRST CLASS
PERMIT NO. 16
Lowell, Mass.

BUSINESS REPLY MAIL
NO POSTAGE STAMP NECESSARY IF MAILED IN THE UNITED STATES

— POSTAGE WILL BE PAID BY —

WANG LABORATORIES, INC.
ONE INDUSTRIAL AVENUE
LOWELL, MASSACHUSETTS 01851

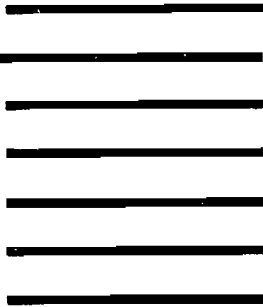

Cut along dotted line.

Attention: Technical Writing Department

Fold



United States

Alabama Birmingham Mobile	Florida Miami Hialeah Jacksonville Orlando Tampa	Louisiana Baton Rouge Metairie	New Hampshire Manchester	Oregon Eugene Portland	Vermont Montpelier
Alaska Anchorage	Georgia Atlanta Savannah	Maryland Rockville Towson	New Jersey Toms River Mountainside Clifton	Pennsylvania Allentown Camp Hill Erie Philadelphia Pittsburgh Wayne	Virginia Newport News Norfolk Richmond
Arizona Phoenix Tucson	Hawaii Honolulu	Massachusetts Billerica Boston Burlington Chelmsford Lawrence Littleton Lowell Tewksbury Worcester	New Mexico Albuquerque	Rhode Island Cranston	Washington Richland Seattle Spokane Tacoma
California Culver City Fountain Valley Fresno Inglewood Sacramento San Diego San Francisco Santa Clara Ventura	Idaho Idaho Falls	Michigan Kentwood Okemos Southfield	New York Albany Buffalo Fairport Lake Success New York City Syracuse	South Carolina Charleston Columbia	Wisconsin Brookfield Madison Wauwatosa
Colorado Englewood	Illinois Chicago Morton Park Ridge Rock Island Rosemont	Minnesota Eden Prairie	North Carolina Charlotte Greensboro Raleigh	Tennessee Chattanooga Knoxville Memphis Nashville	
Connecticut New Haven Stamford Wethersfield	Indiana Indianapolis South Bend	Missouri Creve Coeur	Ohio Cincinnati Cleveland Middleburg Heights Toledo Worthington	Texas Austin Dallas Houston San Antonio	
District of Columbia Washington	Kansas Overland Park Wichita	Nebraska Omaha	Oklahoma Oklahoma City Tulsa	Utah Salt Lake City	
	Kentucky Louisville	Nevada Las Vegas Reno			

International Offices

Australia Wang Computer Pty., Ltd. Adelaide, S.A. Brisbane, Qld. Canberra, A.C.T. Darwin N.T. Perth, W.A. South Melbourne, Vic 3 Sydney, NSW	France Wang France S.A.R.L. Paris Bordeaux Lyon Marseilles Nantes Strasbourg Toulouse	Singapore Wang Computer (Pte) Ltd. Singapore
Austria Wang Gesellschaft, m.b.H. Vienna	Great Britain Wang (U.K.) Ltd. Richmond Birmingham London Manchester Northwood Hills	Sweden Wang Skandinaviska AB Stockholm Gothenburg Malmo
Belgium Wang Europe, S.A. Brussels Erpe-Mere	Hong Kong Wang Pacific Ltd. Hong Kong	Switzerland Wang A.G. Zurich Basel Geneva
Canada Wang Laboratories (Canada) Ltd. Burnaby, B.C. Calgary, Alberta Don Mills, Ontario Edmonton, Alberta Hamilton, Ontario Montreal, Quebec Ottawa, Ontario Winnipeg, Manitoba	Japan Wang Computer Ltd. Tokyo	Wang Trading A.G. Zug
China Wang Industrial Co., Ltd. Taipei Wang Laboratories Ltd. Taipei	Netherlands Wang Nederland B.V. IJsselstein Gronigen	United States Wang International Trade, Inc. Lowell, Mass.
	New Zealand Wang Computer Ltd. Auckland Wellington	West Germany Wang Laboratories, GmbH Frankfurt Berlin Cologne Dusseldorf Essen Freiburg Hamburg Hannover Kassel Munich Nurnberg Saarbrucken Stuttgart

International Representatives

Abu-Dhabi Argentina Bahrain Bolivia Brazil Canary Islands Chile Colombia Costa Rica Cyprus Denmark Dominican Republic Ecuador Egypt El Salvador Finland Ghana Greece Guatemala Haiti Honduras Iceland India Indonesia Ireland Israel Italy Jamaica Japan Jordan	Kenya Korea Kuwait Lebanon Liberia Malaysia Malta Mexico Morocco Nicaragua Nigeria Norway Paraguay Peru Phillippines Portugal Saudi Arabia Scotland Spain Sri Lanka Sudan Syria Thailand Turkey United Arab Emirates Venezuela
--	--

WANG

LABORATORIES, INC.

ONE INDUSTRIAL AVENUE, LOWELL, MASSACHUSETTS 01851, TEL. (617) 459-5000, TWX 710 343-6789, TELEX 94-7421

Printed in U.S.A.
700-5744
12-79-2.5M
Price: see current list