

WANG

MODEL 9005  
PAPER TAPE PUNCH  
USER MANUAL

# SYSTEM 2200

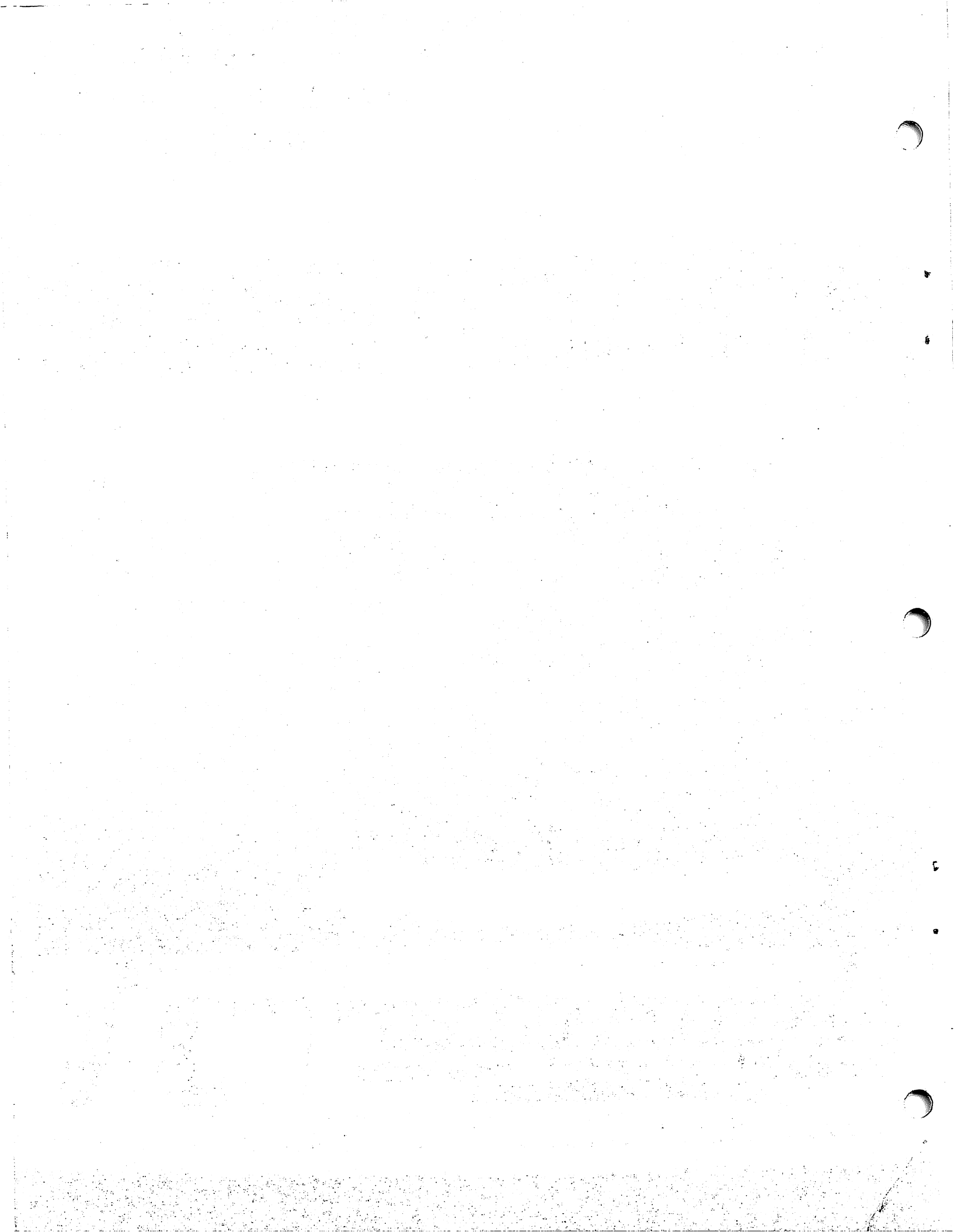



# MODEL 9005 PAPER TAPE PUNCH USER MANUAL

© Wang Laboratories, Inc., 1978



LABORATORIES, INC.

---

ONE INDUSTRIAL AVENUE, LOWELL, MASSACHUSETTS 01851, TEL. (617) 851-4111, TWX 710 343-6769, TELEX 94-7421

## **Disclaimer of Warranties and Limitation of Liabilities**

The staff of Wang Laboratories, Inc., has taken due care in preparing this manual; however, nothing contained herein modifies or alters in any way the standard terms and conditions of the Wang purchase agreement, lease agreement, or rental agreement by which this equipment was acquired, nor increases in any way Wang's liability to the customer. In no event shall Wang Laboratories, Inc., or its subsidiaries be liable for incidental or consequential damages in connection with or arising from the use of this manual or any programs contained herein.

**WANG**

LABORATORIES, INC.

ONE INDUSTRIAL AVENUE. LOWELL, MASSACHUSETTS 01851. TEL. (617) 851-4111, TWX 710 343-6769, TELEX 94-7421

## HOW TO USE THIS MANUAL

This manual provides answers to questions concerning the operation of the Model 9005 Paper Tape Punch. It is designed for users who are already familiar with the available Wang System and its BASIC language.

For users who are not familiar with the operation of their system, it is recommended that the Programming in BASIC Manual and the Wang BASIC Language Reference Manual be read before proceeding with this manual.

This manual has been divided into two chapters covering all the operational features of the Paper Tape Punch. Chapter 1 contains general information about the Model 9005. Chapter 2 demonstrates the use of BASIC control statements and how to format data. Hexadecimal codes and the Model 9005 specifications are collected in the appendices.

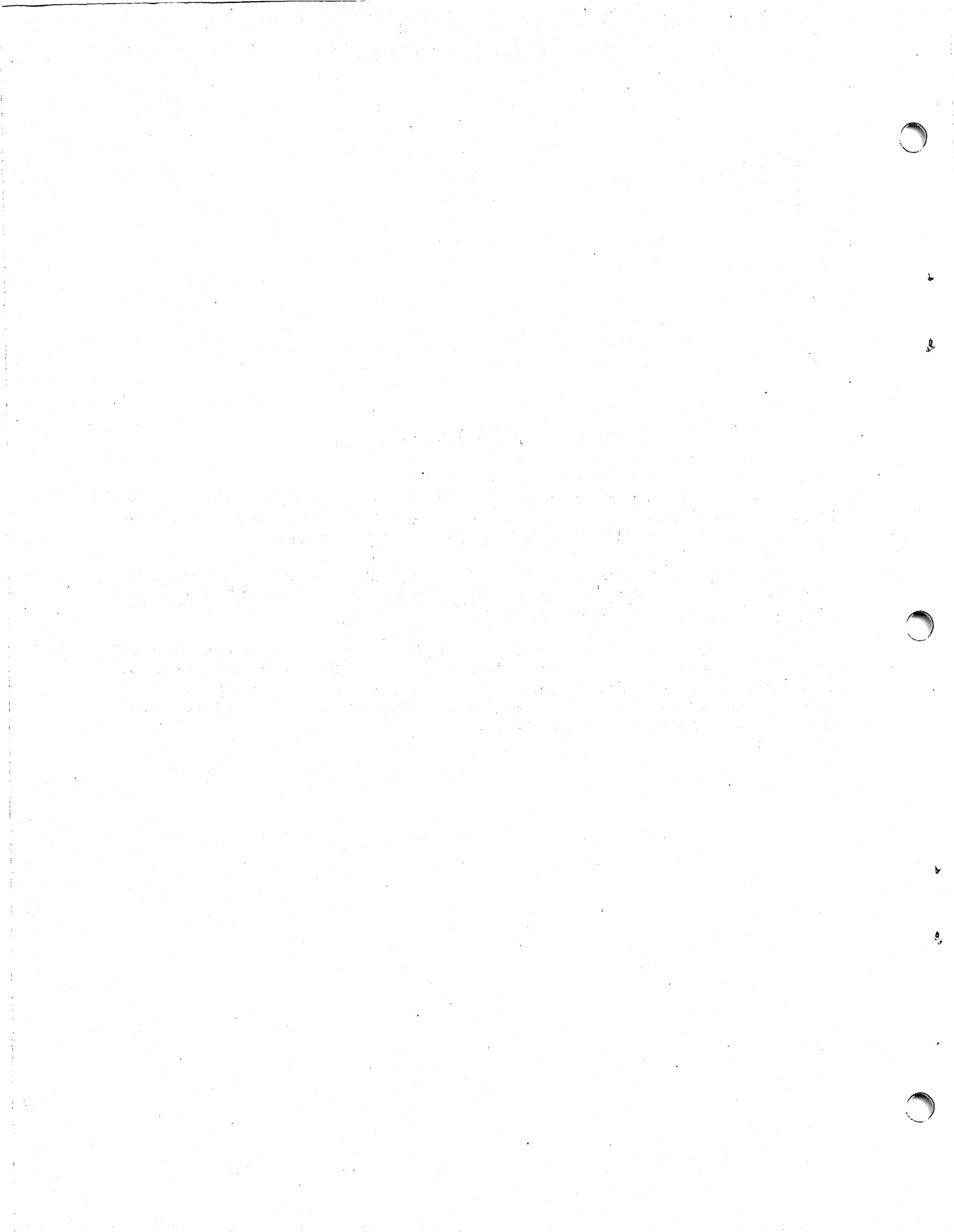

# TABLE OF CONTENTS

	PAGE
CHAPTER 1	
GENERAL INFORMATION . . . . .	1
1.1 Introduction . . . . .	1
1.2 Unpacking and Installation. . . . .	2
1.3 Model 9005 Features . . . . .	2
1.4 The Paper Tape. . . . .	5
1.5 ASCII Code Information . . . . .	6
1.6 Model 9005 and System TURN-ON . . . . .	7
1.7 Paper Tape Insertion . . . . .	8
CHAPTER 2	
OPERATION . . . . .	9
2.1 Recommended 2200 Systems. . . . .	9
2.2 Samples of BASIC Commands . . . . .	10
2.3 Programming Techniques for Formatting and Data Conversion . . . . .	24
2.4 Diagnostics . . . . .	25
APPENDICES	
APPENDIX A - Hexadecimal and Binary Codes. . . . .	26
APPENDIX B - Specifications. . . . .	27
PREVENTIVE MAINTENANCE INFORMATION . . . . .	28
INDEX . . . . .	29

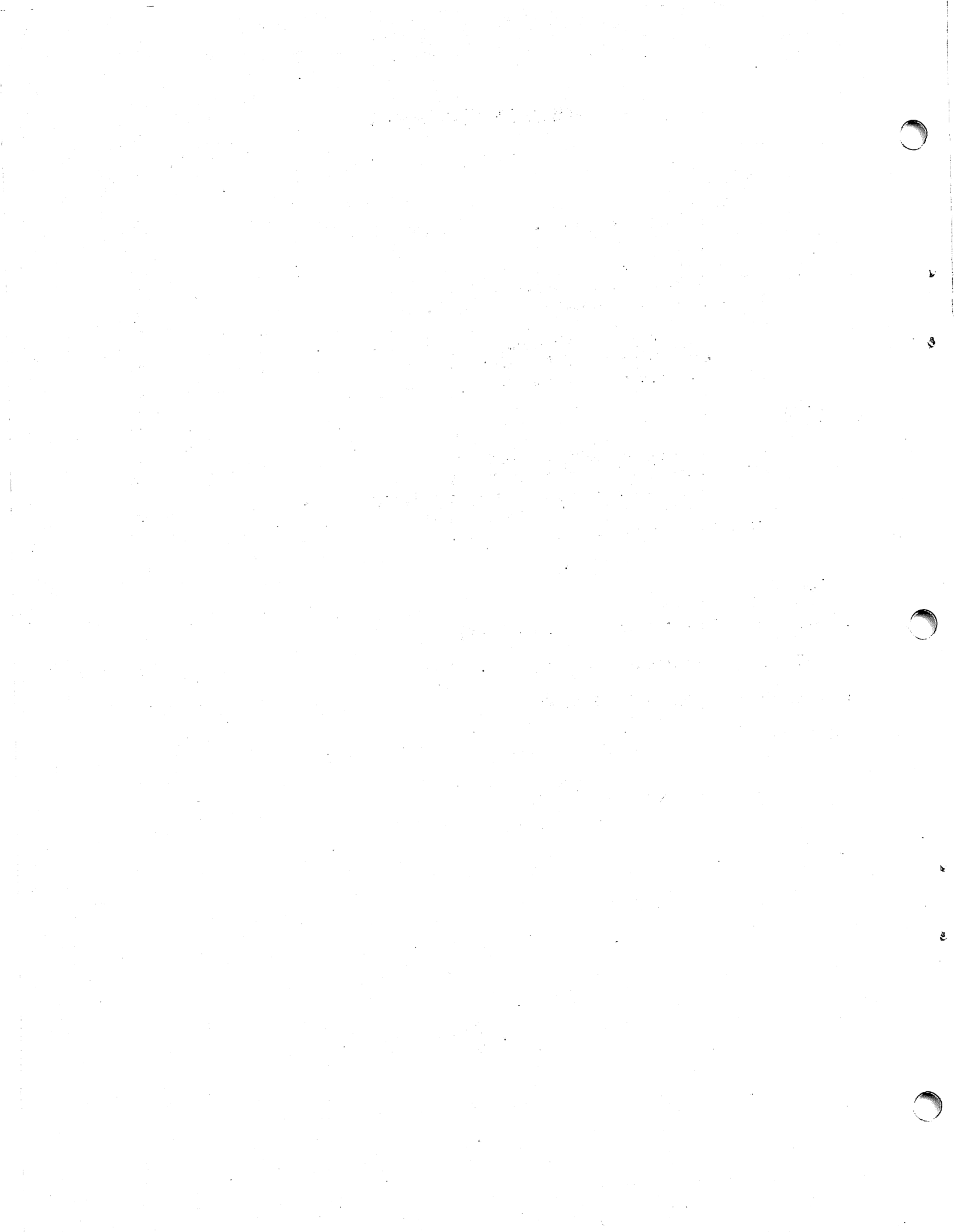



# CHAPTER 1

## GENERAL INFORMATION

### 1.1 INTRODUCTION

This manual describes the characteristics and operations of the Model 9005 Paper Tape Punch (see Figure 1-1). The Model 9005 can punch up to 1000 feet of tape at 50 characters-per-second in 5, 6, 7, or 8 level code. Tape widths ranging from 11/16 inch (1.7 cm) to 1 inch (2.54 cm) can be used, providing 5 through 8 channels of data information.

The Model 9005 is interfaced to WANG's 2200 or WCS-20 and WCS-30 Series Computer Systems. Interface between the Central Processing Unit (CPU) and the punch is accomplished by means of an interface cable, one end of which is plugged into a Paper Tape Punch Controller and the opposite end plugged into the Model 9005 Punch.

The punch responds to signals generated by the CPU to encode information on tape by perforating it. Any one of eight-code channel punches can be raised by energizing its associated amplifier and punch solenoid, and any acceptable combination of punches can be activated.

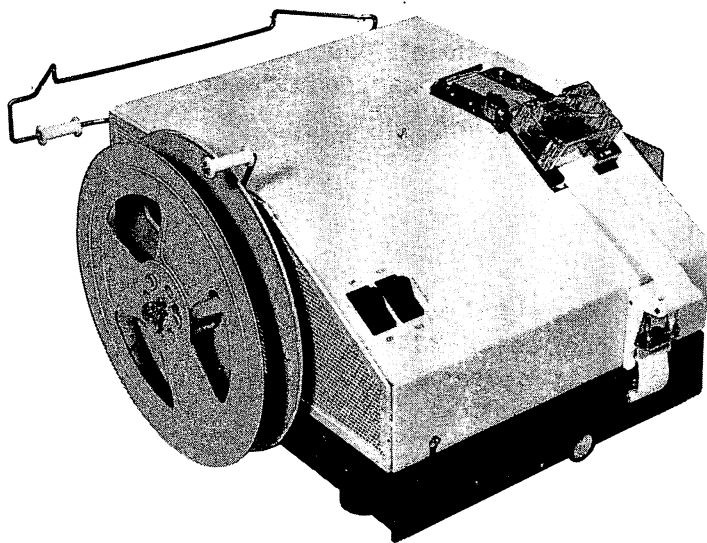

Figure 1-1. Model 9005 Paper Tape Punch

The punch processes tape only in the forward direction. Tape is installed by opening the cover, positioning the tape over the tape guide and sprocket and through the slot in the tape tear plate and closing the cover. If the optional positioning knob is installed, tape is inserted onto the sprocket and the knob turned until tape emerges from the cover and tape tear plate (see Figure 1-2).

An adjustable guide at the front end of the punch can be set to correspond to the width of the tape being processed. If tape narrower than one inch is to be used, the guide must be preset to maintain contact with the right-hand edge of the tape.

The punch normally operates at a maximum speed of 50 characters-per-second. The actual speed of data encoding, however, depends upon the speed at which the central processor sends information to the punch.

## 1.2 UNPACKING AND INSTALLATION

When you receive your equipment, notify your Wang Service Representative; he should unpack and set up your Paper Tape Punch. Failure to notify your Wang Service Representative will void your warranty.

To install the Model 9005, your Wang Service Representative uses the following procedure:

1. The device address switch on the Paper Tape Punch Controller board is set to HEX(38). The board is installed in the CPU chassis of your system.
2. Using the interface cable, the 36-pin amphenol connector of the cable is plugged into the installed controller board. The lock chips are set on the controller board in the up (locked) position; the opposite end of the cable is plugged into the Model 9005.
3. The power cord from the Model 9005 must be plugged into a grounded (3-prong) wall outlet (see power requirements in Appendix B).

## 1.3 MODEL 9005 FEATURES

### Transparent Cover

The cover keeps the tape in contact with the sprocket and the platen surface. Transparency of the cover allows the operator to observe the tape after it comes to rest and, if necessary, to read data codes without having to remove tape from the punch.

The cover is held down with a latch, shown in Figure 1-2, that locks it in place. The latch is released by manually moving the latch release sideways and away from the cover.

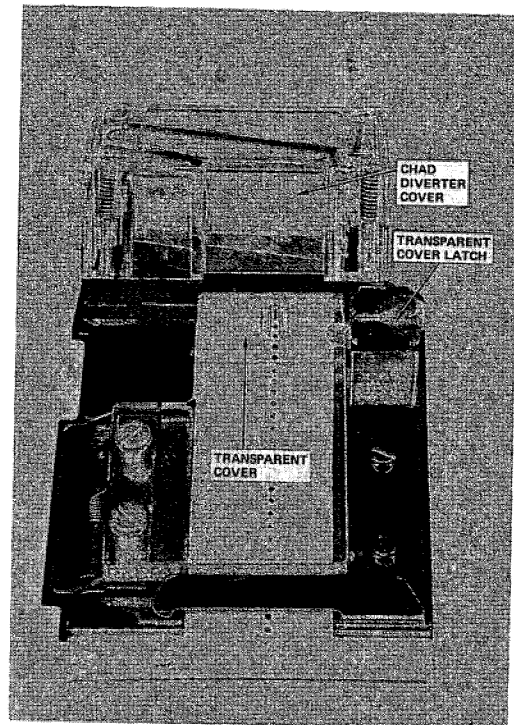
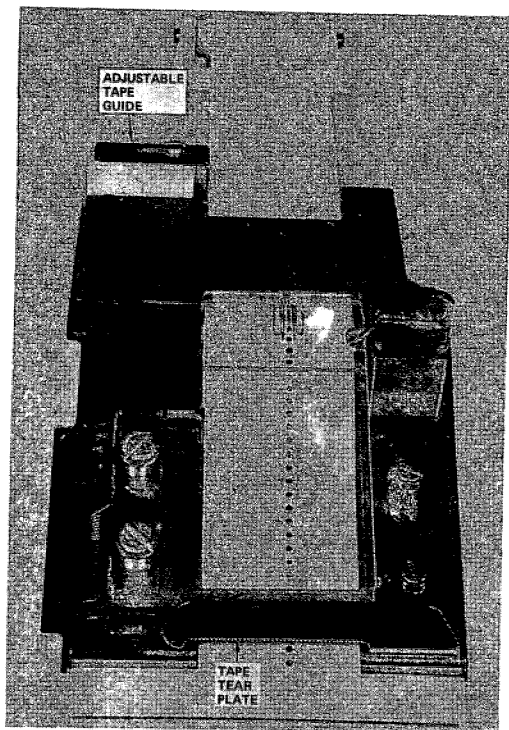

Figure 1-2. Basic Punch, Definition of Terms

### Tape Tear Plate

The plate is mounted on the platen below the cover so that its toothed or serrated section adjoins the edge of the cover. The serrations provide the cutting surface necessary to tear tape cleanly along a line perpendicular to that of normal tape motion. The plate also guides the left-hand edge of the tape which moves below the tape plate. The operator must pull the tape up and against the tear plate to tear off a section.

### Adjustable Tape Guide

The guide is mounted to the upper die plate and consists of a metal plate that guides the right-hand edge of the tape. The operator positions the guide to correspond to the width of tape being processed, then locks the guide in place with the screw. The guide is located at the front of the punch and is used only to correctly guide tape into punch.

### Chad Diverter And Tube

Chad (paper tape by-product from the punch pins) collects in the chad diverter and is expelled through the chad tube into the chad container. The chad container holds chad from approximately 1,000 feet of punched tape.

To empty the chad container, grasp it by the top and bottom edges, lift it up and then out. The chad container is connected to the side of the punch by a simple screw mount. To replace the container, reverse the process, making sure the chad tube does not become dislodged.

### Tape Movement

The tape drawer has storage space for a tape roll. A tape rewinder is mounted to the left side of the unit. A tape tension and out-of-tape switch at the right front of the unit allows tape to be monitored so that punch operation can be stopped before tape tears if a tight tape condition should occur. During normal operation, tape unspools from within the drawer and passes through the tape tension and out-of-tape switches into the punch. When the tape emerges from the punch, it slips over a guide bar supported by the cover and winds around the idler arm of the rewinder, back over the idler roller of the guide bar, and onto the tape reel. Data channels and tape motion are illustrated below.

#### CHANNEL IDENTIFICATION

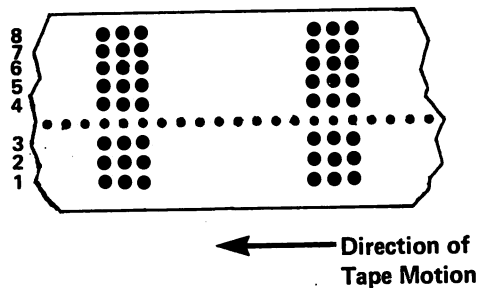

### Punch Cover

The punch cover encloses the entire unit except the top section of the punch, the bottom drawer, the tape tension switch, the tape rewinder, and a connector and fuse at the rear of the unit. The cover should only be removed by a Wang Service Representative.

#### 1.4 THE PAPER TAPE

Model 9005 handles paper or mylar tape only. The paper tape mechanism is equipped with an easily adjustable tape guide that provides a right-hand support for the tape to prevent it from skewing during in-feed operations.

Tape widths ranging from 11/16 inch to 1 inch can be used, providing 5 through 8 channels of data information. The punch accepts signals by energizing its punch solenoids to drive corresponding punch pins through the tape.

Table 1-1 shows different paper punch tape specifications. Oiled paper tape is recommended because it affords maximum punch life. Dry paper tape or a paper/mylar laminate may be used occasionally (up to 10% of total punch operating time). Metalized mylar tape is NOT recommended for punch operations.

Standard 8-channel, one-inch paper tape, as well as narrower tapes, must conform to the following specifications:

1. The sprocket holes must conform to the pin feed mechanism, which handles ten sprocket holes per inch.
2. The sprocket holes must align with the data holes (IN-LINE).
3. The ratio between the diameter of the sprocket hole and the diameter of the data hole must conform to punched tape standards (EIA standard RS-227).

Table 1-1. Tape Size, Composition, and Use.

COMPOSITION	PUNCH USE TIME	WIDTH (IN.)	LENGTH (FT.)	THICKNESS (IN.)
Oiled Paper	100%	11/16	8 in. dia.	0.008
Dry Paper	10%	7/8	rolls	max
Mylar/Paper*	10%	or 1	max 1000 ft.	spliced

\* Vacuum deposit or metal foil type should not be used.

Standard teletypesetters use coded, 6-channel, punched paper tape 7/8 inch or 1 inch wide. The paper tape may have advanced feed holes (the leading edge of the feed hole is aligned with the leading edge of the code hole) or in-line feed holes which are aligned with the center of the code hole. The feed holes must be 7/16 inch (0.4375 inch) from the guide edge of the tape; thus, on a 7/8 inch wide tape, the feed holes are centered in the tape. The Model 9005 has an IN-LINE punch head.

### 1.5 ASCII CODE INFORMATION

ASCII character code is a standard coding system in which each number, letter, and symbol in the ASCII character set is assigned a unique, 8-bit binary code (although, in fact, only 7 bits are actually used for the code since the eighth-bit is reserved in ASCII for parity). In the System 2200, the 8-bit is automatically set equal to zero when read in under LOAD and DATALOAD control; it is actually read only under DATALOAD BT control (See Wang Basic Language Reference Manual). This 8-bit binary code is, in turn, translated into a pattern of punches on paper tape.

Consider the following section of a paper tape:

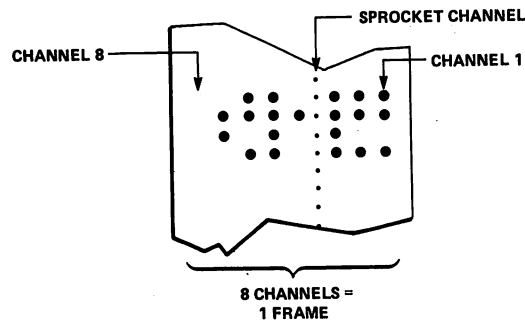

ASCII is expressible as a 2-digit HEX number. The HEX number has the form HEX(hh) where h = a hex digit 0 to 9 or a letter A to F. In dealing with ASCII codes, it is more efficient to refer to the 2-digit HEX code for a particular character than its equivalent, 8-bit binary code.

The 2-digit HEX code for each frame of tape is related to the 8-bit binary code as follows:

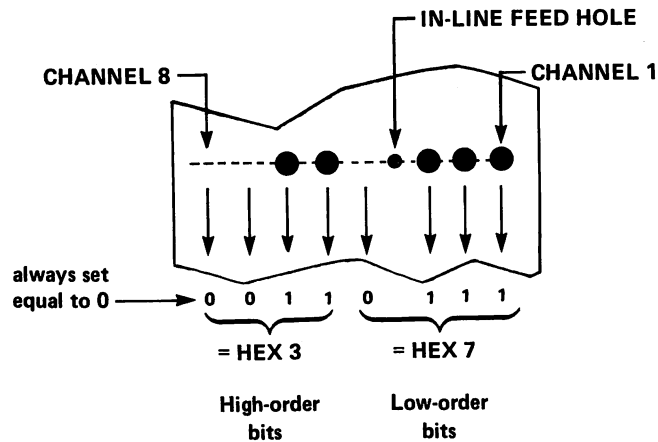

The right 4-bits of each 8-bit binary value (tape channels 1-4) are the "low-order" bits and are represented by the right digit of the 2-digit HEX code. The left 4-bits (channels 5-8) are represented by the left digit of the HEX code; they are called the "high-order" bits. The binary value in the above frame, then, is expressed in HEX shorthand as 37. HEX 37, like its binary equivalent  $00110111_2$ , is the code for ASCII 7. When reading a tape, convert each frame into a HEX code corresponding to the desired character (see Appendix A for the ASCII character set). The letter K, for example, is assigned the binary code  $01001011_2$  (HEX 4B) in ASCII. The figure below shows a frame punched with the letter K.

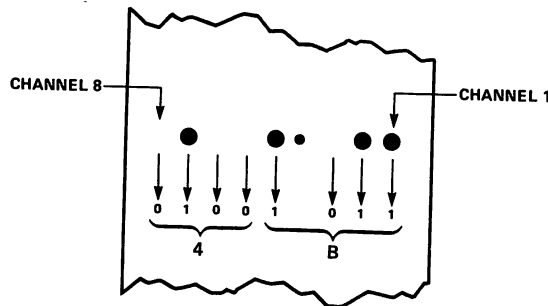

## 1.6 MODEL 9005 AND SYSTEM TURN-ON

1. Verify that all power cords are connected to a source of electrical power and all peripheral cables are connected to your Wang system CPU.
2. Turn on all power switches. When the Wang system is turned on, Master Initialization occurs, i.e., memory is cleared of all programs and variables and the addresses of primary devices are set to their default values. Master Initialization automatically selects the CRT as the printing device. The device address for the Model 9005 must be specified in the appropriate tape control statement (see Chapter 2).
3. The ON/OFF rocker switch controls the power to the punch. To turn the punch ON, press the ON rocker switch.

## 1.7 PAPER TAPE INSERTION

To load the paper tape, refer to Figure 1-3 and complete the following steps:

1. Place a supply reel of tape in the tape drawer so that the roll turns counterclockwise when unwinding and extend the tape over the tape tension arm roller (B).
2. Place the tape through the drawer slot (C) beneath the roller and close the drawer.
3. Thread the tape through the tape tension switch (D), outside the roller, and into the punch die assembly (E). Open the plastic cover to thread the tape past the punch head.
4. Place the ON/OFF switch (F) in the ON position. Depress the FEED switch (G) and apply slight pressure on the tape in a forward direction to carry the tape into the feeding mechanism and out of the tape deflector.
5. Use a leader of about 30 inches and thread the tape around the guide (H) and the roller (I) and then into the take-up reel. The unit now is ready for operation.

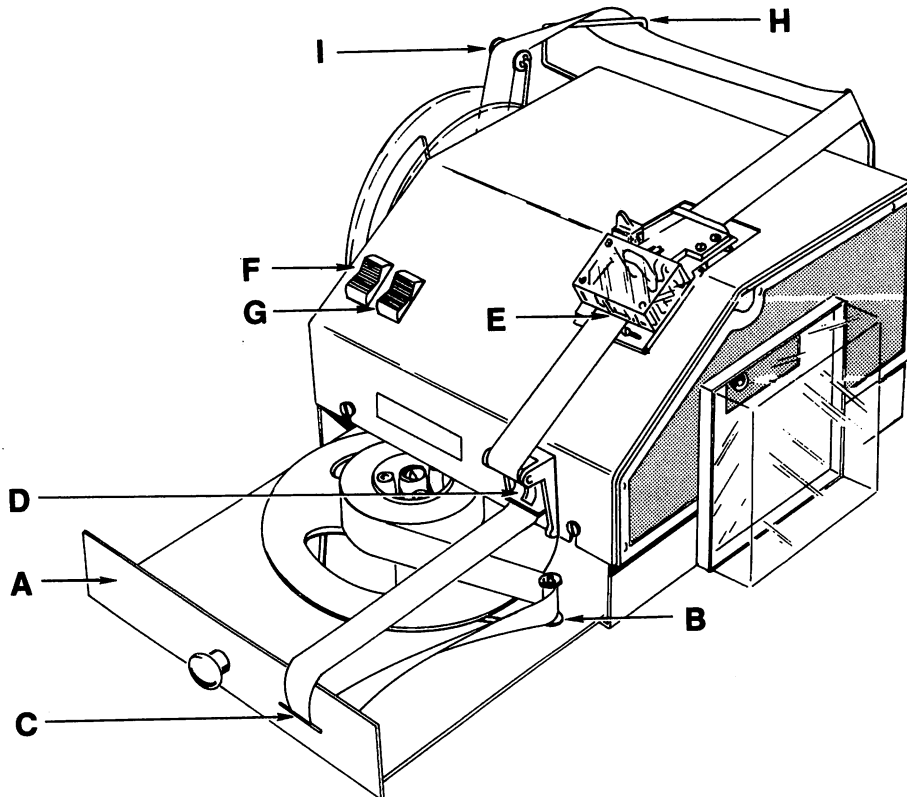

Figure 1-3. Loading Paper Tape



## CHAPTER 2 OPERATION

### 2.1 RECOMMENDED 2200 SYSTEMS

For overall use of the Model 9005, a System 2200B, 2200C, 2200T or 2200VP is recommended. These systems support the following tape control statements.

1. PRINT - (Data Punching)
2. PRINTUSING - (Data Punching)
3. DATASAVE (TELETYPE PUNCH) - (2200 Data Record Punching)
4. DATASAVE BT (TELETYPE PUNCH) - (Data Punching)
5. SAVE (TELETYPE PUNCH) - (Program Punching)

If option 2 is available in the 2200B or 2200C, the use of the \$TRAN statement in this option makes code conversion more efficient. Also, the BIN and CONVERT statements available in the 2200B, 2200C, and 2200T can be used in many cases.

In cases where the primary requirement of the Model 9005 is the preparation of specialized data tapes (and not punching programs or data records which can be read back by the Model 2203 Punched Paper Tape Reader) a 2200S could be used to support the punch unit.

The system 2200S provides:

1. PRINT - (Data Punching)
2. PRINTUSING - (Data Punching)

**NOTE:**

A 2200A System is not recommended to support the punch because it does not have the BIN or CONVERT statements.

## 2.2 SAMPLES OF BASIC COMMANDS

The following Wang BASIC commands are valid with the Model 9005:

DATASAVE - Punches Paper Tape Data

DATASAVE BT - Punches Paper Tape

SAVE - Punches Paper Tape Program Text

PRINT - Output

HEXPRINT - Output

PRINTUSING - Output

A description of each of these BASIC commands follows.

# DATASAVE

General Form:

```
DATASAVE [ #f, ] { OPEN "name"
              /4yy, } END
              argument [, argument] ... }
```

where

#f = File number assigned to unit by SELECT statement (f is an integer from 1 to 6).

4yy = Device address of Paper Tape Punch (438).

if neither of the above is specified, the default device address (the device address currently assigned to TAPE) is used.

argument = { literal string  
alpha variable  
expression  
array designator }

name = 1 to 8 characters (note, the name is required but is not used).

OPEN = Punch leader code (50 null characters).

END = Punch X-OFF character and trailer code (50 null characters).

The DATASAVE statement causes the values specified in the argument list to be punched on paper tape. Numeric values are written in a form identical to that resulting from a PRINT statement (i.e., exponential or fixed point form).

Alphanumeric values are written identically to the character string data they contain; trailing spaces in values of alphanumeric variables are not written. Alphanumeric values must not contain any of the following characters: CR, RUBOUT, X-OFF, null. The OPEN parameter writes leader code (50 null characters). The END parameter terminates the data file by punching an X-OFF character and trailer code (50 null characters).

The paper tape is punched in the following format:

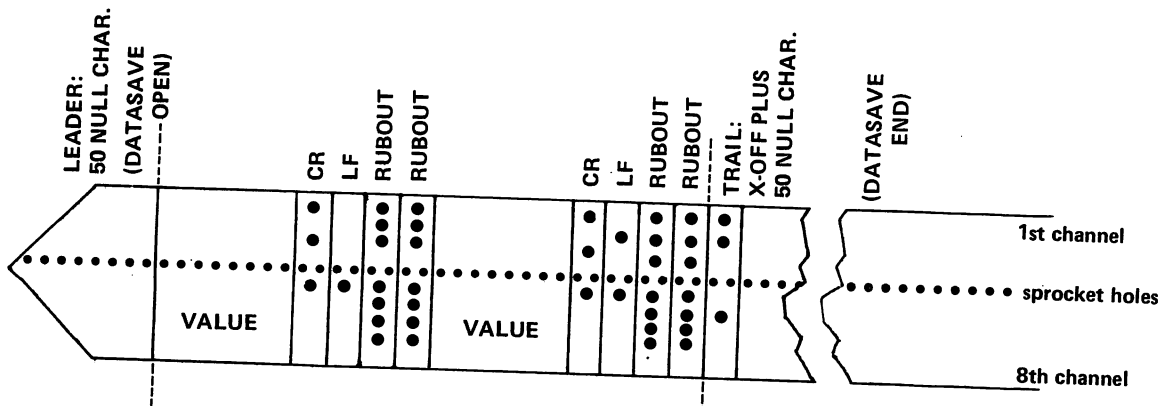

**EXAMPLE:**

```
DATASAVE X, Y, A$  
DATASAVE OPEN "TTY"  
DATASAVE END  
DATASAVE #1 A$()  
DATASAVE /438, N(), A$, X Y, Z  
DATASAVE STR(A$, I, J), HEX(FAFB)
```

## DATASAVE BT

General Form:

DATASAVE BT  $\left[ \begin{array}{l} \#f, \\ /4yy, \end{array} \right] \left\{ \begin{array}{l} \text{alpha variable} \\ \text{alpha array designator} \end{array} \right\}$

where  $\#f$  = Logical file number assigned to unit by SELECT statement (f is an integer from 1 to 6).

$4yy$  = Device address of Paper Tape Punch (438)

If neither of the above is specified, the default device address (the device address currently assigned to TAPE) is used.

The DATASAVE BT statement punches the values of an alpha variable or alpha array onto a paper tape with no control information (i.e., no CR, LF, RUBOUT RUBOUT separating values). Trailing spaces in alpha values are punched.

DATASAVE BT permits paper tapes to be punched in any format. Any 8-bit codes may be punched.

### EXAMPLE:

```
DATASAVE BT #2, A$( )
DATASAVE BT /438, B1$( )
DATASAVE BT Q$( )
```

## SAVE

General Form:

SAVE [ #f, ] [ line number [ ,line number ] ]  
          /4yy, ]

where

#f = File number assigned to unit by SELECT statement  
(f is an integer from 1 to 6).

4yy = Device address of Paper Tape Punch (438).

If neither of the above is specified, the  
default device address (the device address  
currently assigned to TAPE) is used.

1st line number = Starting line number to be saved.

2nd line number = Ending line number to saved.

The SAVE command causes the BASIC program (or portions of BASIC programs) to be punched on paper tape.

If no line numbers are specified, the entire user program text is saved. SAVE with one line number causes all user program lines from the indicated lines through the highest-numbered program line to be punched on tape. If two line numbers are entered, all text from the first through the second line number, inclusive, is punched.

The paper tape format is shown below:

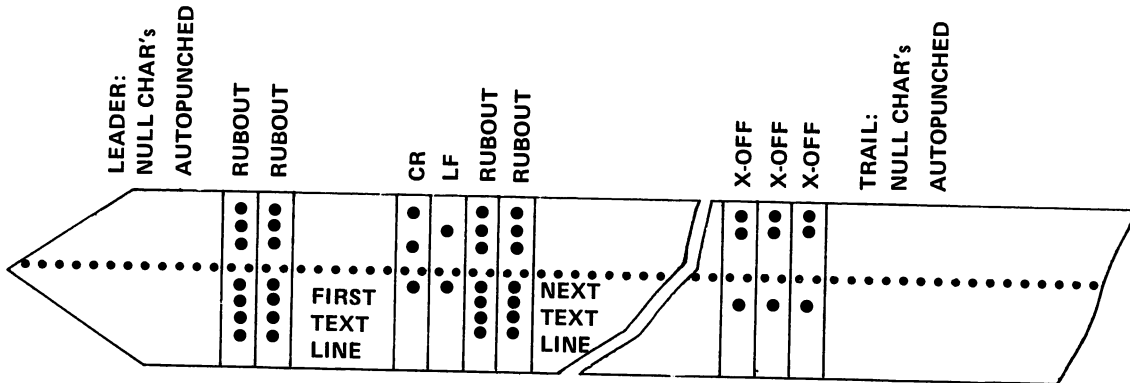

Text lines are punched in ASCII character code and are separated by CR LF RUBOUT RUBOUT. The program is terminated by three X-OFF's.

**EXAMPLES:**

```

SAVE
SAVE #3
SAVE /438
SAVE /438, 100, 200
SAVE #3, 400

```

**SELECT Statement**

The SELECT statement must be used by the operator to select the Model 9005 as the output device when using PRINT, HEXPRINT or PRINTUSING statements to transmit data to the paper punch. A SELECT statement can be used either in the Immediate mode or as a statement within a program. When used with the Model 9005, the syntax of the SELECT statement requires that it contain the BASIC verb PRINT and a 3-hexdigit device code (xyy) consisting of a Device Type (x) and a Unit Address code (yy).

**EXAMPLE:**

```

100 SELECT PRINT 438
Device Type _____▲
Unit Address _____▲

```

The Device Type digit (x) denotes to the 2200 CPU how to handle end-of-line processing. In printing operations, automatic end-of-line processing occurs when a carriage return code (HEX(0D)) is detected in the program or when the line character count reaches the line length specified for the device. Table 2-1 describes the Device Type codes used for data output. Device Type code 4 is used with the Model 9005.

The Unit Address (yy) of the Model 9005 controller is preset to 38 by the Wang Service Representative and must be the address used in SELECT statements dealing with the paper punch.

Table 2-1. Device Type Codes

DEVICE TYPE (x)	END-OF-LINE CHARACTERS	LENGTH CODE SPECIFIED	EXPLANATION
0	CR, LF	1 - 256 or DEFAULT LENGTH	The end-of-line processing issues a carriage return and a line feed.
2	CR, 00	Same As Above	The end-of-line processing issues a carriage return and a HEX 00 (NULL).
4	None	None	The line character count is suppressed in determining end-of-line processing.

PRINT, HEXPRINT

The PRINT and HEXPRINT verbs can be used to transmit data to the Model 9005. A PRINT statement is output in ASCII format; the HEXPRINT statement is output in HEXADECIMAL format.

Examples:

```
:10 SELECT PRINT 438
:20 PRINT "ABCD"
```

```
:10 SELECT PRINT 438
:15 A$ = "PAPER PUNCH"
:20 HEXPRINT A$
```

HEX Function

The HEX function is used in a BASIC program to output characters on the Model 9005 (both those that do appear and do not appear on the standard keyboard) and to output printing control codes. The HEX function has the form control codes. The HEX function has the form control codes. The HEX function has the form

```
HEX(hh [hh] [. .] .)
```



Where h = a hexdigit 0 to 9 or a letter A to F. An even number of hexdigits must always appear in a HEX function; spaces are not allowed. HEX codes for characters and/or printing control can be combined. For example

```
:10 SELECT PRINT 438
:20 PRINT HEX(410DOA42)
: RUN(EXECUTE)
```

produces the 8-bit codes for:

```
A
CR
LF
B
```

When run, since 'A' is HEX(41), 'carriage return' is HEX(OD), 'line feed' is HEX(OA), and 'B' is HEX(42). (See Appendix A).

## PRINTUSING

General Form: PRINTUSING line number [, print element] [t print element]... [;]

where line number = Line number of the corresponding  
IMAGE (%) statement.

print element = { expression  
alpha or numeric variable  
literal string in double quotes }

t = Comma or semicolon.

The PRINTUSING statement permits numeric and alphanumeric values to be printed in a formatted fashion on the output device currently selected for PRINT.

PRINTUSING operates in conjunction with a referenced IMAGE statement. Print elements in the PRINTUSING statement are edited into the print line as directed by the IMAGE statement. Each print element is edited, in the order of its appearance in the PRINTUSING statement, into a corresponding format in the IMAGE statement. The IMAGE statement provides both alphanumeric text to be printed between the inserted print elements and the format specifications for the inserted print element. The format for each numerical print element is composed of # characters to specify digits and, optionally, +, -, , , and \$ characters to specify sign, decimal point, exponent, and edit characters. If the number of print elements exceeds the number of formats in the IMAGE statement, a carriage return/line-feed occurs, and the IMAGE statement is reused from the beginning for the remaining print elements (see Example 2). In Example 2, the carriage return/line-feed may be suppressed by replacing the comma between print elements with a semicolon. The results are shown in Example 3.

The carriage return/line-feed normally occurs at the end of the execution of a PRINTUSING statement and can also be suppressed by placing a semicolon at the end of the PRINTUSING statement (Example 4). PRINTUSING may not be used in the Immediate mode.

### Example 1:

```
:10 X=12.3 : Y=27.123
:20 PRINTUSING 30,X,Y
:30 % ANGLE - ##.## LENGTH = ##.#
:RUN
```

Output: ANGLE = 2.30 LENGTH = 27.1

Example 2:

```
: 5 REM PRINTUSING WITH COMMAS  
:10 X=1: Y=2: Z=3  
:20 PRINTUSING 30,X,Y,Z  
:30 % #.#  
:RUN
```

Output: 1.0  
2.0  
3.0

Example 3:

```
: 5 REM PRINTUSING WITH SEMICOLONS  
:10 X=1: Y=2: Z=3  
:20 PRINTUSING 30,X;Y;Z  
:30 % #.#  
:RUN
```

Output: 1.0 2.0 3.0

Example 4:

```
: 5 REM SEMICOLON AT THE END OF PRINTUSING STATEMENT  
:10 X=1: Y=2: Z=3  
:20 PRINTUSING 30,X,Y,Z;  
:30 % #.#  
:40 PRINT " END"
```

Output:

1.0  
2.0  
3.0 END

## IMAGE

General Form:

$$\% \left\{ \begin{array}{l} \text{format specification} \\ \text{character string} \end{array} \right\} [\dots]$$

character strings cannot contain #'s or colons(:).

Each IMAGE statement format specification has the following general format:

$$\left[ \begin{array}{l} + \\ - \\ \$ \end{array} \right] \# \left[ [ , ] \# \dots \right] \text{ (integer)}$$
$$\left[ \begin{array}{l} - \\ \$ \end{array} \right] \left[ \# \dots [ , ] \# \dots \right] . \left[ \# \dots \right] \text{ (fixed point)}$$
$$\left[ \begin{array}{l} - \\ \$ \end{array} \right] \left[ \# \dots [ , ] \# \dots \right] \left[ . \left[ \# \dots \right] \right] \uparrow\uparrow\uparrow \text{ (exponential)}$$

The image statement variable formats can be classified into three general formats:

FORMAT 1 - Integer            e.g.,###

FORMAT 2 - Fixed Point  
                              Number        e.g.,##.##

FORMAT 3 - Exponential      e.g.,#.## ↑↑↑

Values passed to the IMAGE statement from the corresponding PRINTUSING statement are output according to the format in the IMAGE statement in two forms.

Print elements are formatted according to the following rules:

1. Numeric expression print elements:

- . If the format specification is not started with a plus (+), minus (-), or dollar sign (\$) (i.e., the first format character is a number sign (#) or decimal point (.), and the expression is negative, a minus (-) sign is edited into the print line and the length of the format increased by one character space.

Example 1:

```
:100 PRINTUSING 200, -100.49
:200 % ###.##
:RUN(EXEC)
```

Output:

```
-100.49
```

Example 2:

```
:100 PRINTUSING 200, -0.56
:200 % .##
:RUN(EXEC)
```

Output:

-.56

- If the format specification is started with a plus (+) sign, the sign of the expression (+ or -) is edited into the print line immediately preceding the first significant digit.

Example:

```
:100 PRINTUSING 200, -100.49
:200 % +###.##
:RUN(EXEC)
```

Output:

-100.49

- If the format specification is started with a minus (-) sign, a blank for positive expressions and a minus (-) sign for negative expressions is edited into the print line immediately preceding the first significant digit.

Example:

```
:100 PRINTUSING 200, 100.49
:200 % -###.##
:RUN(EXEC)
```

Output:

100.49

- If the format specification is started with a dollar (\$) sign, a dollar (\$) sign is edited into the print line immediately preceding the first significant digit.

Example:

```
:10 PRINTUSING 20, 100.49
:20 % $###.##
:RUN(EXEC)
```

Output:

\$100.49

- Commas (,) which appear in the integer portion of the format are edited into the print line as they occur, if a significant digit has been edited prior to their occurrence; otherwise, a blank is inserted.

Example 1:  
:10 PRINT USING 20, 1333.33  
:20 % #,###.##  
:RUN(EXEC)

Output:  
1,333.33

Example 2:  
:10 PRINT USING 20, 333.33  
:20 % #,###.##  
:RUN(EXEC)

Output:  
333.33

If the length of the value to be printed is less than the length of the format specification (overformatted), the value is right-adjusted. If the length of the value to be printed is greater than the length of the format specification (underformatted), the format specification is edited into the print line (i.e., #'s are printed instead of number).

Example 1:  
:10 PRINT USING 20, 333.33  
:20 % #,###  
:RUN(EXEC)

Output:  
333

Example 2:  
:10 PRINT USING 20, 1234.56  
:20 % #.#  
:RUN(EXEC)

Output:  
#.# (value too large to format)

The expression value is edited according to the format specified in the IMAGE statement.

FORMAT 1 - The integer part of the value is printed, truncating any fractions. Leading blanks are inserted.

FORMAT 2 - The value is printed as a fixed point number, truncating or extending any fraction with zeros and inserting leading blanks according to the format specification.

FORMAT 3 - The value of the expression is printed as a floating point number. The value is scaled as specified by the format and printed as in formats 1 or 2. (There are, however, no leading blanks.) The exponent is always printed in the 4-character form: E+XX.

2. Alphanumeric string variables or literal string print elements:

The value of a string variable or a literal string in quotation marks is edited into the print line by replacing each character in the format specification with characters in the text string. The text string is left-justified. If the text string is shorter than the format specifications, blanks are inserted on the right.

Example:

```
:10 PRINTUSING 20, "THE END"  
:20 % #####  
:RUN(EXEC)
```

Output:

```
THE END
```

The text string is truncated on the right if it is longer than the format specifications.

Example:

```
:10 PRINTUSING 20, "THE END"  
:20 % #####  
:RUN(EXEC)
```

Output:

```
THE EN
```

## Other PRINTUSING Examples

### Example 1:

```
:100 PRINTUSING 200, 1242.3, 73694.23
:200 % TOTAL SALES = #### VALUE $###,###.##
:RUN(EXEC)
```

Output: TOTAL SALES = 1242 VALUE \$73,694.23

### Example 2:

```
:100 PRINTUSING 200,2.13E-5,2.3E-9
:200 % COEFF = +.### ERROR = -##
:RUN(EXEC)
```

Output: COEFF = +.213E-04 ERROR = 23E-10

### Example 3:

```
:100 PRINTUSING 200
:200 % PROFIT AND LOSS STATEMENT
:RUN(EXEC)
```

Output: PROFIT AND LOSS STATEMENT

### Example 4:

```
:50 A$ = "J. SMITH" : B$ = 923751
:100 PRINTUSING 200,A$,T
:200 % SALESMAN ##### TOTAL SALES $##,###.##
:RUN(EXEC)
```

Output: SALESMAN J. SMITH TOTAL SALES \$9,237.51

## 2.3 PROGRAMMING TECHNIQUES FOR FORMATTING AND CONVERSION OF DATA

The requirements for punching paper tape include formatting data in a specific format and character code before punching the data. It is, therefore, relevant to provide some examples of how formatting and conversion techniques can be done efficiently in the 2200:

### Formatting Numeric Values into a Specified Character Format

Data can be conveniently formatted in a specified format in ASCII code by using the CONVERT statement. For example:

```
:100 CONVERT X TO A$ (+###.####)
```

The floating point values of X, including the sign, three integer digits, a decimal point, and four fractional digits, are converted to ASCII characters and stored in the alphanumeric variable A\$. If required, the ASCII character can then be converted to some other character format by the routines described below.



### Floating Point to Binary Conversion

```
10 FOR I = 4 TO 1 STEP - 1
20 X = INT(X) /256
30 BIN (STR(A$, I, 1)) = (X - INT(X))*256
40 NEXT I
```

This program loop converts the integer floating point value of the variable X into a 4-byte binary value and stores it in A\$.

### Character Code Conversion

The \$TRAN statement provided in 2200B, 2200C Option 2, or the 2200S with Option 23 (\$TRAN) performs efficient, high-speed, character code translation of values of alphanumeric variables or arrays. The \$TRAN statement converts any 8-bit code to any other 8-bit code set via a lookup table supplied in the program. If the \$TRAN statement is not available in a 2200 system, the following BASIC program loop will accomplish code conversion:

```
:10 DIM A$ 64, B$(128) 1
.
.
.
:200 FOR I = 1 TO 64
:210 STR(A$, I, 1) = B$(VAL(STR(A$,I,1)))
:220 NEXT I
```

where:

A\$ contains 64 characters to be converted, and B\$ is a 128-character, code-conversion lookup table supplied in the program.

### 2.4 DIAGNOSTIC

A simple diagnostic can be executed to check the operation of the punch heads. To run the diagnostic, enter the following program:

```
:10 DIM K $1
:20 FOR I = 0 to 255
:30 BIN(K$) = I
:40 DATASAVE BT/41D, K$
:50 NEXT I
:RUN (EXECUTE)
```

Upon executing this program, the paper tape punch will punch holes in binary form sequentially from  $0_{10}$  to  $255_{10}$  ( $00000000_2$  to  $11111111_2$ ).

# APPENDIX A HEXADECIMAL AND BINARY CODES

## ASCII, Hex and Binary Codes with VAL Decimal Equivalents

The character set and control codes are those for the CRT; other devices such as printers have slightly different character sets (see the appropriate peripheral manuals). Codes between hex (80) and hex (FF) are Text Atoms and are not normally used as character data.

### LOW ORDER

	HEX →	0	1	2	3	4	5	6	7	8	9	A	B	C	D	E	F	
	↓	BINARY																
		0000	0001	0010	0011	0100	0101	0110	0111	1000	1001	1010	1011	1100	1101	1110	1111	
0	0000	NUL <small>0</small>	SOH (Cursor home) <small>1</small>		(Clear screen, Cursor home) <small>2</small>					(Alarm) <small>7</small>	(Cursor Back-Space) <small>8</small>	HT or Cursor right <small>9</small>	LF or Cursor down <small>10</small>	VT <small>11</small>	FF (Rev-Index) <small>12</small>	CR <small>13</small>	(Elongated Char.) <small>14</small>	SI (Shift Down) <small>15</small>
1	0001	DLE <small>16</small>	X-ON <small>17</small>		X-OFF <small>18</small>							Clear Tab <small>25</small>	Set Tab <small>26</small>					
2	0010	SP (Space) <small>32</small>	!	"	#	\$	%	&	(Quote) <small>39</small>	(	)	*	+	(Comma) <small>44</small>	(Dash) <small>45</small>	(Period) <small>46</small>	/	
3	0011	0 <small>48</small>	1 <small>49</small>	2 <small>50</small>	3 <small>51</small>	4 <small>52</small>	5 <small>53</small>	6 <small>54</small>	7 <small>55</small>	8 <small>56</small>	9 <small>57</small>	:	;	<	=	>	?	
4	0100	@ <small>64</small>	A <small>65</small>	B <small>66</small>	C <small>67</small>	D <small>68</small>	E <small>69</small>	F <small>70</small>	G <small>71</small>	H <small>72</small>	I <small>73</small>	J <small>74</small>	K <small>75</small>	L <small>76</small>	M <small>77</small>	N <small>78</small>	O <small>79</small>	
5	0101	P <small>80</small>	Q <small>81</small>	R <small>82</small>	S <small>83</small>	T <small>84</small>	U <small>85</small>	V <small>86</small>	W <small>87</small>	X <small>88</small>	Y <small>89</small>	Z <small>90</small>	[ <small>91</small>	\ <small>92</small>	] <small>93</small>	↑ <small>94</small>	← <small>95</small>	
6	0110	(Prime) <small>96</small>	a <small>97</small>	b <small>98</small>	c <small>99</small>	d <small>100</small>	e <small>101</small>	f <small>102</small>	g <small>103</small>	h <small>104</small>	i <small>105</small>	j <small>106</small>	k <small>107</small>	l <small>108</small>	m <small>109</small>	n <small>110</small>	o <small>111</small>	
7	0111	p <small>112</small>	q <small>113</small>	r <small>114</small>	s <small>115</small>	t <small>116</small>	u <small>117</small>	v <small>118</small>	w <small>119</small>	x <small>120</small>	y <small>121</small>	z <small>122</small>	{ <small>123</small>	 <small>124</small>	} <small>125</small>	~ <small>126</small>	■ <small>127</small>	
8	1000																	
9	1001																	
A	1010																	
B	1011																	
C	1100																	
D	1101																	
E	1110																	
F	1111																	
↑	HEX →	0	1	2	3	4	5	6	7	8	9	A	B	C	D	E	F	

0 = Zero      Numbers at lower right corner of  
 I = Letter i      each box are decimal (VAL) equivalents.

## APPENDIX B SPECIFICATIONS

Punching Speed . . . . .	50 Characters/sec. @ 60 Hz 44 Characters/sec. @ 50 Hz
Paper Tape Capacity. . . . .	8 1/2 in. (21.6 cm) diameter, 1000 ft (300 m)
Paper Tape Width . . . . .	11/16 in. (1.7 cm) minimum 1 in. (2.54 cm) maximum
Paper Tape Punch Size: . . . . .	Height 9 3/4 in. (24.76 cm) Depth 15 5/8 in. (39.62 cm) Width 13 7/16 in. (34.16 cm)
Weight . . . . .	23.5 lb (10.6 kg)
Power Requirements . . . . .	115 or 220 VAC + 10% 50 or 60 Hz $\pm$ 1 Hz
Cables . . . . .	12 ft (3.7 m) cable with connector for CPU controller board. 8 ft (2.4 m) to power source.
Operating Environment. . . . .	50 <sup>o</sup> F to 90 <sup>o</sup> F (10 <sup>o</sup> C to 32 <sup>o</sup> C) 20% to 80% relative humidity, non- condensing, 35% to 65% recommended.

## PREVENTIVE MAINTENANCE INFORMATION

### MAINTENANCE

It is recommended that your equipment be serviced quarterly. A Maintenance Agreement is available to assure this servicing automatically. If no Maintenance Agreement is acquired, any servicing must be arranged by the customer. A Maintenance Agreement protects your investment and offers the following benefits:

**Preventive Maintenance:** Your equipment is inspected quarterly for worn parts, lubricated, cleaned and updated with engineering changes, if any. Preventive maintenance minimizes "downtime" by anticipating repairs before they are necessary.

**Fixed Annual Cost:** When you buy a maintenance agreement, you issue only one purchase order for service for an entire year and receive one annual billing; more frequent billing can be obtained, if desired.

Further information regarding Maintenance Agreements can be acquired from your local Sales Service Office.

**NOTE:**

Wang Laboratories, Inc. does not guarantee or honor maintenance agreements for any equipment modified by the user. Damage to equipment incurred as a result of such modification becomes the financial responsibility of the user.

# INDEX

ASCII Code . . . . .	6, 26
Chad . . . . .	3
Chad Diverter . . . . .	3
Character Code Conversion. . . . .	25
Controller Board . . . . .	1, 2
Cover. . . . .	2
CPU. . . . .	2
DATASAVE . . . . .	11
DATASAVE BT. . . . .	13
Device Address . . . . .	2, 15
Diagnostic Program . . . . .	25
Floating Print Conversion. . . . .	24
HEX Codes. . . . .	6, 26
HEX PRINT. . . . .	16
High Order Bits. . . . .	6, 7
Interface Cable. . . . .	2
Installation . . . . .	2
Loading Tape . . . . .	6, 7
Low Order Bits . . . . .	6, 7
PRINT Statement. . . . .	16
PRINTUSING Statement . . . . .	18
Punch Cover. . . . .	4
Punch Solenoids. . . . .	1
Punch Speed. . . . .	2, 27
Recommended Systems . . . . .	9
SAVE . . . . .	14, 15
SELECT Statement . . . . .	15
Selecting the Model 9005 . . . . .	15
Specifications . . . . .	27
Suppressing Carriage Return. . . . .	18, 19
System Turn-on . . . . .	7
Tape Drawer. . . . .	4
Tape Guide . . . . .	4
Tape Movement. . . . .	4
Tape Specifications. . . . .	5
Tape Tear Plate. . . . .	3
Tape Width . . . . .	5
9005 Turn-on . . . . .	7
Unpacking. . . . .	2

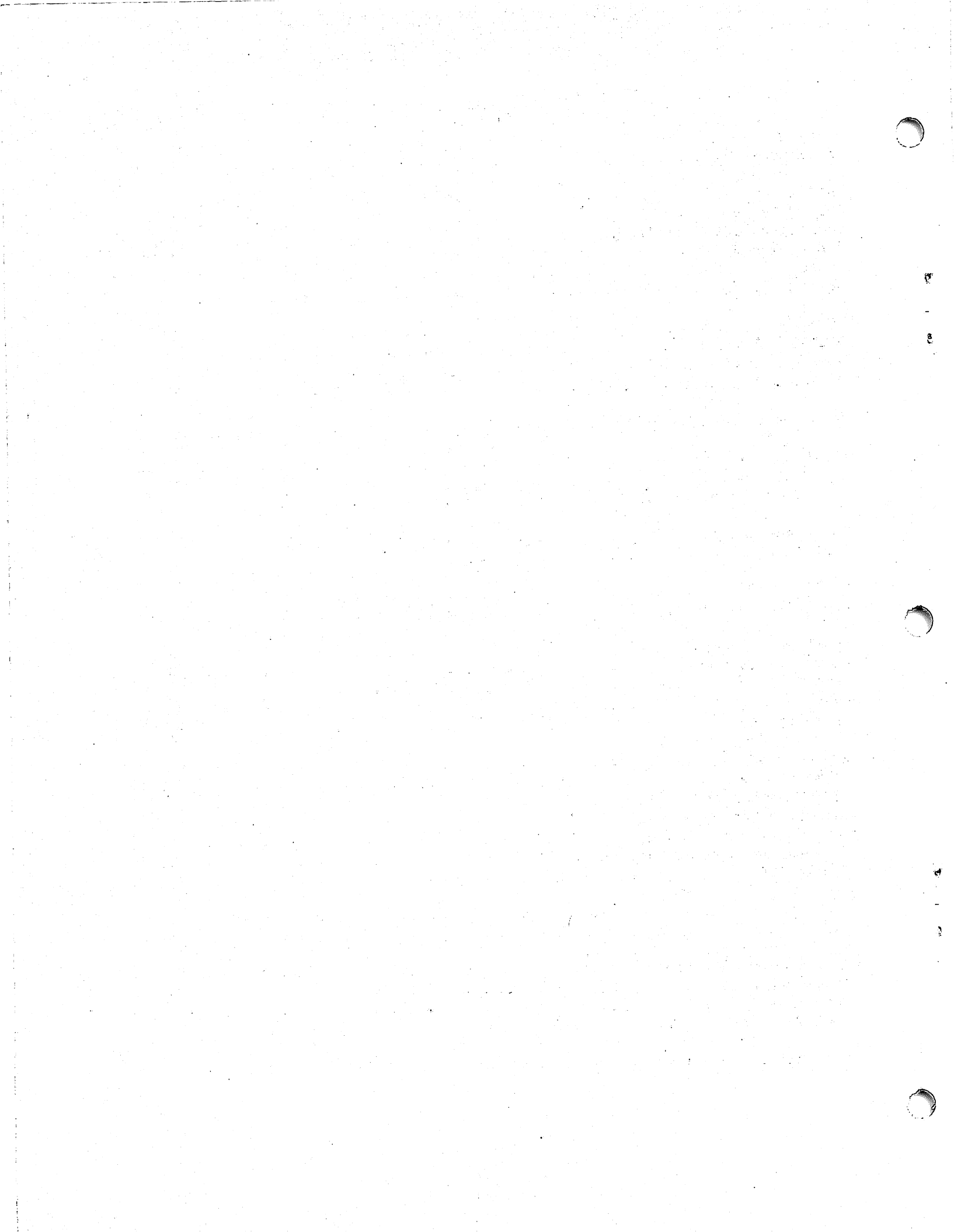

To help us to provide you with the best manuals possible, please make your comments and suggestions concerning this publication on the form below. Then detach, fold, tape closed and mail to us. All comments and suggestions become the property of Wang Laboratories, Inc. For a reply, be sure to include your name and address. Your cooperation is appreciated.

700-4618

TITLE OF MANUAL: MODEL 9005 PAPER TAPE PUNCH USER MANUAL

COMMENTS:

Fold

Fold

(Please tape. Postal regulations prohibit the use of staples.)

**WANG**

Fold

**FIRST CLASS**  
**PERMIT NO. 16**  
Tewksbury, Mass.

**BUSINESS REPLY MAIL**  
NO POSTAGE STAMP NECESSARY IF MAILED IN THE UNITED STATES

- POSTAGE WILL BE PAID BY -

**WANG LABORATORIES, INC.**  
**ONE INDUSTRIAL AVENUE**  
**LOWELL, MASSACHUSETTS 01851**

\_\_\_\_\_  
\_\_\_\_\_  
\_\_\_\_\_  
\_\_\_\_\_  
\_\_\_\_\_  
\_\_\_\_\_  
\_\_\_\_\_

Attention: Technical Writing Department

Fold

Cut along dotted line.



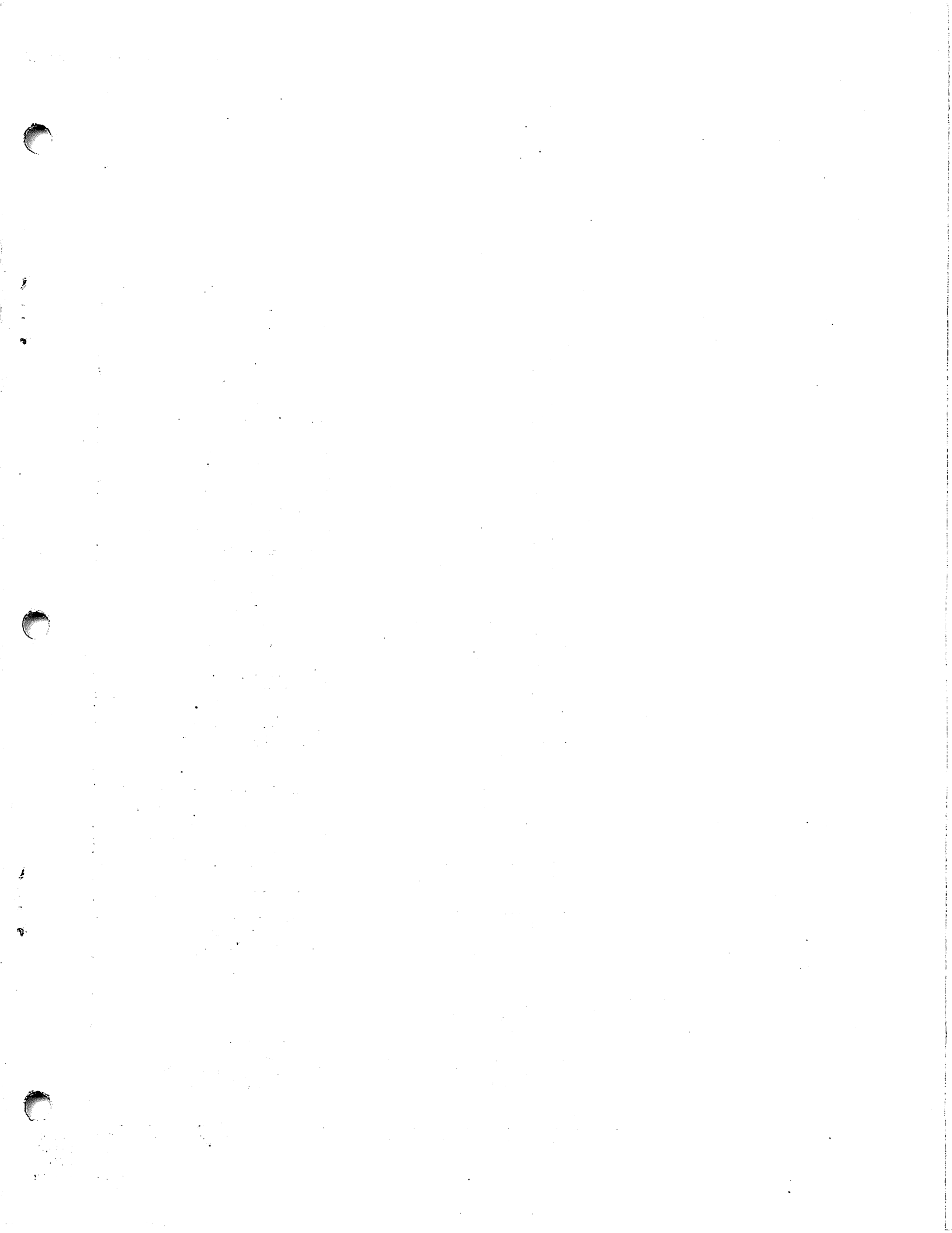

**WANG LABORATORIES  
(CANADA) LTD.**

240 Duncan Mill Road  
Suite 506  
Don Mills, Ontario M3B 1Z4  
Telex: 069-66546

**WANG EUROPE S.A./N.V.  
(European Headquarters)**

250, Avenue Louise  
1050 Brussels, Belgium  
TELEPHONE 02/640.37.80  
Telex: 12430-12398

**WANG EUROPE S.A./N.V.  
(Belgian Sales)**

350, Avenue Louise  
1050 Brussels, Belgium  
TELEPHONE 02/648.9.1.00  
Telex: 62691

**WANG DO BRASIL  
COMPUTADORES LTDA.**

Praca Olavo Bilac No. 28  
SL1801/1803  
Rio de Janeiro, Centro, RJ, Brasil  
TELEPHONE 232-7503, 232-7026

**WANG COMPUTERS  
(SO. AFRICA) PTY. LTD.**

Corner of Allen Rd. & Garden St.  
Bordeaux, Transvaal  
Republic of South Africa  
TELEPHONE (011) 48-6123  
Telex: 960--83297

**WANG INTERNATIONAL  
TRADE, INC.**

One Industrial Avenue  
Lowell, Massachusetts 01851  
TELEPHONE (617) 851-4111  
Telex: 94-7421

**WANG SKANDINAVISKA AB**

Pyramidvaegen 9A  
S-171 36 Solna, Sweden  
TELEPHONE 08/27 27 95  
Telex: 11498

**WANG COMPUTER LTD.**

Shindaiso Building No. 5  
2-10-7 Dogenzaka Shibuya-Ku  
Tokyo, Japan  
TELEPHONE (03) 464-0644  
Telex: 2424909 WCL TKO J

**WANG NEDERLAND B.V.**

Produktieweg 1  
IJsselstein, Netherlands  
TELEPHONE (03408) 41.84  
Telex: 47579

**WANG PACIFIC LTD.**

9th Floor, Lap Heng House  
47-50, Gloucester Road  
Hong Kong  
TELEPHONE 5-274641  
Telex: 74879 Wang HX

**WANG INDUSTRIAL CO., LTD.**

7, Tun Hwa South Road  
Sun Start Tun Hwa Bldg.  
Taipei, Taiwan, China  
TELEPHONE 7522068, 7814181-3  
Telex: 21713

**WANG GESELLSCHAFT MBH**

Murlingengasse 7  
A-1120 Vienna, Austria  
TELEPHONE 85.85.33'  
Telex: 74640 Wang a

**WANG GESELLSCHAFT MBH**

Wiedner Hauptstrasse 68  
A-1040 Vienna, Austria  
TELEPHONE 57.94.20  
Telex: 76424 Wang a

**WANG S.A./A.G.**

Markusstrasse 20  
Postfach 423  
CH 8042 Zurich 6, Switzerland  
TELEPHONE 41-1-60 50 20  
Telex: 59151

**WANG COMPUTER PTY. LTD.**

10-14 Paul Street  
Milsons Point, N.S.W. 2061  
TELEPHONE 439-3511  
Telex: 24569

**WANG ELECTRONICS LTD.**

Argyle House, 3rd Floor  
Joel Street  
Northwood Hills  
Middlesex, HA6 INS, England  
TELEPHONE (09274) 28211  
Telex: 923498

**WANG FRANCE S.A.R.L.**

Tour Gallieni, 1  
78/80 Ave. Gallieni  
93170 Bagnole, France  
TELEPHONE 33.1.3602211  
Telex: 680958F

**WANG LABORATORIES GmbH**

Moselstrasse 4  
6000 Frankfurt AM Main  
Postfach 16826  
West Germany  
TELEPHONE (0611) 252061  
Telex: 04-16246

**WANG DE PANAMA (CPEC) S.A.**

Apartado 6425  
Calle 45E, No. 9N. Bella Vista  
Panama 5, Panama  
TELEPHONE 69-0855, 69-0857  
Telex: 3282243

**WANG COMPUTER LTD.**

302 Great North Road  
Grey Lynn, Auckland  
New Zealand  
TELEPHONE Auckland 762-219  
Telex: WANG LTD NZ 21538

**WANG COMPUTER PTE., LTD.**

Suite 1801-1808, 18th Floor  
Tunas Building, 114 Anson Road  
Singapore 2, Republic of Singapore  
TELEPHONE 2218044, 45, 46  
Telex: RS 24160 WANGSIN

**WANG COMPUTER SERVICES**

One Industrial Avenue  
Lowell, Massachusetts 01851  
TELEPHONE (617) 851-4111  
TWX 710-343-6769  
Telex: 94-7421

**DATA CENTER DIVISION**

20 South Avenue  
Burlington, Massachusetts 01803  
TELEPHONE (617) 272-8550

**WANG**

LABORATORIES, INC.

ONE INDUSTRIAL AVENUE, LOWELL, MASSACHUSETTS 01851, TEL. (617) 851-4111, TWX 710 343-6769, TELEX 94-7421

Printed in U.S.A.  
700-4618  
3-78-3,5C

Price: see current list