

MODEL 9064
DATA SPEED* 40 EMULATOR MANUAL

"This document and the information it contains are the confidential property of, and are proprietary to, Wang Laboratories, Inc. This document and the information it contains may not be made public without the written consent of Wang Laboratories, Inc. If for any reason this document is permitted by Wang to leave the physical custody of the company, it is returnable upon the demand of Wang Laboratories, Inc."

TABLE OF CONTENTS

CHAPTER 1 INTRODUCTION

1.1	PRODUCT OVERVIEW	1
1.1.2	2236DE TERMINAL MODIFICATIONS	1
1.1.3	OPTIONAL PRINTER	1
1.1.4	SOFTWARE	1
1.1.5	DIAGNOSTICS	2
1.1.6	PRODUCT PART NO.	2
1.1.7	BILL OF MATERIALS	2
1.1.8	RECOMMENDED SPARES LISTING	2
1.2	DESCRIPTION	3

CHAPTER 2 OPERATION

2.1	INTRODUCTION	4
2.2	SYSTEM CONFIGURATION	4
2.3	WORKSTATION OPERATION	5
2.4	CONTROLS AND INDICATORS	5
2.4.1	CONTROL KEYS	5
2.4.2	SCREEN CONTROL KEYS	9
2.4.3	PRINTER CONTROL KEYS	11
2.4.4	TRANSMISSION CONTROL KEYS	12

CHAPTER 3 SWITCH SETTINGS

3.1	INTRODUCTION	13
3.2	TERMINAL AND PRINTER ADDRESS SWITCH SETTINGS	13
3.2.1	TERMINAL SWITCH SETTINGS	13
3.2.2	PRINTER ADDRESS SETTING	14
3.3	BAUD RATE SELECTION	14
3.4	2228B SWITCH SETTING	15

CHAPTER 4 REMOVAL/REPLACEMENT/INSTALLATION

4.1	INTRODUCTION	16
4.2	WORKSTATION COVER REMOVAL	16
4.3	T294 PCB REPLACEMENT	16

CHAPTER 5
TROUBLESHOOTING

5.1	INTRODUCTION	18
5.2	RECOMMENDED SPARES LIST	18
5.3	TEST PROGRAM	18
5.4	9064 ACCESS	22
5.5	2200 \$GIO SEQUENCES	23
5.6	ACCESSING FUNCTIONS REMOTELY	24
5.7	210-7592 MODIFICATIONS	25

CHAPTER 1

INTRODUCTION

This 9064 Service Manual provides information pertaining to the servicing of the 9064 Data Speed 40* Emulator Terminal (P/N 190-0304) at a field level of maintenance. This manual will deal primarily with the 2236DE Terminal modifications required to emulate a Data Speed*40 Terminal and how it is interfaced to a 2228B TC Controller.

1.1 PRODUCT OVERVIEW

The following table provides a summary of the 9064 specifications and operational characteristics.

1.1.2 2236DE TERMINAL MODIFICATIONS

- a. On the 210-7592 PCB, PROMS at location L-17 and L-18 are replaced with PROMS containing Data Speed 40 Emulator microcode.
- b. A new switch address PCB (210-T294) is mounted at location L-16 on the 210-7592 PCB.
- c. New CRT character PROMS are loaded at location L-55 and L-56.
- d. The printer ready and acknowledge signals on the 210-7592 PCB are tied together to form a single status bit (see section 5.7).
- e. Keyboard finishing plate was modified to accomodate extra keys.
- f. Sixteen (16) new key caps and fourteen (14) new inserts are being used. See figure 2.

1.1.3 OPTIONAL PRINTER

Standard 2233-120 characters/sec. printer is used.

* Register Trademark of AT & T Co.

1.1.4 SOFTWARE

Application Software is developed by a vendor for the customer.

1.1.5 DIAGNOSTICS

2228B diagnostic to check out the board.

Test diskette supplied by Special Products to check out terminal.

1.1.6 PRODUCT PART NO.

Model Number: 9064
Part Number: 190-0304

1.1.7 BILL OF MATERIALS

Same as 187-3236 DE terminal except keyboard plate, also the 210-7592 PCB has been modified (refer to paragraph 5.7) and has been assigned a new part no. 210-7592-1U.

210-T294 Address PCB

Data Speed* 40 PROMS

Part # / Location #: 378-4307 / L17
378-4304 / L18
377-0323 / L55
377-0323 / L56

1.1.8 RECOMMENDED SPARES LISTING

210-7592-1U (modified 7592 PCB).

210-T294 PCB

Standard 2236DE PROMS to check out terminal as a 2236DE
Part # / Location #: 378-2446-R3 / L16
378-4094-R4 / L17
378-4095-R4 / L18

1.2 DESCRIPTION

The 9064 Special Product is a Data Speed* 40 Emulator which consists of a 2236DE terminal enhanced with a PCB and firmware to support the Data Speed* 40 protocol. The keyboard is adapted to provide special inserts required to use the protocol. The 9064 is interfaced to a 2228B TC Controller at a 1200 baud rate. The hardware consists of a modified 7592-1U PCB and a switch address PCB, developed for polling addresses for printers and 2236DE terminals in a multidrop fashion.

CHAPTER 2 OPERATION

2.1 INTRODUCTION

The 9064 Terminal is a special product designed to modify the current 2236DE Terminal to emulate a DSP 40 Terminal. This chapter will include explanations of system configuration and electronic assemblies in sufficient detail to aid the Service Representative in understanding the operation of 9064 Terminal.

2.2 SYSTEM CONFIGURATION (Figure 1)

Each station in the system can consist of several 9064 workstations clustered around 1 or more 2228B Controllers. Clustering is available in a range of up to 16 (9064) workstations and 16 (2233) printers per (2228B) controller board.

Printers are connected directly to workstations via a printer port located at the rear of the workstation.

The smallest possible configuration consists of 1 (9064) workstation and an optional (2233) printer coupled to a 2228B Controller.

The 2228B Controller contains the logic and data storage electronics for the devices to be coupled to, and the workstation contains the line protocol logic required for the station to operate in the system, including the electronics required for polling and selection address recognition and replies.

2.3 WORKSTATION OPERATION

Terminal operation is under the control of the CPU. The operator is primarily concerned only with obeying instructions from the CPU which are displayed on the CRT, and with entering the data called for. Printer operation is minimized to loading paper and removing selected messages.

Operation of the Terminal (keyboard display) device is done by means of the keyboard (see figure 2).

2.4 CONTROLS AND INDICATORS

2.4.1 CONTROL KEYS (see figure 2)

SEND -- Puts the terminal in bid (send) mode, and sends text, when polled, from the cursor location to end of text.

RCV (Receive) -- Puts the terminal in receive mode, and permits it to receive (when addressed) from the cursor location to the end of display memory.

LOCL (local) -- Puts terminal in display mode, to permit data to be entered and displayed.

FORM SEND -- Overrides send options associated with the SEND key, to permit all data (including protected data) to be sent as displayed.

PRINT ON-LINE -- Permits terminal printer to receive and print when addressed unless SEND key depressed, or regardless of SEND key, depending on option elected. Also causes printer to print sent data.

PRINT LOCL (print local) -- Causes terminal printer to print all data in display memory as displayed, from cursor location to end of display memory.

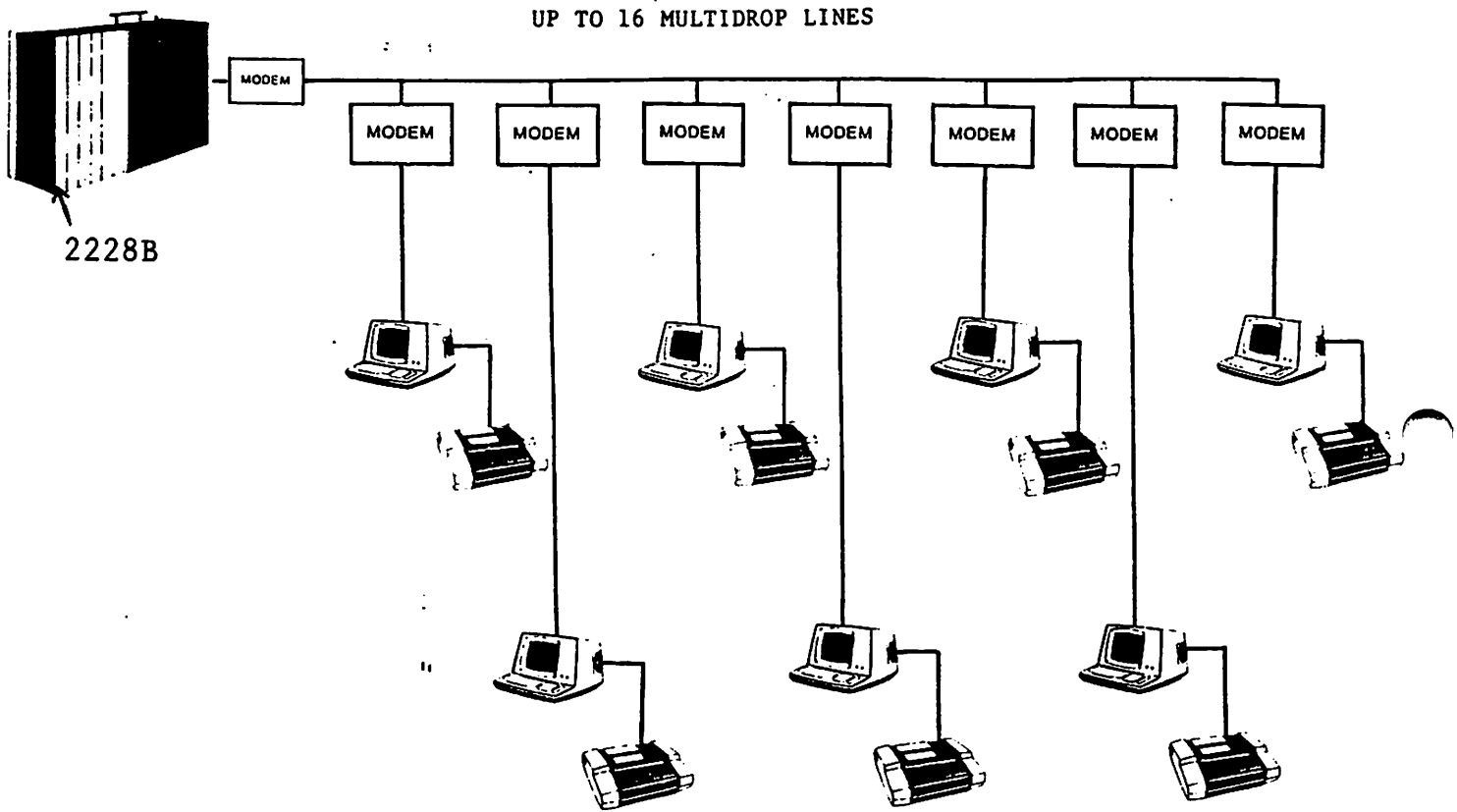

FIGURE 1 -- SYSTEM CONFIGURATION

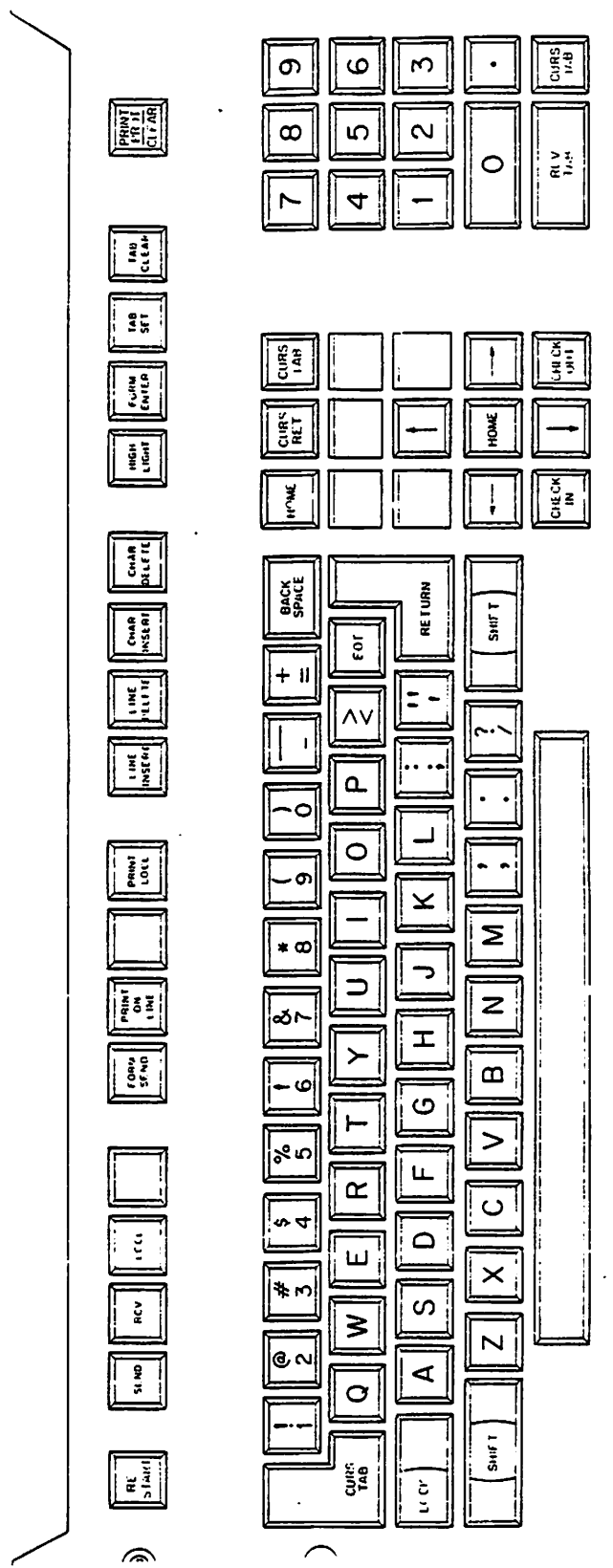

FIGURE 2 -- KEYBOARD LAYOUT

HIGHLIGHT -- Causes characters that follow to be highlighted.

FORM ENTER -- Causes characters that follow to be protected. Also puts Terminal into protected data mode whereas on-line and off-line controls affect protected as well as protected data.

TAB SET -- Sets tab stops at cursor column location, on that line and all lines below to the bottom of the screen.

TAB CLEAR -- Clears all tab stops at the cursor column location and all lines below to the bottom of the screen.

CLEAR -- Clears all unprotected data on the screen.

SHIFT CLEAR -- Clears all data from the screen (protected and unprotected).

Cursor Controls

HOME -- Moves the cursor to the start of the first line.

CURSR RTRN - Moves cursor to start of line.

UP/DOWN/LEFT/RIGHT ARROW -- Moves cursor in the direction indicated by arrows.

CURSR TAB -- Moves the cursor to the first tab stop to the right or to the start of the next line, or to the first unprotected character following protected data, whichever comes first.

Editing Controls

LINE DELETE -- Clears unprotected data from the line the cursor is on and moves all unprotected data displayed below, up one line. If a protected field is found, no further data is moved up.

CHAR INSRT -- Moves unprotected data one character to the right and creates a space at the cursor position. Does not occur if there are no character spaces at the end of the line, or if there are no character spaces before the first protected character or if the first tab stop displayed is on the right.

CHAR DELETE -- Clears unprotected character at the cursor location and moves all unprotected data displayed on the right one character position to the left.

LINE INSERT -- Moves unprotected data down one line to create a line of spaces on the line the cursor is on. Does not occur if there are no lines of space at the end of the display memory, or if there are no lines of space above the first line below having protected data on it.

2.4.2 SCREEN CONTROL KEYS (Data Input)

All keys (except * below) move the cursor position. At column 1, cursor wraps around to column 80 of same line; at column 80, cursor wraps around to column 1 of the same line. At row 1, cursor wraps around to row 24 of the same column; at row 24, cursor wraps to row 1, same column. For all functions, the integrity of all protected fields and Tab data is preserved unless in the Form Enter Mode.

HIGHLIGHT* -- First depression turns on high intensity. Second depression turns off high intensity.

FORM ENTER* -- Sets Form Enter mode and underscores all input characters until Form Enter is depressed again. Allows insert and delete in protected fields.

TAB SET* -- Tabs are set in the entire column of the current cursor column.

TAB CLEAR* -- Clears Tabs in the entire column of the current cursor column.

CLEAR -- Clears all unprotected data from cursor on. Cursor is replace to home position when clear finished.

SHIFT CLEAR -- Clears the entire screen including protected fields. Cursor is replaced to original position when clear finished.

HOME -- Cursor is placed at upper left corner. Highlight and Form Enter are turned off.

CURSR RETRN -- Returns cursor to first column of the same line.

<u>Up</u>	Decrements ROW
<u>Down</u>	Increments ROW
<u>Left</u>	Decrements COL
<u>Right</u>	Increments COL

CURSR TAB -- Move right until Tab is found or until first character after a Protected Field is found. At end of row, continue onto next row. At bottom right, move to home.

REV TAB -- Move left until Tab is found or until first character after a Protected Field is found. At beginning of row, move to last char of previous row. Stop at HOME position.

LINE DELETE -- Erase contents of current line, and replace with contents of next line. Copy all lines until the end of screen or until a line with a protected field is encountered.

CHAR INSRT* -- Move all characters right until the end of line or until a protected field is encountered. Prohibit insert into protected field unless in Form Enter mode. Replace cursor location with a space.

CHAR DELETE* -- Move remaining line to right of cursor left one character. Unless in Form Enter mode, do not delete protected characters.

LINE INSERT* -- Insert a blank line with current Tab settings at the cursor row. Move the current line down one, until the end of screen or until a line with protected data is found. Line insert while in Form Enter mode allows movement of protected data.

2.4.3 PRINTER CONTROL KEYS

PRINT ON-LINE - Data input allowed. Received data to printer or CRT is accepted and forwarded.

PRINT LOCAL - Sends data from current cursor position to end of screen to printer.

2.4.4 TRANSMISSION CONTROL KEYS

SEND -- Data input inhibited. Protected fields not transmitted. Reset by HOST to receive.

REC -- Data input inhibited. Data received to CRT. Reset by HOST to local.

LOCAL -- Data input allowed. Data reception sent to printer.

FORM SEND -- All data on CRT sent.

CHAPTER 3 SWITCH SETTINGS

3.1 INTRODUCTION

Included in this chapter are all the switch settings necessary for installing a 9064 terminal.

3.2 TERMINAL AND PRINTER ADDRESS SWITCH SETTINGS

The printer and terminal address selection switches for the 9064 are located on the 210-T294 PCB. The following switch settings must be checked or performed when installing or removing this PCB.

The following are examples of typical terminal and printer address switch settings. Actual address settings will depend upon the application. The terminal and printer addresses shown in the example are for one 9064 station, if multiple stations are used each terminal and printer would have a different address setting.

3.2.1 TERMINAL SWITCH SETTINGS (example)

Poll Address Alpha/Numeric = A1
 A1 is converted to ASCII A = HEX 41, 1 = HEX 31
 Binary equivalent 41 = 0100 0001, 31 = 0011 0001

```

SW 1 (1st character in poll)
:1 2 3 4 5 6 7 8:
: X X X X X X X: ON
: X X X X X X X: OFF
: 0 1 0 0 0 0 0 1:
MSB                               LSB
  
```

```

SW 2 (2nd character in poll)
:1 2 3 4 5 6 7 8:
: X X X X X X X: ON
: X X X X X X X: OFF
: 0 0 1 1 0 0 0 1:
MSB                               LSB
  
```

3.2.2 PRINTER ADDRESS SETTING (example)

Poll Address Alpha/Numeric = B2
B2 is converted to ASCII B = HEX 42, 2 = HEX 32
Binary equivalent 42 = 0100 0010, 32 = 0011 0010

SW 3 (1st character in poll)

1	2	3	4	5	6	7	8	
	X					X		ON
X		X	X	X	X		X	OFF
0	1	0	0	0	0	1	0	
MSB				LSB				

SW 4 (2nd character in poll)

1	2	3	4	5	6	7	8	
		X	X			X		ON
X	X			X	X		X	OFF
0	0	1	1	0	0	1	0	
MSB				LSB				

3.3 BAUD RATE SELECTION

The baud rate selection switch for the 9064 is located on Switch 1 of the 210-7592-1U PCB. Slide Switch 1 must be OFF and Slide Switch 2 must be ON; these two switches determine the number of data bits (7 data bits) and type of parity used (even). The baud rate is set to 1200 baud, therefore the switch settings are as follows: Slide Switches 3 and 5 ON and Slide Switch 4 OFF. The maximum board rate is 1200 baud. NOTE: The 9064 is shipped with the 7592-1U set for 1200 baud. Switch is only set when board is replaced.

SW1

5	!	X	!		!
4	!		!	X	!
3	!	X	!		!
2	!	X	!		!
1	!		!	X	!
		ON		OFF	

3.4 2228B SWITCH SETTING

Switch 1 located on the motherboard of the 2228B TC Controller must be set to the proper address. The following information should aid the Service Representative in correctly setting this switch. In the following example the address is set to 01C, actual address setting will depend on the specific application.

01C

<u>1</u>	<u>2</u>	<u>3</u>	<u>4</u>	!	<u>5</u>	<u>6</u>	<u>7</u>	<u>8</u>
!		X	X	!	X			!ON
!	X	X		!		X	X	X!OFF
!	LSB		MSB	!	LSB		MSB	!
!		C		!		1		!

CHAPTER 4

REMOVAL/REPLACEMENT/INSTALLATION

4.1 INTRODUCTION

Equipment to be replaced or installed may be in accordance with the procedures and illustrations contained in this chapter. Before removing the following assemblies, ensure that the power switch is OFF and the AC power cord is unplugged.

4.2 WORKSTATION COVER REMOVAL

- a. Remove the three Phillips screws located under the plastic strip on the keyboard and remove the keyboard plate.
- b. Remove the Phillips screws on the left and right side of the workstation cover.
- c. Lift the cover up and away from the workstation; take care not to hit or nick the CRT, or strain the Brightness/Contrast wires.
- d. Remove the Brightness and Contrast control wires from the clamp on the side of the cover. Lay the cover on its side next to the workstation. Do not unplug the Brightness and Contrast Molex connector from the cross-brace at the top of the CRT.

4.3 T294 PCB REPLACEMENT

The T294 PCB has been installed into the 9064 terminal, the following procedure in for replacement of that PCB.

A. T294 PCB REMOVAL

1. Remove the upper right Phillips-head screw holding the T294 and the 210-7592-1U PCB to the CRT chassis support rods.

2. The T294 PCB should can be unplugged from the the 7592-1U PCB.

B. T294 PCB INSTALLATION

1. Align the J1 connector on the T294 PCB with the L16 PROM connector on the 7592-1U PCB. Connect the T294 PCB to the 7492-1U PCB.
2. Secure the T294 and 7592-1U PCBs to the chassis support rod using a 6-32 X 3/4 (P/N 650-3240) screw with a 1/2" standoff (P/N 462-0204). NOTE: The standoff is positioned between T294 and the 7592-1U PCBs (see figure 3).
3. Install workstation cover.

CHAPTER 5 TROUBLESHOOTING

5.1 INTRODUCTION

Troubleshooting the 9064 Terminal consist of running a few simple tests and running an application test program. Replaceable items are listed in paragraph 5.2 (Recommended Spares List). To troubleshoot the 2236DE terminal refer to

5.2 RECOMMENDED SPARES LIST

210-7592-1U Modified (a seperate part number to be assigned).

210-T294 PCB

Standard 2236DE PROMS to check out terminal as a 2236DE

NOTE: Insert the 2236DE PROMS to run 2236DE diagnostics (refer to the Customer Engineering Service Newsletter No. 181).

<u>Part #</u>	<u>/ Location #</u>
378-2446-R3	/ L16
378-4094-R4	/ L17
378-4095-R4	/ L18

5.3 TEST PROGRAM

In this system, the CPU can receive a message from a station after polling it or it can send a message to a station after selecting it, however, both functions cannot be carried out simultaneously on the same communications channel. Nor can it deliver a message to more than one station on the same channel at the same time.

To run the following test, the 9064 Data Speed* 40 Emulation PROMs must be installed (refer to paragraph 1.1.7 for PROM part nos.). The following test program can be used to send or receive messages between a 9064 terminal and a CPU terminal.

! 2236DE !	!2200MVP!	! 2228B !	!NULL !	! 9064 !
!Terminal!	! CPU !	!CONTROLLER!	!MODEM!	!TERMINAL!

TEST SET-UP

To perform this test, the following Test Program must be loaded. Load the "TEST PROGRAM" diskette.

TEST PROGRAM

```

10 DIM A$(4)64,P$3,Z9$1,C1$(4)32,C$18,F$8,B$81,H$80,T$80,S$80,L$120,P1$2
20 SELECT #701C: $GIO#7,(4580,E$)
30 $GIO#7,(4408,E$)
40 PRINT HEX(03)
50 C$=ALL(00): STR(C$,1,6)-HEX(1920215E0001)
60 $GIO SET CCV #7,(4402 A000 440C,E$)C$
70 INPUT "POLLING ADDRESS =",P1$
80 P$=P1$&HEX(7F)
90 DEFFN' 31
100 PRINT HEX(03)
110 PRINT AT(5,10);"TO SEND MESSAGE TO DSP40          PRESS SF KEY 0"
120 PRINT AT(1,1);"POLLING ADDRESS = ";P1$
130 PRINT AT(6,10); "TO RECEIVE MESSAGE FROM DSP 40    PRESS SF KEY 16"
140 STOP
150 DEFFN' 00
160 H$=ALL(00)
170 INPUT "MESSAGE TO BE SENT =",H$
180 $GIO#7, (440A A000 440C,E$)P$
190 $GIO#7,(440A 4001 4002 A000 4003 4004 440C,E$)H$
200 FOR X= 1 TO 1000: NEXT X
210 $GIO#7, (440A A000 440C,E$)P$
220 $GIO#7,(4409 1020 02FF 1223 C620,E$)S$
230 IF STR(S$,1,1)=HEX(4E) THEN 250
240 IF STR(S$,1,1)=HEX(59)THEN 270: GOTO 280
250 PRINT HEX(03);"TERMINAL IN LOCAL";
260 GOTO 180
270 PRINT HEX(03), "MESSAGE SENT"
280 STOP"          PRESS SF KEY 31 TO CONTINUE"
290 GOTO 180
300 DEFFN'16
310 FOR Z= 1 TO 2
320 $GIO#7, (440A A000 440C,E$)P$
330 $GIO#7,(4409 1020 02FF 1223 C620,E$)L$
340 FOR X=1 to 10000: NEXT X

```

cont. on next pg.

```

350 NEXT Z
360 IF STR(L$,1,2)=HEX(4E15)THEN 380
370 IF STR(L$,1,1)=HEX(59)THEN 380:GOTO 400
380 PRINT HEX(03);AT(5,10);"TERMINAL WAS NOT IN SEND MODE"
390 STOP
400 PRINT HEX(03);L$
410 PRINT AT(5,1);"MESSAGE RECEIVED"
420 STOP "      PRESS SF 31 TO CONTINUE"

```

Once loaded the 2200 System terminal will ask:

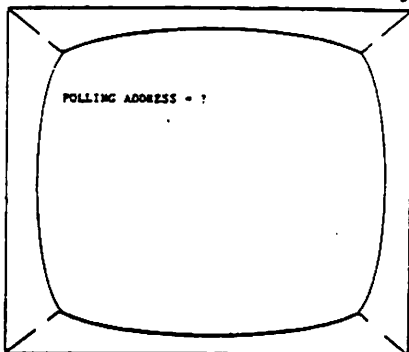

Enter address of 9064 terminal to be tested
depress RETURN

The 2200 System terminal will respond:

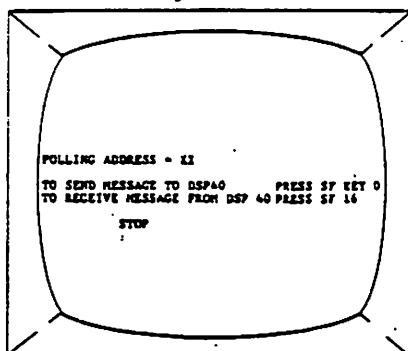

The 2200 System terminal will respond:

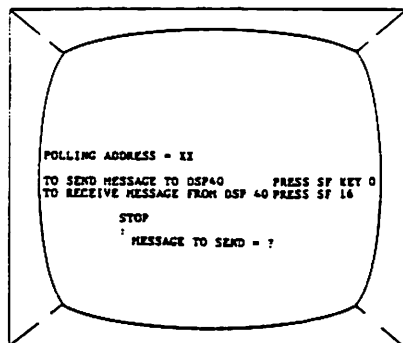

Enter message up to 80 characters

Depress RETURN

NOTE: If 9064 terminal is in local, "TERMINAL IN LOCAL" will appear on the 2200 System terminal. Once the 9064 is in the receive mode the 2200 System terminal will respond:

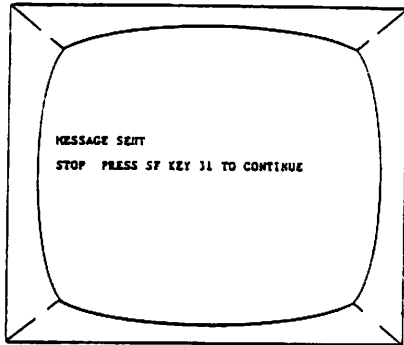

Message will appear on 9064 terminal

To receive a message on the 2200 System terminal from the 9064 terminal perform the following:

Depress SF 31

Enter message up to 80 characters on 9064 terminal

Depress 9064 "SEND" key

Depress "SF 16" Key on 2200 System terminal

The 2200 System terminal will respond:

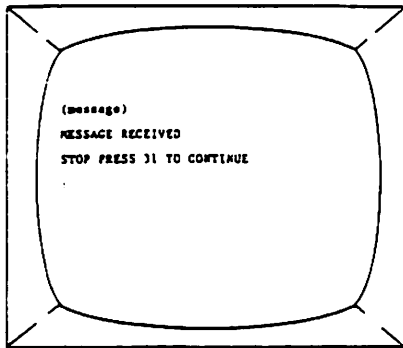

5.4 9064 ACCESS

- a. 2200 System program access can be achieved with the below or similar (depending on application) programming.

1. POLLING

Polling of the terminals is done by sending the sequence:

XY(del) where: X=first poll char
Y=second poll char
(del)=DEL code (x'7F')

For poll to device "A1" Ex: \$GIO/01C(440A 4041 4031 407F,E\$)
A 1

The terminal responds with any of the following three messages:

N(nak) where: N=hex(4E); (nak)=hex(15)
Signifies address not ready to receive, and no message to send. (Usually, terminal in LOCAL)

Y(ack) where: Y=hex(59); (ack)=hex (06)
Signifies address ready to receive, and no message to send. (Usually, terminal in RCV)

(soh stx data etx eot)

where: soh = hex (01); stx = hex (02)
etx = hex (03); eot = hex (04)

Signifies terminal was in SEND and current screen is sent as data. To Xmit to the 9064 a message after receiving this message from the terminal, the terminal must be repolled.

Broadcast polling is done by sending the sequence:

Sa(del) where: S=hex (53); a=hex(61); del=hex(7F)
All terminals respond by entering RCV mode with no acknowledgement to the sender.

Ex: \$GIO/01C(440A 4053 4061 440C,E\$)
 S a

2. COMMUNICATIONS

The following protocol is used for communication:

Asynchronous
1200 baud
Full Duplex
7 Data bits, even parity, 1 stop bit

5.5 2200 \$GIO SEQUENCES

With the 2228B set up with the following:

CCV : INIT(00)C\$: STR(C\$,1,6)=HEX(1920215E0C01)
\$GIO SET CCV #7,(4402 A000 440C,E\$)C\$

(Note: Assuming terminal address A1 = HEX (4131)
The following operations to the terminal are used:

POLL CHAR P\$=HEX(41317F)

POLL \$GIO/01C(440A A000 440C,E\$) P\$

DATA OUT \$GIO/01C(440A 4001 4002 A000 4003 4004 440C,E\$) A\$()
SOH STX DATA ETX EOT

(Note: Data already constructed into A\$())

DATA IN \$GIO/01C(4409 1020 02FF 1223 C620,E\$) A\$()
(MVP)

(NOTE: A DATA IN following a POLL will yield Nnak, Yack, or MSG)

5.6 ACCESSING FUNCTIONS REMOTELY

The functions of the terminal may be accessed by sending the following codes in the normal message format (SOH STX FUNC ... ETX EOT). These functions conform to their definition as they are used in LOCAL Mode.

<u>Function</u>	<u>ASCII Control</u>	<u>Hex</u>
1. Bell-rings terminal	BEL	07
2. Set Tab at cursor column	ESC 1	1B30
3. Clear Tab at cursor column	ESC 2	1B32
4. Highlight on	ESC 3	1B33
5. Highlight off	ESC 4	1B34
6. Protected Field On	ESC W	1B57
7. Protected Field Off	ESC X	1B58
8. TAB	ESC @	1B40
9. Cursor Up	ESC 7	1B37
10. Cursor Down	ESC B	1B42
11. Cursor Right	ESC C	1B43
12. Cursor to Start of Line	ESC G	1B47
13. Cursor Home	ESC H	1B48
14. Clear all unprotected data	ESC J	1B4A
15. Insert Line*	ESC L	1B4C
16. Delete Line*	ESC M	1B4D
17. Insert Char*	ESC (up arrow)	1B5
18. Delete Char*	ESC P	1B50
19. Clear	ESC R	1B52
20. Restart terminal processor	ESC (can)	1B18

* Note: These functions conform to the rules of the terminal in local:
i.e. data is moved until a protected field is located, etc.

For troubleshooting the 2236DE terminal refer to the Customer Engineering Service Newsletter No. 181 (III.D.1, reorder # 729-0476).

5.7 210-7592 MODIFICATIONS

The 210-7592 PCB has been modified to combine Printer Ready and Acknowledge into one status bit, this allows quicker Printer Ready information which is needed for the 1200 baud telecommunications. The following modifications are made to the 7592 PCB (refer to figure 4).

1. Cut etch to L28-8 from L37-1 (see figure 4).
2. Jumper J1 pin 11 to L42 pin 13.
3. Jumper L42 pin 12 to L40 pin 13.
4. Jumper L28 pin 8 to L40 pin 12.
5. Jumper L37 pin 1 to L40 pin 11.
6. Connect the 4.7k Pull-up Resistor to J1 pin 11.

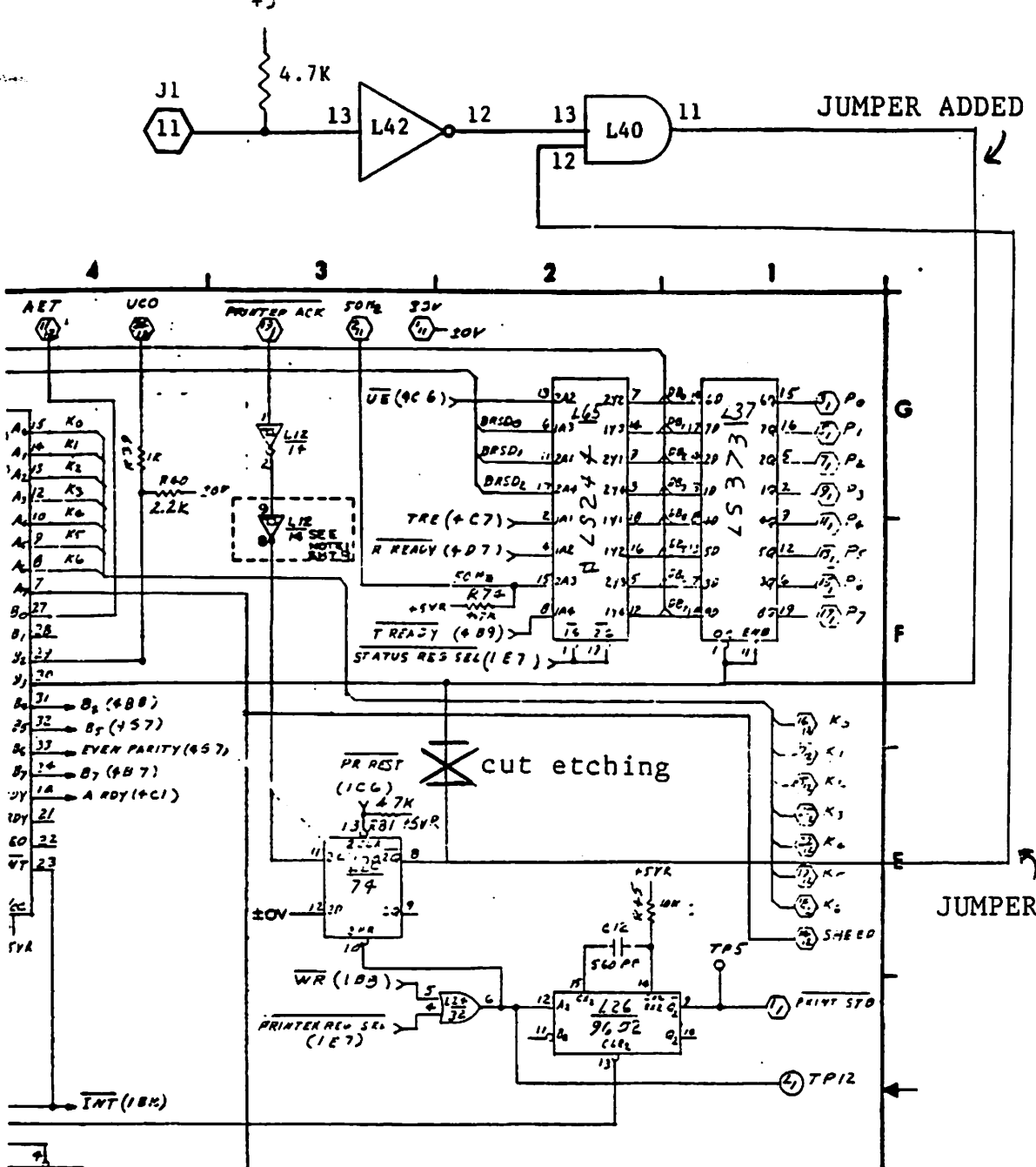
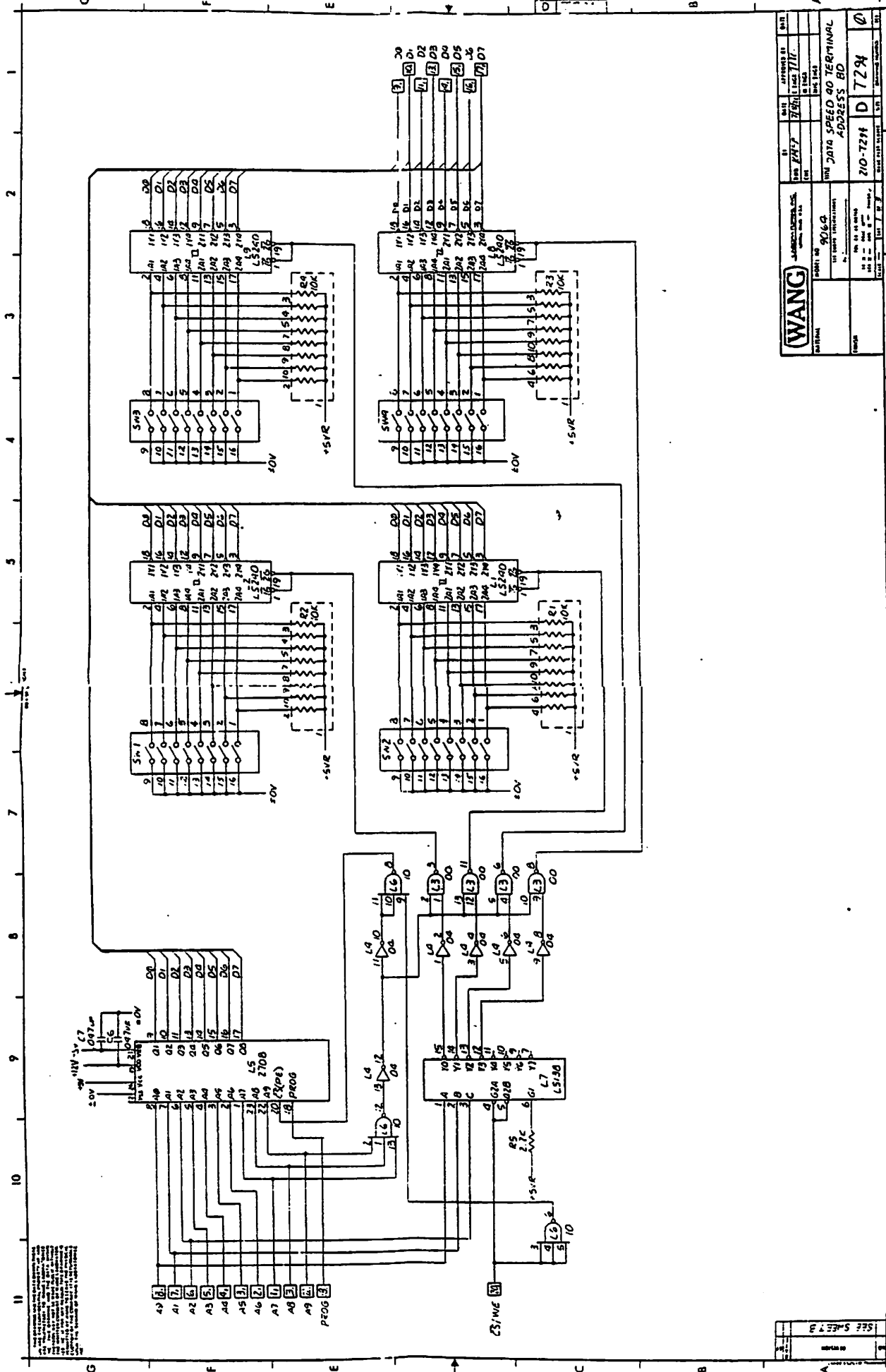

FIGURE 4 -- 2236DE MODIFICATION



1. THIS DRAWING IS THE PROPERTY OF WANG LABORATORIES, INC. AND IS NOT TO BE REPRODUCED OR TRANSMITTED IN ANY FORM OR BY ANY MEANS, ELECTRONIC OR MECHANICAL, INCLUDING PHOTOCOPYING, RECORDING, OR BY ANY INFORMATION STORAGE AND RETRIEVAL SYSTEM, WITHOUT THE WRITTEN PERMISSION OF WANG LABORATORIES, INC.

WANG		DATE: 7/11/77	BY: J. J. JONES
DRAWN BY: J. J. JONES		DATE: 7/11/77	BY: J. J. JONES
CHECKED BY: J. J. JONES		DATE: 7/11/77	BY: J. J. JONES
APPROVED BY: J. J. JONES		DATE: 7/11/77	BY: J. J. JONES
TITLE: DATA SPEED 40 TERMINAL		ADDRESS: D	7294
PART NO: 9066		REV: 1	REV: 1
REV: 1		REV: 1	REV: 1

SEE SHEET 3

Computers

TO	DISTRIBUTION	PUBLICATION #	1D
FROM	INDUSTRY MARKETING	DATE	MARCH 16, 1981
SUBJECT	2236DE/2236DW INTERFACE TO CASH DRAWER	REORDER FROM:	
THIS RELEASE SUPERSEDES:		DESTROY SUPERSEDED INFORMATION	<input type="checkbox"/> YES <input type="checkbox"/> NO

The information contained in this release does not constitute an endorsement of the cash drawer. This is intended to furnish the capability to interface the WANG 2236DE and 2236DW Multi-Function Terminal to the cash drawer manufactured by APG, Inc.

The function of the 2236DE/DW Workstation as cashier or teller unit will aid in securing 2200 sales in a number of industries. The following are representative of industry areas where combination of 2236DE/DW and cash drawer are in demand.

Retail	Distributors
Credit Unions	Small Banks
Restaurants	Utilities
Local Government	College Food Service

With the cooperation of the Special Product Group within Customer Engineering, the interface has been developed for mounting in the 2236DE/DW Terminal prior to shipment of 2236DE/DW to customer.

Model 9057
 Part Number 190-0300.
 Purchase \$750.00
 Monthly Maintenance \$8.00

Operation

The cash drawer is under program control of the 2200. A hex (02) sent to the 2236DE/DW printer output (address 204) will open the drawer. Examples of two program sequences to open the drawer are given below:

Example No. 1 - Using Function Key 0 to open drawer

```
05 DEFFN'O
10 Select Print 204
20 Print Hex (02)
30 Select Print 005 (or last device selected)
```

Example No. 2

```
10 $G10/204 (4002)
```

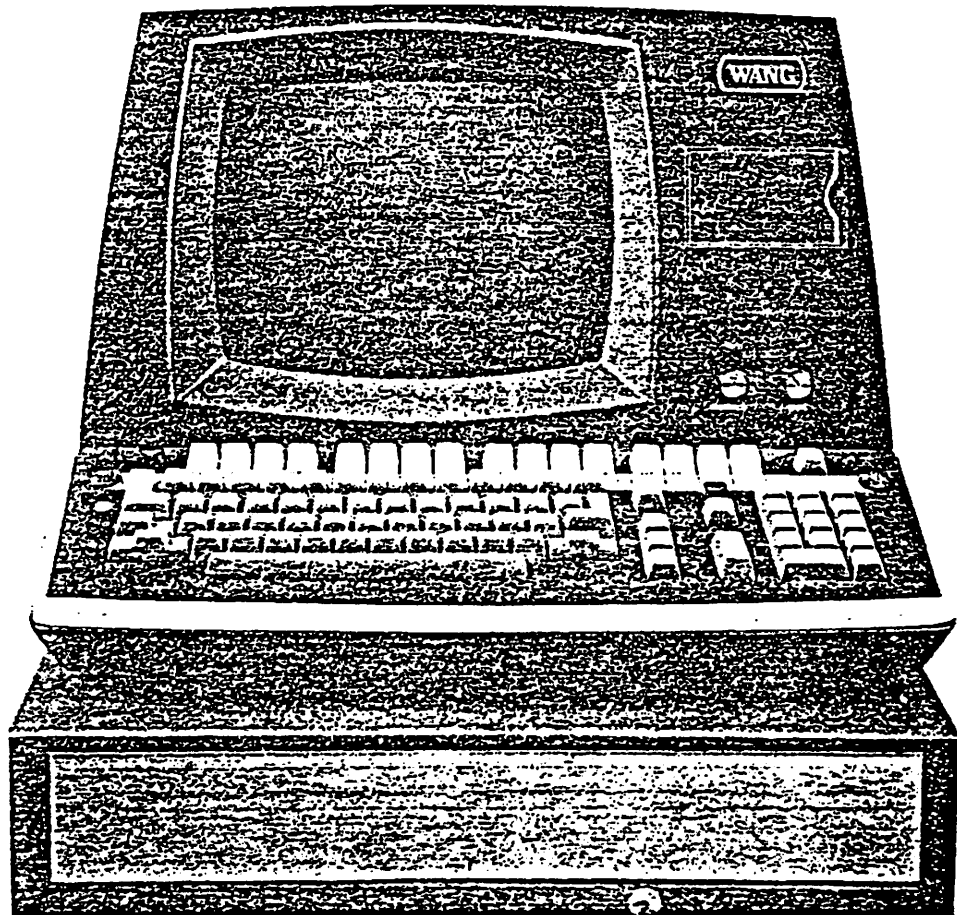
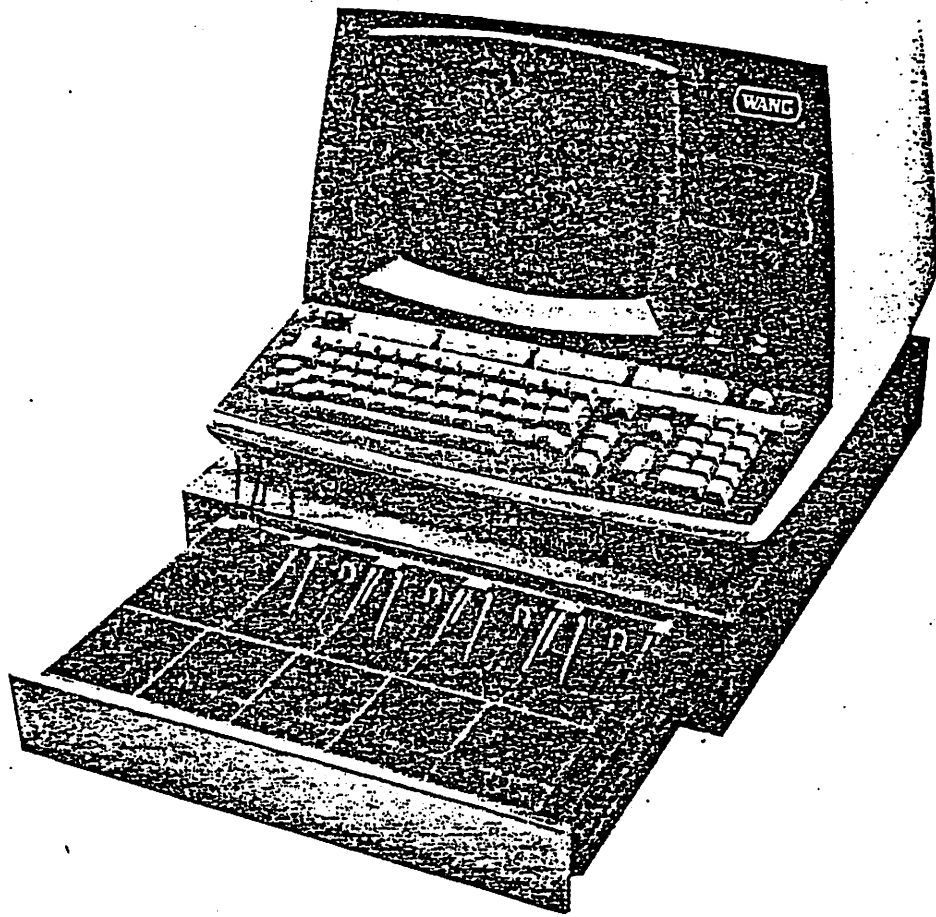
TESTING 2200VP BASIC-2

GENERAL I/O

SPACK
INTERNAL FORMAT.....OKAY
DELIMITER FORMAT
FIELD FORMAT
MISCELLANEOUS

SUNPACK
INTERNAL FORMAT.....OKAY
DELIMITER FORMAT
FIELD FORMAT

4.5 2236D SELF TEST

The 2236D microcode has some interesting properties that make it useful as a quick self-check of the terminal hardware. As part of communication protocol between the terminal and the MXD, the terminal identifies itself 2236D to enable the MXD's space compression feature.

The 2236D can be tested by installing a loopback connector on the rear of the terminal. When the 2236D is turned ON, the 2236D Microcode will display certain characters.

Wire an RS-232 loop back connector as follows:

Pin No.	2	3	4	5	6	20
Signal	Txdata	Rxdata	RTS	CTS	DSR	DTR

Install the loopback connector, then turn the 2236D on. With no printer plugged in, press RESET. If the CRT controller accepts data from the microprocessor, the characters

i x

should appear on the screen.

Connect a printer (or null printer plug described below) to the remote printer jack on the back of the terminal. Make sure the printer is ON and SELECTED. Press RESET on the terminal. If the printer controller is accepting data from the microprocessor, the characters

i x y

will appear on the CRT.

Deselect the printer. Press RESET. The CRT should read:

i x y

Press RESET again. The CRT should read:

i x

Null printer plug:

Connect pin 1 to pin 10

Connect pin 11 to pin 29

Now test the rest of the keyboard. The letters and numbers should appear correctly on the screen. SPACE should produce a space and BACKSPACE should move the cursor to the left without blanking any character.

The special function keys should appear as the underlined uppercase alphabet, starting with SF'0 = underlined @.

These few simple tests check

- 1) The keyboard
- 2) The CRT controller
- 3) The UART
- 4) The printer controller ready/busy

They do not test

- 1) The validity of the data sent to the printer
- 2) The blinking cursor
- 3) The CRT beeper
- 4) The hardware/firmware parity check logic