

WANG

IV.A.3.



**2200
SYSTEMS
OPTION
"C"**



**Selfstudy
Workbook**



729-1062

CUSTOMER ENGINEERING TECHNICAL TRAINING CENTER





!! IMPORTANT NOTICE !!

* * * * *
* Upon completion of this course you are *
* eligible to receive a completion of train- *
* ing certificate. To receive the certifi- *
* cate, please complete and return the Self- *
* Study "Course Completion Form" located on *
* the next page. No postage is requieed if *
* the form is mailed in the United States. *
* Your input is vital, it will be used by *
* the Technical Training Center to update *
* and determine the effectiveness of this *
* training material. The continued exist- *
* ance of this Self-Study Workbook and add- *
* itional Workbooks to be developed will be *
* determined by the feedback that the Tech- *
* nical Training Center recieves from YOU. *
* * * * *

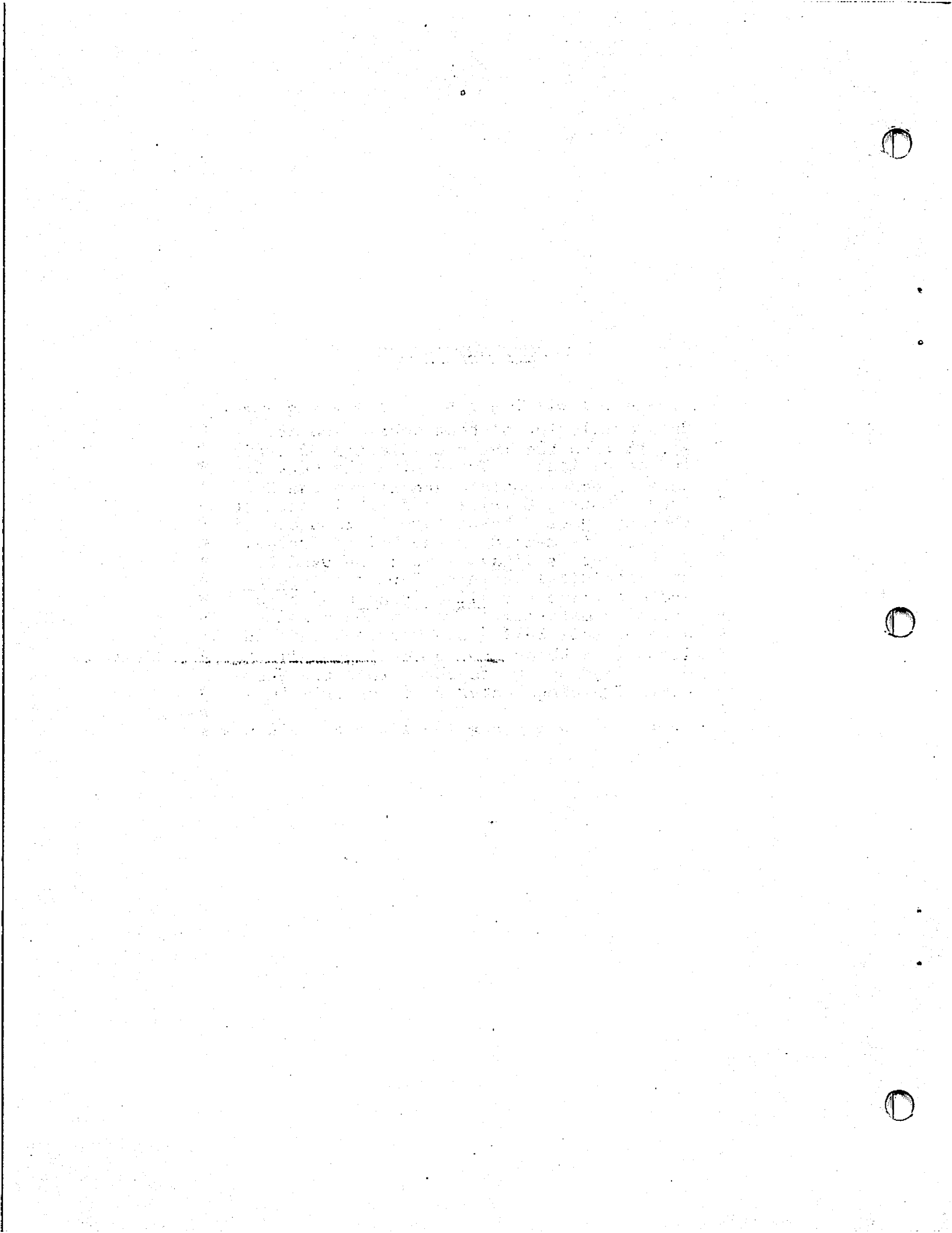

SELF-STUDY COURSE COMPLETION FORM

NAME _____

YOUR MANAGER'S SIGNATURE _____

RDB NUMBER _____ PHONE NUMBER (_____) _____

MAILING ADDRESS _____

WORKBOOK TITLE _____

WORKBOOK REVISION NUMBER _____ DATE OF COMPLETION _____

STUDENT CRITIQUE OF TRAINING

For each of the statements below, please mark one of the letter-codes which best indicates how you feel about that statement:

SD	D	A	SA
STRONGLY DISAGREE	DISAGREE	AGREE	STRONGLY AGREE

- | | | | | |
|---|----|---|---|----|
| 1. The Objectives and Scope of the course were clearly explained. | SD | D | A | SA |
| 2. The Course Material was presented in a logical, sequential manner. | SD | D | A | SA |
| 3. I was able to understand the Course Material. | SD | D | A | SA |
| 4. The Quizzes were a reasonable measure of my understanding. | SD | D | A | SA |
| 5. The Course helped me to be comfortable with the equipment. | SD | D | A | SA |
| 6. The Course provided the Basic Knowledge and Skills required for my work. | SD | D | A | SA |

COMMENTS/QUESTIONS/*CORRECTIONS _____

* (If a correction is indicated above please include effected page numbers along with the necessary correction.)

Do you desire an answer to your comments/questions? ____ Yes ____ No

THANK YOU FOR YOUR ASSISTANCE



Fold



**NO POSTAGE
NECESSARY
IF MAILED
IN THE
UNITED STATES**

BUSINESS REPLY CARD
FIRST CLASS PERMIT NO. 16 LOWELL, MA

POSTAGE WILL BE PAID BY ADDRESSEE

**WANG LABORATORIES, INC.
TECHNICAL TRAINING CENTER
431 SO. UNION STREET
LAWRENCE, MASSACHUSETTS 01843**



Cut along dotted line

**ATTENTION: Curriculum Development
Supervisor M/S 8530**

Fold

“This document and the information it contains are the confidential property of, and are proprietary to, Wang Laboratories, Inc. This document and the information it contains may not be made public without the written consent of Wang Laboratories, Inc. If for any reason this document is permitted by Wang to leave the physical custody of the company, it is returnable upon the demand of Wang Laboratories, Inc.”

2200 MVP OPTION “C”

2200 LVP OPTION “C”

with

QUANTUM DISC DRIVE

**SELF-STUDY
MAINTENANCE**

Revision 1.2

CUSTOMER ENGINEERING TECHNICAL TRAINING CENTER

NOTES

FORWARD

This self-study course is designed to aid the student in his goal of being able to install and maintain the WANG 2200 MVP with Option "C" and the 2200 LVP Option "C" with the optional Quantum Disk Drive. It is assumed the student has already been trained on the WANG 2200 MVP/LVP. It is recommended that the student start at Section 1 and proceed thru Section 7 of the workbook.

COURSE STRUCTURE

The course consists of seven sections described below.

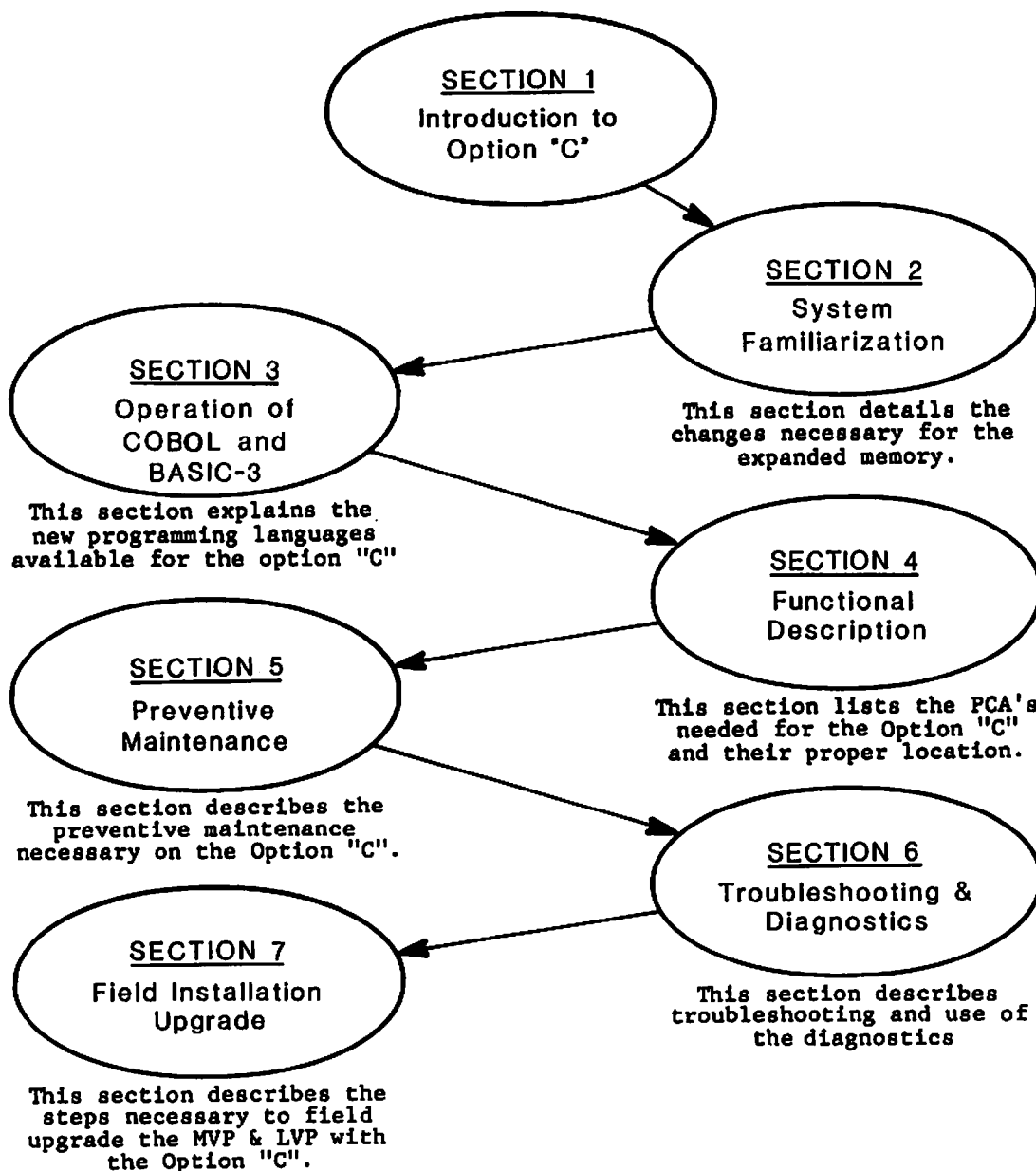

COURSE OBJECTIVES

Upon completion of the Self-Study Workbook, the student will be able to:

1. Install the MVP and LVP with Option "C".
2. Upgrade existing MVP & LVP units in the field with the option "C"
3. Install the Quantum Disk Drive in the LVP and check for correct operation.
4. Troubleshoot the MVP or LVP with Option "C" and isolate any problem to the defective Printed Circuit Board or Disk Drive using the Diagnostics.

TABLE of CONTENTS

Section 1	INTRODUCTION	page 1-1
Section 2	SYSTEM FAMILIARIZATION	page 2-2
	2.1 Introduction	page 2-2
	2.2 Motherboard changes	page 2-2
	2.3 Data memory changes	page 2-2
	2.4 Control memory changes	page 2-4
	2.5 Instruction counter	page 2-4
	2.6 Extended memory controller	page 2-6
	2.7 Quantum disk drive	page 2-7
	2.8 LVP Quantum hardware changes	page 2-8
Section 3	OPERATION of COBOL & BASIC-3	page 3-1
	3.1 Introduction to COBOL	page 3-1
	3.2 Introduction to BASIC-3	page 3-1
Section 4	FUNCTIONAL DISCRIPTION	page 4-1
	4.1 Boards used in the MVP/LVP Option "C"	page 4-1
	4.2 MVP motherboard configuration	page 4-1
	4.3 LVP motherboard configuration	page 4-2
Exercise 1	page EX 1-1
Answers to Exercise 1	page EX 1-2
Section 5	PREVENTIVE MAINTENANCE	page 5-1
	5.1 Quantum preventive maintenance.....	page 5-1
	5.2 MVP/LVP preventive maintenance.....	page 5-1
Section 6	TROUBLESHOOTING & DIAGNOSTICS	page 6-1
	6.1 Use of diagnostics	page 6-1
Section 7	FIELD INSTALLATION UPGRADE	page 7-1
	7.1 Removal of MVP chassis	page 7-1
	7.2 Installation of new MVP chassis	page 7-1
	7.3 Voltage adjustments of MVP	page 7-3
	7.4 Removal of LVP chassis	page 7-4
	7.5 Installation of new LVP chassis	page 7-5
	7.6 Voltage adjustments of LVP	page 7-6
	7.7 LVP voltage adjustment locations	page 7-6
	7.8 Quantum disk drive installation	page 7-7
	7.9 Quantum spindle lock clip	page 7-8
	7.10 Quantum actuator lock	page 7-9
	7.11 Quantum jumper options	page 7-9
	7.12 Quantum control line termination	page 7-10
	7.13 Quantum shipping instructions	page 7-10
	7.14 Quantum switch settings 8696 Bd.	page 7-11
Exercise 2	page EX 2-1
Answers to Exercise 2	page EX 2-2

APPENDICES

Revision Log	Appendix "A"
--------------------	--------------

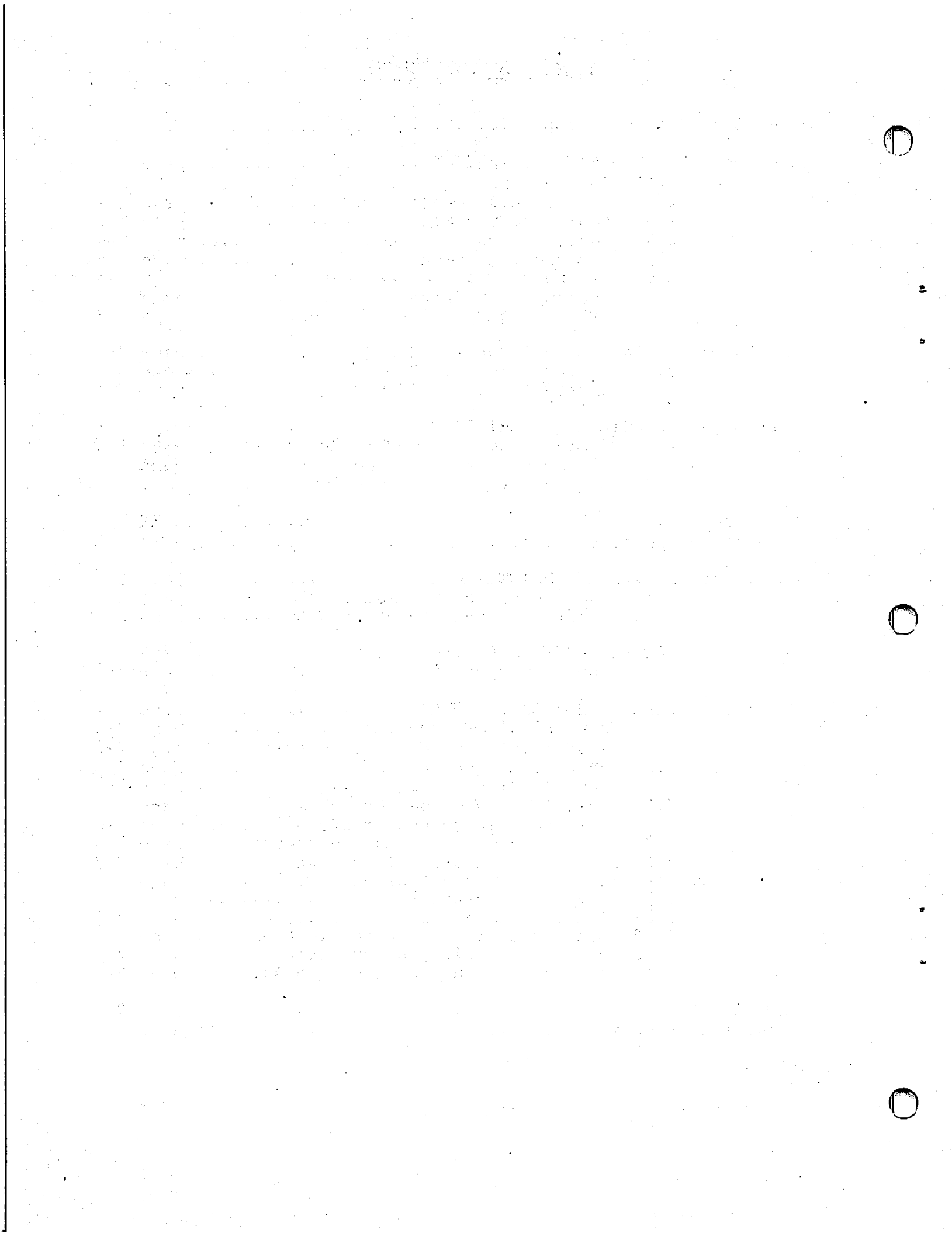

Section 1 **INTRODUCTION**

The WANG 2200 Option "C" provides the 2200 LVP, MVP system with increased memory needed to support both COBOL and BASIC-3 languages. Included with the Option "C" are a multi-user operating system with disk volume and file management capabilities.

In addition the customer can select either the standard Shugart SA 1000 disk drive or the new QUANTUM Disk Drive. The QUANTUM will only be available for option "C" LVP's

SECRET

The following information was obtained from a review of the files of the Central Intelligence Agency, Office of the Director of Central Intelligence, regarding the activities of the [redacted] in the [redacted] area during the period [redacted] to [redacted].

The [redacted] was identified as a [redacted] of the [redacted] and was active in the [redacted] area during the period [redacted] to [redacted].



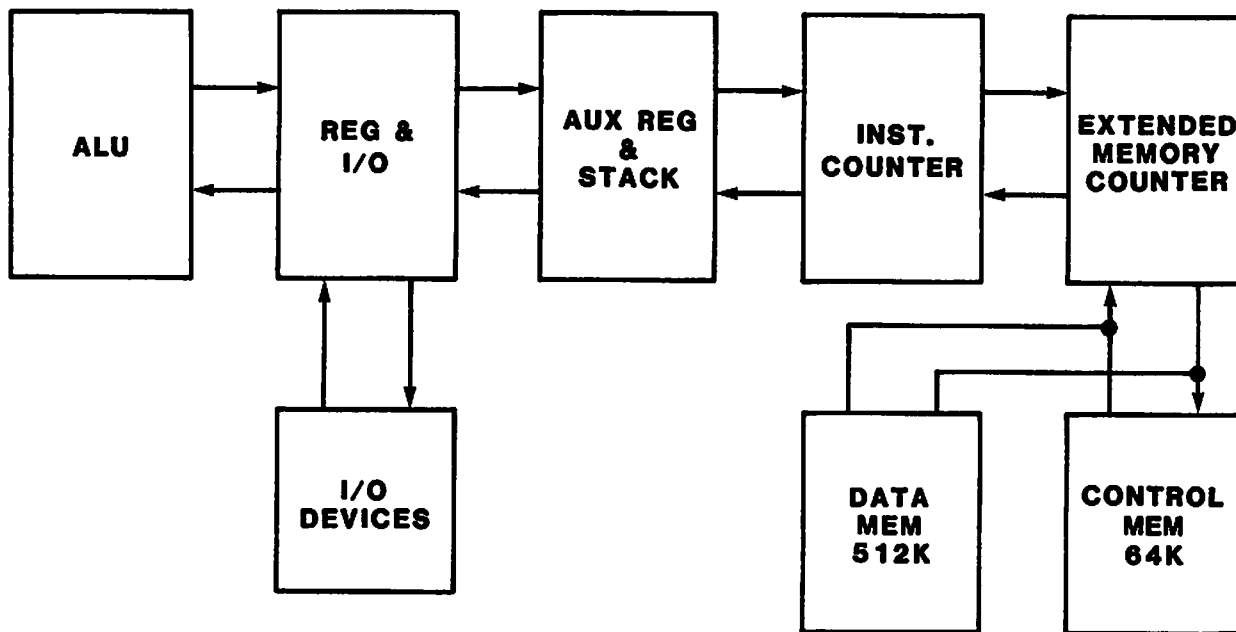

BASIC BLOCK DIAGRAM MVP/LVP OPTION C
fig. 2-1

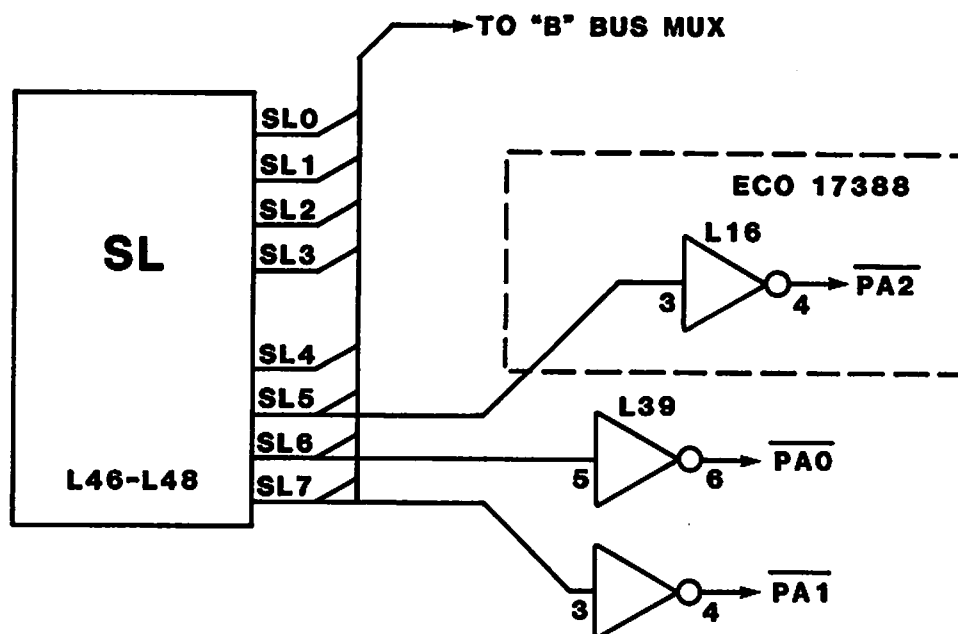

REGISTER BOARD #210-6793 WITH ECO 17388
fig. 2-2

Section 2 SYSTEM FAMILIARIZATION

2.1 OPTION "C"

The 2200 memory has been increased as follows:

Control Memory - from 32K to 64K

Data Memory - from 256K to 512K

In order to expand the 2200 system memory, the following changes were added to the existing configuration.

2.2 Motherboard changes:

New motherboards are need to accomodate the two additional memory boards and the new Extended memory controller board. The new motherboards now have seven I/O slots.

MVP Motherboard #7798

LVP Motherboard #7799
(with ECO 20404 for use with Quantum Drive)

2.3 Data Memory changes:

Note: Block Diagram of changes on page 2-1, fig. 2-1

In order to increase the Data Memory from 256K to 512K an additional address bit is needed. This bit is "SL5" on the Register Board (6793). This bit is inverted and sent out as PA2. A spare 7404 inverter (L16-3,4) is used to invert SL5. PA2 is then brought out on the motherboard at pin 19-2 of the 6793 board. This change (ECO #17388) is transparent to all existing 2200 motherboards. (ECO #17388 is shown in fig 2-2 on page 2-1).

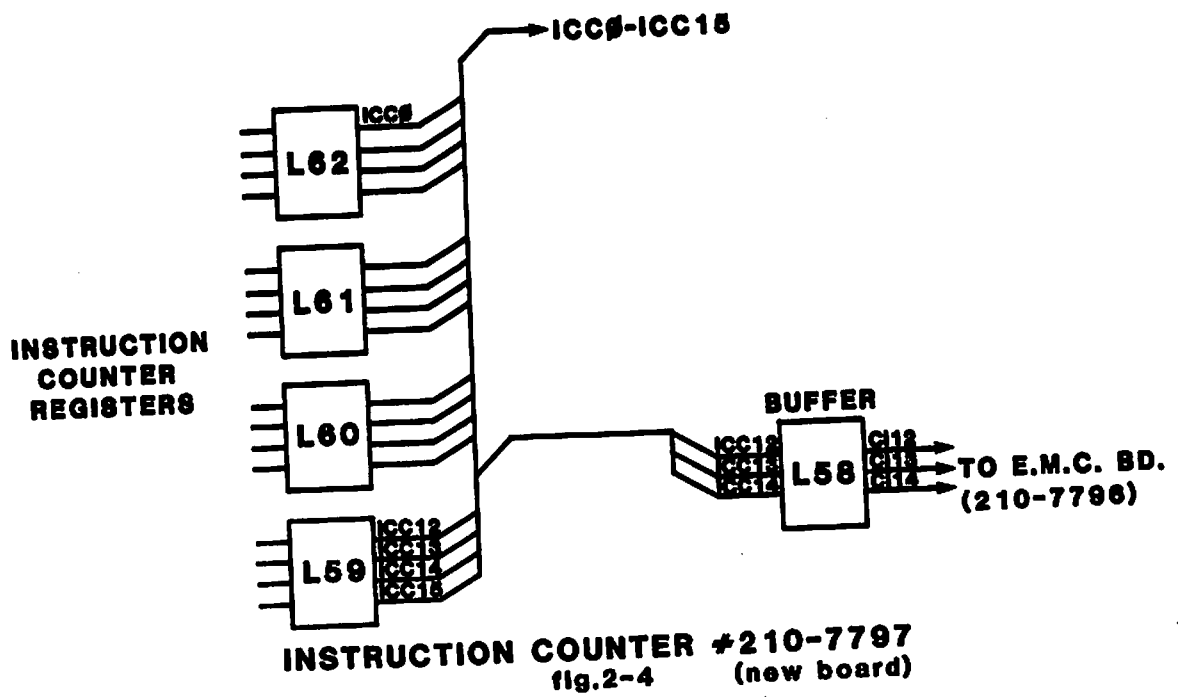
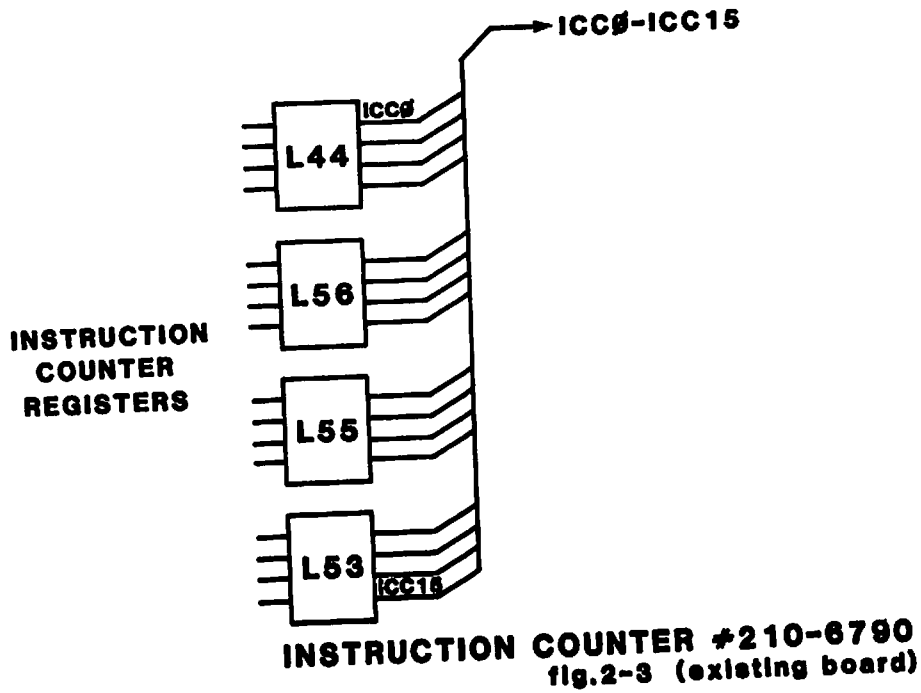

2.4 Control Memory changes:

Additional address decoding is also needed to increase the Control Memory from 32K to 64K. To accomplish this a new Instruction Counter Board will be used, and the address selection bits (MS1 - MS8) formally decoded on the instruction counter board will now be decoded on the new Extended Memory Counter board.

2.5 Instruction Counter:

The new Instruction Counter Bd. (#210-7797), is similar to the 6790 Instruction Counter Board except that MS1 - MS8 is decoded off the board. To do this IC12 - IC14 is buffered and brought out as CI12 - CI14 (see figures 2-3, 2-4).

(Note: IC15 is buffered and becomes the signal $\overline{\text{ROMS}}$ on the Extended Memory Controller Board)

These bits are then decoded as the most significant bits on the Extended Memory Counter Board 7796 (see fig 2-5). This Instruction Counter Board will only work on Extended Memory 2200's. All other 2200's require the use of the 6790 board.

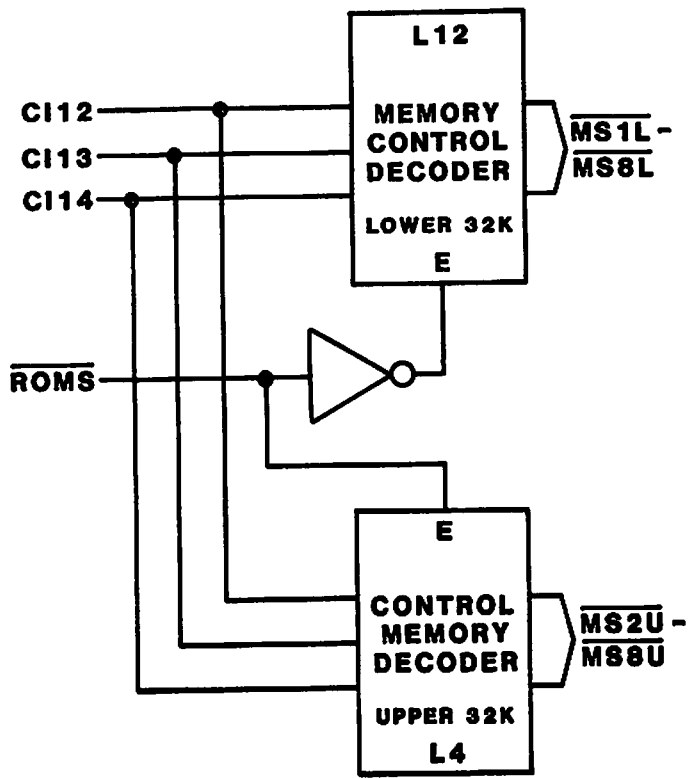

CONTROL MEMORY SELECT
fig. 2-5

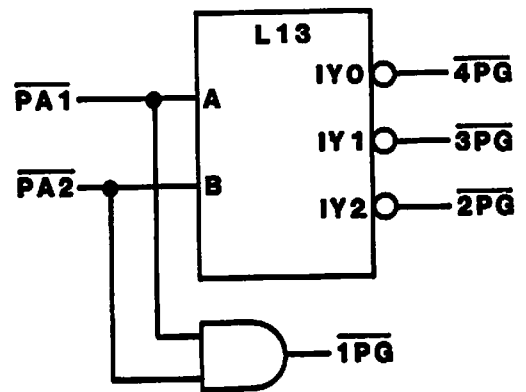

DATA MEMORY BOARD SELECT
fig. 2-6

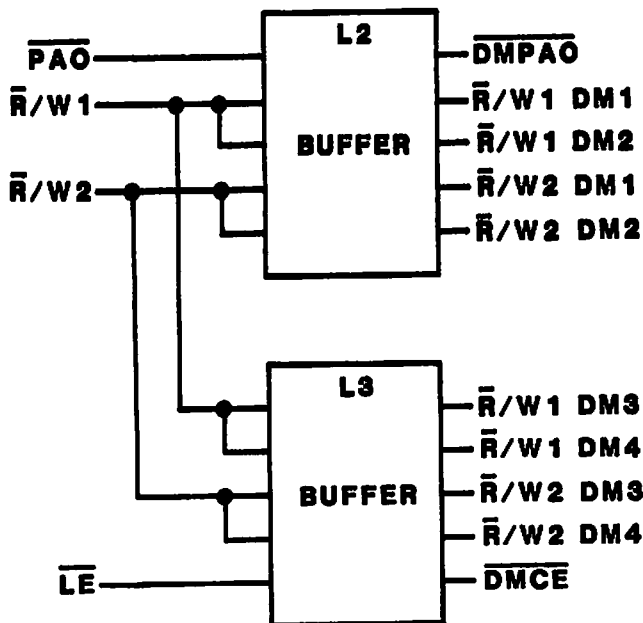

DATA MEMORY READ/WRITE CONTROL
fig. 2-7

BLOCK DIAGRAM EXTENDED MEMORY CONTROLLER #7796

2.6 Extended Memory Controller:

The extended Memory Controller Board (7796) will perform the memory selection for both data and control memory. (A block diagram is located on the page 2-5).

A. Data Memory - The 512K of data memory is structured as four 128K pages. These pages are selected on the Extended Memory Counter board as follows:

<u>PA2</u>	<u>PA1</u>	<u>Selection bit</u>	<u>Memory size</u>
0	0	4PG	128K
0	1	3PG	256K
1	0	2PG	384K
1	1	1PG	512K

(see figure 2-6)

B. Control Memory - (figure 2-5) The CI12 - CI15 bits from the Instruction Counter board are used to decode either the lower or upper 32K of memory. The lower 32K is selected by the signal "ROMS" being off and the upper 32K by "ROMS" being on. (the signal ROMS is the CI15 signal inverted). The first 4K of upper memory is dedicated to the system "bootstrap". This hole in memory is achieved by having CI 12 - CI 15 off and "ROMS" on. Control memory is configured as follows:

<u>Address</u>		<u>Memory Size</u>
FFFF	Upper Memory	28K
9000		

8FFF	Bootstrap Prom	4K
8000		

7FFF	Lower Memory	32K
0000		

C. Data Memory Read/Write Control

The Data Memory Read/Write control is now located on the Extended Memory Counter (see fig. 2-7).

2.7 QUANTUM DISK DRIVE

The Quantum 8" Fixed Disk Drive is a direct replacement for the Shugart SA 1000 series currently being shipped with 2200 LVP systems. The Quantum is Winchester technology and has the following capacities.

Manufactured by : Quantum Corp.
1804 McCarthy Blvd.
Milpitas Calif.

Moveable heads and rotary disks enclosed in an impact resistant plastic and aluminum pressure equalized bubble.

* Heads land on track 511 when power is off.

* Rotational speed is 3000 RPM.

* Data transfer rate 4.34 Mbit/sec.

* AC Power Requirements: 90-127 VAC at 1.0 amps

* DC Power Requirements: +24 V + or - 10%, @ 1.5A
+5 V + or - 5%, @ 1.0A
-5 V + or - 5%, @ 0.5A
Max ripple = 50 mV P-P

* Environmental Operating Limits

Ambient Temp. 50 to 115 degrees F

Relative Humidity 8 to 80%

Maximum Wet Bulk Temperature = 78 degrees F

* Q-2020 - 20 MB of unformatted and 16 MB of formatted data utilizing 2 fixed platters. (WANG part # 725-0119)

512 cylinders
4 surfaces
2048 tracks
32 sectors per track
4 Read/Write heads

* Q-2040 - 40 MB of unformatted and 32 MB of formatted data utilizing 4 fixed platters. (WANG part # 725-0120)

512 cylinders
8 surfaces
4096 tracks
32 sectors per track
8 Read/Write heads

2.8 LVP QUANTUM HARDWARE CHANGES

The following changes to the 2200 LVP option "C" are necessary to utilize the Quantum drive.

- 1.) The extended Memory Motherboard PN 210-7799 will be modified with ECO 20404
- 2.) The Fixed/Floppy Interface Board # 8694 will be replaced by a new #210-8794 Fixed/Floppy Interface Board.
- 3.) The Controller board #8695 will be replaced by a new #210-7925 Controller Board.

NOTES

0371



Section 3 **OPERATION of COBOL & BASIC-3**

3.1 Introduction to COBOL

COBOL (COmmon BUssiness ORiented Language) is one of the most popular programming languages. It is heavily used in business applications that require repetitious updating of files. It is also used for applications whose goal is to maintain up-to-date information that can be used as input to other processing, including report generation. Some of the benefits of COBOL as a programming language are:

- 1.) COBOL is subject to industry-wide standards administered by the American National Standards Institute (ANSI). Therefore, COBOL is highly compatible among manufacturers.
- 2.) Since statements in COBOL are analogous to those in ordinary English, COBOL programs can be written so that they are relatively easy to read, as compared to programs in other languages
- 3.) COBOL provides an array of useful record formatting, data manipulation, and file handling capabilities that are particularly important for data processing applications.
- 4.) As a major computer language, COBOL already has a pool of trained programmers and analysts.

3.2 Introduction to BASIC-3

WANG 2200 BASIC-3 is a general purpose high level programming language being developed by WANG Laboratories for use on the 2200 series of Central Processing Units. BASIC-3 is a modified version of the original Dartmouth BASIC language which offers all the important features of the original BASIC as well as new features and enhancements implemented by WANG. The result is a programming language which is powerful, extremely versatile, and well suited for both technical and commercial applications. BASIC-3, like the original BASIC and BASIC-2, is designed to be easily learned by beginning programmers.

BASIC-3 will be offered as a stand-alone language or co-resident with 2200 COBOL. COBOL will not be offered alone since BASIC-3 is viewed as a necessary utility language.

Note: Additional information may be obtained by ordering the "2200 COBOL/BASIC-3 TECHNICAL BULLETIN" WANG part #700-6784.

Section 4 FUNCTIONAL DESCRIPTION

4.1 List of boards required for the 2200 Option "C" MVP & LVP systems.

	Option "C" MVP	Option "C" LVP with Quantum
Disk Interface	n/a	8794
Disk CPU	n/a	8696
Disk Controller	n/a	7925
Register Bd.	6793-1 (note 1)	6793-1 (note 1)
ALU	6792	6792
Stack	6791	6791
Instruction Cntr.	7797	7797 REPLACES 6790 SD.
Memory Control	6789	6789
Control Mem Upper	7588	7588
Control Mem Lower	7588	7588
Ext. Mem Control	7796	7796
Date Memory 1	7587	7587
Date Memory 2	7587	7587
Date Memory 3	7587	7587
Date Memory 4	7587	7587
Motherboard	7798	7799 (note 2)

note 1 modified with ECO 17388
 note 2: modifies with ECO 20404

4.2 MVP Board layout

PC Boards are inserted in the MVP Motherboard as follows:

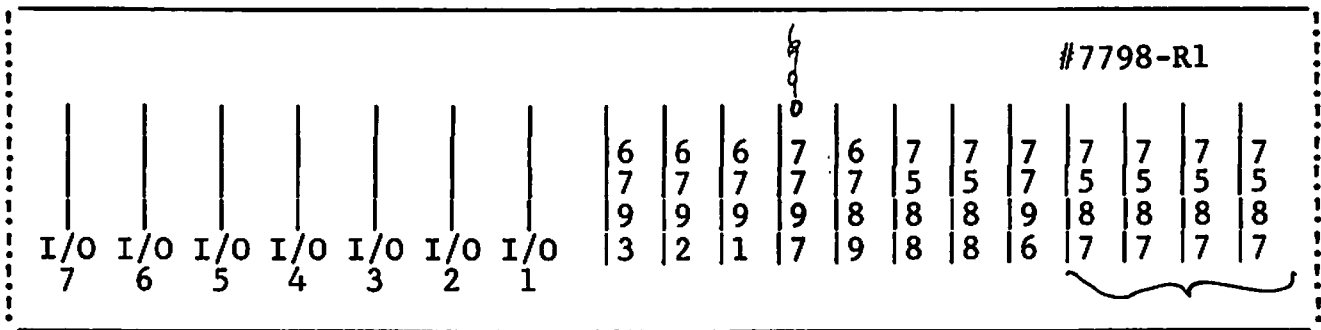

4.3 LVP Board layout

PC Boards are inserted in the LVP Motherboard as follows:

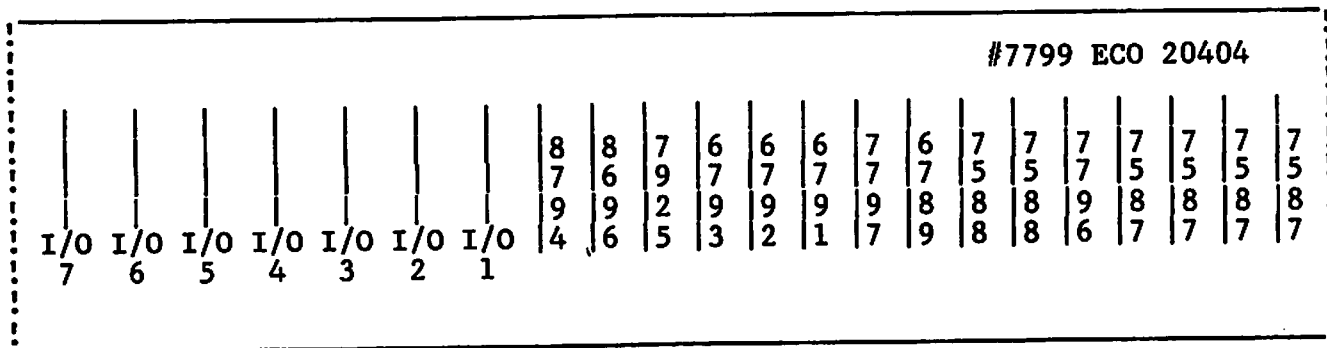

EXERCISE 1

To ensure that you understand the information presented in this workbook thus far, please complete the following exercise.

1. WANG Laboratories offered the Option "C" so as to:
 - a. Enable users to run COBOL and BASIC-3.
 - b. Enable users to have greater memory capacity.
 - c. Both of the above.

2. Memory size is now increased from 32K to _____ for control memory and from 256K to _____ for data memory.

3. List the new PCA's used for the Option "C".

	<u>MVP</u>	<u>LVP</u>
Motherboard	_____	_____
Disk Interface	N/A	_____
Disk Controller	N/A	_____
Ext. Mem. Contr.	_____	_____
Instruction Cntr.	_____	_____

Note: Answers may be found on page EX 1-2

ANSWERS to EXERCISE 1

1. c
2. Memory size is now increased from 32K to 64K for control memory and from 256K to 512K for data memory.
3. List the new PCA's used for the Option "C".

	<u>MVP</u>	<u>LVP</u>
Motherboard	<u>7798</u>	<u>7799</u>
Disk Interface	<u>N/A</u>	<u>8794</u>
Disk Controller	<u>N/A</u>	<u>7925</u>
Ext. Mem. Contr.	<u>7796</u>	<u>7796</u>
Instruction Cntr.	<u>7797</u>	<u>7797</u>

NOTES

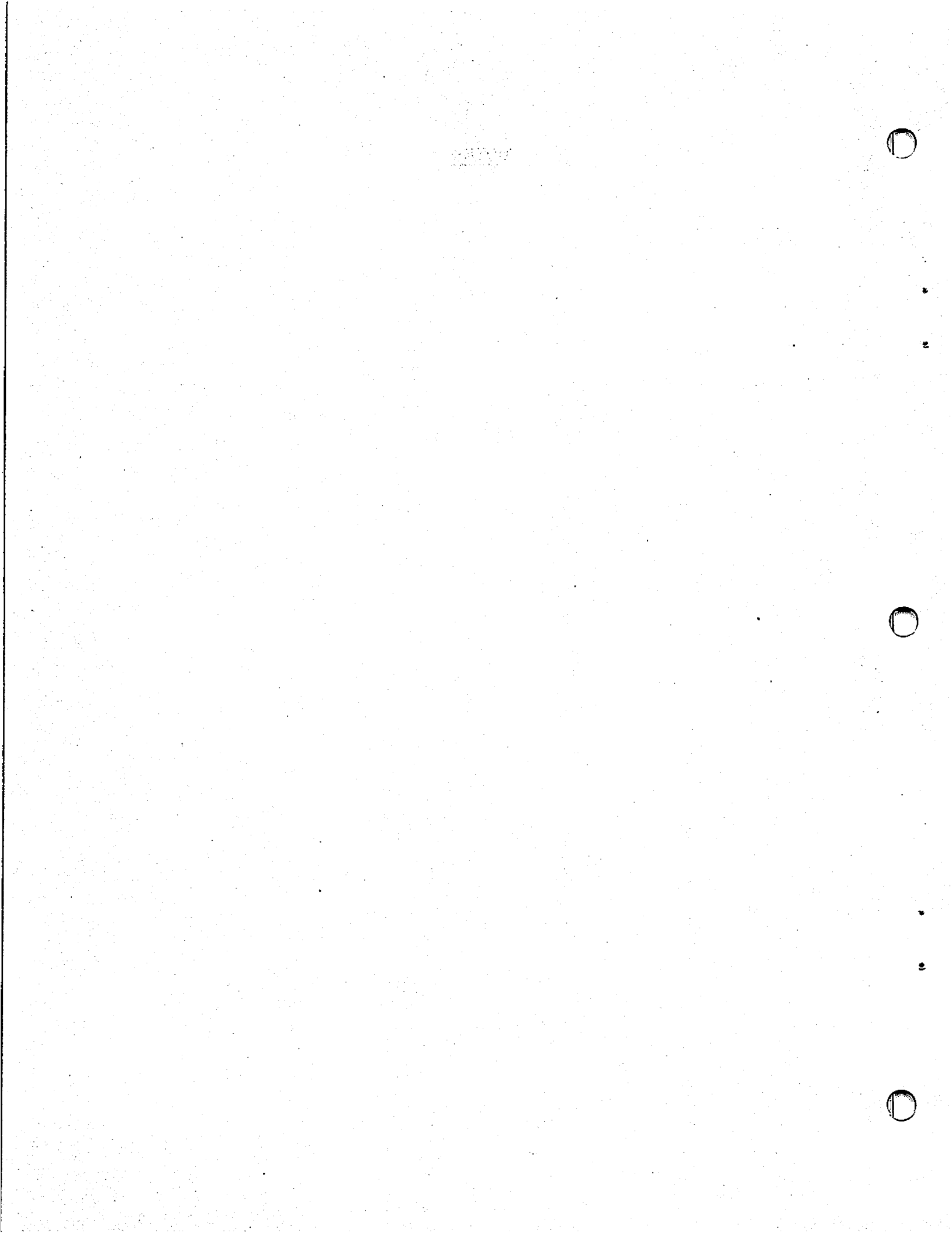

Section 5 PREVENTIVE MAINTENANCE

5.1 QUANTUM DISK DRIVE

The Quantum drive is enclosed in an impact resistant plastic and aluminum pressure equalized bubble. No preventive maintenance is required.

5.2 MVP/LVP

The preventive maintenance procedures are the same as previous units, refer to the following maintenance manuals.

MVP WANG Part # 729-0584

LVP WANG Part # 729-0602

NOTES

Section 6 **TROUBLESHOOTING & DIAGNOSTICS**

- 6.1 To facilitate troubleshooting of the 2200 MVP, & LVP with the Option "C" the diagnostics have been revised to test the new expanded memory. The following is a list of the necessary Documentation and Software part numbers:

SOFTWARE DOCUMENTATION:

2200 CPU Diagnostics

Date: 12 August 1981

Documentation Release: Rev. 9170 or higher

Software Release: Rev. 1170 or higher

SOFTWARE DISKETTES

Part Number: 702-0138 (2270A for single density media)

732-0010 (SA-850 for double density media)

732-0002 (Diskette to test DSDD Drives)

In addition the Customer Engineer will need a Maintenance Manual for the system under test.

NOTES

Section 7 **FIELD INSTALLATION UPGRADE**

FIELD INSTALLATION OF OPTION "C" INTO AN EXISTING 2200 MVP

The updated MVPC chassis will be equipped with a power supply minus the regulator board. The regulator board removed from the old chassis will be used.

7.1 Removal of MVP Chassis

1. Set the power toggle switch to the OFF position on the CPU and all peripheral units. Remove the power cable from its receptacle.
2. Disconnect all cables used for peripherals from the I/O controller boards.
3. Remove four screws that secure the printed circuit board cover. Set the chassis/motherboard assembly on a table top. Remove all existing boards including the power regulator board 210-7397. Set the old MVP chassis aside.

7.2 Replacement of new MVPC Chassis

1. Set the new MVPC chassis with the carrying handle facing up (operating position). Remove the front and rear covers.
2. Load the power regulator board 210-7397 from the front into the correct slot on the motherboard.
3. Turn power switch ON, and check all voltages as per section 7.3 to ascertain that all voltages are present prior to loading circuit boards.

4. If No-Load voltage indications are ok, turn power OFF and proceed to install circuit boards (both reusable and new boards from the kit) except for the controller boards into their respective slots on the motherboard. Use care to ensure that each board is in its correct slot and properly seated. (see page 4-1 for board layout).

5. Turn power ON and recheck voltages at the same points.

NOTE

Adjust the voltages in the order listed for the MVPC vs the MVP systems.

If any of the voltages are missing or do not react to adjustment, prepare to remove all boards and insert them one at a time until the problem reappears, then troubleshoot.

6. If all voltages adjust properly, add one controller board for the 2236DE workstation. Load and run the diagnostics and data entry required for checking the operation of the MVPC.

7. Once the system is checked and operating properly, load the remaining I/O boards, then check and adjust voltages

8. Cable all peripherals to their respective controller. Replace the board clamp on the new chassis. Replace the front and rear covers.

7.3 Voltage Adjustments MVP & MVP Option "C" Systems

The voltage adjustments require that both front and rear covers be removed. The regulator board (210-7397) is used on both the standard MVP and the MVP Option "C" systems. However there is a difference in the response when adjusting the +5V I/O and the +5V Logic voltages for each system. Proceed to check and adjust these voltages in the suggested order. Interaction of voltage adjustments will require rechecking and adjustment.

Standard MVP Voltage Adjustment Sequence

-12V -5V +12V +5V Logic +5V I/O

Option "C" MVP Voltage Adjustment Sequence

-12V -5V +12V +5V I/O +5V Logic

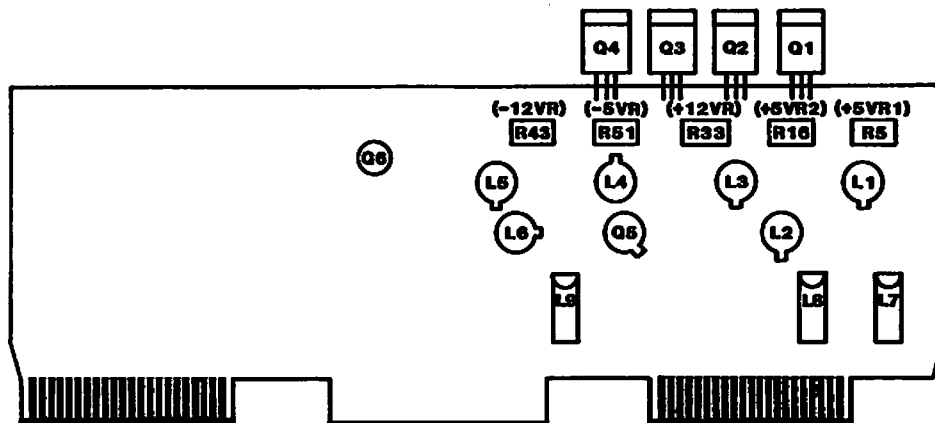

7397 REGULATOR BOARD

LOCATION	VOLTAGE	LIMITS	ADJUST	RIPPLE
			7397 Bd.	
Pin J ₁	+5VR1	+4.95 vdc to +5.05 vdc	R5	15 mvp-p
Pin L ₁	+5VR2	+4.95 vdc to +5.05 vdc	R16	15 mvp-p
Pin M ₁	+12VR	+11.95 vdc to +12.05 vdc	R33	15 mvp-p
Pin N ₁	-12VR	-11.95 vdc to -12.05 vdc	R43	35 mvp-p
Pin S ₁	-5VR	-4.95 vdc to -5.05 vdc	R51	25 mvp-p

CPU VOLTAGE REGULATOR ADJUSTMENTS

FIELD INSTALLATION OF THE OPTION "C" INTO THE 2200 LVP

7.4 Removal of LVP Chassis

1. Turn power OFF and unplug power cable.
2. Remove the top cover of the cabinet for access by removing the two screws from the rear-underneath sides of the top cover using a 5/16 " nut driver. Lift the top cover out of the two snap locks and set it aside.
3. Remove the lower back panel that covers the rear of the power supply by removing the four (4) hex screws.
4. Disconnect the Power Supply Harness connector which attaches to the 6-pin Mat-'N'-Lock connector on the power supply. (Note: Pictures of cable locations are available in the LVP Maintenance Manual on pages 8-17 thru 8-21.)
5. Disconnect the Power Supply Harness which attaches to the 10-pin Molex connector on the power supply.
6. Remove cable assembly (220-1405) connector from the bottom of the motherboard (J2).
7. Remove the three ribbon connectors from the top edge of the motherboard (connectors 1, 2, and 3) that attach to the disk drives.
8. Unplug cable assembly (220-1425) from fixed power supply cable connector that supplies power to the cooling fan.
9. Disconnect cable assembly (220-1423) connector to front panel indicators.
10. Remove card cage cover on CPU chassis. Remove existing PCA's and carefully set them aside for installation in the new chassis.
11. Remove the four screws from the rear of each corner of the CPU chassis. Lift the chassis and remove it from the cabinet and set the chassis aside.

7.5 LVP CPU Chassis Replacement

1. Replace the new CPU chassis with the original four screws and tighten with the nut driver.
2. Reconnect power connectors except for cable assembly 220-1405 which connects to J2 of the motherboard (DC power and control harness to disk drive)
3. Plug in cabinet power cable and turn power switch ON. Insure that both cooling fans are operating. Measure DC voltages at test points on the motherboard. If all voltages are present, turn power OFF.
4. Complete cabling-up by plugging the cable assembly 220-1405 into J2 of the new motherboard and replace the ribbon cables on the top edge connectors of the new motherboard. The fixed disk drive has two ribbon connectors that attach to connector 2 (50 pin) and connector 3 (20 pin) and the floppy disk drive ribbon connector attaches to connector 1 (50 pin).
5. Insert all reuseable and new boards from the kit into their proper connectors as illustrated on page 4-2. Insert one I/O terminal controller for the data entry workstation 2236 DE. The workstation will be used for checking the CPU.
6. Turn power ON and adjust operating voltages within the tolerances specified on page 7-6.
7. Bring system up and load diagnostics for testing the new chassis assembly.

7.6 LVP Voltage Specifications

<u>Voltage</u>	<u>Limits</u>
+5V1 (note 1)	+4.95 to +5.05 V
+5V2 (note 2)	+4.95 to +5.05 V
+12V	+11.95 to +12.05 V
+24V	+21.60 to +24.60 V
-5V	-4.95 to -5.05 V
-12V (note 3)	-11.50 to -12.50 V

- * note 1 If +5V1 drops below +4.70 VDC, the +24V will shut off
- * note 2 +5V2 supplies voltages for the four additional I/O slots.
- * note 3 -12V is not adjustable.

7.7 Power Supply Adjustment Locations

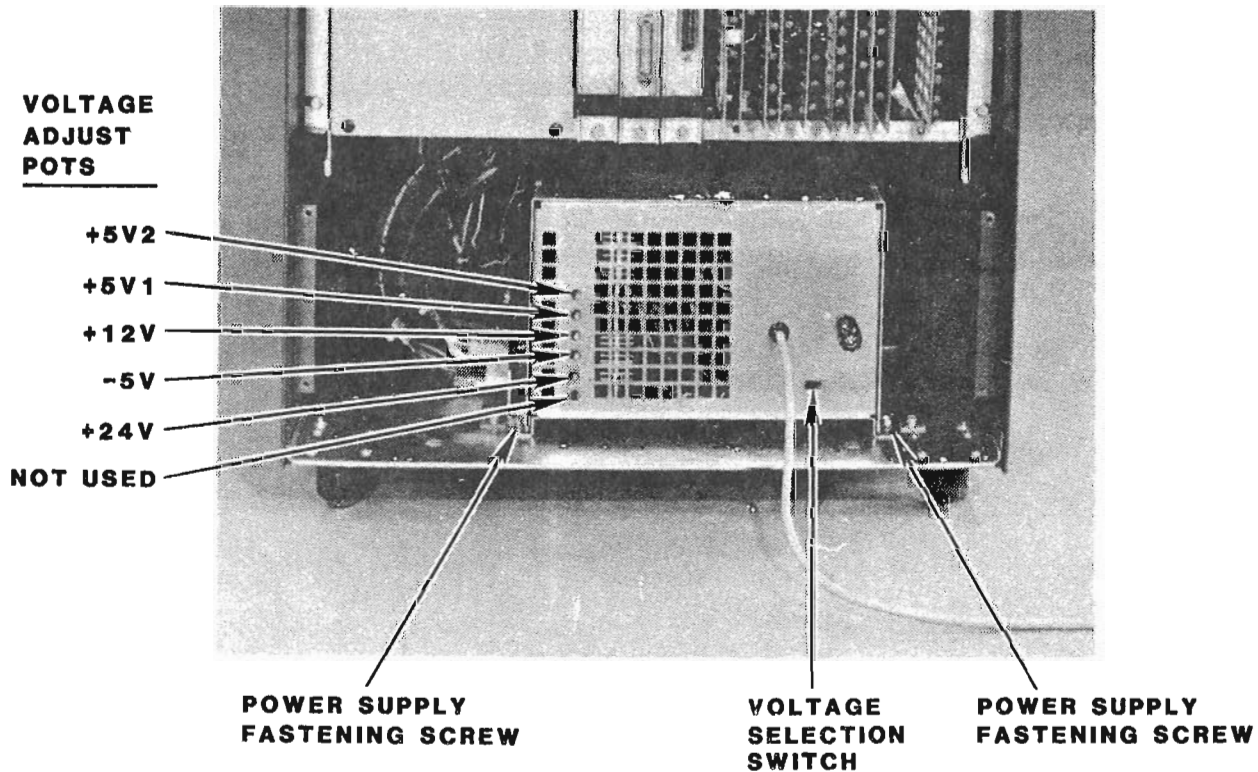

7.8 INSTALLATION OF QUANTUM DISK DRIVE

The Quantum is supplied with a spindle motor lock clip and an actuator lock. THESE MUST BE REMOVED BEFORE THE SYSTEM IS POWERED UP.

Pictured below is the bottom view of the motor spindle lock and actuator lock.

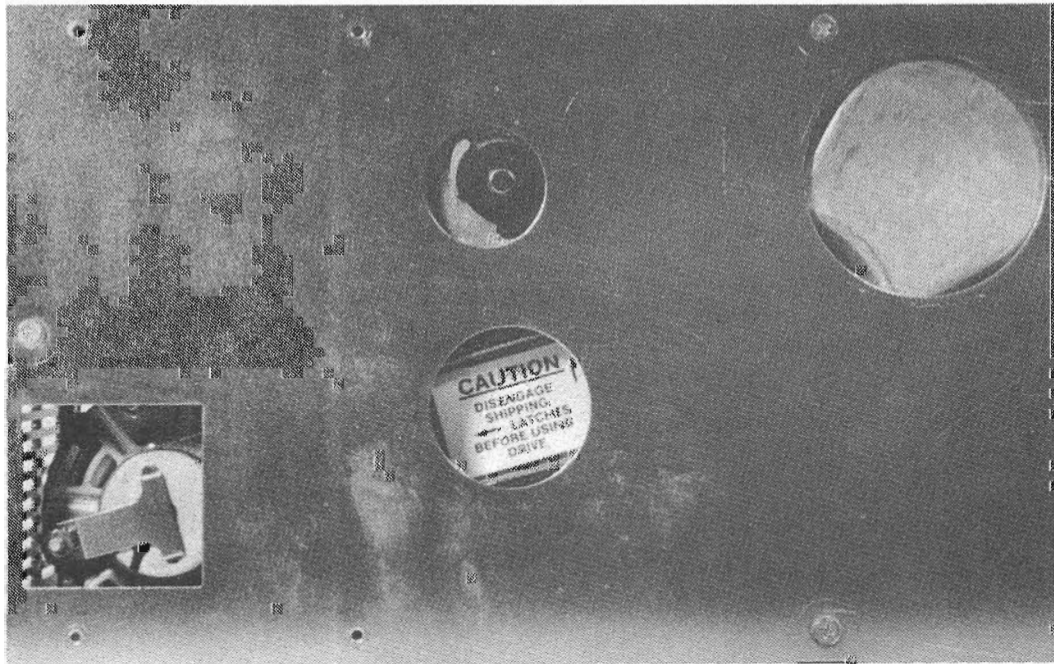

7.9 Spindle Lock Clip Quantum Fixed Disk Drives

1. Stand drive on edge to unlock drive motor.
CAUTION: Do Not set drive on its printed circuit board.
2. Loosen 11/32 inch hex nut.
3. Rotate locking clip away from the pulley. Do not rotate the pulley
4. Retighten the 11/32 inch hex nut.

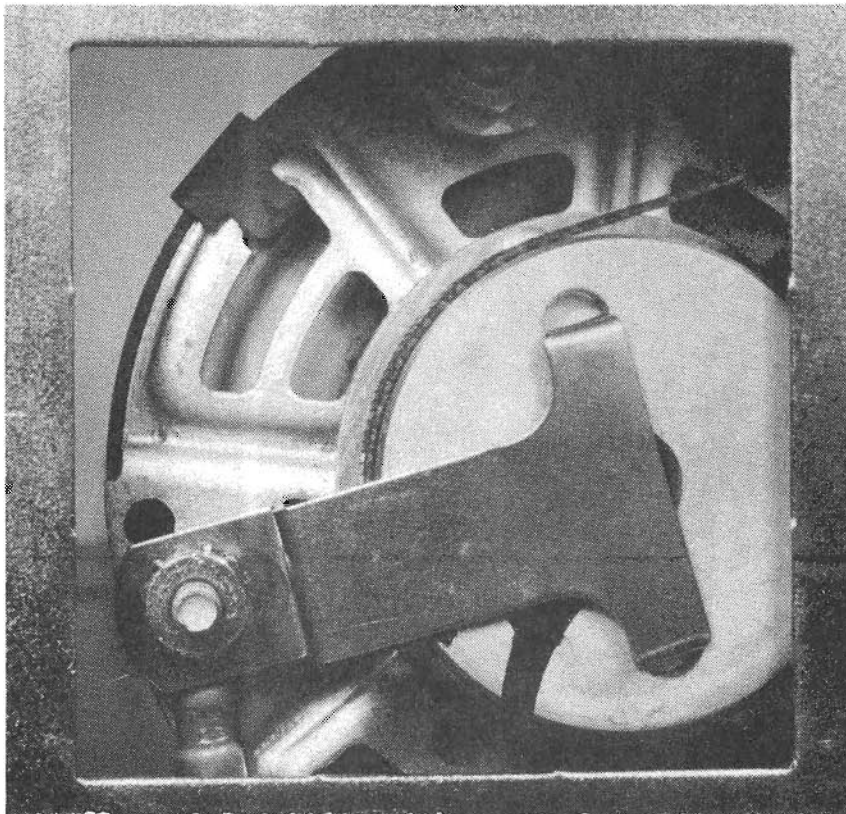

7.10 Actuator Lock

1. The actuator lock is located on the bottom of the drive.
2. Unlock actuator by rotating the actuator lock CCW as far as it will go (approx. 1/2 turn) DO NOT FORCE.

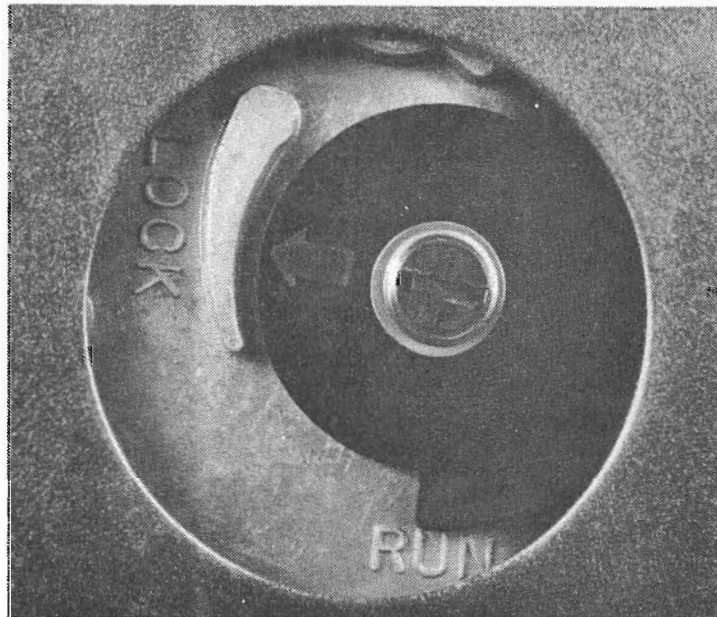

7.11 Jumper Options

Upon installation check each Quantum PC Board for proper jumper configuration (see page 7-12 for PCA jumper locations).

<u>Designation:</u>	<u>Description:</u>	<u>Operating Position</u>
-5/-15	The drive requires -5V DC (-5 V position) but will regulate higher negative voltages from -7 to -16 (when in the -15 position)	-5
DS-1,2,3,& 4	Four drive select jumpers, allows logical drive assignment	DS-1

The following are jumpers to be installed when troubleshooting the drive. This will normally NOT be done in the field, since the drive will be replaced once the problem is isolated to that drive, and is only included for information purposes.

<u>Designation</u>	<u>Description</u>	<u>Operating Position</u>
A	Causes drive to be selected constantly.	Out
C	When jumpered, allows J1 pin 6 "REZERO" to be used to cause the drive to recalibrate.	Out
E3	When jumpered, disables the fine servo for maintenance purposes..	Out
E4	When jumpered, causes the microprocessor to perform a seek diagnostic routine.	Out

7.12 Control Line Termination

If the drive is the last drive at the end of the control signal cable, as is the case with the 2200 LVP, a 220/330 terminator pack must be installed at PCA location J6. The Quantum P/N for the terminator pack is 13-12302.

7.13 Packing for Shipment

In the event that the drive must be returned for repair, just reverse the procedure for installing the "Actuator Lock" and the "Spindle Motor Locking Clip", and carefully place the drive in a padded shipping container.

7.14 The switch settings on the #210-8696 Microprocessor/ Memory board when using the SHUGART or QUANTUM Drive are as follows:

2	4	8	Switch numbers
on	on	on	No fixed
on	off	on	Shugart 4 Meg fixed
off	on	on	Shugart 8 Meg fixed
on	on	off	Quantum 16 Meg fixed
off	on	off	Quantum 32 Meg (2 platters)

NOTE:

- * Switch 6 is for the floppy. If on, there is no floppy on the system, if off then there is a floppy on the system.
- * Switch 3 is used for power-up diagnostics, it should be in the off position.
- * All other switches should be ~~off~~. ON
- * All PROM'S on the board should be Rev. R-8

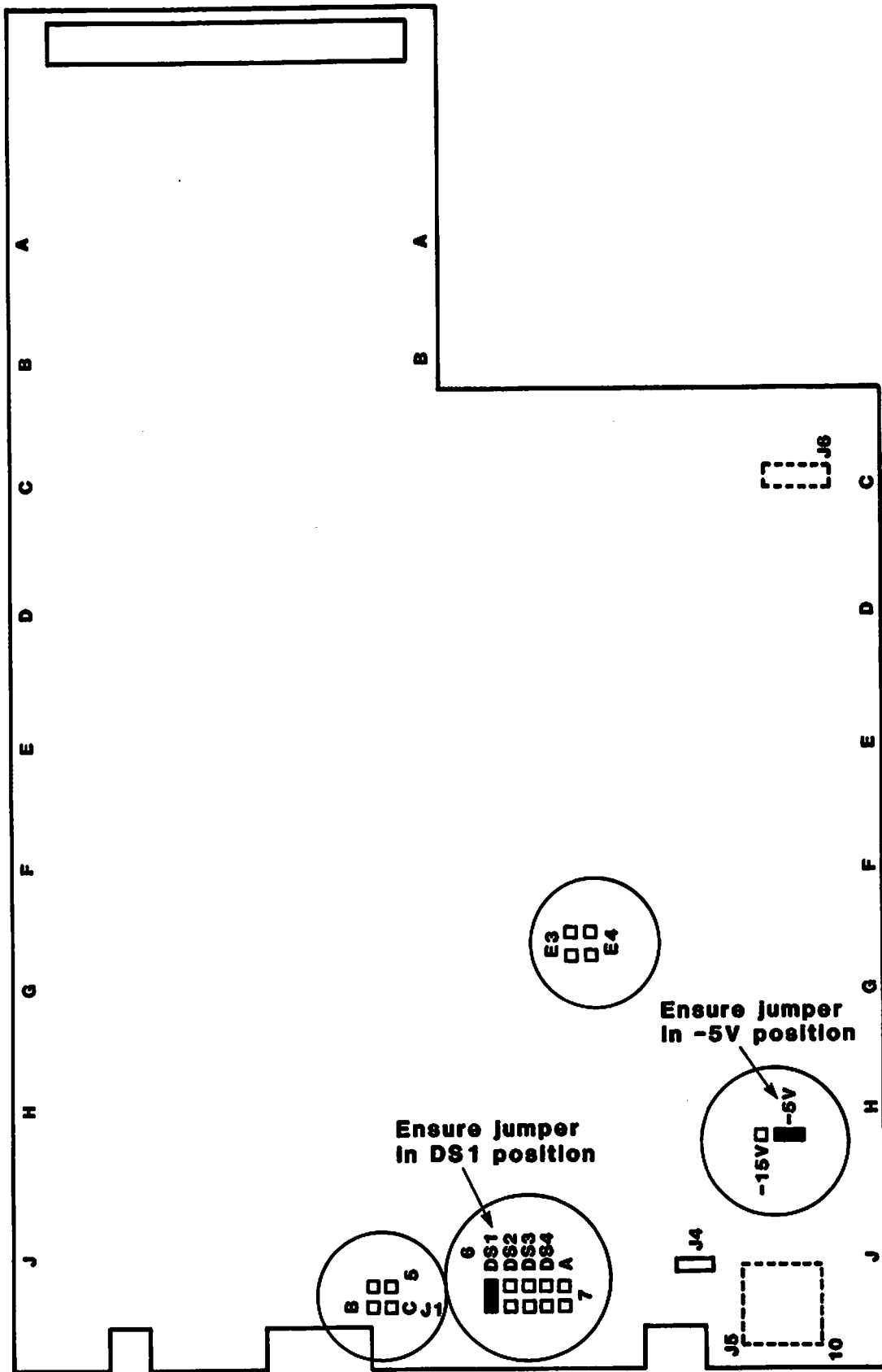

QUANTUM PCB Jumper Locations

EXERCISE 2

Please complete the following exercise to ensure that you understand the material presented thus far.

1. A different sequence for adjusting the MVP power supply is required with the option "C".
true / false

2. The Quantum disk drive can be serviced in the field.
true / false

3. For field installation of option "C" on either the MVP or LVP, the old motherboard can be used if necessary.
true / false

4. Preventive maintenance is the same on the option "C" as the standard version of the MVP/LVP.
true / false

NOTE: Answers may be found on page EX 2-2

ANSWERS to EXERCISE 2

1. true
2. false
3. false
4. true

APPENDIX "A"

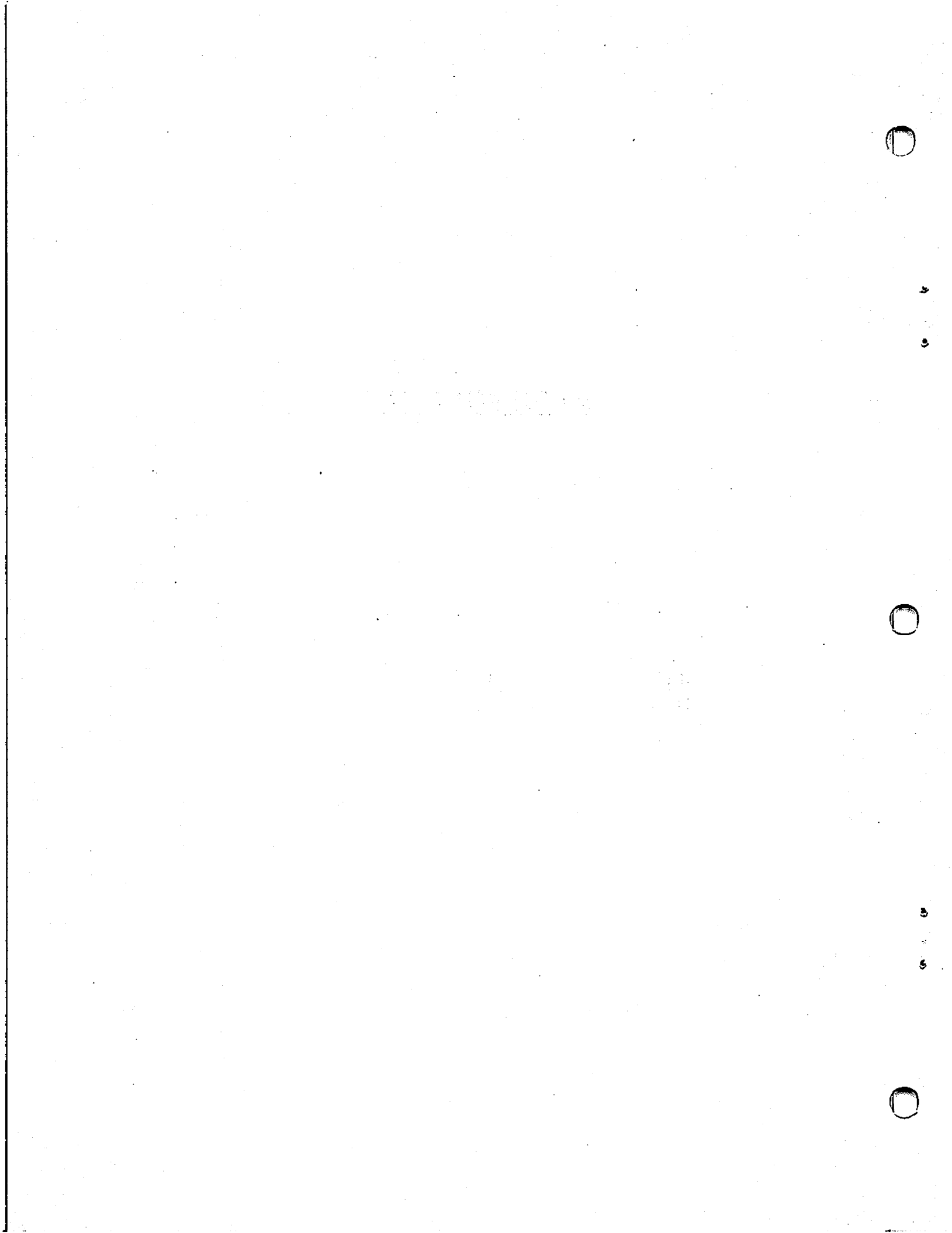

Revision Log

<u>Date</u>	<u>Revision Number</u>	<u>Change</u>
Feb 8, 1982	1.0	Added switch settings for Quantum Drive on #210-8696 board Added additional quiz
Feb 18, 1982	1.1	Added additional Quantum drive information on page 2-8
Mar 2, 1982	1.2	Replaced page 2-4 to clarify signal IC15 and <u>ROMS</u> .

Section 10

1. The first part of the document discusses the importance of maintaining accurate records of all transactions. It emphasizes that every entry should be supported by a valid receipt or invoice. This ensures that the financial statements are reliable and can be audited without any discrepancies.

2. The second part of the document outlines the procedures for handling cash payments. It states that all cash receipts should be deposited into the company's bank account immediately. Any cash payments should be made through the company's bank account to maintain a clear audit trail.

3. The third part of the document describes the process for recording sales and purchases. It requires that all sales be recorded at the time of the transaction, and all purchases be recorded when the goods are received. This helps in maintaining an up-to-date inventory and understanding the company's financial position at any given time.



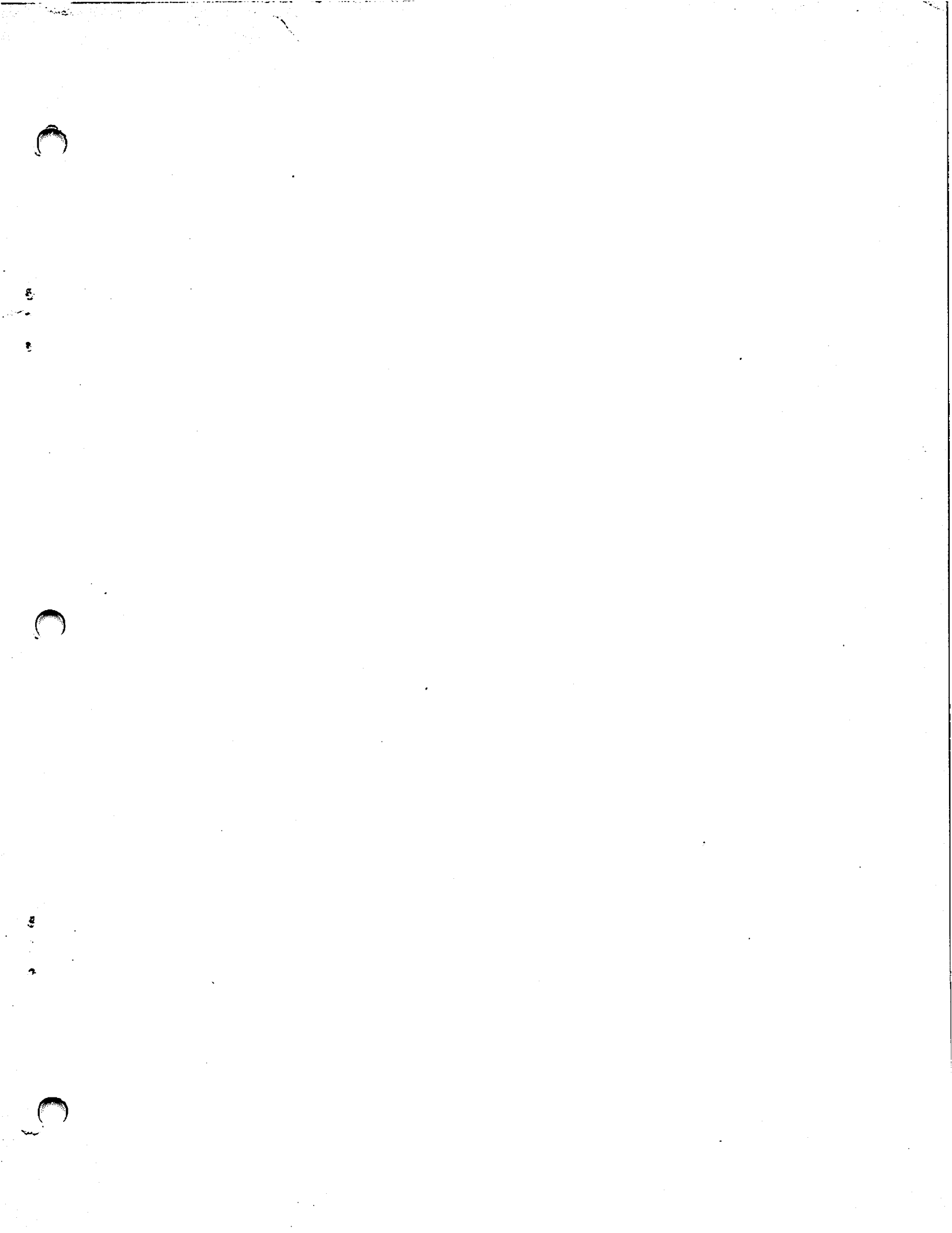

WANG

ONE INDUSTRIAL AVENUE
LOWELL, MASSACHUSETTS 01851
TEL. (617) 459-5000
TWX 710-343-6769, TELEX 94-7421

PRINTED IN U.S.A.