

CUSTOMER SITE PLANNING GUIDE

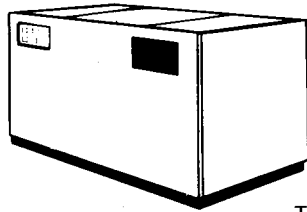

TYPESETTER

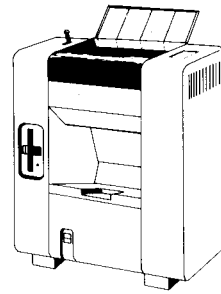

WANGWRITER
CONSOLE

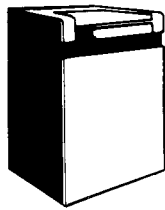

DISK DRIVES

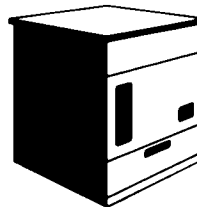

OIS 140-145
MASTER



WORK
STATION

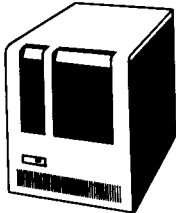

2200LVP

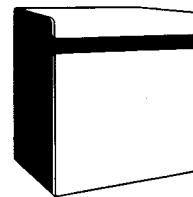

VS CPU

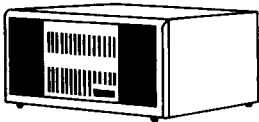

2200 SVP

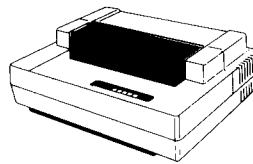

MATRIX PRINTERS

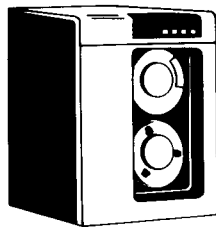

TAPE DRIVES

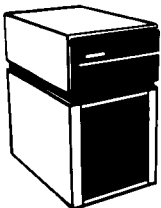

DISK DRIVES

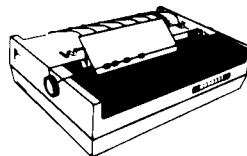

DAISY PRINTERS

WANG

CUSTOMER SITE PLANNING GUIDE

5th Edition — January, 1983
Copyright © Wang Laboratories, Inc., 1980
700-5978D



Disclaimer of Warranties and Limitation of Liabilities

The staff of Wang Laboratories, Inc., has taken due care in preparing this manual; however, nothing contained herein modifies or alters in any way the standard terms and conditions of the Wang purchase agreement, lease agreement, or rental agreement by which this equipment was acquired, nor increases in any way Wang's liability to the customer. In no event shall Wang Laboratories, Inc., or its subsidiaries be liable for incidental or consequential damages in connection with or arising from the use of this manual or any programs contained herein.



PREFACE

This publication is for anyone preparing a site for the installation of a Wang Word Processing System, a Wang Office Information System, or a Wang Data Processing System. It contains physical, electrical, and environmental specifications for the system components and suggests some ways of preparing the site before the system actually arrives.

Chapter 1 presents an overview of the task of planning an optimum environment for the system. It contains a schedule of the steps that must be completed before the system arrives at the site.

Chapter 2 presents suggestions for laying out and preparing the physical area for the system, and for the storage of supplies and data backup.

Chapter 3 contains electrical power requirements and cabling information for all Wang equipment. This chapter also discusses system grounding and electrical noise considerations.

Chapter 4 discusses the physical environment necessary for the proper functioning of the system components, for the storage of magnetic data media, and for the people involved in the system's operation.

Appendix A contains descriptive information for all Wang equipment. Also included are tables listing physical size, recommended floor space, weight, and heat dissipation for each piece of equipment.

Appendix B contains a list of the cables available from Wang. If the supplied cables are not sufficient, refer to this list.

Appendix C contains a set of grids with the recommended floor space for system components. These may be used for arranging floor plans of the system equipment.

Appendix D presents electrical information for VS-90 and VS-100 installation.

Appendix E discusses the installation of 7500T equipment.

Other Wang documentation that may be helpful to you is listed in the *Wang Corporate Publications Literature Catalog* (700-5294).

NOTE

For more technical information on systems installation, your Wang customer representative should consult the *Systems Installation Guide for VS, 2200, WP/OIS Systems* (729-0907).

CONTENTS

CHAPTER 1	OVERVIEW	
1.1	Introduction	1-1
1.2	Installation Schedule	1-2
CHAPTER 2	SITE SELECTION AND LAYOUT	
2.1	Space Requirements	2-1
2.2	Site Layout	2-2
2.3	Storage of Backup Disks and Supplies	2-3
2.4	Fire Protection Equipment	2-5
2.5	System Preinstallation	2-6
CHAPTER 3	POWER AND CABLING CONSIDERATIONS	
3.1	Electrical Wiring	3-1
3.2	Power and Frequency Tolerance	3-9
3.3	System Grounding	3-9
3.4	Electrical Noise	3-9
3.5	Cabling Considerations	3-10
3.6	Interbuilding Cabling	3-11
CHAPTER 4	ENVIRONMENTAL CONSIDERATIONS	
4.1	Introduction	4-1
4.2	Temperature	4-1
4.3	Humidity	4-2
4.4	Dirt and Dust	4-3
4.5	Static Electricity	4-4
4.6	Lighting and Acoustics	4-5
APPENDICES		
Appendix A	Product Information	A-1
Appendix B	Cables	B-1
Appendix C	Site Layout Grids	C-1
Appendix D	VS-90 and VS-100 Mainframe Electrical Considerations	D-1
Appendix E	Installation Considerations for 7500T Equipment	E-1

FIGURES

Figure 1-1	A Wang Word Processing System Configuration	1-1
Figure 2-1	A Centralized Wang System	2-1
Figure 2-2	Planning Working Space	2-3
Figure 2-3	Diskettes, Disks, and Disk Packs	2-4
Figure 3-1	Representative Power Connectors	3-2
Figure 4-1	Sound-Absorbing Modular Panel	4-6
Figure C-1	Floor Plan Layout Grid	C-3
Figure C-2	Recommended Equipment Floor Space Cutouts	C-5
Figure D-1	Recommended AC Wiring Schematic for the VS-90 and VS-100	D-1

TABLES

Table 3-1	Power Planning Information (2200 products)	3-3
Table 3-2	Power Planning Information (OIS/ALLIANCE/WP products)	3-4
Table 3-3	Power Planning Information (VS products)	3-6
Table 3-4	Power Planning Information (7500T products)	3-8
Table 4-1	Environmental Information	4-3
Table A-1	Site Planning Information (2200 products)	A-2
Table A-2	Site Planning Information (OIS/ALLIANCE/WP products)	A-3
Table A-3	Site Planning Information (VS products)	A-5
Table A-4	Site Planning Information (7500T products)	A-7
Table A-5	Site Planning Information (Furniture)	A-8
Table A-6	Workstations/Terminals	A-9
Table A-7	Disk Drives/Magnetic Tape Drives	A-16
Table A-8	Central Processors/Master Processors	A-20
Table A-9	Printers/Plotters/Typesetters	A-25
Table A-10	Miscellaneous Equipment	A-30
Table A-11	Standing Furniture	A-32
Table B-1	Cable Identification (2200 products)	B-1
Table B-2	Cable Identification (WP/OIS products)	B-4
Table B-3	Cable Identification (VS products)	B-5
Table B-4	Coaxial Cables	B-7

CHAPTER 1 OVERVIEW

1.1 INTRODUCTION

The installation of your Wang system requires a planned, coordinated effort involving not only the actual equipment but such related factors as:

- Site location and floor plan
- Environmental requirements
- Electrical requirements
- Cable routing
- Equipment transportation

This guide is designed to assist you in preparing your Wang system site for the most efficient location of equipment and personnel. With the increasing complexity in circuit and system design, now more than ever before site preparation is critical to the overall performance of processing equipment. Location, design, and construction of a site, the power source, the environmental control systems, and even the operators, all contribute to the effective operation of a system. From the simplest of peripheral devices to the most complex Central Processing Unit (CPU), without care and planning in the selection or building of a suitable site, a single device or a complete system will not perform up to its maximum potential.

Wang sales representatives, analysts, and customer engineers are available for consultation and assistance when installing your system, with little or no interruption of the daily business routine. A Wang Customer Engineer (CE) will perform the actual installation of your system components.



Figure 1-1. A Wang Word Processing System Configuration

1.2 INSTALLATION SCHEDULE

Check the following schedule to ensure that your system is installed to function optimally. Subsequent chapters provide suggestions and detailed information to ensure meeting the installation schedule.

Ten Weeks Prior to Delivery

1. Prepare a preliminary layout of the proposed installation.
2. After the site has been planned, review the equipment order.
3. Submit the cable order at this time if it has not already been submitted.
4. If a telecommunications package is ordered, contact the telephone company or an approved modem vendor to prepare the installation of all telephones, modems, and telephone lines.

Six Weeks Prior to Delivery

1. Complete plans for the equipment room. These plans should be approved by your Wang CE management.
2. Review cable requirements, especially cables routed through conduits, ceilings, floors, or walls.
3. Inspect facilities for the installation of sprinkler systems, environmental control equipment, and fire extinguishers.
4. Have your electrician review the electric service, line noise, wiring, power supply, and power distribution.
5. If building alterations are required, complete these modifications before system delivery. Include space for supplies and Wang customer documentation.
6. Check the loading capacity of elevators and the size limits of halls and doorways to be used to transport the system to the desired site.

Two Weeks Prior to Delivery

1. Have all planned modifications for wiring, air conditioning, and communication facilities completed and tested one week before machine delivery.
2. Building alterations should be completed at this time.

CHAPTER 2 SITE SELECTION AND LAYOUT

2.1 SPACE REQUIREMENTS

A major area of concern while planning a site is selecting the location of the Wang CPU or master processor, disk drives, disks, printers, and workstations. The complete system may be centralized in a single room, or workstations may extend the system throughout the building, across the town, or across the country. The site may be open and readily accessible, or it may be securely restricted.

Usually, the CPU, disk drives, and printers are located in one area. The workstations are placed wherever needed in open centralized areas, in several small clusters near the departments they serve, in individual offices, or many floors away from the CPU.

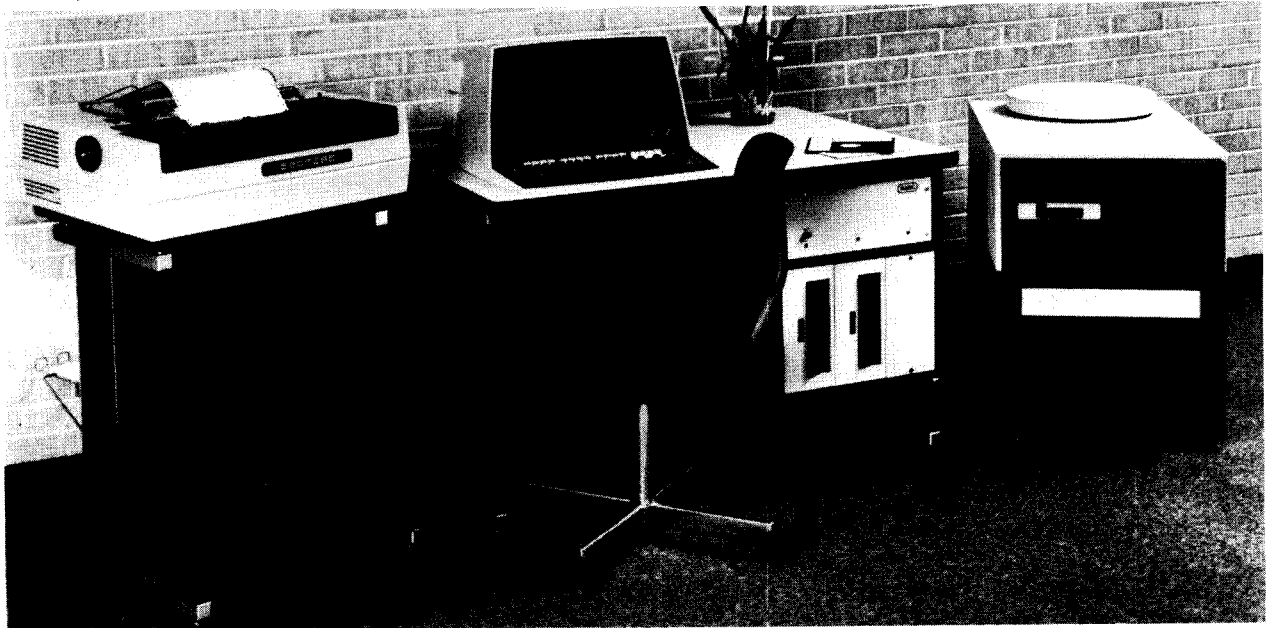

Figure 2-1. A Centralized Wang System

As soon as the order for the system is placed, prepare a preliminary floor plan of the data processing areas and lay out the placement of the CPU, printers, workstations, and any other peripherals on the grids provided in Appendix C. As you plan the area, be sure to include the following.

- Space for the CPU, workstations, disks, printers, desks, files, and miscellaneous equipment

The workstations can be conveniently located almost anywhere they are needed; they may be located up to 2000 feet from the CPU or attached remotely to be serviced by telecommunications. It may be advisable, however, to situate the offices of programmers, operators, and supervisors, and other personnel requiring direct physical access to the central system near the central site.

-
-
- Space for storing supplies and documentation

Systems manuals and related documents should be readily accessible. Disks should be stored away from any magnetic or radiation fields. Disks and paper should optimally have an environment with the same humidity and temperature as the data processing room.

- Space requirements related to servicing the equipment

The recommended floor space for each piece of equipment is shown in Tables A-1 through A-5 of Appendix A.

- Space for people to work efficiently

The system layout must be planned so that people can work efficiently with the system. Space must be allowed for aisles, work areas, and storage. Equipment such as printers should be close enough to terminals so that system-operator traffic is minimized.

- Space for future expansion

When selecting a site, space requirements for expansion should be taken into consideration. Although the present system will probably meet immediate processing needs, the likelihood of future expansion should not be overlooked. As people become comfortable with the system, ideas for new and expanded applications will probably arise. Potential problems of future crowding, traffic flow, inaccessibility, and poorly planned work areas can be avoided by allowing for expansion from the start.

2.2 SITE LAYOUT

Appendix C contains a site layout work-kit consisting of a grid (English scale) and a sheet of scaled floor space dimensions. To plan your layout, measure your computer site and draw it to scale on the grid. Cut out the recommended floor space dimensions of the equipment pieces that fit your configuration (label pieces accordingly) and position them on the worksheet in various ways until you arrive at the optimal setup. (Note that the lateral service clearance of each piece of equipment is included in the floor space dimensions.) Non-Wang equipment such as desks, filing cabinets, and other furniture should also be mapped onto the worksheet. After a good physical setup has been composed, check that the electrical outlets (receptacles) and line voltages correspond to the required equipment specifications (see Tables 3-1 through 3-4). Ensure that additional outlets are available for noncomputer equipment, and provide extra outlets for future expansion.

Location of equipment and furniture should be based on the operational requirements of the system and the efficiency, comfort, and convenience of the people using the room. Layout of the equipment sites, both central and distributed, as well as storage areas must be planned before furniture and equipment are moved into place and connected for operation. Because the individual pieces of equipment are interconnected by cables of limited length, and because of the need to maintain clearances for access, service, and work space, you may need to consider several tentative layouts before selecting the layout best suited to your operational requirements.



Figure 2-2. Planning Working Space

To protect confidential or sensitive information, access to the central system or workstations should be restricted. Maximum security can be achieved by locating the system, workstations, and disk files behind locked doors. Backup programs and data files should be locked in a separate, and perhaps remote, location. Fireproof storage vaults should be used for optimum protection of data media.

Consult your Wang representative to assist in planning the system layout.

2.3 STORAGE OF BACKUP DISKS AND SUPPLIES

Wang systems require certain supplies. You will need storage space for bulk paper, operations manuals, disk packs, and cleaning supplies. Such equipment as disk packs will require both short-term, easily accessible storage and long-term, backup storage to ensure uninterrupted operation. Space should be reserved for operators and work produced by the system. Provisions for waste and recycling should be made.

The amount of space allocated for the storage of diskettes, disk cartridges, disk packs, and magnetic tape depends on the volume of work to be done and the types of storage media to be used. Diskettes are easily stored on shelves in the work area or at the operators' desks in plastic cases or plastic pockets.



FD-1
8" Floppy Diskette
 177-0063

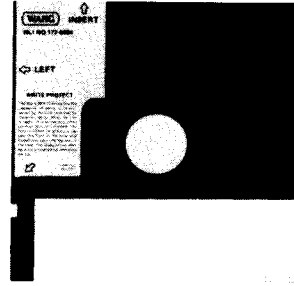

FD-2
5" Minidiskette
 177-0064

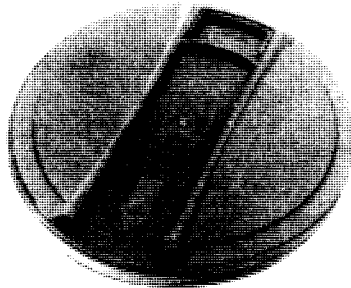

13.4MB Disk Cartridge
 177-0071

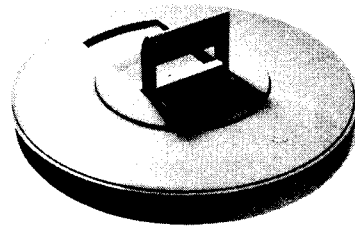

5MB Disk Cartridge
 177-0062

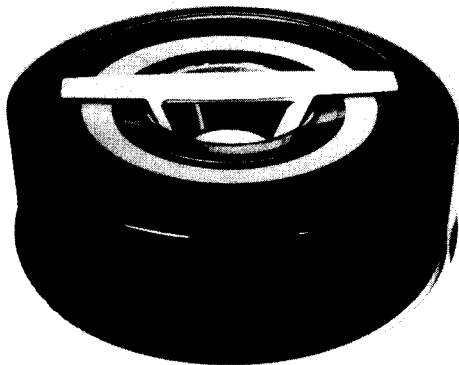

288MB Disk Pack
 177-0706

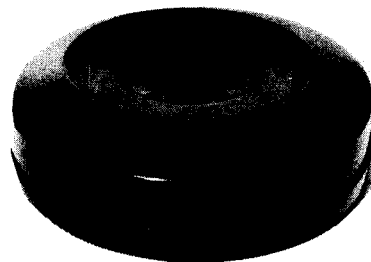

75MB Disk Pack
 725-0705

Figure 2-3. Diskettes, Disks, and Disk Packs

A disk cartridge contains one disk platter and is enclosed in a plastic case about 2½ in. (6.4 cm) high and 15 in. (38.1 cm) in diameter. A disk pack contains more than one platter and may be up to 12 in. (30.5 cm) high. For short-term storage, the cartridge provides adequate protection. Cartridges may be stacked (up to five high) or stored on their sides in dust-free, fire resistant cabinets. For long-term storage, it is recommended that the disk cartridges (or disk packs) be repacked in their original cardboard shipping containers to further protect them from dust accumulation.

Ideally, the storage environment for disks should be the same as that of the machine room (refer to Chapter 4). If disks are stored in an environment that differs from that of the disk drive, the cartridge should be moved into the machine room at least two hours *prior* to use.

A high priority in your operating activities should be *file backup*. File backup is maintaining a backup copy of important files on disk.

Disk storage devices are generally very reliable. However, like any other storage media, disk platters are subject to accidental damage or destruction. Losing power during an update, dropping a disk cartridge, and exposing the disk to a magnetic device are just a few of the things that could cause the destruction of data.

As a general rule, it is recommended that important files be backed up with a frequency that matches the processing activity of that file. If a file is updated daily, it should be backed up daily; if a file is updated weekly, it should be backed up weekly.

It is also a good practice to create an extra copy of a backup platter and/or keep more than one generation of these platters. Very often, the backup platter can be ruined by the same problem that destroyed the original platter. Having this extra backup platter provides an additional measure of protection against time-consuming and costly data reconstruction.

2.4 FIRE PROTECTION EQUIPMENT

Review and implement fire prevention measures before installing the system. An insurance agent should be thoroughly familiar with all applicable regulations and can advise you of any insurance premium savings made possible by improved fire prevention measures.

The machine room should be equipped with portable fire extinguishers suitable for quick, efficient use. A nonwetting fire extinguisher for electrical equipment (Class C) is recommended. A preaction sprinkler system is suggested if local building codes, ordinances, or insurance regulations require automatic water sprinklers, and if this type of sprinkler complies with local regulations. Commercial fire protection systems are available that have been designed specifically for the computer environment. There are systems on the market that provide a nonwater, nontoxic, extinguishing capability. Your local fire department can recommend the best type of extinguishers for your needs and can advise you of the best locations for their placement.

Fire protection around the outside of the data processing room (in adjoining rooms, and the floor space above and below) is as important to the safety of the system as fire protection within the room itself. Halone gas systems, fire walls, and magnetic doors are among the many fire protection methods available. Contact your insurance agent for the method best suited to your data processing arrangements.

Combustible materials such as cleaning solvents should be stored in fire resistant containers in accordance with National Fire Protection Association standards. In addition, attention should be given to protecting paper forms, reports, disk cartridges, diskettes, and tapes from destruction in the event of fire. A fire resistant safe or file cabinet may be used for this purpose. It is always good practice to keep a backup copy of important data files in a remotely located, fire-resistant container.

2.5 SYSTEM PREINSTALLATION

It is your responsibility to get the equipment from the loading dock of your building to the system site. You should plan the route the system will travel during the initial physical installation. The following factors must be checked.

- Weights and floor loading

Wang equipment does not exceed standard commercial floor loading of 50 pounds per square foot. However, the floor must also be strong enough to support any lifting equipment used to assist with installation.

- The size of hallways and doors through which the system must be moved

If clearances are inadequate, the services of a rigger may be needed.

- Elevator capacities and loading facilities that will be used to move the system to the equipment site

If alterations or additions to existing facilities are needed, be sure to schedule their completion before system delivery.

All accessory equipment such as tables, stands for the workstations, and modems should be ordered at the time that the system is ordered. Modems should be installed and tested prior to the delivery of your Wang system. Electrical requirements, including service outlets, should be checked and adjusted, if necessary, before the system arrives (refer to Chapter 3).

If telecommunications is part of the system, all telephones and telephone data lines should be ready prior to installation of the system. Wang computer system telecommunications is RS232/CCITT-V.24 compatible. Generally, scheduling for Direct Access Arrangement installation in the USA must be made six to eight weeks in advance, depending on your system site. Contact your local telephone company business office.

Upon receipt of the system, be sure to notify the Wang service office. The system will be unpacked, inspected, and installed by a Wang Customer Engineer.

NOTE

Unpacking and installation by the customer may void the system warranty. The customer may install only those system/units specifically defined by Wang as being customer installable.

CHAPTER 3 POWER AND CABLING CONSIDERATIONS

3.1 ELECTRICAL WIRING

All system power requirements must be discussed with a qualified electrical contractor *before* system installation to ensure that all wiring and electrical hookups conform to local building codes and ordinances.

The system and accessories must be powered from a single main source that is stable and noise free to ensure uninterrupted operation. Power lines to the system should originate from the main AC power distribution panel and must be run in a metal conduit. To prevent static interference, under no circumstances should power lines for other equipment be installed in the same conduit with the Wang equipment power lines.

Most Wang equipment is wired for 115 V or 230 V power, both single-phase 2 wires plus ground. However the VS 90, VS-100 and certain disk drives (2265V-2 and 6565) operate from:

- VS-90, VS-100
208/230 V, 60 Hz, split phase power-2 of 3 phases, 3 wires plus earth ground.
- Model 2265V-2 and 6565 Disk Drives
208/230 V, 60 Hz, 2 phase, 2 wires plus earth ground.

CPU cabinets for 120 V/60 Hz single-phase systems are fitted with three-conductor power cables. Matching 20 ampere receptacles (NEMA 5-15IG or equivalent) are required to supply main power to these cables. Power requirements and the type of receptacles required for the systems and accessories are summarized in Tables 3-1 through 3-4. The plug configurations are shown in Figure 3-1.

It is recommended that CPUs and disk drives be connected to their own separate (dedicated) power lines. Refer to Tables 3-1 through 3-4 to determine whether any components of your system require dedicated lines.

Branch circuits should be protected by circuit breakers suitable for motor load application. The circuits should contain wiring capable of handling the same size load. The circuit breakers should be placed in an unobstructed and well-lit area within the central processing room. As a safety precaution, a means for disconnecting power to all equipment in the central processing room should be readily accessible to the system operator.

NOTE

The dedicated receptacles used to supply power to your system must be checked by a qualified electrician to confirm that they provide the proper line voltage and frequency for which the system and accessories are configured, within the limits specified in Tables 3-1 through 3-4.

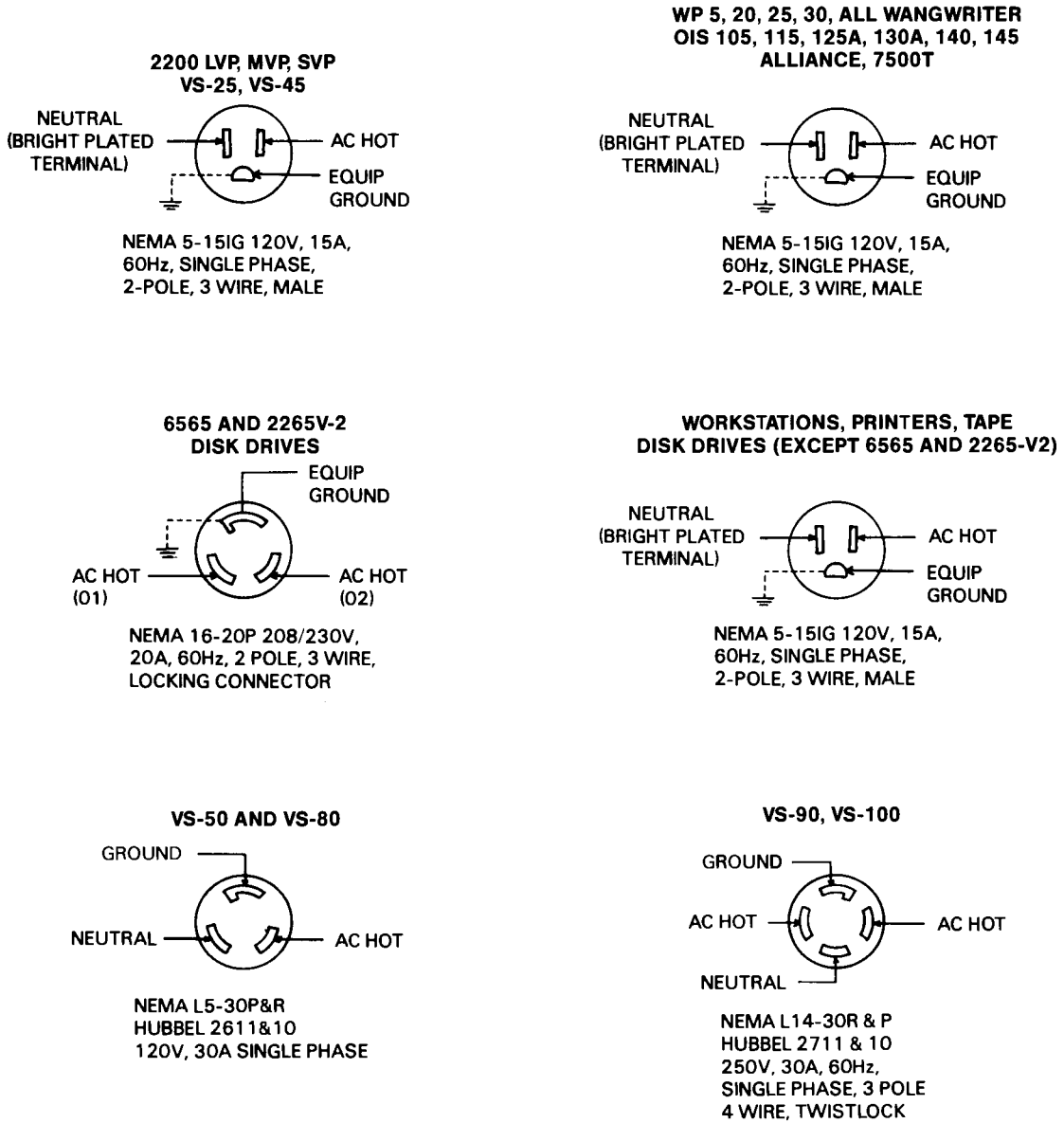

Figure 3-1. Representative Power Connectors

Table 3-1. Power Planning Information (2200 products)

Product	Maximum AC Power (watts)	Operating Voltage*	Power Cable Length ft(m)	Data Cable Length ft(m)	NEMA Power Receptacle
LVP**	317	115 VAC/60 Hz, 230 VAC/50 Hz	10.0(3.0)	—	5-15IG
MVP**	230	115 VAC/60 Hz, 230 VAC/50 Hz	8.0(2.4)	—	5-15IG
SVP**	307	115 VAC/60 Hz, 230 VAC/50 Hz	10.0(3.0)	—	5-15IG
2209A	475	115 VAC/60 Hz, 230 VAC/50 Hz	8.0(2.4)	12.0(3.6)	5-15IG
2211M	25	115 VAC/60 Hz, 230 VAC/50 Hz	6.0(1.8)	12.0(3.6)	5-15IG
2231W-3	150	115 VAC/60 Hz, 230 VAC/50 Hz	6.0(1.8)	12.0(3.6)	5-15IG
2231W-6	150	115 VAC/60 Hz, 230 VAC/50 Hz	6.0(1.8)	12.0(3.6)	5-15IG
2233	92	115 VAC/60 Hz, 230 VAC/50 Hz	6.0(1.8)	12.0(3.6)	5-15IG
2235	126	115 VAC/60 Hz, 230 VAC/50 Hz	6.0(1.8)	12.0(3.6)	5-15IG
2236DE	50	115 VAC/60 Hz, 230 VAC/50 Hz	8.0(2.4)	***	5-15IG
2236DW	50	115 VAC/60 Hz, 230 VAC/50 Hz	8.0(2.4)	***	5-15IG
2245	92	115 VAC/60 Hz, 230 VAC/50 Hz	6.0(1.8)	12.0(3.6)	5-15IG
2260C**+	325	115 VAC/60 Hz, 230 VAC/50 Hz	8.0(2.4)	10.0(3.0)	5-15IG
2270A-1	210	115 VAC/60 Hz, 230 VAC/50 Hz	8.0(2.4)	12.0(3.6)	5-15IG
2270A-2	210	115 VAC/60 Hz, 230 VAC/50 Hz	8.0(2.4)	12.0(3.6)	5-15IG
2270A-3	210	115 VAC/60 Hz, 230 VAC/50 Hz	8.0(2.4)	12.0(3.6)	5-15IG
2273-1	350	115 VAC/60 Hz, 230 VAC/50 Hz	6.0(1.8)	12.0(3.6)	5-15IG
2273-2	350	115 VAC/60 Hz, 230 VAC/50 Hz	6.0(1.8)	12.0(3.6)	5-15IG
2280-1++	950	115 VAC/60 Hz, 230 VAC/50 Hz	8.0(2.4)	15.0(4.5)	5-15IG
2280-2++	950	115 VAC/60 Hz, 230 VAC/50 Hz	8.0(2.4)	15.0(4.5)	5-15IG
2280-3++	950	115 VAC/60 Hz, 230 VAC/50 Hz	8.0(2.4)	15.0(4.5)	5-15IG
2280N-1++	950	115 VAC/60 Hz, 230 VAC/50 Hz	8.0(2.4)	15.0(4.5)	5-15IG
2280N-2++	950	115 VAC/60 Hz, 230 VAC/50 Hz	8.0(2.4)	15.0(4.5)	5-15IG
2280N-3++	950	115 VAC/60 Hz, 230 VAC/50 Hz	8.0(2.4)	15.0(4.5)	5-15IG
2281W	250	115 VAC/60 Hz, 230 VAC/50 Hz	6.0(1.8)	12.0(3.6)	5-15IG
2281WC	250	115 VAC/60 Hz, 230 VAC/50 Hz	6.0(1.8)	12.0(3.6)	5-15IG
2282	65	115 VAC/60 Hz, 230 VAC/50 Hz	8.0(2.4)	12.0(3.6)	5-15IG
2286DE,DW	50	115 VAC/60 Hz, 230 VAC/50 Hz	8.0(2.4)	***	5-15IG
2336DW	50	115 VAC/60 Hz, 230 VAC/50 Hz	8.0(2.4)	***	5-15IG
DW/22-20	125	125 VAC/60 Hz, 230 VAC/50 Hz	12.0(3.6)	25.0(7.5)	5-15IG

* All voltages are ± 10%; Hertz is ± 1 cycle.

** Requires dedicated circuit.

*** Up to 2000 ft. (610 m)

+ Starting load is 800 watts.

++ Starting load is 1900 watts; standing load is 250 watts.

Table 3-2. Power Planning Information (OIS/ALLIANCE/WP products)

Product	Maximum AC Power (watts)	Operating Voltage*	Power Cable Length ft(m)	Data Cable Length ft(m)	NEMA Power Receptacle
AWS-1	400	115 VAC/60 Hz, 230 VAC/50 Hz	6.0(1.8)	25.0(7.5)	5-15IG
AWS-4	400	115 VAC/60 Hz, 230 VAC/50 Hz	6.0(1.8)	25.0(7.5)	5-15IG
OIS 105 (6505)**	460	115 VAC/60 Hz, 230 VAC/50 Hz	9.5(2.8)	—	5-15IG
OIS 115 (6515)**	460	115 VAC/60 Hz, 230 VAC/50 Hz	9.5(2.8)	—	5-15IG
OIS 130A (6530A)**	310	115 VAC/60 Hz, 230 VAC/50 Hz	9.5(2.8)	—	5-15IG
OIS 130B (6530B)	310	115 VAC/60 Hz, 230 VAC/50 Hz	9.5(2.8)	—	5-15IG
OIS 130C (6530C)	310	115 VAC/60 Hz, 230 VAC/50 Hz	9.5(2.8)	—	5-15IG
OIS 130D (6530D)	310	115 VAC/60 Hz, 230 VAC/50 Hz	9.5(2.8)	—	5-15IG
OIS 130E (6530E)	310	115 VAC/60 Hz, 230 VAC/50 Hz	9.5(2.8)	—	5-15IG
OIS 140 (6540)**	460	115 VAC/60 Hz, 230 VAC/50 Hz	6.0(1.8)	—	5-15IG
OIS 145 (6545)**	460	115 VAC/60 Hz, 230 VAC/50 Hz	6.0(1.8)	—	5-15IG
Wangwriter(5503,5504)	300	115 VAC/60 Hz, 230 VAC/50 Hz	8.0(2.4)	10.0(3.0)	5-15IG
WP 5 (5505-3)**	250	115 VAC/60 Hz, 230 VAC/50 Hz	8.0(2.4)	—	5-15IG
WP 20 (5520)**	250	115 VAC/60 Hz, 230 VAC/50 Hz	6.0(1.8)	—	5-15IG
WP 25 (5525-3)**	150	115 VAC/60 Hz, 230 VAC/50 Hz	6.0(1.8)	—	5-15IG
WP 30 (5530)**	250	115 VAC/60 Hz, 230 VAC/50 Hz	6.0(1.8)	—	5-15IG
5310,5320	75	115 VAC/60 Hz, 230 VAC/50 Hz	12.0(3.6)	25.0(7.5)	5-15IG
5330,5340	75	115 VAC/60 Hz, 230 VAC/50 Hz	12.0(3.6)	25.0(7.5)	5-15IG
5506-1,2,3	150	115 VAC/60 Hz, 230 VAC/50 Hz	6.0(1.8)	6.0(1.2)	5-15IG
5528	150	115 VAC/60 Hz, 230 VAC/50 Hz	6.0(1.8)	—	5-15IG
5533,-1	92	115 VAC/60 Hz, 230 VAC/50 Hz	6.0(1.8)	—	5-15IG
5535,-1	126	115 VAC/60 Hz, 230 VAC/50 Hz	6.0(1.8)	—	5-15IG
5536-1,2,3,4	177	115 VAC/60 Hz, 230 VAC/50 Hz	6.0(1.8)	—	5-15IG
5541W	300	115 VAC/60 Hz, 230 VAC/50 Hz	6.0(1.8)	12.0(3.6)	5-15IG
5541WC	300	115 VAC/60 Hz, 230 VAC/50 Hz	6.0(1.8)	12.0(3.6)	5-15IG
5548Z**	910	115 VAC/60 Hz, 230 VAC/50 Hz	6.0(1.8)	***	5-15IG
5556C	177	115 VAC/60 Hz, 230 VAC/50 Hz	6.0(1.8)	***	5-15IG
5574	350	115 VAC/60 Hz, 230 VAC/50 Hz	6.0(1.8)	***	5-15IG
5577	400	115 VAC/60 Hz, 230 VAC/50 Hz	6.0(1.8)	***	5-15IG
5581WD,-1	500	115 VAC/60 Hz, 230 VAC/50 Hz	6.0(1.8)	***	5-15IG
5816,26,36,46 series	125	115 VAC/60 Hz, 230 VAC/50 Hz	6.0(1.8)	***	5-15IG
5917,27,37,47 series	240	115 VAC/60 Hz, 230 VAC/50 Hz	6.0(1.8)	***	5-15IG
5918,28,38,48 series	240	115 VAC/60 Hz, 230 VAC/50 Hz	6.0(1.8)	***	5-15IG
5919,29,39,49 series	240	115 VAC/60 Hz, 230 VAC/50 Hz	6.0(1.8)	***	5-15IG
6340	75	115 VAC/60 Hz, 230 VAC/50 Hz	12.0(3.6)	25.0(7.5)	5-15IG
6509	475	115 VAC/60 Hz, 230 VAC/50 Hz	8.0(2.4)	—	5-15IG
6550-1 (WISE)**	150	115 VAC/60 Hz, 230 VAC/50 Hz	6.0(1.8)	***	5-15IG
6560**+	350	115 VAC/60 Hz, 230 VAC/50 Hz	8.0(2.4)	—	5-15IG
6560A**+	350	115 VAC/60 Hz, 230 VAC/50 Hz	8.0(2.4)	—	5-15IG
6560B**+	350	115 VAC/60 Hz, 230 VAC/50 Hz	8.0(2.4)	—	5-15IG
6560C**+	350	115 VAC/60 Hz, 230 VAC/50 Hz	8.0(2.4)	—	5-15IG
6565**	1200	208/230 VAC/60 Hz	6.0(1.8)	—	****L16-20R
6580-1***+	950	115 VAC/60 Hz, 230 VAC/50 Hz	8.0(2.4)	15.0(4.5)	5-15IG
6580-2***+	950	115 VAC/60 Hz, 230 VAC/50 Hz	8.0(2.4)	15.0(4.5)	5-15IG
6580-3***+	950	115 VAC/60 Hz, 230 VAC/50 Hz	8.0(2.4)	15.0(4.5)	5-15IG
6581W,-1	300	115 VAC/60 Hz, 230 VAC/50 Hz	6.0(1.8)	***	5-15IG
6581WC,-1	300	115 VAC/60 Hz, 230 VAC/50 Hz	6.0(1.8)	***	5-15IG
6750	460	115 VAC/60 Hz, 230 VAC/50 Hz	6.0(1.8)	—	5-15IG

Table 3-2. Power Planning Information (OIS/ALLIANCE/WP products) (continued)

Product	Maximum AC Power (watts)	Operating Voltage*	Power Cable Length ft(m)	Data Cable Length ft(m)	NEMA Power Receptacle
DW/WP-20	125	115 VAC/60 Hz, 230 VAC/50 Hz	12.0(3.6)	25.0(7.5)	5-15IG
DW/5-20	125	115 VAC/60 Hz, 230 VAC/50 Hz	12.0(3.6)	25.0(7.5)	5-15IG
DW/OS-20	125	115 VAC/60 Hz, 230 VAC/50 Hz	12.0(3.6)	25.0(7.5)	5-15IG
LPS-12	1000	115/220 VAC 60Hz, 230/240 VAC 50Hz	12.0(3.6)	***	5-15IG

* All voltages are $\pm 10\%$; Hertz is ± 1 cycle.
 ** Requires dedicated circuit.
 *** Up to 2000 ft. (610 m)
 **** L16-201G also acceptable.

+ Starting load is 800 watts.
 ++ Starting load is 1900 watts; standing load is 250 watts.

Table 3-3. Power Planning Information (VS products)

Product	Maximum AC Power (watts)	Operating Voltage*	Power Cable Length ft(m)	Data Cable Length ft(m)	NEMA Power Receptacle
AWS Diskette Drive (2266S-1, S-2, S-3) (2266C-1, C-3) (2276C-1, C-3)	250	115 VAC/60 Hz, 230 VAC/50 Hz	8.0(2.4)	—	5-15IG
VS 25**	850	115 VAC/60 Hz, 230 VAC/50 Hz	6.0(1.8)	—	5-15IG
VS 45**	850	115 VAC/60 Hz, 230 VAC/50 Hz	6.0(1.8)	—	5-15IG
VS 50**	1380	115 VAC/60 Hz, 230 VAC/50 Hz	9.0(2.7)	—	L5-30R
VS 80**	1380	115 VAC/60 Hz, 230 VAC/50 Hz	9.0(2.7)	—	L5-30R
VS 90***+	1380	208/230 VAC 60 Hz, 230 VAC/50 Hz	9.0(2.7)	—	L14-30R
VS 100***+	2027	208/230 VAC 60 Hz, 230 VAC/50 Hz	9.0(2.7)	—	L14-30R
2209V	475	115 VAC/60 Hz, 230 VAC/50 Hz	8.0(2.4)	12.0(3.6)	5-15IG
2209V-2	475	115 VAC/60 Hz, 230 VAC/50 Hz	8.0(2.4)	12.0(3.6)	5-15IG
2209V-2B	475	115 VAC/60 Hz, 230 VAC/50 Hz	8.0(2.4)	12.0(3.6)	5-15IG
2209V-3	475	115 VAC/60 Hz, 230 VAC/50 Hz	8.0(2.4)	12.0(3.6)	5-15IG
2209V-3B	475	115 VAC/60 Hz, 230 VAC/50 Hz	8.0(2.4)	12.0(3.6)	5-15IG
2209V-B	475	115 VAC/60 Hz, 230 VAC/50 Hz	8.0(2.4)	12.0(3.6)	5-15IG
2219V-1	475	115 VAC/60 Hz, 230 VAC/50 Hz	8.0(2.4)	12.0(3.6)	L5-30R
2219V-1B	475	115 VAC/60 Hz, 230 VAC/50 Hz	8.0(2.4)	12.0(3.6)	L5-30R
2219V-3,-3B	475	115 VAC/60 Hz, 230 VAC/50 Hz	8.0(2.4)	12.0(3.6)	L5-30R
2233R	92	115 VAC/60 Hz, 230 VAC/50 Hz	6.0(1.8)	12.0(3.6)	5-15IG
2235R	126	115 VAC/60 Hz, 230 VAC/50 Hz	6.0(1.8)	12.0(3.6)	5-15IG
2244V	175	115 VAC/60 Hz, 230 VAC/50 Hz	8.0(2.4)	12.0(3.6)	5-15IG
2246C	250	115 VAC/60 Hz, 230 VAC/50 Hz	7.0(2.1)	***	5-15IG
2246R	250	115 VAC/60 Hz, 230 VAC/50 Hz	7.0(2.1)	***	5-15IG
2246S	250	115 VAC/60 Hz, 230 VAC/50 Hz	7.0(2.1)	***	5-15IG
2246S-2	250	115 VAC/60 Hz, 230 VAC/50 Hz	7.0(2.1)	***	5-15IG
2246S-3	250	115 VAC/60 Hz, 230 VAC/50 Hz	7.0(2.1)	***	5-15IG
2247V-4	65	115 VAC/60 Hz, 230 VAC/50 Hz	6.0(1.8)	25.0(7.5)	5-15IG
2256C	250	115 VAC/60 Hz, 230 VAC/50 Hz	7.0(2.1)	***	5-15IG
2265V-1**	943	115 VAC/60 Hz, 230 VAC/50 Hz	6.0(1.8)	—	5-15IG
2265V-2**	1200	208/230 VAC/60 Hz, 230VAC/50 Hz	6.0(1.8)	—	***L16-20R
2266C-1,C-3	250	115 VAC/60 Hz, 230 VAC/50 Hz	7.0(2.1)	25.0(7.5)	5-15IG
2266S-1,S-2,S-3	250	115 VAC/60 Hz, 230 VAC/50 Hz	7.0(2.1)	25.0(7.5)	5-15IG
2273V-1	350	115 VAC/60 Hz, 230 VAC/50 Hz	6.0(1.8)	12.0(3.6)	5-15IG
2276C-1	250	115 VAC/60 Hz, 230 VAC/50 Hz	7.0(2.1)	25.0(7.5)	5-15IG
2276C-3	250	115 VAC/60 Hz, 230 VAC/50 Hz	7.0(2.1)	25.0(7.5)	5-15IG
2280V-1**+	950	115 VAC/60 Hz, 230 VAC/50 Hz	8.0(2.4)	—	5-15IG
2280V-2**+	950	115 VAC/60 Hz, 230 VAC/50 Hz	8.0(2.4)	—	5-15IG
2280V-3**+	950	115 VAC/60 Hz, 230 VAC/50 Hz	8.0(2.4)	—	5-15IG
2281WCR	300	115 VAC/60 Hz, 230 VAC/50 Hz	6.0(1.8)	***	5-15IG
2281WR	300	115 VAC/60 Hz, 230 VAC/50 Hz	6.0(1.8)	***	5-15IG
2860-1,-2,-3,-4,-5	250	115 VAC/60 Hz, 230 VAC/50 Hz	7.0(2.1)	25.0(7.5)	5-15IG
2866C,C-4,R,S	250	115 VAC/60 Hz, 230 VAC/50 Hz	7.0(2.1)	***	5-15IG

Table 3-3. Power Planning Information (VS products) (continued)

Product	Maximum AC Power (watts)	Operating Voltage*	Power Cable Length ft(m)	Data Cable Length ft(m)	NEMA Power Receptacle
5310,5320	75	115 VAC/60 Hz, 230 VAC/50 Hz	12.0(3.6)	25.0(7.5)	5-15IG
5330,5340	75	115 VAC/60 Hz, 230 VAC/50 Hz	12.0(3.6)	25.0(7.5)	5-15IG
5548Z**	910	115 VAC/60 Hz, 230 VAC/50 Hz	6.0(1.8)	25.0(7.5)	5-15IG
5573	350	115 VAC/60 Hz, 230 VAC/50 Hz	6.0(1.8)	***	5-15IG
5574	350	115 VAC/60 Hz, 230 VAC/50 Hz	6.0(1.8)	***	5-15IG
5575	350	115 VAC/60 Hz, 230 VAC/50 Hz	6.0(1.8)	***	5-15IG
5577	400	115 VAC/60 Hz, 230 VAC/50 Hz	6.0(1.8)	***	5-15IG
6340	75	115 VAC/60 Hz, 230 VAC/50 Hz	12.0(3.7)	25.0(7.5)	5-15IG
6581W	300	115 VAC/60 Hz, 230 VAC/50 Hz	6.0(1.8)	***	5-15IG
6581WC	300	115 VAC/60 Hz, 230 VAC/50 Hz	6.0(1.8)	***	5-15IG
DW/OS-20,DW/R-20	125	115 VAC/60 Hz, 230 VAC/50 Hz	12.0(3.6)	25.0(7.5)	5-15IG
LPS-12	1000	115/220 VAC/60 Hz, 220/240 VAC/50 Hz	12.0(3.6)	***	5-15IG
<p>* All voltages are $\pm 10\%$; Hertz is ± 1 cycle.</p> <p>** Requires dedicated circuit.</p> <p>*** Up to 2000 ft. (610 m)</p> <p>**** L16-201G also acceptable.</p> <p>+ Starting load is 800 watts.</p> <p>++ Starting load is 1900 watts; standing load is 250 watts.</p>					

Table 3-4. Power Planning Information (7500T Products)

Product	Maximum AC Power (watts)	Operating Voltage*	Power Cable Length ft(m)	Data Cable Length ft(m)	NEMA Power Receptacle
7505T**	460	115 VAC/60 Hz, 230 VAC/50 Hz	6.0(1.8)	—	5-15IG
7510T**+	325	115 VAC/60 Hz, 230 VAC/50 Hz	8.0(2.4)	10.0(3.0)	5-15IG
7510TA**+	325	115 VAC/60 Hz, 230 VAC/50 Hz	8.0(2.4)	10.0(3.0)	5-15IG
7511T**+	325	115 VAC/60 Hz, 230 VAC/50 Hz	8.0(2.4)	10.0(3.0)	5-15IG
7511TA**+	325	115 VAC/60 Hz, 230 VAC/50 Hz	8.0(2.4)	10.0(3.0)	5-15IG
7515T**	460	115 VAC/60 Hz, 230 VAC/50 Hz	9.0(2.1)	—	5-15IG
7520T**	250	115 VAC/60 Hz, 230 VAC/50 Hz	7.0(2.1)	—	5-15IG
7525-3T**	250	115 VAC/60 Hz, 230 VAC/50 Hz	7.0(2.1)	—	5-15IG
7526HT	177	115 VAC/60 Hz, 230 VAC/50 Hz	7.0(2.1)	***	5-15IG
7530T**	460	115 VAC/60 Hz, 230 VAC/50 Hz	7.0(2.1)	—	5-15IG
7535T**	460	115 VAC/60 Hz, 230 VAC/50 Hz	7.0(2.1)	—	5-15IG
7536-1T	177	115 VAC/60 Hz, 230 VAC/50 Hz	7.0(2.1)	***	5-15IG
7536-2T	177	115 VAC/60 Hz, 230 VAC/50 Hz	7.0(2.1)	****	5-15IG
7536-4T	177	115 VAC/60 Hz, 230 VAC/50 Hz	7.0(2.1)	****	5-15IG
7540T**	460	115 VAC/60 Hz, 230 VAC/50 Hz	7.0(2.1)	—	5-15IG
7550T**	460	115 VAC/60 Hz, 230 VAC/50 Hz	7.0(2.1)	—	5-15IG
7565-1T**+	943	115 VAC/60 Hz, 230 VAC/50 Hz	6.0(1.8)	15.0(4.5)	5-15IG
7565-1TA**+	943	115 VAC/60 Hz, 230 VAC/50 Hz	6.0(1.8)	15.0(4.5)	5-15IG
7581WT	300	115 VAC/60 Hz, 230 VAC/50 Hz	6.0(1.8)	25.0(7.5)#	5-15IG
7581WCT	300	115 VAC/60 Hz, 230 VAC/50 Hz	6.0(1.8)	25.0(7.5)#	5-15IG
7581W-1T	300	115 VAC/60 Hz, 230 VAC/50 Hz	6.0(1.8)	****	5-15IG
7581C-1T	300	115 VAC/60 Hz, 230 VAC/50 Hz	6.0(1.8)	****	5-15IG
OCR-T, TCB-T	100	115 VAC/60 Hz, 230 VAC/50 Hz	6.0(1.8)	25.0(7.5)	5-15IG
TC-7536-2T	177	115 VAC/60 Hz, 230 VAC/50 Hz	7.0(2.1)	25.0(7.5)	5-15IG
TC-7536-4T	177	115 VAC/60 Hz, 230 VAC/50 Hz	7.0(2.1)	25.0(7.5)	5-15IG

* All voltages are $\pm 10\%$; Hertz is ± 1 cycle.

** Requires dedicated circuit.

*** Up to 500 ft. (153m)

**** Up to 1000 ft (305m)

+ Starting load is 800 watts.

Up to 500 ft (153m) for WP; up to 1000 ft (305m) for OIS.

3.2 POWER AND FREQUENCY TOLERANCE

The steady state voltage must be maintained within $\pm 10\%$ of the normal rated voltage measured at the receptacle when the system is operating. The maximum total harmonic content of the system voltage on the feeder should not exceed 5%. The line frequency variation must not exceed 1 cycle.

Listed below are the specifications for the line filters currently installed in all Wang processor power boxes.

- Handles transients up to 10 joules
- Handles peak currents of 1000 amps for pulse durations of less than 20 microseconds, and frequencies from 1 Hz to 10 MHz
- Handles voltage amplitude of 190 V peak

3.3 SYSTEM GROUNDING

NOTE

A true earth ground must be supplied to the equipment room for *each* circuit feeding power to the system components in order to keep electrical noise under control and preserve system signal integrity. A proper grounding system should include earth ground stakes and/or ground-grid meshes. Water pipes *may not* provide a true earth ground.

Wang-supplied power cords have a green or green-with-yellow-trace grounding conductor for the system ground. The branch circuits supplied by the customer must have an insulated grounding wire conductor equal to the size of the phase conductor. The branch circuit grounding wire must be tied to a common ground point at the distribution panel, and must run to either a service ground or suitable building ground. It is not recommended that the neutral line be tied together with the ground wire to a common ground point at the distribution panel. Earth ground verification tests should be performed by the Wang CE with the assistance of an electrician.

3.4 ELECTRICAL NOISE

A qualified electrician should check the electrical power environment for unusual loads which could induce excessive noise into a branch circuit for the system. Switching heavy inductive loads or operating certain types of equipment near the system may cause problems, even though the source is on a different branch circuit. Some common sources of electrical noise are: air conditioning devices, electrical welders, electrical furnaces, elevators, electrostatic copying machines, and large brush-type motors.

If the electrician suspects such a condition, the site should be investigated thoroughly to determine what corrective measures must be taken. In some cases, it may be advisable to provide a separate power line for the system *direct* from the power supplied to the main building power. In cases of severe electrical noise, it may be necessary to install an isolation transformer and/or a radio frequency filter, a line conditioner, or an uninterruptable power source.

Electrical noise can sometimes be eliminated by repair, replacement, relocation, or electrical filtering of the originating device. A noise filter is included as part of the CPU cabinet to handle normal noise on power lines; at times, however, additional filtering at the local site may be required for extreme cases.

3.5 CABLING CONSIDERATIONS

The components of all Wang systems are supplied with interconnecting signal (data) cables of standard lengths and normally three-wire grounded power cord. In general, peripherals connect directly to the CPU. Some disk drives, however, can connect indirectly by chaining to another drive.

There are three common methods of running cables at an installation site. The first of these methods uses cable troughs (plastic or metal). Plastic troughs are recommended to protect interconnecting cables routed across a large floor area. Cable troughs may be bought from suppliers in varying widths, lengths, and heights to accommodate system cabling.

An alternate method is overhead cable routing. This method eliminates long cable trough runs when the system is installed in the center of a large floor area. The cables may be routed above the ceiling and dropped to the system components. All interconnecting points must be firmly supported. Cables should not be routed near any AC lines or other powered equipment.

A third method utilizes the raised floor. This method allows cables to be run under the floor and out of the traffic area with relative ease, as cables can be run directly from device to device.

NOTE

Small systems with a few peripherals do not require raised flooring, and even larger systems can be installed without raised flooring. Contact your Wang Customer Engineer (CE) if raised flooring is being considered.

If longer cables are required, coaxial cables and some extension cables are available in longer units for most Wang equipment (refer to Appendix B and your *Wang Supplies Catalog* (700-5725)). Coaxial cables may be interconnected only when adapters are used and may extend to a maximum length of 2000 feet (610 meters).

In general, devices are connected directly to the CPU. However, some disk drives may be connected indirectly by chaining to another drive. The system must be situated close enough to a power outlet so the power cable supplied with the CPU processing unit will reach the outlet without an extension cord. Extension power cords may *not* be used to connect any part of the system.

3.6 INTERBUILDING CABLING

Installations requiring cable interconnections from building to building must be routed underground in a conduit to protect the cables both physically and electrically. Metal conduits must incorporate a true earth ground to shield the system cables from any electromagnetic interference (EMI) such as lightning, which can destroy hardware and software elements of a system. Polyethylene water pipe or metal conduit, available in several diameters, affords good protection to the cable and usually makes it possible to replace damaged or failed cable without digging up the area.

NOTE

All cables installed underground require conduit unless otherwise specified. The conduit *must* be isolated from other conduits containing telephone lines, high voltage cable, etc.

The conduit should be buried in sand or fine pulverized dirt that does not contain sharp stones or rubble. Four to six inches of sand may be tamped into the trench for the conduit to lay on and then another six to eleven inches of sand tamped above it. To provide some protection against potential damage to the conduit caused by digging or driving stakes into the area, a creosoted or pressure-treated board may be placed in the trench above the sand layer.

The cable should lay in the conduit with some slack. Check the cable as it is laid to be sure that the cable jacket is not damaged. It is strongly recommended that the cable be buried below the frost line so that damage from the expansion and contraction of the earth can be avoided.

Prior to the system installation date, a qualified electrical contractor should be consulted about cable requirements and the incorporation of a *true earth ground* for interbuilding metal conduits.

CHAPTER 4

ENVIRONMENTAL CONSIDERATIONS

4.1 INTRODUCTION

Temperature, humidity, airborne dust, and electrical noise in prospective installation sites should be evaluated during the planning stage and controlled, if necessary, before your system arrives. In general, if the room the system is to be installed in is comfortable for operators, it will be satisfactory for the system.

Ideally, air conditioning and other environmental control equipment should be located outside the computer site to minimize the noise level and to reduce the possibility of electrical interference. Regardless of the physical location of the control equipment, it must not be connected to the power lines serving the Wang system. If this is absolutely unavoidable, then proper line filtering measures must be taken. If any environmental control equipment is to be installed in the equipment site, be certain to allow adequate space for proper operation and servicing of the unit.

Environmental specifications for the system are also applicable to storage areas for magnetic media. In addition, the humidity and temperature in areas for paper storage should be maintained at the same levels as in the equipment room. Otherwise, differences in humidity may alter the size and weight of the paper when the documents are moved into the work area. This rapid change in atmosphere can result in warpage, the most frequent source of feeding and stacking problems.

4.2 TEMPERATURE

The recommended temperature environment for Wang equipment is shown in Table 4-1. Excessive temperatures will cause equipment failure. Because Wang systems are cooled by the surrounding room air, temperature control is probably the most important environmental factor. The temperature in office buildings and most other installation sites is nearly always controlled within the allowable limits for the system through the usual heating and air conditioning units. Nevertheless, a number of factors should be considered to determine the adequacy of existing temperature controls.

- **Heat dissipated by the Wang system**
All electrical equipment generates heat that is discharged into the room and will raise the temperature unless the air conditioning system can handle the additional heat. Maximum heat dissipation ratings for all components is provided in Tables A-1 through A-4 of Appendix A.
- **Heat dissipated by other equipment**
Heat will also be generated by other equipment in the room (electric typewriters, lights, copying machines, and auxiliary data processing equipment). Approximately 3.4 Btus per watt of electrical power are given off by the equipment. The same number of Btus per hour of air conditioning is also required to keep the environment cooled.

- **Body heat**
Individuals occupying the room will contribute approximately 400 Btus per hour each. This can be an important consideration if a large number of people will occupy the area after the system is installed.
- **Air flow**
Check the volume, temperature, and humidity of fresh air entering the room. Poor ventilation will cause heat to build up near heat-generating equipment.
- **Direct sunlight**
A window or glass-wall area provides virtually no insulation against radiant energy from direct sunlight. Drapes, shades, venetian blinds, or the like should be employed to protect the equipment from direct sunlight, which can raise the equipment temperature excessively without necessarily exceeding the allowable air temperature. If a large glass area cannot be shaded, one of the commercially available glass tinting films to block heat-producing infrared rays is recommended.

Use the following equation to compute the amount of air conditioning Btus required to maintain the operating environment shown in Table 4-1. (This amount does not include the Btus required to maintain this temperature range in an empty room.)

_____	:	Sum of Btu/hr for Wang equipment (see tables in Appendix A)	
+	_____	:	Sum of Btu/hr for other equipment (wattage x 3.4)
+	400 x _____	:	Number of people generally occupying the room
=	_____	:	Btu/hr of air conditioning required (1 ton of air conditioning = 12,500 Btu/hr)

4.3 HUMIDITY

Proper humidity must also be maintained in the equipment room. Relative humidity specifications are shown in Table 4-1. Humidity levels approaching the maximum limit may have an adverse effect on the overall operating efficiency and should be avoided whenever possible. For example, high humidity may cause improper paper feeding or improper flight of the magnetic heads. In extremely humid environments, it is advisable to install a dehumidifying unit in the equipment room.

Most heating and air conditioning systems have a drying effect on the environment. When the humidity is too low, a process known as "oxide shed" occurs, where the magnetic coating on the media wears off excessively on the head, causing I/O errors and loss of data on the media. In addition, static electricity charges, which are usually dissipated without any adverse effects, tend to build up into significant charges when the humidity is low. These charges can destroy data both in memory and on the rapidly rotating magnetic disk, which is particularly susceptible to static buildup. The proper equipment grounding minimizes this effect, but will not eliminate it completely. It may be necessary to install a humidifier to add moisture to the air in very dry areas.

Table 4-1. Environmental Information

Operation Environment*

Ambient Temperature	60°F to 90°F (16°C to 32°C)
Relative Humidity (non-condensing)	20% to 80%
Maximum Wet Bulb Temperature**	75°F (24.5°C)
Operating Temperature Change per Hour	12°F (6.5°C)
Altitude***	10,000ft (3048m)

Storage Environment (Packed)

Ambient Temperature	0°F to 120°F (-17°C to 50°C)
Relative Humidity	10% to 90%

Transit Environment (Packed)

Ambient Temperature	-40°F to 140°F (-40°C to 61°C)
Relative Humidity	5% to 95%

* Recommended environment for VS equipment is 60°F to 80°F and 40% to 60% humidity

*** Tape drives above 4000 ft (1200m) and disk drives (removable disks) above 6500 ft (1960m) require high altitudes options

** Maximum Wet Bulb Temperature Graph

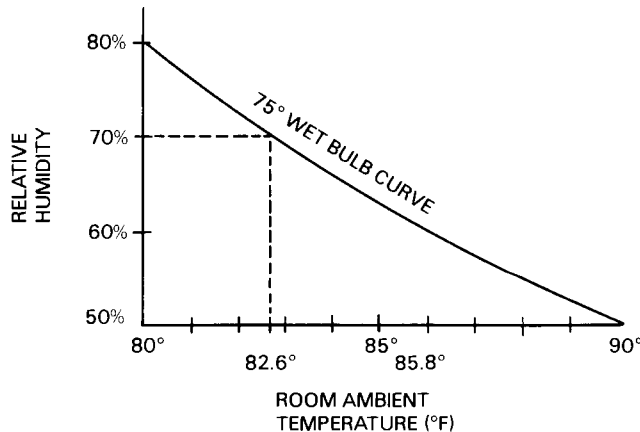

4.4 DIRT AND DUST

The amount of contamination usually found in the air in a normal business environment will not interfere with the operation of the equipment. However, normal precautions should be taken to keep dust, dirt, and other foreign matter away from the machines. The system should not be installed in an area having a high dust content or where there is an exposure to abrasive materials or corrosive gases.

Airborne dust, dirt particles, and smoke can cause equipment operation or maintenance problems. If a film of dust or dirt accumulates on internal surfaces, excessive wear of mechanical parts may occur and electronic components may short-circuit and malfunction. Disk storage units are especially vulnerable to damage from excessive dust.

Usually, dust can be effectively controlled by the normal heating, ventilating, and cooling equipment if units are supplied with adequate filters. These filters should be cleaned or replaced at regular intervals to ensure proper dust filtering and proper temperature. If the usual filters do not control dust effectively, an electrostatic filter should be installed.

After installing the system, floors should be cleaned regularly according to the following recommendations.

- Before cleaning the area, remove diskettes from drives and store them in their original containers in a dry, cool location free from magnetic or radioactive fields.
- Damp-mop tile floors; do not use dry or wet mops.
- Vacuum carpeted floors using nonconducting nozzles.
- Do not buff floors with steel wool.

4.5 STATIC ELECTRICITY

Static electricity is not only an annoyance to the people operating the system, but can cause the equipment to malfunction. Minimizing or eliminating the sources of static is important.

- Ground the equipment cabinets and be sure that the computer is connected to a true earth ground. Water pipes in most new buildings may not provide a suitable earth ground.
- For VS systems use shielded A and B cables or the green/yellow ground straps supplied with disk drives. Do not use both in conjunction (ground loops may occur). Shielded A and B cables are preferred over the green/yellow ground wires.
- Maintain room humidity at about 40%. This is particularly important in the winter months when buildings are heated, since heating dries the air and reduces the humidity significantly.
- Select furniture with anti-static upholstery and metal wheels. Plastic upholstery builds up a charge when clothing moves over it and rubber wheels prevent static bleed-off through the floor covering. The discharge of this build-up to the system framework when the furniture or its occupant come into contact with the equipment can cause the system to malfunction.
- Avoid installing equipment in a carpeted area. If carpeting must be used, it should be designed to minimize static electricity and should be treated with anti-static sprays.

Office furniture is now designed and built in accordance with computer site needs. The recommended furniture with anti-static upholstery and metal wheels is widely available. Wang makes available various tables and covers as system accessories. These tables provide sturdy, expandable, space-saving work and storage areas. These options permit flexibility of arrangement to suit operator needs as well as system configuration. Refer to the *Wang Supplies Catalog* (700-5725).

Carpeting is not recommended at the equipment site because it compounds problems with static, which interferes with system functioning. If the equipment site must be carpeted, select a carpet with good anti-static characteristics, clearly specifying an extremely low residual static electricity level. Avoid wool or nylon carpeting. Anti-static carpeting, containing carbonized filaments to prevent static buildup, is commercially available. In a carpeted environment, plastic or nylon furniture should be avoided.

Carpeting that is not anti-static must be treated with one of the commercially available anti-static fluids. These fluids are usually sprayed onto the carpet and require reapplication at periodic intervals to maintain a static-free environment. It should be noted, however, that spraying may not be sufficient to control static electricity at all times; the problem is particularly severe during winter when buildings are heated and the air is dry.

4.6 LIGHTING AND ACOUSTICS

Wang systems require no special controlled levels of lighting. The screens on workstations are tinted green to ease eyestrain. Office lighting should be evenly diffused and relatively free from glare. Brightness should be uniform and shadows should be minimized.

Glare is any brightness that interferes with vision or causes eyestrain or fatigue. Excessive glare or brightness in the work area forces a person's eyes to continually adjust as they move from light to shadow and back again. Causes of glare include light sources too bright or too large for their particular areas, light sources located too close to an operator, or a dramatic contrast in brightness between a source and its surroundings. To guard the area from excessive glare, shield all lamps within the field of vision and place light sources above the normal line of vision. Light colored ceilings reduce the amount of contrast. Background brightness should be equal to the brightness of the work area, so as to lessen the amount of adjustment the eyes must make.

Expert lighting designers can suggest a system for your needs; have them recommend appropriate fixtures, as well as determine whether fluorescent or incandescent lighting should be used.

Ambient noise, like lighting, has no effect on computer equipment or system operation, but may affect the operator's efficiency. Since some peripheral devices generate noise (especially printers), it is advisable to consider noise output when planning the placement of equipment. For example, printers may be set up alone or with the CPU and disk drives in an isolated area. Cloth-padded modular panels may be used to surround the printers and absorb the sound.

The greatest sound reduction will be achieved by treating the ceiling. The best results can be expected from a dropped, porous ceiling. If overhead ducts exist, noise may be transmitted from room to room unless proper precautions are taken. For large rooms, the floor is the next most effective area on which to apply absorbent material. If it is necessary to use carpeting, ensure that it is of an anti-static variety, or treated regularly with an anti-static spray. Sound baffles can be applied to the walls to help reduce reflective and transmitted sound.



Figure 4-1. Sound-Absorbing Modular Panel

APPENDIX A PRODUCT INFORMATION

This appendix contains site planning information for all Wang equipment including physical size, recommended floor space, weight, and heat dissipation. It should be used in conjunction with the grids in Appendix C when planning a site layout.

NOTE

In general all equipment should be free from overhead obstructions. Recommended overhead service clearances are as follows.

2200 CPUs – 20 in. (51 cm)

OIS/ALLIANCE/7500T/WP MASTERS – 20 in.
(51 cm)

VS 25/45/50/80/90 – 48 in. (122 cm)

VS-100 – 78 in. (196 cm)

Disk Drives – 48 in. (122 cm)

Tape Drives – 48 in. (122 cm)

Printers (cabinet type) – 48 in. (122 cm)

Terminals/Workstations – 18 in. (46 cm)

Table A-1. Site Planning Information (2200 Products)

Product	Height in. (cm)	Width in. (cm)	Depth in. (cm)	Recommended Floor Space Width x Depth ft (m)	Net Weight lb (kg)	Maximum Heat Dissipation Btu/hr (kg-cal/hr)
LVP	27.0 (68.6)	20.4 (51.8)	30.0 (76.2)	3 x 6 (.9 x 1.8)	166 (75.5)	1082 (273)
MVP	14.5 (36.8)	25.0 (63.5)	10.0 (25.4)	2 x 3 (.6 x .9)	47 (21.3)	785 (198)
SVP	12.0 (30.5)	21.0 (53.5)	26.0 (66.0)	3 x 5 (.9 x 1.5)*	75 (34.1)	785 (198)
2209A	34.5 (87.6)	24.0 (61.0)	26.0 (66.0)	7 x 8 (2.1 x 2.4)	170 (76.5)	1623 (409)
2211M	5.5 (14.0)	8.0 (20.3)	11.5 (29.2)	3 x 3 (.9 x .9)*	15 (6.7)	85 (22)
2231W-3	10.0 (25.4)	24.0 (61.0)	18.0 (45.7)	6 x 6 (1.8 x 1.8)*	82 (37.0)	600 (151)
2231W-6	10.0 (25.4)	24.0 (61.0)	18.0 (45.7)	6 x 6 (1.8x 1.8)*	70 (31.4)	600 (151)
2233	9.5 (24.2)	26.4 (67.1)	20.8 (52.9)	4 x 4 (1.2 x 1.2)*	68 (30.6)	313 (78)
2235	9.5 (24.2)	26.4 (67.1)	20.8 (52.9)	4 x 4 (1.2 x 1.2)*	68 (30.6)	428 (107)
2236DE	13.5 (34.3)	19.8 (50.2)	20.5 (52.1)	4 x 4 (1.2 x 1.2)*	51 (22.9)	171 (43)
2236WD	13.5 (34.3)	19.8 (50.2)	20.5 (52.1)	4 x 4 (1.2 x 1.2)*	51 (22.9)	171 (43)
2245	4.2 (10.7)	14.7 (37.3)	12.0 (30.5)	2 x 2 (.6 x .6)*	12 (5.4)	92 (313)
2260C	10.3 (26.2)	19.0 (48.1)	30.7 (78.0)	5 x 8 (1.5 x 2.4)	130 (58.5)	1010 (265)
2270A-1	19.0 (48.3)	17.5 (44.5)	16.3 (41.4)	3 x 3 (.9 x .9)*	74 (33.3)	716 (180)
2270A-2	19.0 (48.3)	17.5 (44.5)	16.3 (41.4)	3 x 3 (.9 x .9)*	82 (36.9)	716 (180)
2270A-3	19.0 (48.3)	17.5 (44.5)	16.3 (41.4)	3 x 3 (.9 x .9)*	94 (42.3)	716 (180)
2273-1	43.8 (111)	30.5 (77.5)	25.1 (63.8)	5 x 7 (1.5 x 2.1)	198 (89.1)	1200 (302)
2273-2	43.8 (111)	30.5 (77.5)	25.1 (63.8)	5 x 7 (1.5 x 2.1)	198 (89.1)	1200 (302)
2280-1	36.0 (91.4)	20.5 (52.1)	33.0 (83.8)	5 x 8 (1.5 x 2.4)	200 (90.0)	3230 (814)
2280-2	36.0 (91.4)	20.5 (52.1)	33.0 (83.8)	5 x 8 (1.5 x 2.4)	200 (90.0)	3230 (814)
2280-3	36.0 (91.4)	20.5 (52.1)	33.0 (83.8)	5 x 8 (1.5 x 2.4)	200 (90.0)	3230 (814)
2280N-1	36.0 (91.4)	20.5 (52.1)	33.0 (83.8)	5 x 8 (1.5 x 2.4)	200 (90.0)	3230 (814)
2280N-2	36.0 (91.4)	20.5 (52.1)	33.0 (83.8)	5 x 8 (1.5 x 2.4)	200 (90.0)	3230 (814)
2280N-3	36.0 (91.4)	20.5 (52.1)	33.0 (83.8)	5 x 8 (1.5 x 2.4)	200 (90.0)	3230 (814)
2281W	9.0 (22.9)**	25.0 (63.5)	19.5 (49.5)	5 x 7 (1.5 x 2.1)*	70 (31.5)	1000 (252)
2281WC	9.0 (22.9)**	28.8 (73.0)	19.5 (49.5)	5 x 7 (1.5 x 2.1)*	70 (31.5)	1023 (258)
2282	13.5 (34.3)	19.8 (50.2)	20.5 (52.1)	4 x 4 (1.2 x 1.2)*	38 (17.5)	614 (155)
2286DE,DW	15.9 (40.4)	20.0 (50.8)	16.4 (41.7)	4 x 4 (1.2 x 1.2)*	49 (22.1)	171 (43)
2336DW	15.0 (38.1)	13.5 (34.3)	12.5 (31.8)	4 x 4 (1.2 x 1.2)*	30 (13.6)	350 (85)
DW/22-20	9.0 (22.9)	25.0 (63.5)	19.5 (49.5)	5 x 7 (1.5 x 2.1)	43 (19.4)	427 (107)

* Usually table mounted
** 12.5 in. (31.7 cm) with forms feeder

Table A-2. Site Planning Information (OIS/Alliance/WP Products)

Product	Height in. (cm)	Width in. (cm)	Depth in. (cm)	Recommended Floor Space Width x Depth ft (m)	Net Weight lb (kg)	Maximum Heat Dissipation Btu/hr (kg-cal/hr)
AWS-1	13.3 (33.7)	16.5 (42.0)	22.0 (55.9)	3.5 (.9x 1.5)	20 (9.1)	853 (215)
AWS-4	13.3 (33.7)	16.5 (42.0)	22.0 (55.9)	3.5 (.9x 1.5)	20 (9.1)	853 (215)
OIS 105 (6505)	14.2 (36.2)	21.2 (53.0)	23.0 (58.4)	3 x 5 (.9 x 1.5)	70 (31.5)	1058 (267)
OIS 115 (6515)	14.2 (36.2)	21.2 (53.0)	23.0 (58.4)	3 x 5 (.9 x 1.5)	70 (31.5)	1058 (267)
OIS 125A (6525A)	14.2 (36.2)	21.2 (53.0)	23.0 (58.4)	3 x 5 (.9 x 1.5)	40 (18.0)	1058 (267)
OIS 130A (6530A)	14.2 (36.2)	21.2 (53.0)	23.0 (58.4)	3 x 5 (.9 x 1.5)	40 (18.0)	1058 (267)
OIS 130B (6530B)	14.2 (36.2)	21.2 (53.0)	23.0 (58.4)	3 x 5 (.9 x 1.5)	40 (18.0)	1058 (267)
OIS 130C (6530C)	14.2 (36.2)	21.2 (53.0)	23.0 (58.4)	3 x 5 (.9 x 1.5)	40 (18.0)	1058 (267)
OIS 130D (6530D)	14.2 (36.2)	21.2 (53.0)	23.0 (58.4)	3 x 5 (.9 x 1.5)	40 (18.0)	1058 (267)
OIS 130E (6530E)	14.2 (36.2)	21.2 (53.0)	23.0 (58.4)	3 x 5 (.9 x 1.5)	40 (18.0)	1058 (267)
OIS 140 (6540)	28.5 (72.4)	24.0 (61.0)	30.0 (76.2)	3 x 5 (.9 x 1.5)	200 (90-0)	1570 (396)
OIS 145 (6545)	28.5 (72.4)	24.0 (61.0)	30.0 (76.2)	3 x 5 (.9 x 1.5)	200 (90.0)	1570 (396)
Wangwriter(5503/5504)	29.0 (74.0)	22.0 (56.0)	15.0 (38.0)	4 x 2 (1.2 x .6)	73 (33-0)	1010 (257)
WP 5 (5505-3)	13.3 (33.7)	16.5 (42.0)	22.0 (55.9)	3 x 5 (.9 x 1.5)	73 (33.0)	853 (215)
WP 20 (5520)	13.3 (33.7)	16.5 (42.0)	22.0 (55.9)	3 x 5 (.9 x 1.5)	73 (33-0)	853 (215)
WP 25 (5525-3)	13.3 (33.7)	16.5 (42.0)	22.0 (55.9)	3 x 5 (.9 x 1.5)	42 (19.0)	853 (215)
WP 30 (5530)	13.3 (33.7)	16.5 (42.0)	22.0 (55.9)	3 x 5 (.9 x 1.5)	42 (19.0)	853 (215)
5310,5320	15.0 (38.1)	13.5 (34.3)	12.5 (31.8)	4 x 4 (1.2 x 1.2)*	22 (10.0)	350 (85)
5330,5340	15.0 (38.1)	13.5 (34.3)	12.5 (31.8)	4 x 4 (1.2 x 1.2)*	22 (10.0)	350 (85)
5506-1	13.5 (34.3)	19.8 (50.2)	20.5 (52.0)	4 x 4 (1.2 x 1.2)*	54 (25.4)	521 (129)
5506-2,3	13.5 (34.3)	19.8 (50.2)	20.5 (52.0)	4 x 4 (1.2 x 1.2)*	54 (25.4)	521 (129)
5533,-1	9.5 (24.2)	26.4 (67.1)	20.8 (52.9)	4 x 4 (1.2 x 1.2)*	68 (30.6)	313 (78)
5535,-1	9.5 (24.2)	26.4 (67.1)	20.8 (52.9)	4 x 4 (1.2 x 1.2)*	68 (30.6)	428 (109)
5536-1,2,3,4	13.5 (34.3)	19.8 (50.2)	20.5 (52.0)	4 x 4 (1.2 x 1.2)*	54 (24.3)	605 (153)
5541W	9.0 (22.9)**	25.5 (63.5)	19.5 (44.5)	5 x 7 (1.5 x 2.1)*	70 (31.5)	1000 (252)
5541WC	9.0 (22.9)**	28.8 (73.0)	19.5 (49.5)	5 x 7 (1.5 x 2.1)*	70 (31.5)	1023 (258)
5548z	32.0 (81.3)	48.0 (122)	25.5 (64.8)	9 x 7 (2.7 x 2.1)	550 (250)	4000 (1008)
5556C	13.5 (34.3)	19.8 (50.2)	20.2 (52.0)	4 x 4 (1.2 x 1.2)*	54 (24.3)	605 (153)
5574	43.8 (111)	30.5 (77.5)	25.1 (63.8)	5 x 7 (1.5 x 2.1)	198 (89.1)	1200 (302)
5577	9.0 (22.9)	25.0 (63.5)	19.5 (49.5)	6 x 6 (1.8 x 1.8)*	50 (22.7)	1366 (341)
5581WD,-1	9.0 (22.9)**	42.0 (107)	20.5 (52.1)	6 x 7 (1.8 x 2.1)*	125 (56.7)	1705 (430)
5816-1***	15.9 (40.4)	20.0 (50.8)	16.4 (41.7)	4 x 4 (1.2 x 1.2)*	59 (27.0)	426 (107)
5917+	15.9 (40.4)	20.0 (50.8)	16.4 (41.7)	4 x 4 (1.2 x 1.2)*	64 (29.0)	819 (207)
5918++	15.9 (40.4)	20.0 (50.8)	16.4 (41.7)	4 x 4 (1.2 x 1.2)*	64 (29.0)	819 (207)
5919+++	15.9 (40.4)	20.0 (50.8)	16.4 (41.7)	4 x 4 (1.2 x 1.2)*	64 (29.0)	819 (207)
6340	15.0 (38.1)	13.5 (34.3)	12.5 (31.8)	4 x 4 (1.2 x 1.2)*	22 (10.0)	350 (85)
6509	34.5 (87.6)	24.0 (61.0)	26.0 (66.0)	7 x 8 (2.1 x 2.4)	170 (76.5)	1623 (409)
6550-1 (WISE)	13.0 (33.0)	16.0 (40.6)	21 (53.3)	3 x 7 (.9 x 2.1)	50 (22.5)	510 (129)
6560	28.0 (71.1)	19.0 (48.1)	30.7 (78.0)	5 x 8 (1.5 x 2.4)	130 (58.5)	1050 (265)
6560A	28.0 (71.1)	19.0 (48.1)	30.7 (78.0)	5 x 8 (1.5 x 2.4)	130 (58.5)	1050 (265)
6560B	28.0 (71.1)	19.0 (48.1)	30.7 (78.0)	5 x 8 (1.5 x 2.4)	130 (58.5)	1050 (265)

Table A-2. Site Planning Information (OIS/Alliance/WP Products) (continued)

Product	Height in. (cm)	Width in. (cm)	Depth in. (cm)	Recommended Floor Space Width x Depth ft (m)	Net Weight lb (kg)	Maximum Heat Dissipation Btu/hr (kg-cal/hr)
6560C	28.0 (71.1)	19.0 (48.1)	30.7 (78.0)	5 x 8 (1.5 x 2.4)	130 (58.5)	1050 (265)
6565	41.0 (104)	24.0 (61.0)	36.0 (91.4)	5 x 8 (1.5 x 2.4)	550 (247.5)	3960 (998)
6580-1	36.0 (91.4)	20.5 (52.1)	33.0 (83.8)	5 x 8 (1.5 x 2.4)	200 (90.0)	3230 (814)
6580-2	36.0 (91.4)	20.5 (52.1)	33.0 (83.8)	5 x 8 (1.5 x 2.4)	200 (90.0)	3230 (814)
6580-3	36.0 (91.4)	20.5 (52.1)	33.0 (83.8)	5 x 8 (1.5 x 2.4)	200 (90.0)	3230 (814)
6581W,-1	9.0 (22.9)**	25.5 (63.5)	19.5 (49.5)	5 x 7 (1.5 x 2.1)*	70 (31.5)	1000 (252)
6581WC,-1	9.0 (22.9)**	28.8 (73.0)	19.5 (49.5)	5 x 7 (1.5 x 2.1)*	70 (31.5)	1023 (258)
6750	28.5 (72.4)	24.0 (61.0)	30.0 (76.2)	3 x 5 (.9 x 1.5)	200 (90.0)	1570 (396)
DW/WP-20	9.0 (22.9)	25.0 (63.5)	19.5 (49.5)	5 x 7 (1.5 x 2.1)*	43 (19.4)	427 (107)
DW/5-20	9.0 (22.9)	25.0 (63.5)	19.5 (49.5)	5 x 7 (1.5 x 2.1)*	43 (19.4)	427 (107)
DW/OS-20	9.0 (22.9)	25.0 (63.5)	19.5 (49.5)	5 x 7 (1.5 x 2.1)	43 (19.4)	427 (107)
LPS-12	36.0 (91.4)	25.8 (65.5)	26.0 (66.0)	4 x 4 (1.2 x 1.2)	285 (129)	3413 (1104)
<p>* Usually table mounted + including 5927, 5937, 5947 ** 12.5 in. (31.7 cm) with forms feeder ++ including 5928, 5938, 5948 *** 5826, 5836, and 5846 types are similar +++ including 5929, 5939, 5949</p>						

Table A-3. Site Planning Information (VS Products)

Product	Height in. (cm)	Width in. (cm)	Depth in. (cm)	Recommended Floor Space Width x Depth ft (m)	Net Weight lb (kg)	Maximum Heat Dissipation Btu/hr (kg-cal/hr)
VS 25	36.0 (91.4)	27.0 (68.6)	26.5 (67.3)	3 x 8 (.9 x 2.4)	250 (112.5)	2500 (625)
VS 45	36.0 (91.4)	27.0 (68.6)	26.5 (67.3)	3 x 8 (.9 x 2.4)	250 (112.5)	2500 (625)
VS 50	41.0 (104)	35.5 (90.2)	31.5 (80.0)	3 x 8 (.9 x 2.4)	353 (158.8)	6000 (1512)
VS 80	41.0 (104)	35.5 (90.2)	31.5 (80.0)	3 x 8 (.9 x 2.4)	353 (158.8)	6000 (1512)
VS 90	41.0 (104)	35.5 (90.2)	31.5 (80.0)	3 x 8 (.9 x 2. (158.8)	6000 (1512)	
VS 100	41.0 (104)	48.0 (122.0)	32.0 (81.0)	4 x 8 (1.2 x 2.4)	537 (244)	8000 (2000)
AWS Diskette Drive (2266S-1, S-2, S-3) (2266C-1, C-3) (2276C-1, C-3)	13.3 (33.8)	16.5 (41.9)	22.0 (55.9)	3 x 5 (.9 x 1.5)	65 (29.3)	710 (180)
2209V	34.5 (87.6)	24.0 (61.0)	26.0 (66.0)	7 x 8 (2.1 x 2.4)	170 (76.5)	1623 (409)
2209V-2	34.5 (87.6)	24.0 (61.0)	26.0 (66.0)	7 x 8 (2.1 x 2.4)	170 (76.5)	1623 (409)
2209V-2B	34.5 (87.6)	24.0 (61.0)	26.0 (66.0)	7 x 8 (2.1 x 2.4)	170 (76.5)	1623 (409)
2209V-3	34.5 (87.6)	24.0 (61.0)	26.0 (66.0)	7 x 8 (2.1 x 2.4)	170 (76.5)	1623 (409)
2209V-3B	34.5 (87.6)	24.0 (61.0)	26.0 (66.0)	7 x 8 (2.1 x 2.4)	170 (76.5)	1623 (409)
2209V-B	34.5 (87.6)	24.0 (61.0)	26.0 (66.0)	7 x 8 (2.1 x 2.4)	170 (76.5)	1623 (409)
2219V-1	59.0 (152)	24.0 (61.0)	26.0 (66.0)	7 x 8 (2.1 x 2.4)	170 (76.5)	1623 (409)
2219V-1B	59.0 (152)	24.0 (61.0)	26.0 (66.0)	7 x 8 (2.1 x 2.4)	450 (204.5)	4915 (1057)
2219V-3	59.0 (152)	24.0 (61.0)	26.0 (66.0)	7 x 8 (2.1 x 2.4)	450 (204.5)	4915 (1057)
2219V-3B	59.0 (152)	24.0 (61.0)	26.0 (66.0)	7 x 8 (2.1 x 2.4)	450 (204.5)	4915 (1057)
2233R	9.5 (24.2)	26.4 (67.1)	20.8 (52.9)	4 x 4 (1.2 x 1.2)	68 (30.6)	313 (78)
2235R	9.5 (24.2)	26.4 (67.1)	20.8 (52.9)	4 x 4 (1.2 x 1.2)	68 (30.6)	428 (107)
2244V	13.5 (34.3)	19.3 (49.0)	14.8 (37.5)	2 x 6 (.6 x 1.8)*	35 (15.8)	597 (150)
2246C	13.0 (33.0)	19.5 (49.5)	20.5 (52.1)	4 x 4 (1.2 x 1.2)*	40 (18.0)	427 (108)
2246R	13.0 (33.0)	19.5 (49.5)	20.5 (52.1)	4 x 4 (1.2 x 1.2)*	40 (18.0)	427 (108)
2246S	13.0 (33.0)	19.5 (49.5)	20.5 (52.1)	4 x 4 (1.2 x 1.2)*	40 (18.0)	427 (108)
2247V-4	6.0 (15.2)	8.0 (20.3)	12.0 (30.5)	1 x 3 (.3 x .9)	9 (4.0)	200 (50)
2256C	13.0 (33.0)	19.5 (49.5)	20.5 (52.1)	4 x 4 (1.2 x 1.2)*	40 (18.0)	427 (108)
2265V-1	41.0 (104)	24.0 (61.0)	36.0 (91.4)	5 x 8 (1.5 x 2.4)	500 (225)	3218 (811)
2265V-2	41.0 (104)	24.0 (61.0)	36.0 (91.4)	5 x 8 (1.5 x 2.4)	550 (247.5)	4096 (1032)
2266C-1,C-3	13.5 (34.3)	19.8 (50.8)	20.5 (52.1)	4 x 4 (1.2 x 1.2)*	38 (17.3)	102 (26)
2266S-1,S-2,S-3	13.5 (34.3)	19.8 (50.8)	20.5 (52.1)	4 x 4 (1.2 x 1.2)*	38 (17.3)	102 (26)
2273V-1	43.8 (111)	30.5 (77.5)	25.1 (63.8)	5 x 7 (1.5 x 2.1)	198 (89.1)	1200 (302)
2280V-1	36.0 (91.4)	20.5 (52.1)	33.0 (83.8)	5 x 8 (1.5 x 2.4)	200 (90.0)	3230 (814)
2280V-2	36.0 (91.4)	20.5 (52.1)	33.0 (83.8)	5 x 8 (1.5 x 2.4)	200 (90.0)	3230 (814)
2280V-3	36.0 (91.4)	20.5 (52.1)	33.0 (83.8)	5 x 8 (1.5 x 2.4)	200 (90.0)	3230 (814)
2281WCR	9.0 (22.9)**	28.8 (73.0)	19.5 (49.5)	5 x 7 (1.5 x 2.1)*	70 (31.5)	1023 (258)
2281WR	9.0 (22.9)**	25.0 (63.5)	19.5 (49.5)	5 x 7 (1.5 x 2.1)*	70 (31.5)	1000 (252)
286C-1,2,3,4,5	13.5 (34.3)	19.8 (50.8)	20.5 (52.1)	4 x 4 (1.2 x 1.2)*	38 (17.3)	102 (26)
2866C,C4,R,5	13.0 (33.0)	19.5 (49.5)	20.5 (52.1)	4 x 4 (1.2 x 1.2)*	40 (18.0)	427 (108)
5310,5320	15.0 (38.1)	13.5 (34.3)	12.5 (31.8)	4 x 4 (1.2 x 1.2)*	22 (10.0)	350 (85)
5330,5340	15.0 (38.1)	13.5 (34.3)	12.5 (31.8)	4 x 4 (1.2 x 1.2)*	22 (10.0)	350 (85)

Table A-3. Site Planning Information (VS Products) (continued)

Product	Height in. (cm)	Width in. (cm)	Depth in. (cm)	Recommended Floor Space Width x Depth ft (m)	Net Weight lb (kg)	Maximum Heat Dissipation Btu/hr (kg-cal/hr)
5548z	35.0 (90.0)	48.0 (122.0)	25.0 (63.5)	9 x 7 (2.7 x 2.1)	550 (250)	4000 (1008)
5573	43.8 (111)	30.5 (77.5)	25.1 (63.8)	5 x 7 (1.5 x 2.1)	198 (89.1)	1200 (302)
5574	43.8 (111)	30.5 (77.5)	25.1 (63.8)	5 x 7 (1.5 x 2.1)	198 (89.1)	1200 (302)
5575	42.0 (107)	36.5 (92.7)	32.0 (81.3)	7 x 8 (2.1 x 2.4)	570 (256.5)	2700 (680)
5577	9.0 (22.9)	25.0 (63.5)	19.5 (49.5)	6 x 6 (1.8 x 1.8)	50 (22.7)	1366 (341)
6340	15.0 (38.1)	13.5 (34.3)	12.5 (31.8)	4 x 4 (1.2 x 1.2)*	22 (10.0)	350 (85)
6581W	9.0 (22.9)**	25.0 (63.5)	19.5 (49.5)	5 x 7 (1.5 x 2.1)*	70 (31.5)	1000 (252)
6581WC	9.0 (22.9)**	25.0 (63.5)	19.5 (49.5)	5 x 7 (1.5 x 2.1)*	70 (31.5)	1023 (259)
DW/R-20	9.0 (22.9)	25.0 (63.5)	19.5 (49.5)	5 x 7 (1.5 x 2.1)*	43 (19.4)	427 (107)
LPS-12	36.0 (91.4)	25.8 (65.5)	26.0 (66.0)	5 x 5 (1.5 x 1.5)	285 (129.0)	3413 (1104)
<p>* Usually table mounted ** 12.5 in. (31.7 cm) with forms feeder</p>						

Table A-4. Site Planning Information (7500T Products)

Product	Height in. (cm)	Width in. (cm)	Depth in. (cm)	Recommended Floor Space Width x Depth ft (m)	Net Weight lb (kg)	Maximum Heat Dissipation Btu/hr (kg-cal/hr)
7505T	28.4 (72.1)	23.4 (59.4)	26.6 (67.6)	3 x 5 (.9 x 1.5)	200 (91)	1573 (396)
7510T	12.8 (32.5)	20.5 (52.1)	33.0 (83.8)	5 x 8 (1.5 x 2.4)	198 (90)	1111 (280)
7510TA	12.8 (32.5)	20.5 (52.1)	33.0 (83.8)	5 x 8 (1.5 x 2.4)	198 (90.0)	1111 (280)
7511T	12.8 (32.5)	20.5 (52.1)	33.0 (83.8)	5 x 8 (1.5 x 2.4)	198 (90.0)	1111 (280)
7511TA	12.8 (32.5)	20.5 (52.1)	33.0 (83.8)	5 x 8 (1.5 x 2.4)	198 (90.0)	1111 (280)
7515T	28.4 (72.1)	23.4 (59.4)	26.6 (67.6)	3 x 5 (.9 x 1.5)	200 (91)	1573 (396)
7520T	13.3 (33.6)	16.5 (42.0)	22.0 (55.9)	3 x 5 (.9 x 1.5)	72 (32.6)	853 (215)
7525-3T	13.3 (33.6)	16.5 (42.0)	22.0 (55.9)	3 x 5 (.9 x 1.5)	68 (30.6)	605 (153)
7526HT	13.5 (34.3)	19.8 (50.2)	20.5 (52.0)	4 x 4 (1.2 x 1.2)*	54 (24.3)	1573 (396)
7530T	13.3 (33.6)	16.5 (42.0)	22.0 (55.9)	3 x 5 (.9 x 1.5)	68 (30.6)	605 (153)
7535T	28.4 (72.1)	23.4 (59.4)	26.6 (67.6)	3 x 5 (.9 x 1.5)*	200 (91)	1573 (396)
7536-1T	13.5 (34.3)	19.8 (50.3)	20.5 (52.1)	4 x 4 (1.2 x 1.2)*	54 (24.3)	605 (153)
7536-2T	13.5 (34.3)	19.8 (50.3)	20.5 (52.1)	4 x 4 (1.2 x 1.2)*	54 (24.3)	605 (153)
7536-4T	13.5 (34.3)	19.8 (50.3)	20.5 (52.1)	4 x 4 (1.2 x 1.2)*	54 (24.3)	605 (153)
7540T	28.4 (72.1)	23.4 (59.4)	26.6 (67.6)	3 x 5 (.9 x 1.5)	200 (91)	1573 (396)
7550T	28.4 (72.1)	23.4 (59.4)	26.6 (67.6)	3 x 5 (.9 x 1.5)	200 (91)	1573 (396)
7565-1T	39.9 (101.3)	20.4 (51.8)	34.1 (86.6)	5 x 8 (1.5 x 2.4)	500 (227)	3224 (812)
7565-1TA	39.9 (101.3)	20.4 (51.8)	34.1 (86.6)	5 x 8 (1.9 x 2.4)	500 (227)	3224 (812)
7581WT	15.0 (38.1)	26.0 (66.0)	21.0 (53.3)	5 x 7 (1.5 x 2.1)*	91 (41)	1026 (259)
7581WCT	15.0 (38.1)	31.0 (78.7)	21.0 (53.3)	5 x 7 (1.5 x 2.1)*	101 (45.9)	1026 (259)
7581W-1T	15.0 (38.1)	26.0 (66.0)	21.0 (53.3)	5 x 7 (1.5 x 2.1)*	91 (41)	1026 (259)
7581WC-1T	15.0 (38.1)	31.0 (78.7)	21.0 (53.3)	5 x 7 (1.5 x 2.1)*	101 (45.9)	1026 (259)
OCR-T, TCB-T	7.8 (19.8)	9.2 (23.4)	19.3 (49.0)	5 x 7 (1.5 x 2.1)*	18 (8.2)	342 (86)
TC-7536-T	13.5 (34.3)	19.8 (50.3)	20.5 (52.1)	4 x 4 (1.2 x 1.2)*	54 (24.5)	605 (153)
TC-7536-4T	13.5 (34.3)	19.8 (50.3)	20.5 (52.1)	4 x 4 (1.2 x 1.2)*	54 (24.5)	605 (153)

* Usually table mounted

Table A-5. Site Planning Information (Furniture)

Product	Height in. (cm)	Width in. (cm)	Depth in. (cm)	Net Weight lb (kg)
CET-1	28.5(72.4)	24(61)	30(76.2)	35(15.8)
8017-5	28.5(72.4)	24(61)	30(76.2)	35(15.8)
FST-1	28.5(72.4)	24(61)	30(76.2)	150(67.9)
MT-1	28.5(72.4)	45(114.3)	30(76.2)	155(69.8)
WST-1	28.5(72.4)	32(81.3)	30(76.2)	89(40.1)
8009-5	28.5(72.4)	32(81.3)	30(76.2)	89(40.1)
2297	22.5(57.2)	20.5(52.1)	30.5(77.5)	55(24.8)
8005-5	27.3(69.3)	24.3(61.6)	36(91.4)	37(16.8)
8007-5	28.5(72.4)	45(114.3)	30(76.2)	121(54.5)
8002-5	28.5(72.4)	45(114.3)	30(76.2)	121(54.5)
8001-5	28.5(72.4)	32(81.3)	30(76.2)	82(37.0)

Table A-6. Workstations/Terminals

Model	Product Line	Description
5536-1	WP	16K CRT/Keyboard Workstation
5536-2	OIS ALLIANCE	32K CRT/Keyboard Workstation
5536-3	OIS ALLIANCE	48K CRT/Keyboard Workstation
5536-4	OIS ALLIANCE	64K CRT/Keyboard Workstation
5536IWS	OIS	Ideographic Workstation
5556C	OIS	64K CRT/Keyboard Workstation for word processing and data processing applications within Remote Cluster
—	OIS	48K Archiving Workstation for the AWS-1
—	OIS	64K Archiving Workstation for the AWS-4
7526HT	WP	16K CRT/Keyboard Workstation
7536-IT	WP	16K CRT/Keyboard Workstation upgradable to 32K/64K memory and TC configuration
7536-2T	OIS	32K CRT/Keyboard Workstation
7536-4T	OIS ALLIANCE	64K CRT/Keyboard Workstation
TC-7536-2T	WP/OIS	32K CRT/Keyboard Workstation for telecommunications
TC-7536-4T	OIS	64K CRT/Keyboard Workstation for telecommunications

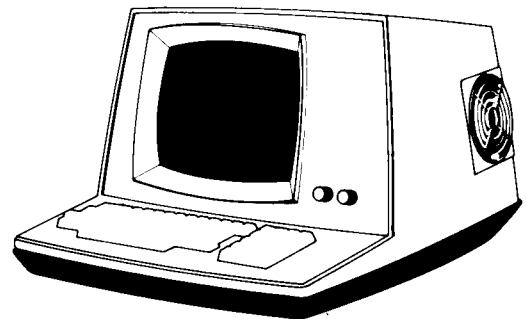

Model	Product Line	Description
5917	OIS ALLIANCE	64K Minidiskette Archiving Workstation (48 keys)
5919	OIS ALLIANCE	Proportional Space 64K Minidiskette Archiving Workstation (48 keys)
5927	OIS ALLIANCE	64K Minidiskette Archiving Workstation (48 keys) with numeric keypad
5929	OIS ALLIANCE	Proportional Space 64K Minidiskette Archiving Workstation (48 keys) with numeric keypad
5937	OIS ALLIANCE	64K Minidiskette Archiving Workstation (44 keys)
5939	OIS ALLIANCE	Proportional Space 64K Minidiskette Archiving Workstation (44 keys)
5947	OIS ALLIANCE	64K Minidiskette Archiving Workstation (44 keys) with numeric keypad
5949	OIS ALLIANCE	Proportional Space 64K Minidiskette Archiving Workstation (44 keys) with numeric keypad
TC-5917	OIS	64K Minidiskette Archiving Workstation (48 keys) with TC
TC-5927	OIS	64K Minidiskette Archiving Workstation (48 keys) with TC and numeric keypad
TC-5937	OIS	64K Minidiskette Archiving Workstation (44 keys) with TC

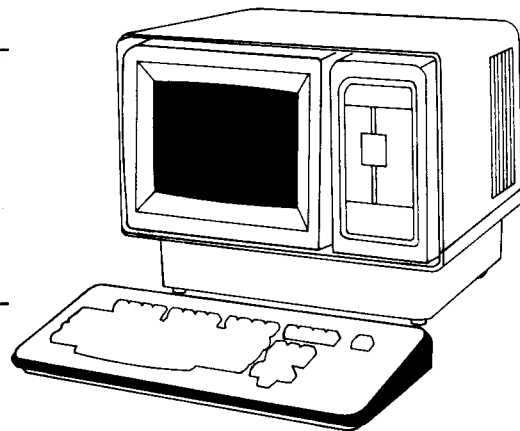

Model	Product Line	Description
TC-5947	OIS	64K Minidiskette Archiving Workstation (44 keys) with TC and numeric keypad
TC-5919	OIS	64K Proportional Space Minidiskette Archiving Workstation (48 keys) with TC
TC-5929	OIS	64K Proportional Space Minidiskette Archiving Workstation (48 keys) with TC and numeric keypad
TC-5939	OIS	64K Proportional Space Minidiskette Archiving Workstation (44 keys) with TC
TC-5949	OIS	64K Proportional Space Minidiskette Archiving Workstation (44 keys) with TC and numeric keypad

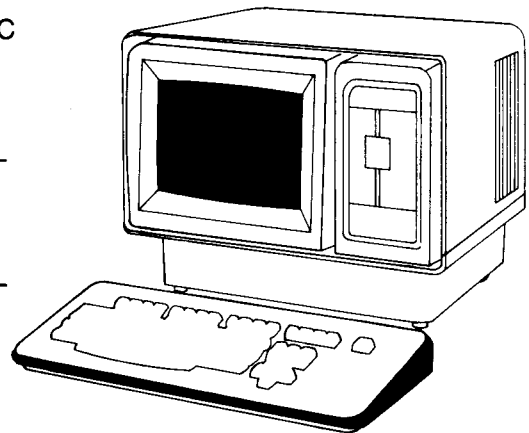

Model	Product Line	Description
5816-1	WP	16K Ergo 2 Workstation (48 keys)
5826-1	WP	16K Ergo 2 Workstation (48 keys) with numeric keypad
TC-5816-2	WP	32K Ergo 2 Workstation (48 keys) with TC
TC-5826-2	WP	32K Ergo 2 Workstation (48 keys) with TC and numeric keypad
5816-4	OIS ALLIANCE	64K Ergo 2 Workstation
5826-4	OIS ALLIANCE	64K Ergo 2 Workstation (48 keys) with numeric keypad
TC-5816-4	OIS	64K Ergo 2 Workstation (48 keys) with TC
TC-5826-4	OIS	64K Ergo 2 Workstation (48 keys) with TC and numeric keypad
5836-1	WP	16K Ergo 2 Workstation (44 keys)
5846-1	WP	16K Ergo 2 Workstation (44 keys) with numeric keypad
TC-5836-2	WP	32K Ergo 2 Workstation (44 keys) with TC
TC-5846-2	WP	32K Ergo 2 Workstation (44 keys) with TC and numeric keypad
5836-4	OIS ALLIANCE	64K Ergo 2 Workstation (44 keys) with numeric keypad
TC-5836-4	OIS	64K Ergo 2 Workstation (44 keys) with TC

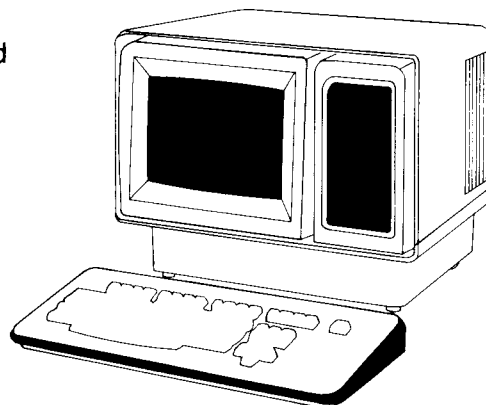

Model	Product Line	Description
TC-5846-4	OIS	64K Ergo 2 Workstation (44 keys) with TC and numeric keypad
5918	OIS ALLIANCE	Proportional space 64K Workstation (48 keys)
5928	OIS ALLIANCE	Proportional space 64K Workstation (48 keys) with numeric keypad
TC-5918	OIS	Proportional space 64K Workstation (48 keys) with TC
TC-5928	OIS	Proportional space 64K Workstation (48 keys) with TC and numeric keypad
5938	OIS ALLIANCE	Proportional space 64K Workstation (44 keys)
5948	OIS ALLIANCE	Proportional space 64K Workstation (44 keys) with numeric keypad
TC-5938	OIS	Proportional space 64K Workstation (44 keys) with TC
TC-5948	OIS	Proportional space 64K Workstation (44 keys) with TC and numeric keypad
2885DE	2200	Interactive Data Processing Workstation with standard keyboard
2886DW	2200	Integrated Data Processing and Word Processing Terminal with standard keyboard.

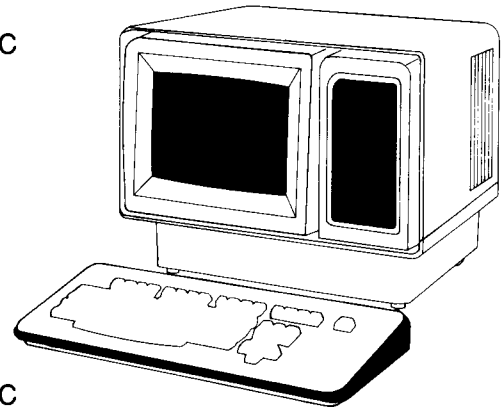

Model	Product Line	Description
2246C, 2866C	VS	Combined Workstation
2246R, 2866R	VS	Remote Workstation
2246S, 2866S	VS	Serial Workstation
2246S-1, S-2, S-3	VS	Serial KEYENTRY Workstation
2256C, 2866C-4	VS	64K Combined Workstation
2266S-1, S-2, S-3, 8860-3,4,5	VS	Serial Archiving Workstation
2266C-1, C-3 2860-1,2	VS	Combined Archiving Workstation
2276C-1, C-3	VS	64K Combined Archiving Workstation

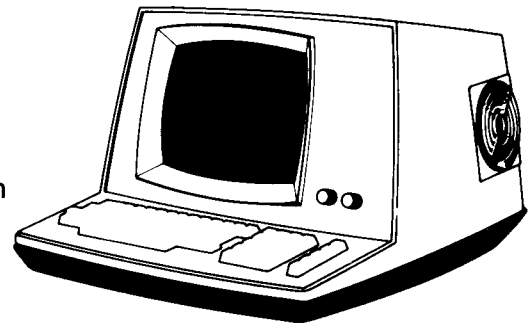

Model	Product Line	Description
2236DE	2200	Interactive Data Processing Terminal
2236DW	2200	Integrated Data Processing and Word Processing Terminal

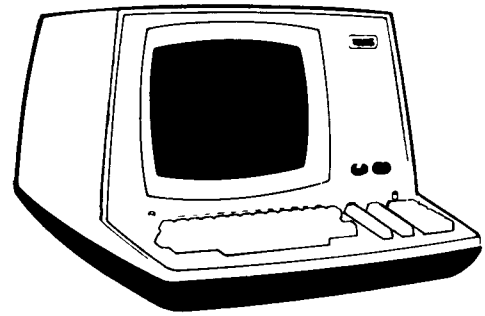

2336DW	2200	Integrated DP/WP Ergonomic Workstations
5310	ALLIANCE	Green Display Audio Workstation
5320	OIS,VS ALLIANCE	Green Display Workstation
5330	ALLIANCE	Black/White Audio Workstation
5340	OIS,VS ALLIANCE	Black on White Display Workstation
6340	OIS,VS	Black/White Graphic Display

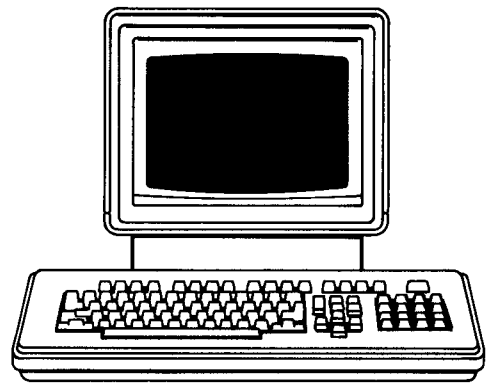
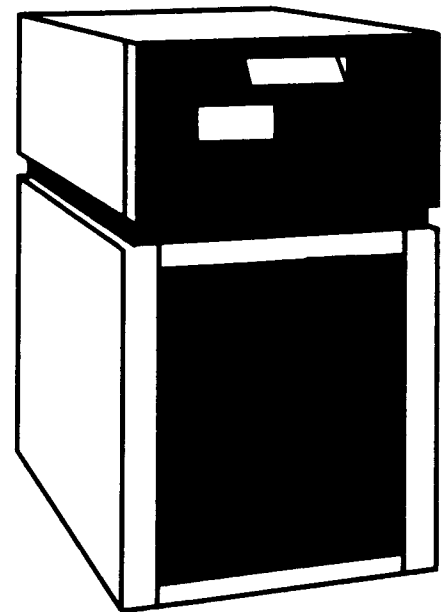
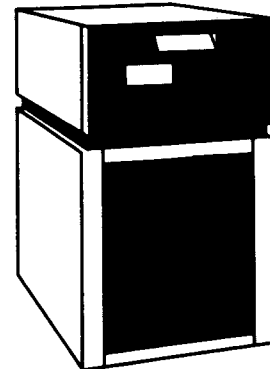

Table A-7. Disk Drives/Magnetic Tape Drives

Model	Product Line	Description
6580	OIS	System Disk Drive for OIS 140 (26.8, 53.6, or 80.4 Mb)
6580	ALLIANCE	System Disk Drive for ALLIANCE (80.4 Mb)
6580-1	OIS	Optional 26.8 Mb Disk Drive for OIS 140 Model 1
6580-2	OIS	Optional 53.6 Mb Disk Drive for OIS 140 Model 2
6580-3	OIS ALLIANCE	Optional 80.4 Mb Disk Drive for OIS 140 Model 3
2280-1	2200	13.4 Mb Removable and 13.4 Mb Fixed Disk Drive (26.8 Mb total)
2280-2	2200	13.4 Mb Removable and 40.2 Mb Fixed Disk Drive (53.6 Mb total)
2280-3	2200	13.4 Mb Removable and 67 Mb Fixed Disk Drive (80.4 Mb total)
2280N-1	2200	13.4 Mb Removable and 13.4 Mb Fixed Disk Drive (26.8 Mb total)
2280N-2	2200	13.4 Mb Removable and 40.2 Mb Fixed Disk Drive (53.6 Mb total)
2280N-3	2200	13.4 Mb Removable and 67 Mb Fixed Disk Drive (80.4 Mb total)



Model	Product Line	Description
2280V-1	VS	15 Mb Removable, 15 Mb Fixed Disk Drive (30 Mb total)
2280V-2	VS	15 Mb Removable, 45 Mb Fixed Disk Drive (60 Mb total)
2280V-3	VS	15 Mb Removable, 75 Mb Fixed Disk Drive (90 Mb total)



6565	OIS ALLIANCE	Optional 275 Mb Disk Drive for OIS 145/ALLIANCE
2265V-1	VS	75 Mb Removable Disk Drive
2265V-2	VS	288 Mb Removable Disk Drive
7565-1T	OIS ALLIANCE	80 Mb Removable Disk Drive (primary)
7565-1TA	OIS ALLIANCE	80 Mb Removable Disk Drive (additional)

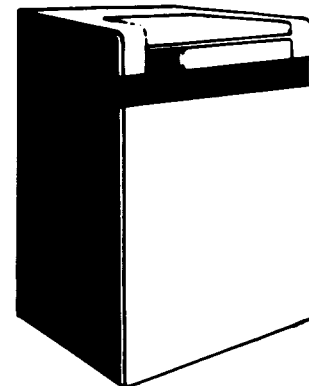

2270A-1	2200	Single Removable Diskette Drive (.25 Mb diskette)
2270A-2	2200	Dual Removable Disk Drive (two .25 Mb diskettes)
2270A-3	2200	Triple Removable Disk Drive (three .25 Mb diskettes)

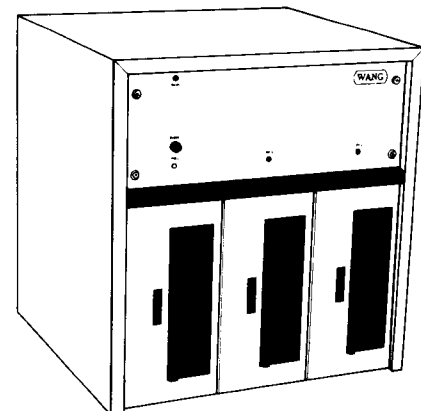

Model	Product Line	Description
6560	OIS ALLIANCE	First Optional 10 Mb Disk Drive for OIS 140/ALLIANCE, standard Drive for OIS 145
6560A	OIS	Second Optional 5/10 Mb Disk Drive for OIS 125A, 130A, 140 or 145
6560B	OIS	Optional 5 Mb Disk Drive for OIS 125A
6560C	OIS	Optional 10 Mb Disk Drive for OIS 130A
2260C*	2200	5 Mb Removable and 5 Mb Fixed Disk Drive
7510T	WP/OIS ALLIANCE	10 Mb Fixed-removable Disk Drive
7511T	WP/OIS ALLIANCE	5 Mb Fully Removable Disk Drive
7510TA	OIS ALLIANCE	Second 10 Mb Fixed-removable Disk Drive
7511TA	OIS ALLIANCE	Second 5 Mb Fully Removable Disk Drive

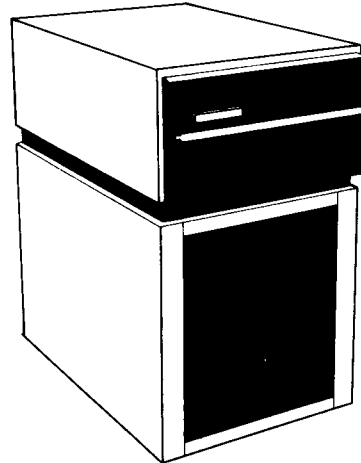

*Stand is optional

Model	Product Line	Description
6509	OIS ALLIANCE	9-Track, 1600 bpi Tape Drive and Controller (option to OIS Master)
2209A	2200	9-Track, 1600 bpi Tape Drive and Controller
2209V	VS	9-Track, 1600 bpi Tape Drive
2209V-B	VS	9-Track, 1600 bpi Tape Drive (Prerequisite is a 2209V. Used for Drives 2 through 4.)
2209V-2	VS	9-Track, 800/1600 bpi Tape Drive
2209V-2B	VS	9-Track, 1600 bpi Tape Drive (Prerequisite is a 2209V-2. Used for Drives 2 through 4.)
2209V-3	VS	7-Track, 800 bpi Tape Drive
2209V-3B	VS	7-Track, 800 bpi Tape Drive (Prerequisite is a 2209V-3. Used for Drives 2 through 4.)

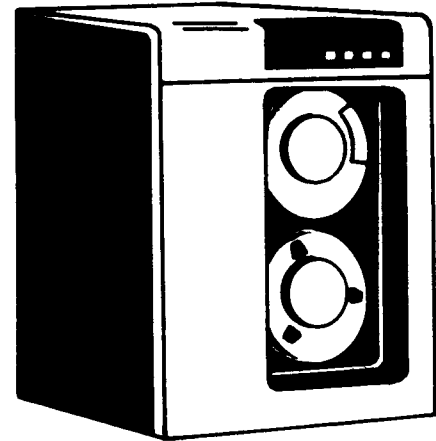

2219V-1(B)	VS	9-Track, Dual-Density (1600/6250 bpi) Tape Drive
2219V-3(B)	VS	9-Track, Tri-Density (800/1600/6250 bpi) Tape Drive

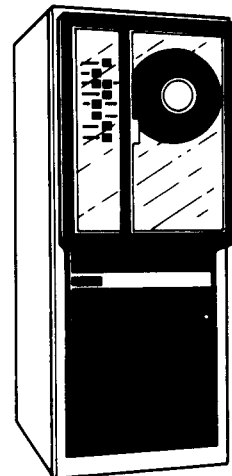
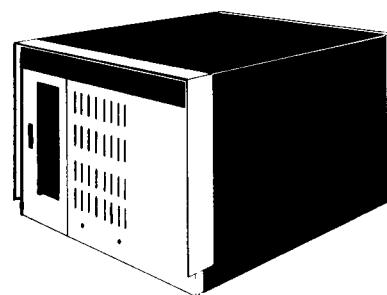
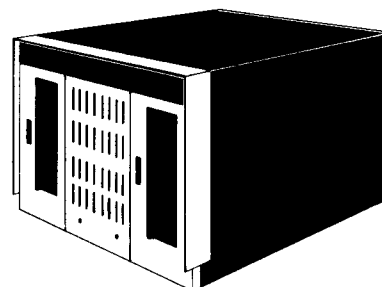

Table A-8. Central Processors/Master Processors

Model	Product Line	Description
5525-3	WP	WP System 25 Model III Master with Single Diskette (Supports Model 6560 type 5 Mb Disk Drive)
5530	WP	WP System 30 Master with Single Diskette (Supports Model 6560 type 10 Mb Disk Drive)
AWS-1	OIS	Single Diskette Drive (for 48K Archiving Workstation)
AWS-4	OIS ALLIANCE	Single Diskette Drive (for 65K Archiving Workstation)
2266C-1, C-3 2266S-1, S-2, S-3 2276C-1 2276C-3	VS	VS Archiving Workstation Master and Single Diskette
7525-3T	WP	14-Port Master, 5 Mb Disk, Single Diskette
7530T	WP	14-Port Master, 10 Mb Disk, Single Diskette



5520	WP	WP System 20 Master With Dual Diskette
7520T	WP	6 Port Master, Dual Diskettes, 7526HT Workstation, 7581WT Printer



Model	Product Line	Description
6505-1	OIS	OIS 105-1 Master with 4.2 Mb Sealed Disk and Single Diskette Drive
6515-2	OIS	OIS 115-2 Master with 8.4 Mb Sealed Disk and Single Diskette Drive
6515-3	OIS	OIS 115-3 Master with 16.0 Mb Sealed Disk and Single Diskette Drive
6515-4	OIS	OIS 115-4 Master with 32.0 Mb Sealed Disk and Single Diskette Drive
6530A	OIS	OIS 130A Master with Single Diskette Drive (Supports Model 6560 type 10 Mb Disk Drive)
6530B	OIS	OIS 130B Master with Single Diskette, 4 Mb Sealed Disk, and 10 Mb Disk Drive
6530C	OIS	OIS 130C Master with Single Diskette, 8 Mb Sealed Disk, and 10 Mb Disk Drive
6530D	OIS	OIS 130D Master with Single Diskette, 16 Mb Sealed Disk, and 10 Mb Disk Drive
6530E	OIS	OIS 130E Master with Single Diskette, 32 Mb Sealed Disk, and 10 Mb Disk Drive

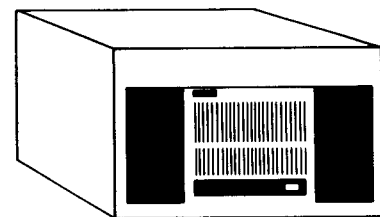

Model	Product Line	Description
6540-1	OIS	OIS 140 Model 1 Master with Single Diskette Drive (Supports Model 6580 type 26.8 Mb Disk Drive)
6540-2	OIS	OIS 140 Model 2 Master with Single Diskette Drive (Supports Model 6580 type 53.6 Mb Disk Drive)
6540-3	OIS	OIS 140 Model 3 Master with Single Diskette Drive (Supports Model 6580 type 80.4 Mb Disk Drive)
6545	OIS	OIS 145 Master with Single Diskette Drive (Supports Model 6565 type 275 Mb Disk Drive)
6750	ALLIANCE	ALLIANCE 250 Master with 128K Memory and 32 Ports, supports 6580 or 6565 Disk Drive
7505T	OIS	Master, Single Diskette, 7511T 5 Mb Disk Drive, 7536-2T Workstation, 7581WT Printer
7515T	OIS	8-Port Master, Single Diskette
7535T	OIS	16-Port Master, Single Diskette
7540T	OIS	32-Port Master, Single Diskette
7550T	ALLIANCE	32-Port Master, 128K memory, Single Diskette, Alliance Operating System

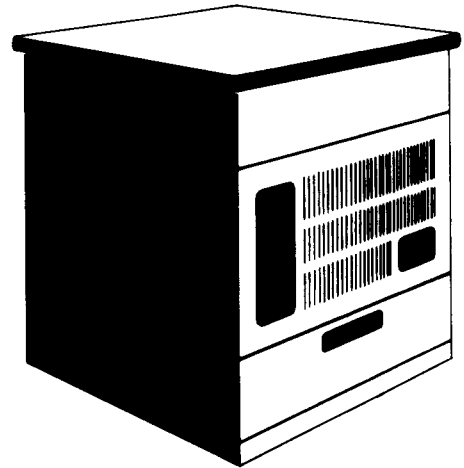

Model	Product Line	Description
5503	Wangwriter	Console and Printer with 96K memory
5504	Wangwriter	Console and Printer with 128K memory

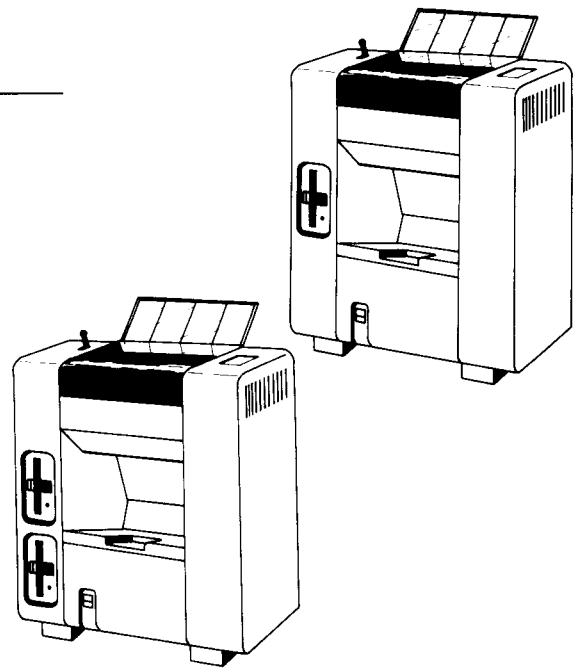

LVP | 2200 | CPU, Diskette, Winchester Disk

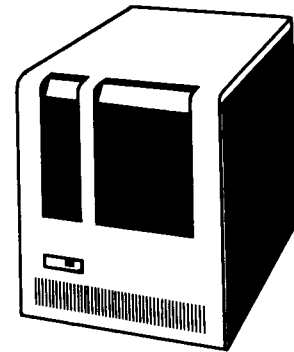

MVP | 2200 | CPU

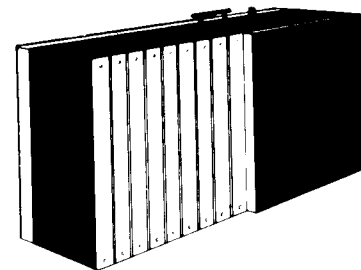

Model	Product Line	Description
SVP	2200	CPU, Diskette(s), Winchester Disk

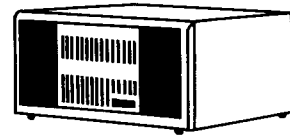

VS-25	VS	CPU, Diskette, Fixed Disk
VS-45	VS	CPU, Diskette, Fixed Disk, Removable Disks

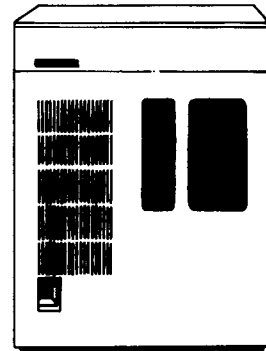

VS-50	VS	CPU, Diskette, Winchester Disk
VS-50A	VS	CPU, Diskette, Winchester Disk
VS-80	VS	CPU, Diskette

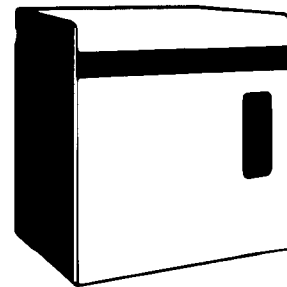

VS-90	VS	CPU, Diskette
VS-100	VS	CPU, Diskette

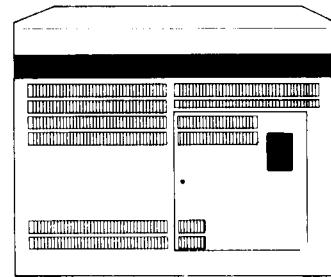
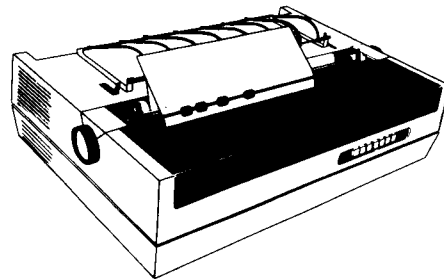
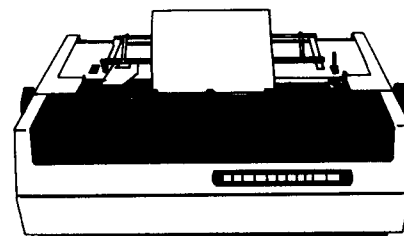

Table A-9. Printers/Plotters/Typesetters

Model	Product Line	Description
5541W	WP	35 cps Daisy Wheel Printer for WPS 5
6581W	WP/OIS	35 cps Daisy Wheel Printer for WPS 20, 25-3, 30 and all OIS Systems
6581W-1	ALLIANCE	35 cps Daisy Wheel Printer
2281W	2200	30 cps Daisy Printer/Plotter
2281WR	VS	30 cps Remote Parallel Daisy Printers for attachment to remote workstations only
6581W	VS	35 cps Daisy Output Printer for WP or DP usage
7581WT	WP/OIS	35 cps Daisy Printer
7581W-1T	ALLIANCE	35 cps Daisy Printer with 64K Memory



DW/5-20	WP	20 cps Bidirectional Daisy Wheel Printer for WPS 5
DW/WP-20	WP/OIS	20 cps Bidirectional Daisy Wheel Printer for WPS 20, 25-3, 30, and all OIS systems
DW/OS-20	OIS,VS ALLIANCE	20 cps Bidirectional Daisy Wheel Printer
DW/22-20	2200	20 cps Bidirectional Daisy Wheel Printer
DW/R-20	VS	20 cps Bidirectional Daisy Wheel Printer
5577	VS,WP/OIS ALLIANCE	192/40 cps High Density Matrix Printer



Model	Product Line	Description
5541WC	WP	35 cps Wide Carriage Daisy for WPS 5
6581WC	WP/OIS	35 cps Wide Carriage Daisy for WPS 20, 25-3, 30 and all OIS Systems
6581WC-1	ALLIANCE	35 cps Wide Carriage Daisy
2281WC	2200	30 cps Wide Carriage Daisy Printer/Plotter
2281WCR	VS	30 cps Remote Wide Carriage Parallel Daisy Printer for attachment to remote workstation only
6581WC	VS	35 cps Wide Carriage Daisy Printer for WP or DP usage
2281WR	VS	30 cps Remote Parallel Daisy Printer
5581WD	OIS	Twin-Head Extra Wide Carriage Daisy for all OIS systems
5581WD-1	ALLIANCE	Twin-Head Extra Wide Carriage Daisy
7581WCT	WP/OIS	35 cps Wide Carriage Daisy Printer
7581WC-1T	ALLIANCE	35 cps Wide Carriage Daisy Printer with 64K Memory

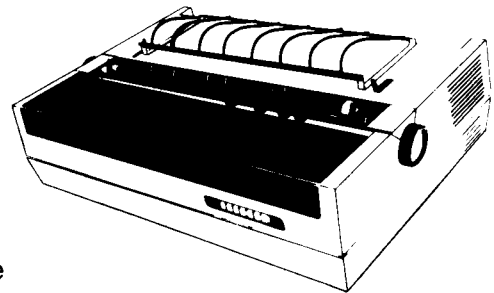

Model	Product Line	Description
5535	OIS	180 cps, 10-pitch Matrix Printer
5535-1	ALLIANCE	180 cps, 10-pitch Matrix Printer
5533	OIS	120 cps, 12.2-pitch Matrix Printer
5533-1	ALLIANCE	120 cps, 12.2-pitch Matrix Printer
2235	2200	181/222 cps 10/12.2-pitch Matrix Printer
2233	2200	100 cps, 10/12.2-pitch Matrix Printer
5535	VS	180 cps, 10-pitch Matrix Printer
5533	VS	120 cps, 12.2-pitch Matrix Printer
2233R	VS	100/120 cps, 10/12.2-pitch Bidirectional Remote Matrix Printer
2235R	VS	181/222 cps, 10/12.2-pitch Bidirectional Remote Matrix Printer

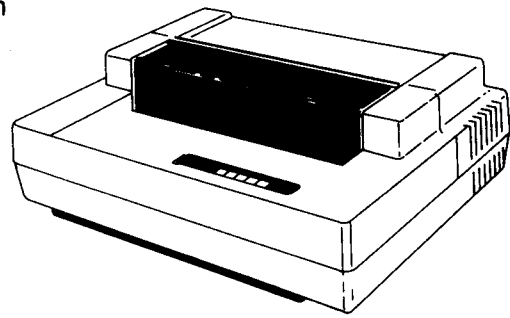

5574	OIS	Band Printer (600 lpm)
2273-1	2200	Band Printer (250 lpm)
2273-2	2200	Band Printer (600 lpm)
5573	VS	Band Printer (250 lpm)
5574	VS	Band Printer (600 lpm)
2273V-1	VS	Parallel Band Printer (250 lpm)

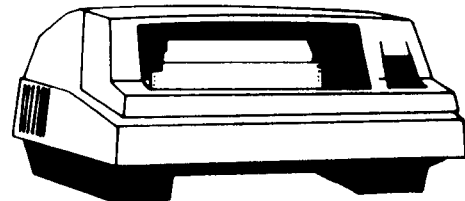

Model	Product Line	Description
5575	VS	850/1100 lpm, 96 character set

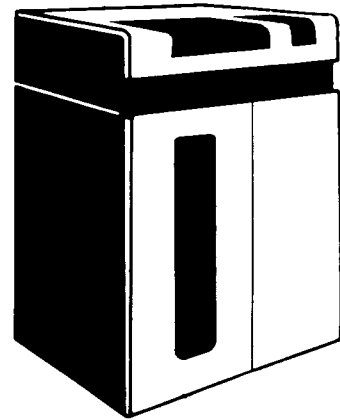

LPS-12	OIS,VS ALLIANCE	Laser Printer
--------	--------------------	---------------

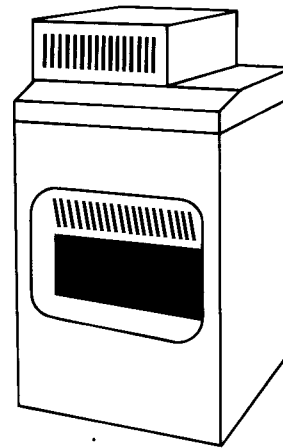

5548z	OIS,VS	Typesetter
48Z	OIS	Typesetter

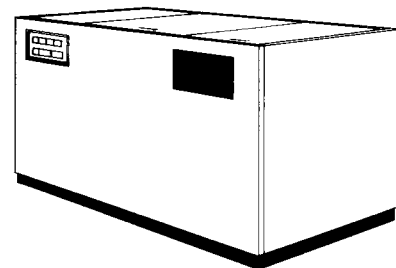

Model	Product Line	Description
2245	2200	80 cps Matrix Printer for screen dumps

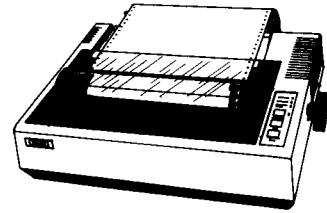

2231W-3	2200	Graphic Matrix Printer used with 2282 Graphic CRT
2231W-6	2200	High Density Matrix Printer

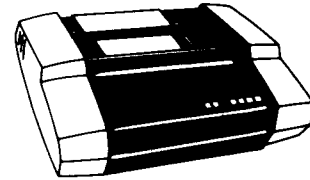

2282	2200	Graphic CRT only
------	------	------------------

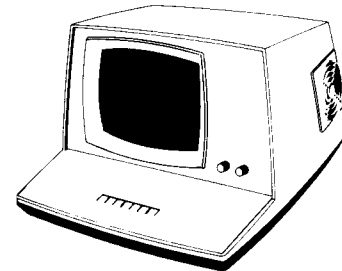
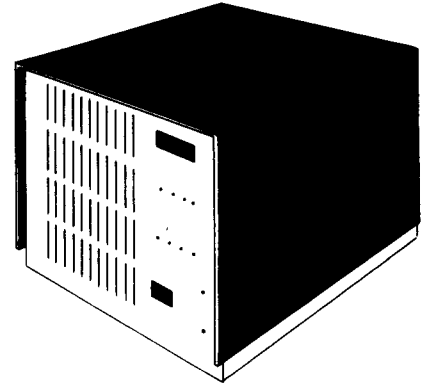
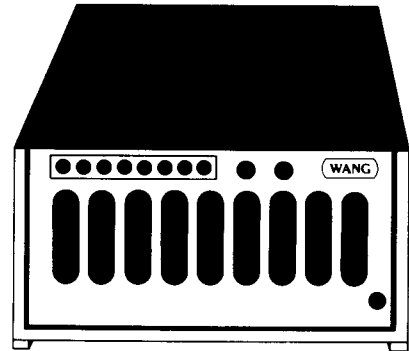

Table A-10. Miscellaneous Equipment

Model	Product Line	Description
6550-1	OIS	Wang Inter-System Exchange (WISE)



2247V-4	VS	4-Port Modem Sharing Unit (MSU) for Remote Workstation
---------	----	--



2244V	VS	Marked Sense/Punched Card Reader
-------	----	----------------------------------

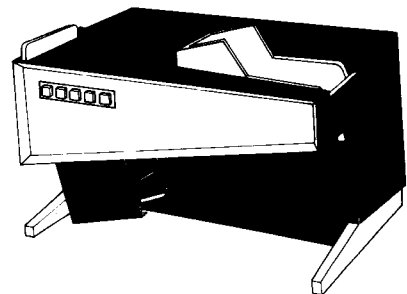

Model	Product Line	Description
2211M	2200	Printer Multiplexer (4 CPUs and 1 Printer)

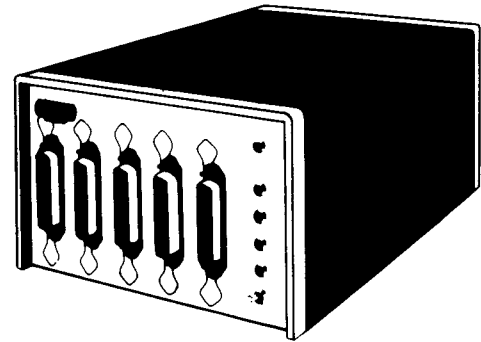

MCR-1 | WP/OIS | Magnetic Card Reader

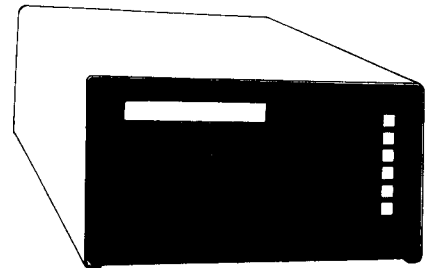

PIO-1 | WP/OIS | Paper Tape Interface
for Phototypesetting

PTP-2 | WP/OIS | Paper Tape Punch for
Telex, TWX

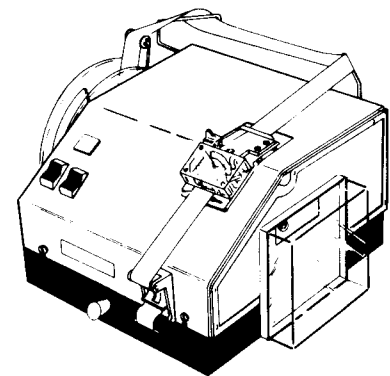
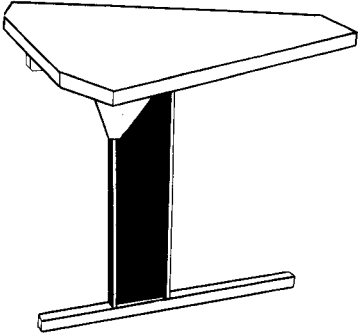
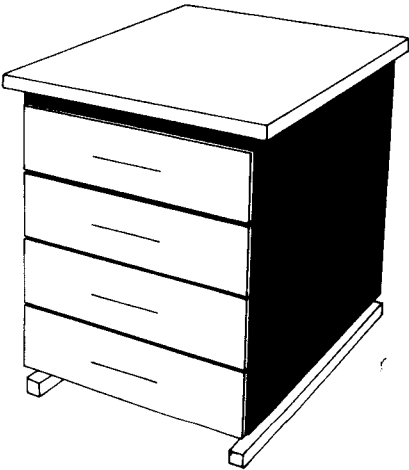

Table A-11. Standing Furniture

Model	Product Line	Description
CET-1	WP/OIS	Console Extension
8017-5	2200	Table Wedge



FST-1 | WP/OIS | File Supply Table



Model	Product Line	Description
MT-1*	WP/OIS	Table for System 20, 25 and 30 Master Workstations

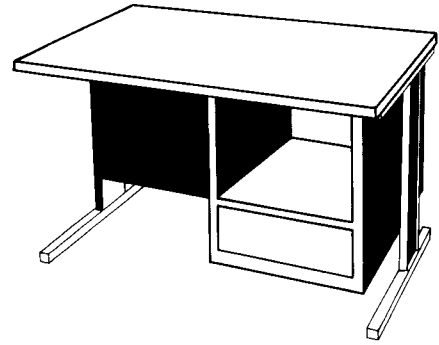

WST-1*	WP/OIS	Table for 5577, DW-20, 6581W and 6581WC Printer or Workstation
8009-5*	2200	CPU/Peripherals Table

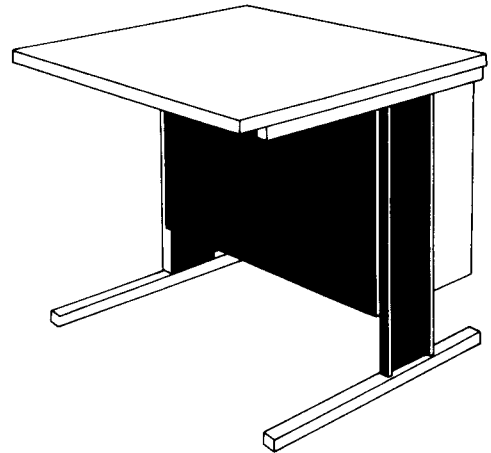

* The table provides 4 outlets collectively rated at 1400 watts and is fused for 10 A at 115 VAC or 5 A at 230 VAC.

Model	Product Line	Description
2297	WP/OIS	Disk Stand for WP 25-3 and WP 30 (Standard with OIS Disk Units)
2297	2200	Stand for 2260C Disk Drive

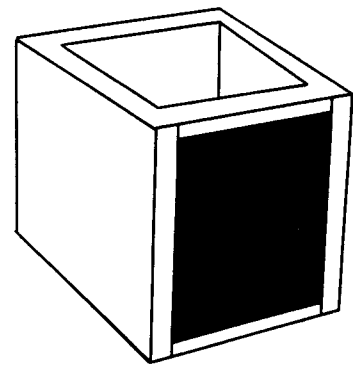

8005-5	WP/OIS	Stand for 5533 or 5535 Printer
8005-5	2200	Stand for 2233 or 2235 Printer

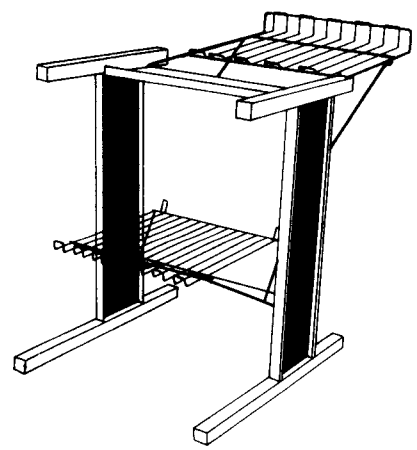

Model	Product Line	Description
8007-5*	2200	Table with CRT Cutout and Diskette Enclosure (left workspace)

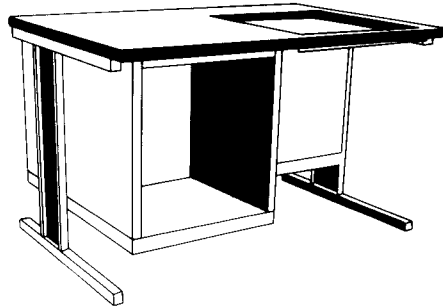

8002-5*	2200	Table with CRT Cutout and Diskette Enclosure (right workspace)
---------	------	--

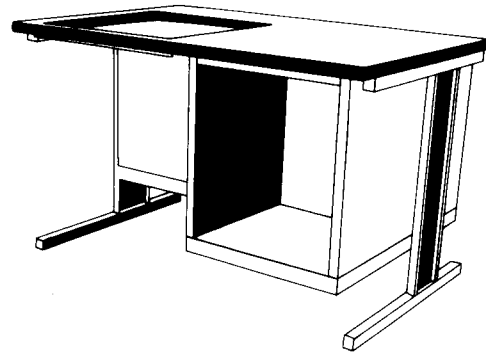

8001-5*	2200	Table with CRT Cutout
---------	------	-----------------------

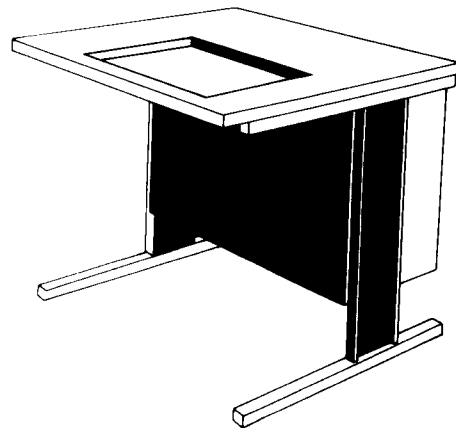

* The table provides 4 outlets collectively rated at 1400 watts and is fused for 10 A at 115 VAC or 5 A at 230 VAC.

APPENDIX B CABLES

The following tables list the length and part numbers of cables to be used with Wang system components. Refer to the *Wang Supplies Catalog (777-5725)* for prices of specific cables.

Table B-1. Cable Identification (2200 products)

Unit	Length (feet)	Identification	Part Number
2209A			
	10	Controller to tape drive (standard)	220-0168
2231W-3			
	12	Graphic CRT plotter to printer/matrix plotter (standard)	220-0105-1
2236DE, 2236DW 2336DW			
	25	Controller to workstation	120-2236-25
	50	Controller to workstation	120-2236-50
	100	Controller to workstation	120-2236-1
	200	Controller to workstation	120-2236-2
	300	Controller to workstation	120-2236-3
	400	Controller to workstation	120-2236-4
	500	Controller to workstation	120-2236-5
	600	Controller to workstation	120-2236-6
	700	Controller to workstation	120-2236-7
	800	Controller to workstation	120-2236-8
	900	Controller to workstation	120-2236-9
	1,000	Controller to workstation	120-2236-10
	1,250	Controller to workstation	120-2236-11
	1,500	Controller to workstation	120-2236-12
	1,750	Controller to workstation	120-2236-13
	2,000	Controller to workstation	120-2236-14
	12	Modem to workstation (standard)	120-0113
	25	Modem to workstation (standard)	120-0219
	50	Modem to workstation (standard)	120-0220
	25	Modem to workstation extension	120-2227-25
	50	Modem to workstation extension	120-2227-50

Table B-1. Cable Identification (2200 products) (continued)

Unit	Length (feet)	Identification	Part Number
2260B			
	13	Controller to disk (standard)	220-0066
2260B-2			
	5	Disk to disk	220-0151
2260C			
	10	Controller to disk (standard)	220-0188
2260C-2			
	10	Controller to disk (standard)	220-0169
	5	Disk to disk	220-0187
2270A-1, A-2, A-3			
	13	Controller to IBM-compatible disk (standard)	220-0066-4
2273-1,2			
	12	Controller to printer (standard)	220-0105
	25	Controller to printer	120-2225-25
	50	Controller to printer	120-2225-50
2280-1,-2,-3			
	5	"A" cable from microprocessor to disk (std.)	220-2033
	5	"B" cable from microprocessor to disk (std.)	220-3033-5
2280DPU			
	12	Controller to microprocessor (standard)	220-0138
2281W, 2281WC			
	12	Controller to printer/plotter (standard)	220-0161

Table B-1. Cable Identification (2200 products) (continued)

Unit	Length (feet)	Identification	Part Number
2282			
	12	Controller to graphic CRT plotter (standard)	220-0105-2
177-2227			
	12	Controller to modem (interface cable)	220-0113
	25	Controller to modem (interface cable)	220-0219
	50	Controller to modem (interface cable)	220-0220
	25	Controller to modem (extensions)	120-2227-25
	50	Controller to modem (extensions)	120-2228-50
177-2228			
	12	Controller to modem (interface cable)	220-0113
	25	Controller to modem (interface cable)	220-0219
	50	Controller to modem (interface cable)	220-0220
	25	Controller to modem (extensions)	120-2227-25
	50	Controller to modem (extensions)	120-2228-50

Table B-2. Cable Identification (WPS/OIS products)

Unit	Length (feet)	Identification	Part Number
WPS 5			
	8	Master to workstation - keyboard (supplied)	220-0105-3
	8	Master to workstation - coax (supplied)	220-0199
	25	Extension cable*	
	50	Extension cable*	
	25	Coaxial cable*	220-0139
	50	Coaxial cable*	120-2292-50
	12	Master to printer (supplied)	220-0198
	25	Extension cable	120-2114-25
	50	Extension cable	120-2115-50
WPS 20, 25, 30, all OIS			
	25	Master to workstation cables (supplied)**	220-0148
	25	Master to printer cables (supplied)**	220-0148
Refer to Table B-4 for peripheral cables.			
WPS 25, 30, OIS 105, 115, 130A, 140, 145			
	6	Master to disk (supplied)	220-0108-3
OIS 145 – 275 Mb type drive			
	10	Control cable to master (supplied)	220-3031-1
	15	Control cable to master	220-3041-6
	15	Data cable to master (supplied)	220-3033-18
	24	Data cable to master	220-3033-19
OIS 145 – 10 Mb type drive			
	12	First disk to master (supplied)	220-0169
	6	Second disk to first disk (supplied)	220-0287
* Customers wishing to increase master-to-workstation cable length must order both the extension cable and the coaxial cable.			
** Printers for WPS and OIS are supplied with 25-foot coaxial cables, but longer lengths up to 2,000 feet may be ordered. Refer to Table B-4 for sizes and part numbers.			

Table B-3. Cable Identification (VS products)

Unit	Length (feet)	Identification	Part Number
2280V-1,2,3			
	15	"A" cable from VS 80	220-3041-6
	25	"A" cable from VS 80	220-3041-14
	50	"A" cable from VS 80	220-3041-15
	15	"B" cable to VS 80	220-3033-18
	25	"B" cable to VS 80	220-3033-19
	50	"B" cable to VS 80	220-3033-30
	15	"A" cable from VS 45/90/100	220-3041-7
	25	"A" cable from VS 45/90/100	220-3041-20
	50	"A" cable from VS 45/90/100	220-3041-21
	15	"B" cable to VS 45/90/100	220-3033-21
	25	"B" cable to VS 45/90/100	220-3033-22
	50	"B" cable to VS 45/90/100	220-3033-33
	10	"A" cable, 2280 V's to 2280 V's	220-3031-1
	10	"A" cable, 2280 V's to 2265 V-2's	220-3031-5
	10	"A" cable, 2280 V's to 2265 V-1	220-3031-6
2265V-1			
	15	"A" cable from VS 80	220-3041-3
	25	"A" cable from VS 80	220-3041-10
	50	"A" cable from VS 80	220-3041-11
	15	"B" cable to VS 80	220-3033-12
	25	"B" cable to VS 80	220-3033-13
	50	"B" cable to VS 80	220-3033-32
	15	"A" cable from VS 45/90/100	220-3041-9
	25	"A" cable from VS 45/90/100	220-3041-16
	50	"A" cable from VS 45/90/100	220-3041-17
	15	"B" cable to VS 45/90/100	220-3033-25
	25	"B" cable to VS 45/90/100	220-3033-26
	50	"B" cable to VS 45/90/100	220-3033-35
	10	"A" cable, 2265V-1 to 2265V-1	220-3031-3
	10	"A" cable, 2265V-1 to 2265V-2's	220-3031-4
2265V-2A, 2A1			
	15	"A" cable from VS 80	220-3041-4
	25	"A" cable from VS 80	220-3041-12
	50	"A" cable from VS 80	220-3041-13
	10	"A" cable, 2265V-2's to 2265V-2's	220-3031-2

Table B-3. Cable Identification (VS products) (continued)

Unit	Length (feet)	Identification	Part Number
2265V-2A, 2A1,2B			
	15	"B" cable to VS 80	220-3033-14
	25	"B" cable to VS 80	220-3033-15
	50	"B" cable to VS 80	220-3033-31
2265V-2A, 2A1			
	15	"A" cable from VS 45/90/100	220-3041-8
	25	"A" cable from VS 45/90/100	220-3041-18
	50	"A" cable from VS 45/90/100	220-3041-19
2265V-2A, 2A1,2B			
	15	"B" cable to VS 45/90/100	220-3033-23
	25	"B" cable to VS 45/90/100	220-3033-24
	50	"B" cable to VS 45/90/100	220-3033-34

Table B-4. Coaxial Cables

Length	Part Number
50	120-2300-1
100	120-2300-2
150	120-2300-3
200	120-2300-4
250	120-2300-5
300	120-2300-6
350	120-2300-7
400	120-2300-8
450	120-2300-9
500	120-2300-10
550	120-2300-11
600	120-2300-12
650	120-2300-13
700	120-2300-14
750	120-2300-15
800	120-2300-16
850	120-2300-17
900	120-2300-18
950	120-2300-19
1,000	120-2300-20
1,050	120-2300-21
1,100	120-2300-22
1,150	120-2300-23
1,200	120-2300-24
1,250	120-2300-25
1,300	120-2300-26
1,350	120-2300-27
1,400	120-2300-28
1,450	120-2300-29
1,500	120-2300-30
1,550	120-2300-31
1,600	120-2300-32
1,650	120-2300-33
1,700	120-2300-34
1,750	120-2300-35
1,800	120-2300-36
1,850	120-2300-37
1,900	120-2300-38
1,950	120-2300-39
2,000	120-2300-40
TNC (Bullet) Adapter	350-2076
BNC (Bullet) Adapter	350-2077

APPENDIX C SITE LAYOUT GRIDS

The following pages consist of a grid layout of a floor plan (Figure C-1) and a grid layout for equipment floor space dimensions (Figure C-2). To arrange the best possible placement of your system, first map out the area of your equipment room in Figure C-1. Each small square in Figure C-1 represents 2 in. (5.08 cm); each block of six squares represents 1 ft (.3048 m). Next, by referring to the recommended floor space of equipment in Tables A-1 through A-4, cut out the floor space dimensions of your equipment from Figure C-2 and place them on Figure E-1. (Label the cutouts as necessary.) Rearrange the floor space cutouts until you arrive at a suitable set up for your equipment. Reserve enough room for office furniture, supplies, and other necessities.

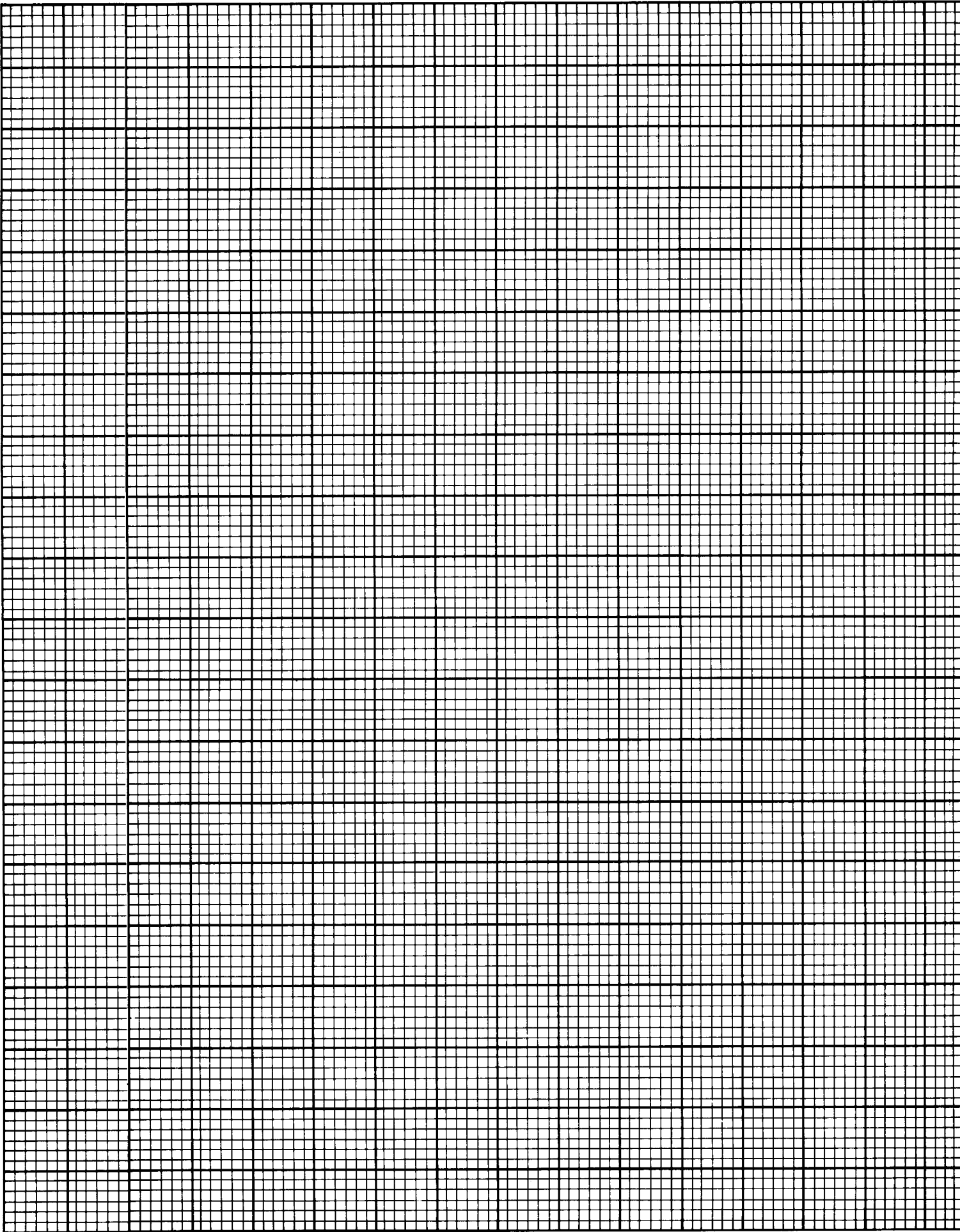
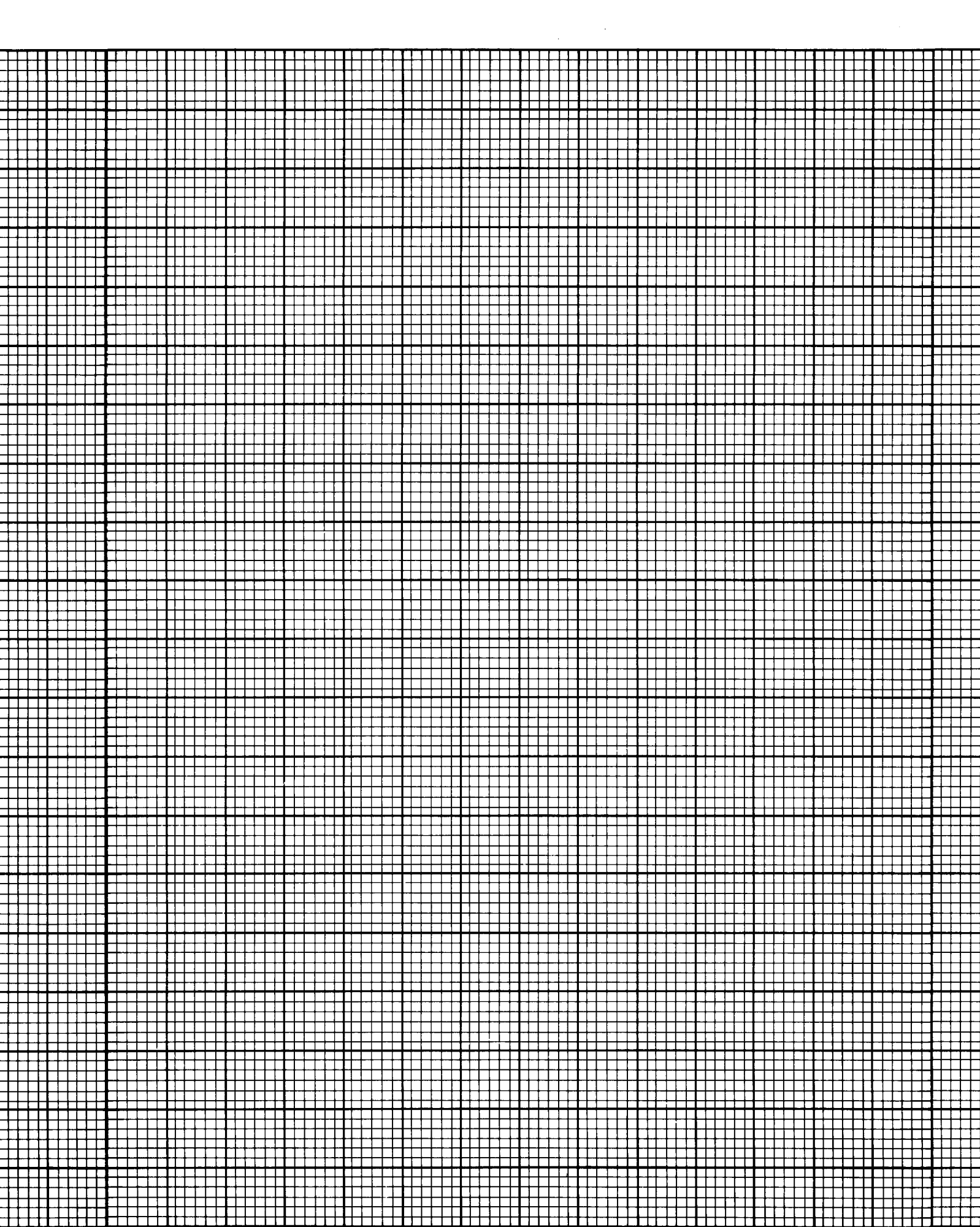

Figure C-1. Floor Plan Layout Grid



6 squares to one foot (.3m)

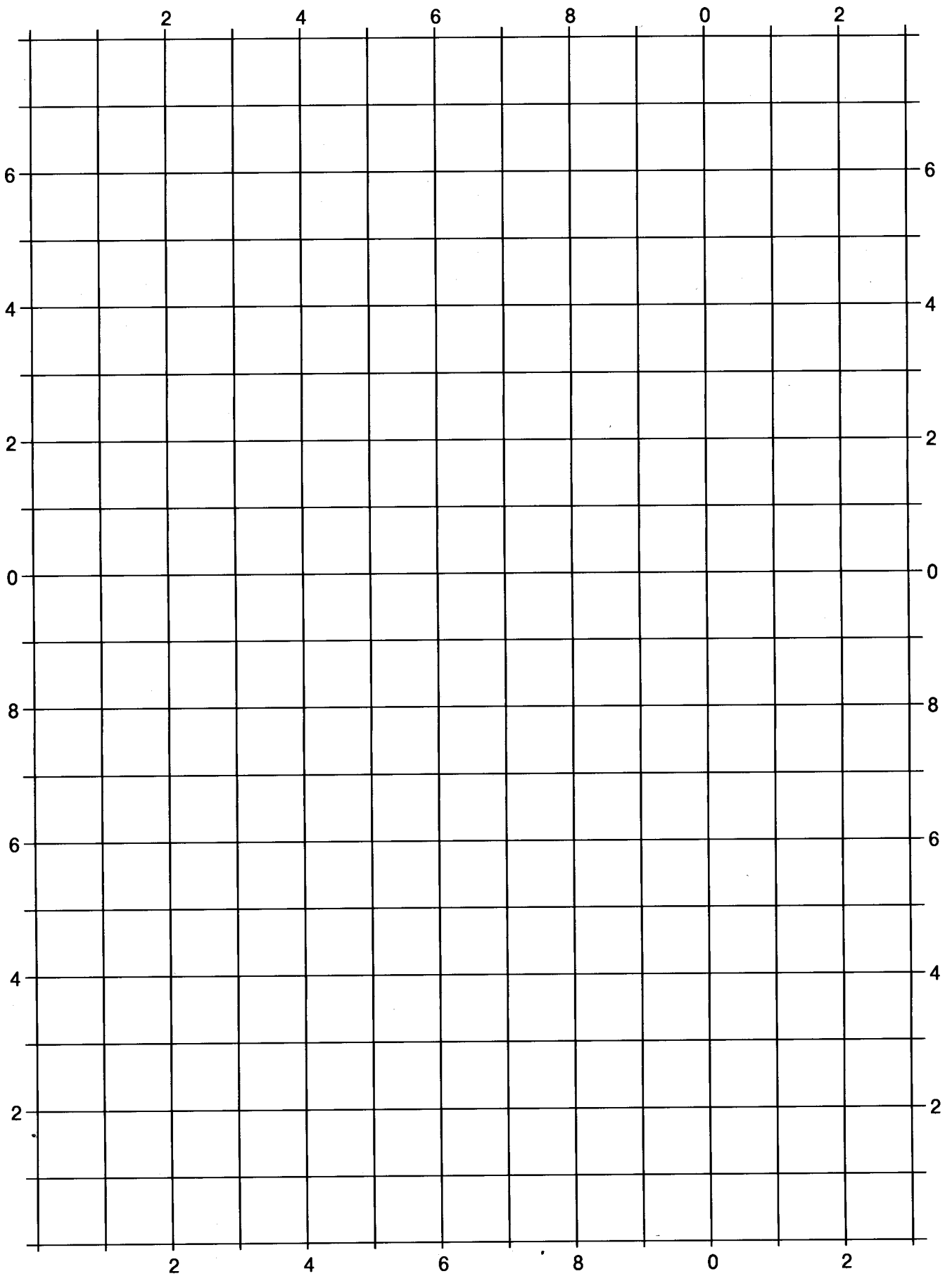

Figure C-2. Recommended Equipment Floor Space Cutouts

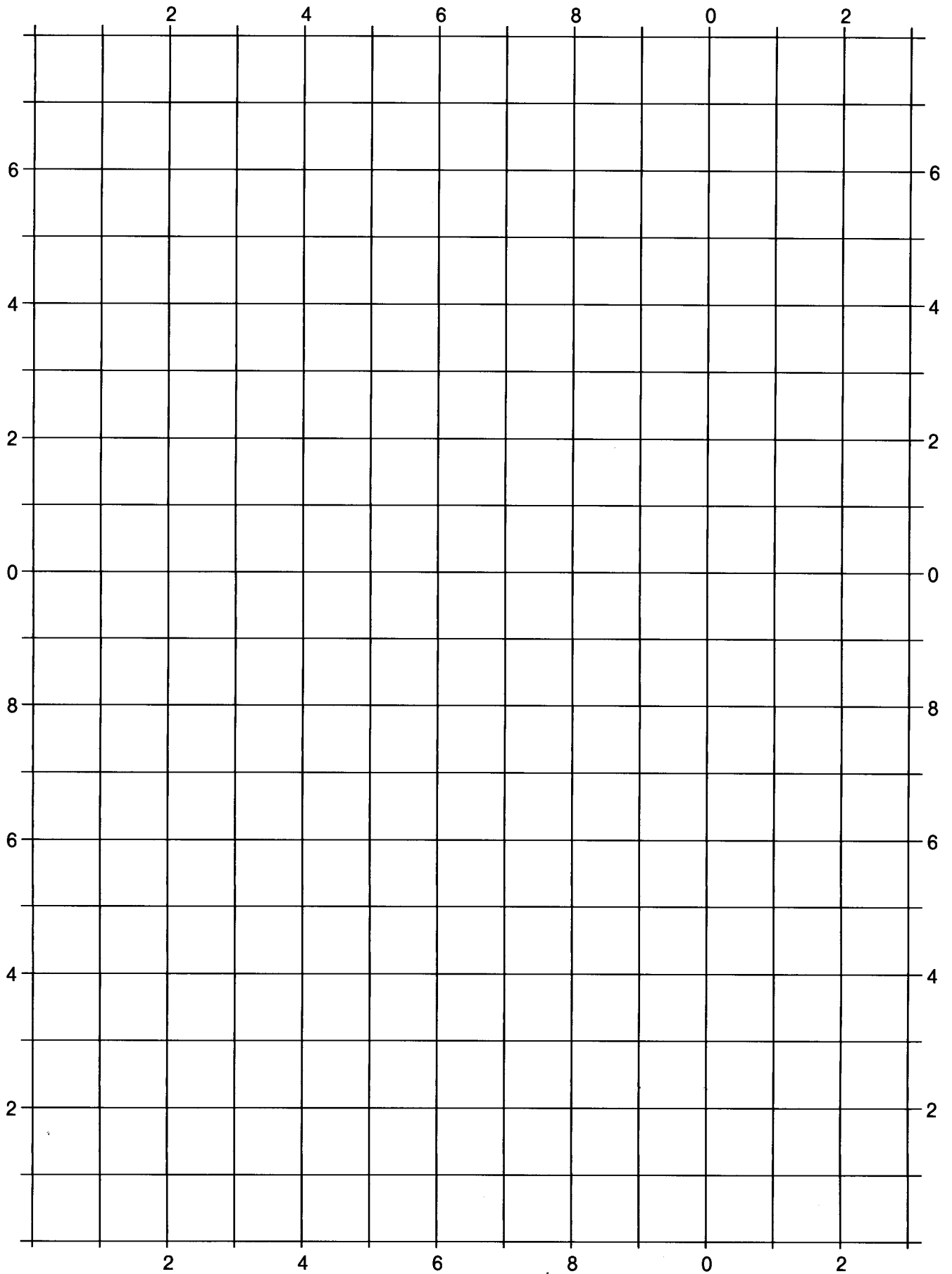

Figure C-2. Recommended Equipment Floor Space Cutouts (continued)

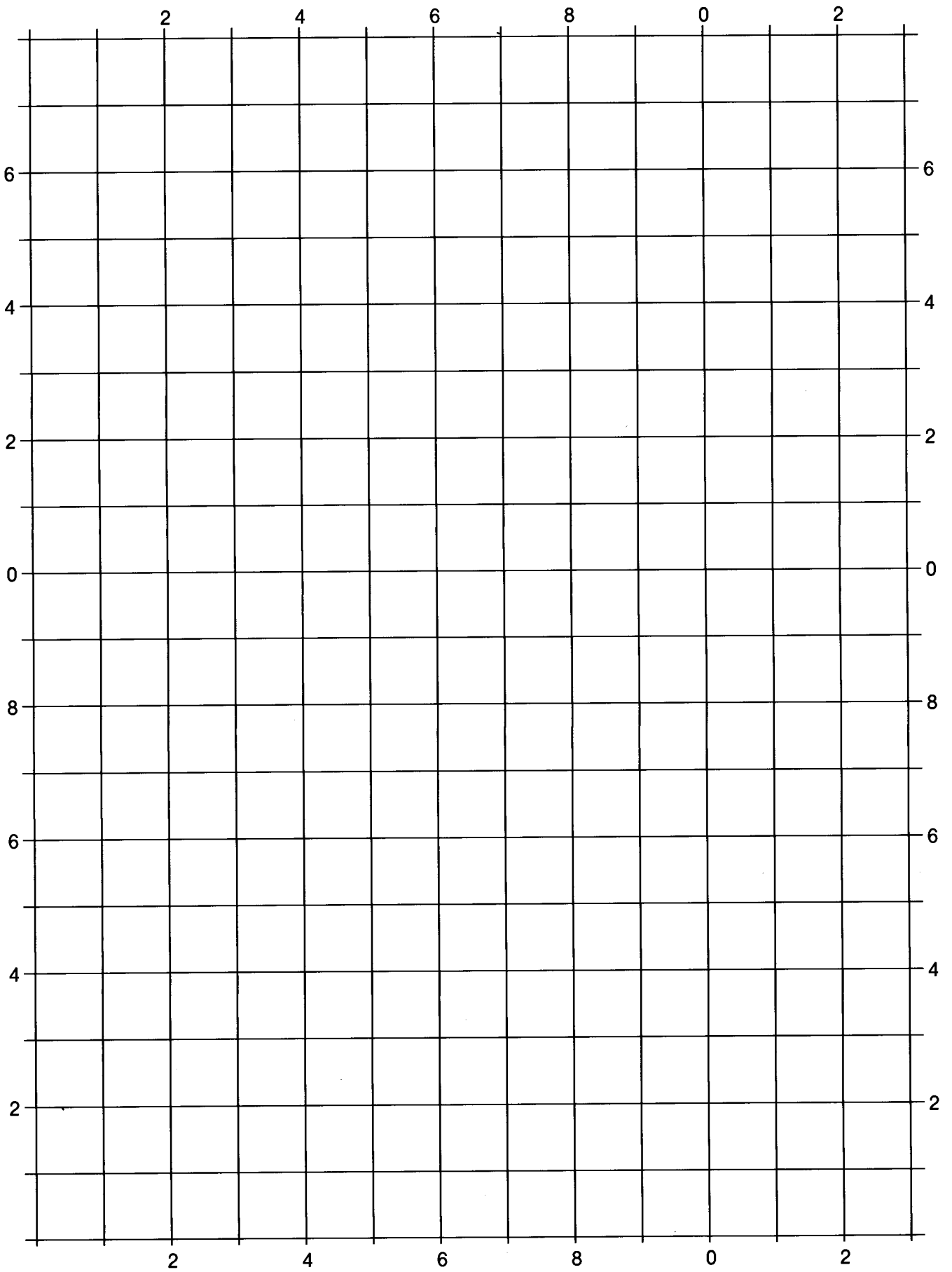

Figure C-2. Recommended Equipment Floor Space Cutouts (continued)

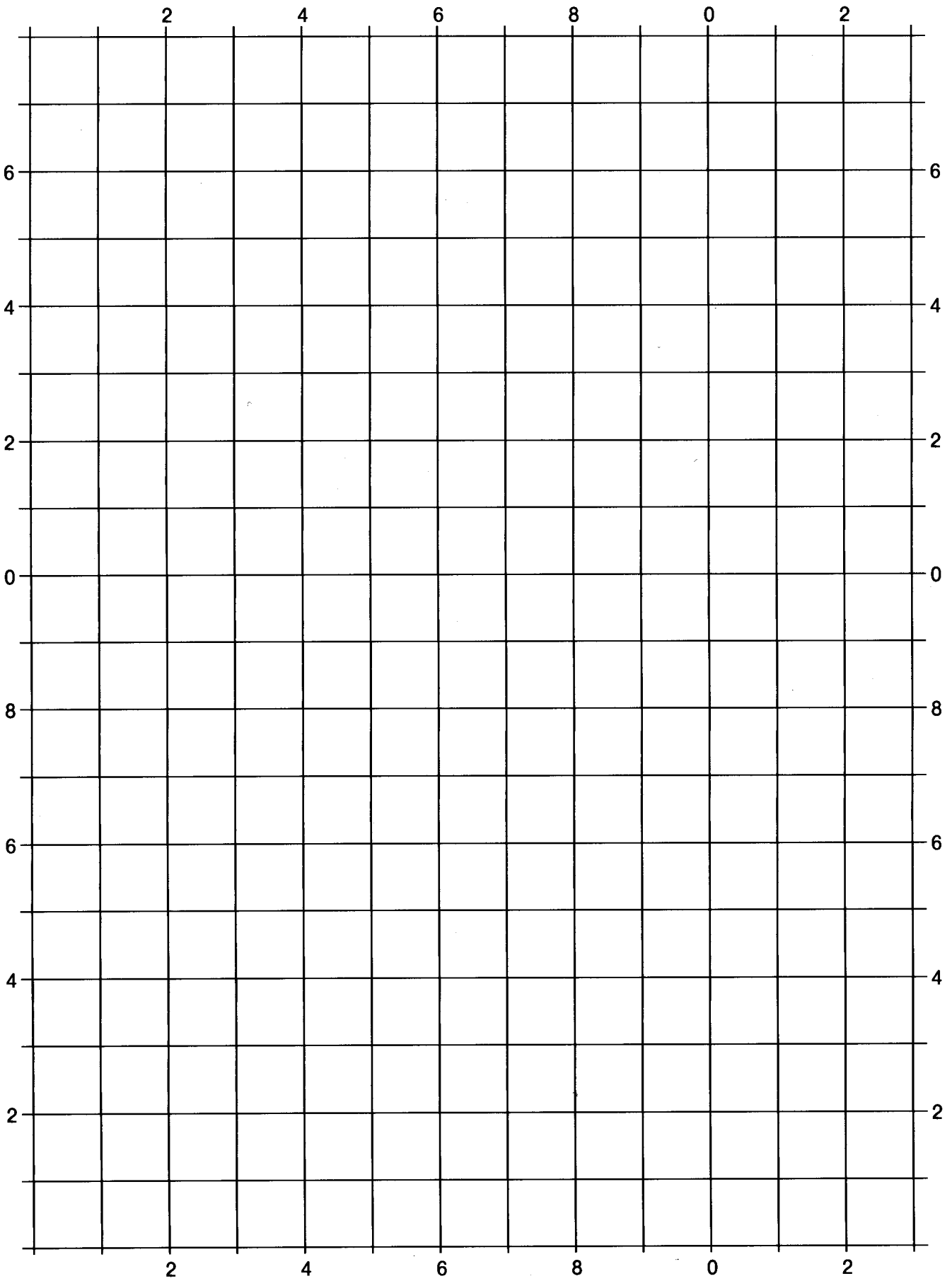

Figure C-2. Recommended Equipment Floor Space Cutouts (continued)

APPENDIX D VS-90 AND VS-100 MAINFRAME ELECTRICAL CONSIDERATIONS

D.1 PRIMARY AC POWER WIRING

The recommended method of installing primary AC power wiring to a VS-90 or VS-100 System mainframe is as shown in Figure D-1.

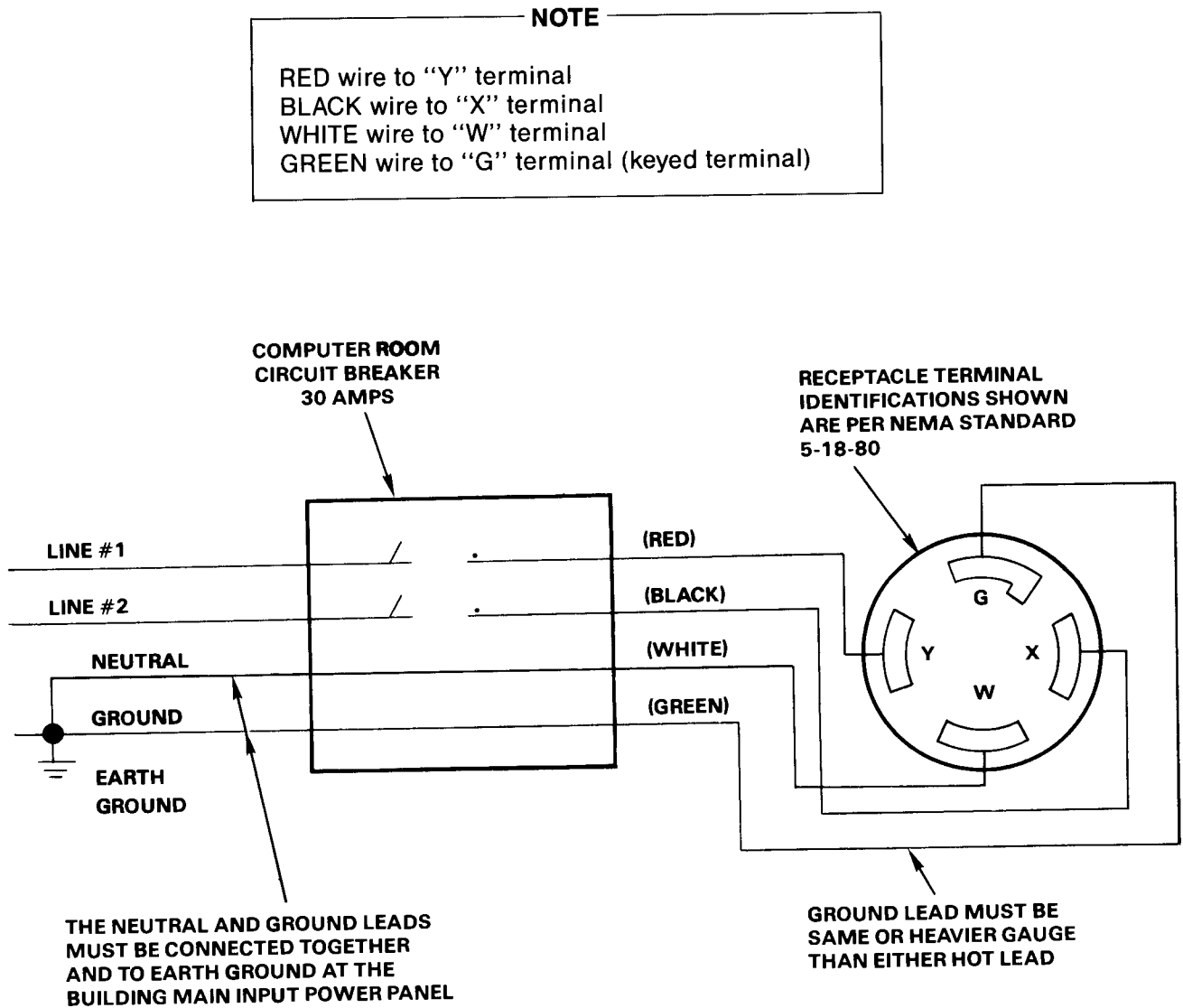

Figure D-1. Recommended AC Wiring Schematic for the VS-90 and VS-100

D.2 AC VOLTAGE CHECKOUT

After installation, the AC primary power wiring should be checked by performing the following voltage measurements.

From	To	Voltage
Y	X	230/208 VAC, +10%, -10%
Y	G	115/110 VAC, +10%, -10%
Y	W	115/110 VAC, +10%, -10%
X	G	115/110 VAC, +10%, -10%
X	W	115/110 VAC, +10%, -10%
W	G	0 VAC

D.3 INPUT AC POWER VARIATION HANDLING CAPABILITY

The line filters currently installed in the VS Power Box can effectively handle the following:

- Transients up to 10 joules
- Peak currents of 1,000 amps for pulse durations of less than 20 microseconds, and frequencies from 1 Hz to 10 MHz
- Voltage amplitudes of 190V peak

APPENDIX E INSTALLATION CONSIDERATIONS FOR 7500T EQUIPMENT

E.1 INTRODUCTION

There are several factors to consider when preparing a site for installation of 7500T products. It is important to ensure:

- the safe operation of the system by the user;
- that system operation is not interrupted;
- that the security issues inherent to 7500T products are not compromised.

E.2 ELECTRICAL

Wang Laboratories, Inc., manufactures all 7500T products with a third-wire electrical ground. This feature provides a safe electrical ground for the entire system. By not using the third-wire ground, users are exposed to a possible electrical shock that may also jeopardize overall system operation. When installing the electrical circuits for 7500T products, the customer should allow for a third-wire ground.

Wang Laboratories, Inc., *strongly* recommends the installation and use of dedicated power lines. Dedicated power to a 7500T system installation is provided by a dedicated line from the distribution point to a CPU and its associated disk drive(s). The line is not shared by any non-Wang equipment. The distribution point for the dedicated power source is determined by the customer. The optimal dedicated power configuration is one dedicated line per unit; however, the system approach is acceptable provided that nominal CBEMA voltage specifications (sags, surges and voltage stability) are maintained at each socket to eliminate any unit interaction.

E.3 PHYSICAL SECURITY

Wang Laboratories is not responsible for the site planning or installation of those physical security devices or measures required for the local operation of 7500T systems. It is the responsibility of the customer to consult his respective security regulations and review individual operating procedures and requirements with local security officials.

E.4 CABLING

Through a rigorous inspection and quality control program, Wang Laboratories, Inc., warrants and insures that Wang cables are suitable for use with 7500T products. When installing 7500T products, Wang Laboratories, Inc., will only honor Wang-provided cable, cable connectors, and cable adaptors.

The use of non-Wang cable and cable accessories may compromise the overall integrity of 7500T systems. The Wang Supplies Division is the only approved source of cables, connectors, and adaptors for 7500T equipment. Wang cannot assume responsibility for the quality or effect on 7500T systems of cables or cable accessories purchased through any other source. Refer to the *Wang Supplies Catalog* (777-5725) and Table 3-4 for further details on maximum allowable cable lengths and 7500T cable products.

Wang Laboratories, Inc., is responsible for the installation of cable connectors only and will warrant the integrity of those installed. However, Wang does not provide for installation of cables, conduiting, cable trays, or any other aspect of cable installation. The customer should consult with the proper local security officials and regulations to ensure that the cable installation meets the specification outlined in MIL-232.

E.5 MISCELLANEOUS

The customer should be aware that 7500T products cannot be interfaced with non-7500T products. Furthermore, not all 7500T products are compatible with Wang-manufactured furniture.



Title _____ CUSTOMER SITE PLANNING GUIDE

Help Us Help You . . .

We've worked hard to make this document useful, readable, and technically accurate. Did we succeed? Only you can tell us! Your comments and suggestions will help us improve our technical communications. Please take a few minutes to let us know how you feel.

How did you receive this publication?

- Support or Sales Rep, Wang Supplies Division, From another user, Enclosed with equipment, Don't know, Other

How did you use this Publication?

- Introduction to the subject, Classroom text (student/teacher), Self-study text, Aid to advanced knowledge, Guide to operating instructions, As a reference manual, Other

Please rate the quality of this publication in each of the following areas.

Table with 5 columns: EXCELLENT, GOOD, FAIR, POOR, VERY POOR. Rows include Technical Accuracy, Readability, Clarity, Examples, Organization, Illustrations, Physical Attractiveness.

Were there any terms or concepts that were not defined properly? Y N If so, what were they?

After reading this document do you feel that you will be able to operate the equipment/software? Yes No Yes, with practice

What errors or faults did you find in the manual? (Please include page numbers)

Do you have any other comments or suggestions?

Name _____ Street _____

Title _____ City _____

Dept/Mail Stop _____ State/Country _____

Company _____ Zip Code _____ Telephone _____

Thank you for your help.



Fold



NO POSTAGE
NECESSARY
IF MAILED
IN THE
UNITED STATES

BUSINESS REPLY CARD
FIRST CLASS PERMIT NO. 16 LOWELL, MA

POSTAGE WILL BE PAID BY ADDRESSEE

**WANG LABORATORIES, INC.
CHARLES T. PEERS, JR., MAIL STOP 1363
ONE INDUSTRIAL AVENUE
LOWELL, MASSACHUSETTS 01851**

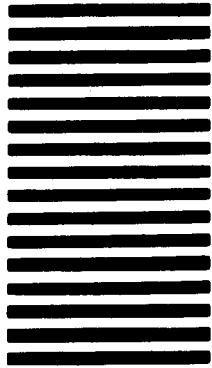

Cut along dotted line.

Fold

WANG

The completed order form should be mailed to:

WANG LABORATORIES, INC.
 Supplies Division
 51 Middlesex St.
 No. Chelmsford MA 01863

To Order by Phone, Call:

(800)225-0234

From Mass., Hawaii, and Alaska

(617)256-1400**TELEX 951-743**

Order Form for Wang Manuals and Documentation

① Customer Number (If Known) _____				
② Bill To: _____			Ship To: _____	
_____			_____	
_____			_____	
_____			_____	
③ Customer Contact: _____		④ Date _____	Purchase Order Number _____	
() () _____		_____		
Phone _____		Name _____		
⑤ Taxable Yes <input type="checkbox"/> No <input type="checkbox"/>	⑥ Tax Exempt Number _____	⑦ Credit This Order to _____		
		A Wang Salesperson _____		
		Please Complete Salesperson's Name _____ Employee No. _____ RDB No. _____		
⑧ Document Number	Description	Quantity	⑨ Unit Price	Total Price
⑩ _____ Authorized Signature _____ Date _____ <input type="checkbox"/> Check this box if you would like a free copy of the Corporate Publications Literature Catalog (700-5294)			Sub Total	
			Less Any Applicable Discount	
			Sub Total	
			Local/State Tax	
			Total Amount	

Ordering Instructions

- If you have purchased supplies from Wang before, and know your Customer Number, please write it here.
- Provide appropriate Billing Address and Shipping Address.
- Please provide a phone number and name, should it be necessary for WANG to contact you about your order.
- Your purchase order number and date.
- Show whether order is taxable or not.
- If tax exempt, please provide your exemption number.
- If you wish credit for this order to be given to a WANG salesperson, please complete.
- Show part numbers, description and quantity for each product ordered.
- Pricing extensions and totaling can be completed at your option; Wang will refigure these prices and add freight on your invoice.*
- Signature of authorized buyer and date.

Wang Supplies Division Terms and Conditions

- TAXES** — Prices are exclusive of all sales, use, and like taxes.
- DELIVERY** — Delivery will be F.O.B. Wang's plant. Customer will be billed for freight charges; and unless customer specifies otherwise, all shipments will go best way surface as determined by Wang. Wang shall not assume any liability in connection with the shipment nor shall the carrier be construed to be an agent of Wang. If the customer requests that Wang arrange for insurance the customer will be billed for the insurance charges.
- PAYMENT** — Terms are net 30 days from date of invoice. Unless otherwise stated by customer, partial shipments will generate partial invoices.
- PRICES** — The prices shown are subject to change without notice. Individual document prices may be found in the Corporate Publications Literature Catalog (700-5294)
- LIMITATION OF LIABILITY** — In no event shall Wang be liable for loss of data or for special, incidental or consequential damages in connection with or arising out of the use of or information contained in any manuals or documentation furnished hereunder.



Fold



NO POSTAGE
NECESSARY
IF MAILED
IN THE
UNITED STATES

BUSINESS REPLY CARD
FIRST CLASS PERMIT NO. 16 NO. CHELMSFORD, MA.

POSTAGE WILL BE PAID BY ADDRESSEE

WANG LABORATORIES, INC.
Supplies Division
c/o Order Entry Dept.
M/S 5511
51 Middlesex St.
No. Chelmsford, MA 01863

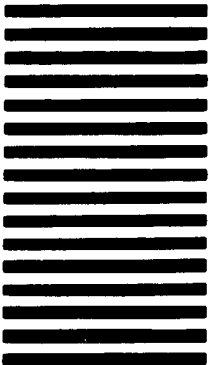

Fold



WANG LABORATORIES, INC., ONE INDUSTRIAL AVENUE, LOWELL, MA 01851 • TEL. (617) 459-5000, TWX 710-343-6769, Telex 94-7421

Printed in U.S.A.
700-5978D
11-83-25M